

T-3<sup>1/4</sup> bayonet (MCC) lamp

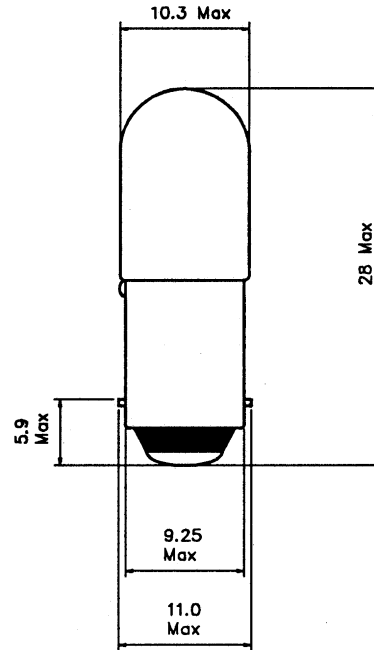

Drawing Not To Scale - All Dimensions in mm.

Type	Size	Rating	Category	Description	Part No.
Incandescent	T10x28	5V 90mA		T-3 <sup>1/4</sup> bayonet (MCC)lamp	W440

**PHOTOMETRY DATA**

Test Volts	Current (mA)			Light output (Lm)			Life (Hours)
	Min.	Nom.	Max.	Min.	Nom.	Max.	
5.0	81	90	99	2.85	3.1	3.9	750

**NOTES**

1. Lamp base BA9s/13 in accordance with IEC61-1, (BS EN 60061-1), sheet 7004-14-x.
2. C-2R filament shape.
3. Light Centre Length: 16,0±1mm
4. Lamp shall withstand a cap torsion of 0,3Nm. (2,56lbf.inches)
5. Marking: "5V 90mA" with "SLI" or "VCH" trademark, to be engraved or durably ink-stamped on the cap.

