

# PCB Mounting Clip

## MC55i

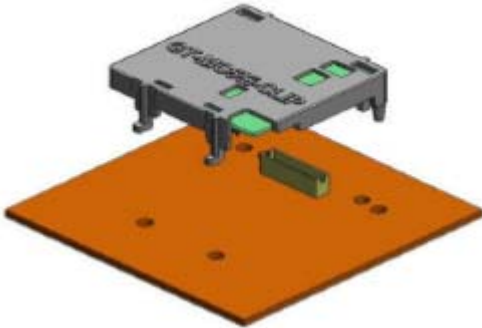

### Feature:

- PCB mounting clip design for Cinterion wireless module.

### Specifications:

#### Board to Board Connector Information:

Cinterion module board side header	: Hirose DF12C (3.0) - 50DS - 0.5V (86).
PCB mating board side receptable	: Hirose DF12E (5.0) - 50DP - 0.5V (86).
Size	: 50 pins.
Stacking height	: 5.0mm.
PCB mating board thickness	: 1.6mm.
Pulling force (module clip on PCB)	: Minimum 10N Maximum 150N.

#### Clip Specifications:

##### Physical:

Clip material	: PC-940A.
Clip colour	: Black.
RoHS compliant.	
Operating temperature	: -40°C to +100°C.

### Assembled Dimensions

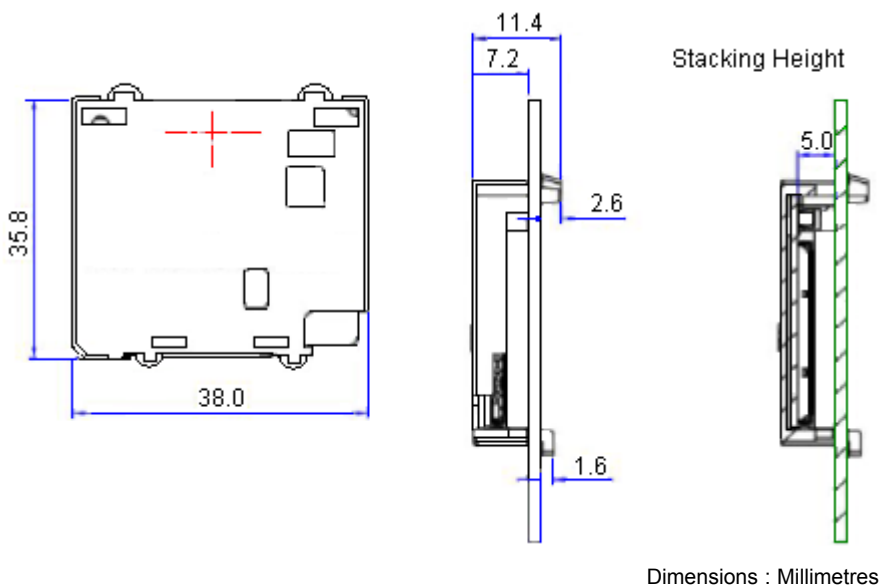

# PCB Mounting Clip MC55i



## Module Clip PCB Footprint and Connector Receptacle Dimensions:

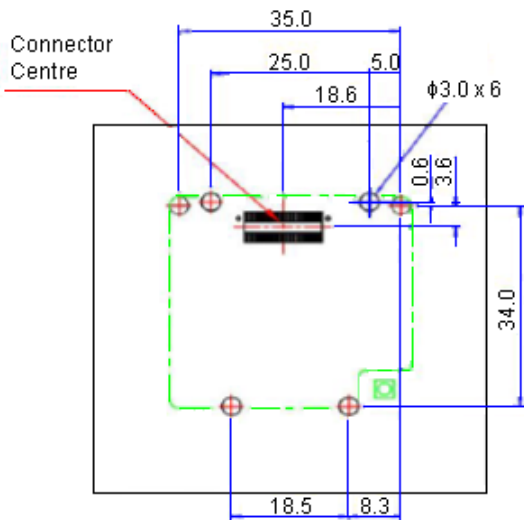

Module Clip PCB Footprint

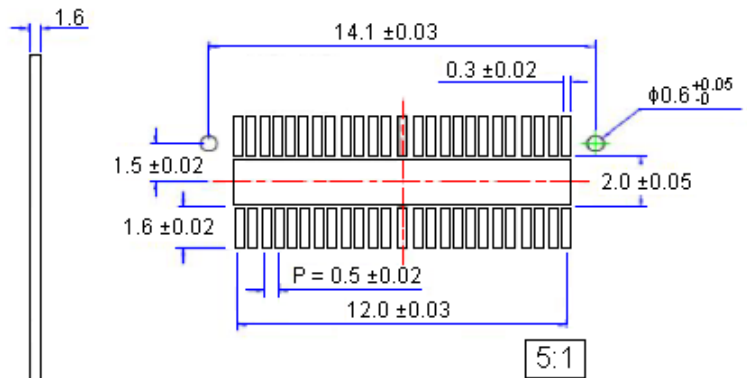

PCB Connector Receptacle Dimensions

Dimensions : Millimetres

## Mounting Clip for Cinterion:

### Mounting Instructions (Module into Clip):

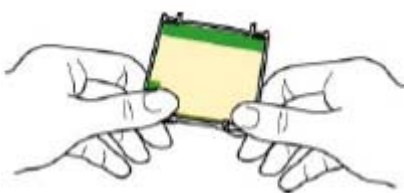
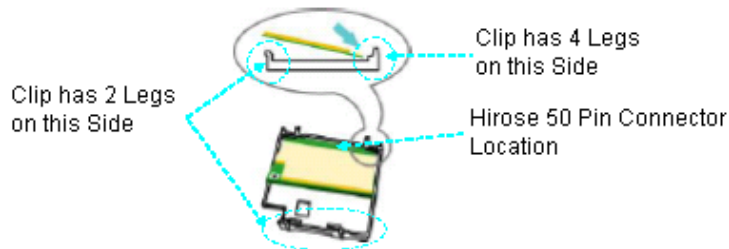

#### 1st Step:

Orientate the module in the clip: the side with a Hirose 50 pin connector is the side which goes into the clip first. Insert the module at an inclined angle, sliding the edge of the PCB underneath the two retaining lugs of the clip.

#### 2nd Step:

Press the other side of the module vertically downwards to fit it into the clip.

# PCB Mounting Clip

## MC55i



### Mounting Instructions (Module + Clip into Circuit Board):

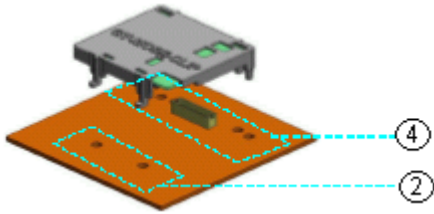

#### 1<sup>st</sup> Step:

Orientate the clip legs with the PCB mounting holes with 'GT-MC55i-CLIP' characters upright.

- ④ 4 holes at the top, near the Hirose receptacle.
- ② 2 holes at the bottom.

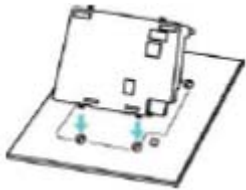

#### 2<sup>nd</sup> Step:

Insert the 2 legs of the clip first, into the corresponding holes on the PCB footprint . Be sure to completely insert the 2 legs before beginning the 3<sup>rd</sup> step.

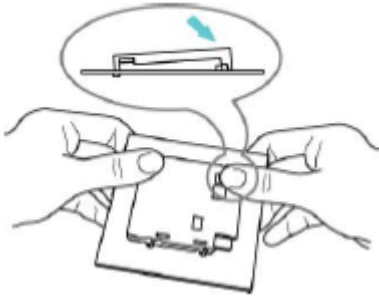

#### 3<sup>rd</sup> Step:

While inserting the other 4 legs, the Hirose 50 pin connector will, at the same time, match into the receptacle on the PCB.

Please be sure the direction of the force exerted on the clip/module is at a 45° angle downwards (as suggested by the arrow in the schematic) and not vertically at 90°.

### Part Number Table

Description	Part Number
Clip, PCB, MC55i	GT-MC55i-CLIP-F

**Disclaimer** This data sheet and its contents (the "Information") belong to the Premier Farnell Group (the "Group") or are licensed to it. No licence is granted for the use of it other than for information purposes in connection with the products to which it relates. No licence of any intellectual property rights is granted. The Information is subject to change without notice and replaces all data sheets previously supplied. The Information supplied is believed to be accurate but the Group assumes no responsibility for its accuracy or completeness, any error in or omission from it or for any use made of it. Users of this data sheet should check for themselves the Information and the suitability of the products for their purpose and not make any assumptions based on information included or omitted. Liability for loss or damage resulting from any reliance on the Information or use of it (including liability resulting from negligence or where the Group was aware of the possibility of such loss or damage arising) is excluded. This will not operate to limit or restrict the Group's liability for death or personal injury resulting from its negligence. SPC Multicomp is the registered trademark of the Group. © Premier Farnell plc 2009.