

# **Blackfin® Audio EZ-Extender® Manual**

Revision 2.1, May 2007

Part Number  
82-000195-01

Analog Devices, Inc.  
One Technology Way  
Norwood, Mass. 02062-9106



## **Copyright Information**

©2007 Analog Devices, Inc., ALL RIGHTS RESERVED. This document may not be reproduced in any form without prior, express written consent from Analog Devices, Inc.

Printed in the USA.

## **Limited Warranty**

The Blackfin Audio EZ-Extender is warranted against defects in materials and workmanship for a period of one year from the date of purchase from Analog Devices or from an authorized dealer.

## **Disclaimer**

Analog Devices, Inc. reserves the right to change this product without prior notice. Information furnished by Analog Devices is believed to be accurate and reliable. However, no responsibility is assumed by Analog Devices for its use; nor for any infringement of patents or other rights of third parties which may result from its use. No license is granted by implication or otherwise under the patent rights of Analog Devices, Inc.

## **Trademark and Service Mark Notice**

The Analog Devices logo, Blackfin, VisualDSP++, EZ-KIT Lite, and EZ-Extender are registered trademarks of Analog Devices, Inc.

All other brand and product names are trademarks or service marks of their respective owners.

## Regulatory Compliance

The Blackfin Audio EZ-Extender has been certified to comply with the essential requirements of the European EMC directive 89/336/EEC (inclusive 93/68/EEC) and, therefore, carries the “CE” mark.

The Blackfin Audio EZ-Extender had been appended to Analog Devices Development Tools Technical Construction File referenced “DSPTOOLS1” dated December 21, 1997 and was awarded CE Certification by an appointed European Competent Body and is on file.



The EZ-KIT Lite evaluation system contains ESD (electrostatic discharge) sensitive devices. Electrostatic charges readily accumulate on the human body and equipment and can discharge without detection. Permanent damage may occur on devices subjected to high-energy discharges. Proper ESD precautions are recommended to avoid performance degradation or loss of functionality. Store unused EZ-KIT Lite boards in the protective shipping package.





# CONTENTS

## PREFACE

Product Overview .....	vii
Purpose of This Manual .....	viii
Intended Audience .....	ix
Manual Contents .....	ix
What's New in This Manual .....	x
Technical or Customer Support .....	x
Supported Products .....	xi
Product Information .....	xi
Related Documents .....	xi
Notation Conventions .....	xiii

## AUDIO EZ-EXTENDER INTERFACES

Audio EZ-Extender Setup .....	1-1
Analog Audio Interface .....	1-2
Digital Audio Interface .....	1-4

## AUDIO EZ-EXTENDER HARDWARE REFERENCE

System Architecture .....	2-2
Configuration Jumpers and Switches .....	2-4

## CONTENTS

ADSP-BF537 EZ-KIT Lite Select Jumper (JP1.1/2) .....	2-5
EZ-KIT Lite SPORT0 Enable Jumper (JP1.3/4) .....	2-6
EZ-KIT Lite SPORT1 Enable Jumper (JP1.5/6) .....	2-6
SPORT Select Jumper (JP1.7/8) .....	2-6
AD1938 MCLK Source Jumper (JP2) .....	2-6
SPDIF Loopback Jumper (JP4) .....	2-7
Analog Input Gain Switches (SW1–4) .....	2-7

## AUDIO EZ-EXTENDER BILL OF MATERIALS

## AUDIO EZ-EXTENDER SCHEMATIC

Title Page .....	B-1
Expansion Interface (1 and 2) .....	B-2
Expansion Interface (3) .....	B-3
Configuration .....	B-4
ADAV801–Digital Audio .....	B-5
AD1938–Analog Audio .....	B-6
Analog In 1 .....	B-7
Analog In 2 .....	B-8
Analog In 3 .....	B-9
Analog In 4 .....	B-10
Analog Out 1 .....	B-11
Analog Out 2 .....	B-12

## INDEX

# PREFACE

Thank you for purchasing the Blackfin<sup>®</sup> Audio EZ-Extender<sup>®</sup>, Analog Devices, Inc. (ADI) daughter board to the EZ-KIT Lite<sup>®</sup> evaluation system for the ADSP-BF533, ADSP-BF537, and ADSP-BF561 Blackfin processors.

The Blackfin processors are embedded processors that support a Media Instruction Set Computing (MISC) architecture. This architecture is the natural merging of RISC, media functions, and digital signal processing characteristics towards delivering signal processing performance in a microprocessor-like environment.

The EZ-KIT Lite and Audio EZ-Extender are designed to be used in conjunction with the VisualDSP++<sup>®</sup> development environment. VisualDSP++ offers a powerful programming tool with new flexibility that significantly decreases the time required to port software code to a processor, reducing time-to-market.

To learn more about Analog Devices development software, go to <http://www.analog.com/processors/tools/>.

## Product Overview

The Blackfin Audio EZ-Extender is a separately sold daughter board that plugs onto the expansion interface of the ADSP-BF533, ADSP-BF537, or ADSP-BF561 EZ-KIT Lite evaluation system. The daughter board aids the design and prototyping phases of ADSP-BF533, ADSP-BF537, and ADSP-BF561 processor targeted applications.

## Purpose of This Manual

The board extends the capabilities of the evaluation system by providing a connection to three audio codecs, including two analog audio codecs and one dual analog/digital audio codec with an interface to digital Sony Philips Digital Interface (SPDIF) audio.

The following is a list of the Blackfin Audio EZ-Extender interfaces.

- Analog audio interface
  - ✓ AD1938 – Analog Devices 192 kHz audio codecs
  - ✓ Four stereo analog audio inputs via RCA jacks
  - ✓ Eight stereo analog audio outputs via RCA jacks
- Digital audio interface
  - One ADAV801 – Analog Devices SPDIF transceiver with sample rate converter
    - ✓ One SPDIF input via a RCA jack
    - ✓ One SPDIF output via a RCA jack
- Expansion interface on both sides of the board for stacking other EZ-Extender boards

Before using any of the interfaces, follow the setup procedure in [“Audio EZ-Extender Setup” on page 1-1](#).

Example programs are available to demonstrate the capabilities of the Blackfin Audio EZ-Extender board.

## Purpose of This Manual

The *Blackfin Audio EZ-Extender Manual* describes the operation and configuration of the components on the extension board. A schematic and a bill of materials are provided as a reference for future Blackfin processor board designs.



## Intended Audience

This manual is a user's guide and reference to the Blackfin Audio EZ-Extender. Programmers who are familiar with the Analog Devices Blackfin processor architecture, operation, and development tools are the primary audience for this manual.

Programmers who are unfamiliar with VisualDSP++ or EZ-KIT Lite evaluation software should refer to the *ADSP-BF533*, *ADSP-BF537*, or *ADSP-BF561 Evaluation System Manual*, VisualDSP++ online Help, and user's or getting started guides. For the locations of these documents, refer to “[Related Documents](#)”.

## Manual Contents

The manual consists of:

- Chapter 1, “[Audio EZ-Extender Interfaces](#)” on page 1-1  
Provides basic board information.
- Chapter 2, “[Audio EZ-Extender Hardware Reference](#)” on page 2-1  
Provides information on the hardware aspects of the board.
- Appendix A, “[Audio EZ-Extender Bill Of Materials](#)” on page A-1  
Provides a list of components used to manufacture the EZ-Extender board.
- Appendix B, “[Audio EZ-Extender Schematic](#)” on page B-1  
Provides the resources to allow EZ-KIT Lite board-level debugging or to use as a reference design.



Appendix B now is part of the online Help. The latest schematics for the product can be found on the Analog Devices Web site, [www.analog.com/processors](http://www.analog.com/processors).

# What's New in This Manual

This *Blackfin Audio EZ-Extender Manual* has been updated for the latest revision of VisualDSP++.

## Technical or Customer Support

You can reach Analog Devices, Inc. Customer Support in the following ways:

- Visit the Embedded Processing and DSP products Web site at <http://www.analog.com/processors/technicalSupport>
- E-mail tools questions to [processor.tools.support@analog.com](mailto:processor.tools.support@analog.com)
- E-mail processor questions to [processor.support@analog.com](mailto:processor.support@analog.com) (World wide support)  
[processor.europe@analog.com](mailto:processor.europe@analog.com) (Europe support)  
[processor.china@analog.com](mailto:processor.china@analog.com) (China support)
- Phone questions to **1-800-ANALOGD**
- Contact your Analog Devices, Inc. local sales office or authorized distributor
- Send questions by mail to:  
Analog Devices, Inc.  
One Technology Way  
P.O. Box 9106  
Norwood, MA 02062-9106  
USA

## Supported Products

The Blackfin Audio EZ-Extender is designed as an extension board to the ADSP-BF533, ADSP-BF537, and ADSP-BF561 EZ-KIT Lite evaluation systems.

## Product Information

You can obtain product information from the Analog Devices Web site, from the product CD-ROM, or from the printed publications (manuals).

Analog Devices is online at [www.analog.com](http://www.analog.com). Our Web site provides information about a broad range of products—analogue integrated circuits, amplifiers, converters, and digital signal processors.

## Related Documents

For information on product related development software, see the following publications.

Table 1. Related Processor Publications

Title	Description
<ul style="list-style-type: none"> <li>• <i>ADSP-BF533 Embedded Processor Datasheet</i></li> <li>• <i>ADSP-BF536/ADSP-BF537 Embedded Processor Datasheet</i></li> <li>• <i>ASP-BF561 Blackfin Embedded Symmetric Multi-Processor Datasheet</i></li> </ul>	General functional description, pinout, and timing.

## Product Information

Table 1. Related Processor Publications (Cont'd)

Title	Description
<ul style="list-style-type: none"><li>• <i>ADSP-BF533 Blackfin Processor Hardware Reference</i></li><li>• <i>ADSP-BF537 Blackfin Processor Hardware Reference</i></li><li>• <i>ASP-BF561 Blackfin Processor Hardware Reference</i></li></ul>	Description of internal processor architecture and all register functions
<i>Blackfin Processor Instruction Set Reference</i>	Description of all allowed processor assembly instructions.

Table 2. Related VisualDSP++ Publications

Title	Description
<ul style="list-style-type: none"><li>• <i>ADSP-BF533 EZ-KIT Lite Evaluation System Manual</i></li><li>• <i>ADSP-BF537 EZ-KIT Lite Evaluation System Manual</i></li><li>• <i>ADSP-BF561 EZ-KIT Lite Evaluation System Manual</i></li></ul>	Description of the EZ-KIT Lite features and usage. Note: For the ADSP-BF537 EZ-KIT Lite, there is additional <i>Getting Started with ADSP-BF537 EZ-KIT Lite</i> .
<i>VisualDSP++ User's Guide</i>	Description of VisualDSP++ features and usage
<i>VisualDSP++ Assembler and Preprocessor Manual</i>	Description of the assembler function and commands
<i>VisualDSP++ C/C++ Compiler and Library Manual for Blackfin Processors</i>	Description of the compiler function and commands for Blackfin processors
<i>VisualDSP++ Linker and Utilities Manual</i>	Description of the linker function and commands
<i>VisualDSP++ Loader and Utilities Manual</i>	Description of the loader function and commands

All documentation is available online. Most documentation is available in printed form.

Visit the Technical Library Web site to access all processor and tools manuals and data sheets:



<http://www.analog.com/processors/resources/technicalLibrary>.

## Notation Conventions

Text conventions used in this manual are identified and described as follows.

Example	Description
{this   that}	Alternative required items in syntax descriptions appear within curly brackets and separated by vertical bars; read the example as <i>this</i> or <i>that</i> . One or the other is required.
[this   that]	Optional items in syntax descriptions appear within brackets and separated by vertical bars; read the example as an optional <i>this</i> or <i>that</i> .
[this,...]	Optional item lists in syntax descriptions appear within brackets delimited by commas and terminated with an ellipsis; read the example as an optional comma-separated list of <i>this</i> .
.SECTION	Commands, directives, keywords, and feature names are in text with letter gothic font.
<i>filename</i>	Non-keyword placeholders appear in text with italic style format.

## Notation Conventions

Example	Description
	<p><b>Note:</b> For correct operation, ...</p> <p>A Note provides supplementary information on a related topic. In the online version of this book, the word <b>Note</b> appears instead of this symbol.</p>
	<p><b>Caution:</b> Incorrect device operation may result if ...</p> <p><b>Caution:</b> Device damage may result if ...</p> <p>A Caution identifies conditions or inappropriate usage of the product that could lead to undesirable results or product damage. In the online version of this book, the word <b>Caution</b> appears instead of this symbol.</p>
	<p><b>Warning:</b> Injury to device users may result if ...</p> <p>A Warning identifies conditions or inappropriate usage of the product that could lead to conditions that are potentially hazardous for the devices users. In the online version of this book, the word <b>Warning</b> appears instead of this symbol.</p>

 Additional conventions, which apply only to specific chapters, may appear throughout this document.

# 1 AUDIO EZ-EXTENDER INTERFACES

This chapter provides the Audio EZ-Extender setup procedure and describes two types of interfaces the extender supports.

The information is presented in the following order.

- [“Audio EZ-Extender Setup” on page 1-1](#)
- [“Analog Audio Interface” on page 1-2](#)
- [“Digital Audio Interface” on page 1-4](#)

## Audio EZ-Extender Setup

It is very important to set up all of the components of the system containing the Audio EZ-Extender before applying power to that system. The following procedure is recommended for the correct setup.

Power your system when these steps are completed:

1. Read the applicable design interface section in this chapter—the text provides an overview of the capabilities of the interface.
2. Read [“System Architecture” on page 2-2](#) to understand the physical connections of the daughter board. For detailed information, refer to [“Audio EZ-Extender Schematic” on page B-1](#).
3. Refer to the readme text files in the `...\Blackfin\Examples\Audio EZ-EXTENDER` subdirectories of the VisualDSP++ installation directory for information on how to con-

## Analog Audio Interface

figure jumpers and switches on both the Audio EZ-Extender and EZ-KIT Lite boards. For custom setups use [“System Architecture” on page 2-2](#) in conjunction with [“Configuration Jumpers and Switches” on page 2-4](#).

## Analog Audio Interface

For analog audio applications, the Audio EZ-Extender uses two AD1938 multichannel 192 kHz audio codecs. The AD1938 is a high-performance, single-chip codec chip that provides four analog-to-digital converters (ADCs) with differential inputs and eight digital-to-analog converters (DACs) with single-ended outputs. The DAC outputs operate using ADI's patented multibit sigma-delta architecture. The chip provides auxiliary input and output SPORTs for connecting to other codecs, increasing the number of channels a single SPORT uses. A serial peripheral interface (SPI) port is included, allowing the microcontroller to adjust volume and many other audio parameters.

For a picture of the audio interface connections, see [Figure 2-1 on page 2-3](#). For more detailed information, see [“Audio EZ-Extender Schematic” on page B-1](#). The two AD1938 chips (referred to as AD1938\_A and AD1938\_B in the block diagrams) connect in parallel to a single SPORT. The chips connect for a time-division multiplexed (TDM) output mode:

- At a 48 kHz sample rate, TDM mode allows up to 16 channels of data to be sent from each chip in each direction. Each chip uses four of the 16 input channels and eight of the 16 output channels. The number of channels can be set up in the control registers and is dependant on the sample rate. As the sample rate increases, the number of possible channels decreases.



- At 96 kHz, the AD1938 operates with a maximum of eight channels in each direction. At 96 kHz, all of the TDM channels are used by all analog outputs, but there are still four extra input channels, two of which can be used by the digital inputs.
- At the 192 kHz sample rate, a maximum of four channels in each direction can be used, meaning that four of the output channels cannot be used.

The auxiliary SPORTs of the AD1938\_A codec connect to the ADAV801's auxiliary SPORT (see [“System Architecture” on page 2-2](#) for more information). The Sony Philips Digital Interface (SPDIF) stream requires two channels of the TDM stream for each direction: two channels for left and right input audio, and two channels for left and right output audio.

If the AD1938 runs at the 48 kHz sample rate, both the input and output digital streams can be put into the TDM stream. In this case, all of the clocks in the system must be set up relative to the recovered clock from the SPDIF input.

At the 96 kHz sample rate, only the SPDIF inputs is able to be added to the TDM stream. This is because at 96 kHz, only eight outputs channels are available and they are all being used by the outputs.

The internal phase-locked loop (PLL) of the AD1938 codec can be configured to generate all of the clocking and frame sync signals. The source clock of the PLL can be from either the serial port frame sync or an externally supplied clock. The external master clock (MCLK) comes from the ADAV801 codec. A jumper (JP2) allows the master clock to come directly from the SYSCLK3 pin of the ADAV801 or from a divided version of the SYSCLK1, either divided by 2 or 4. The divided clocks are necessary when a sample rate less than 32 kHz is required. Otherwise, a signal clock frequency at the MCLK pin of the AD1938 can generate the 48 kHz, 96 kHz, or 192 kHz sample rate.

## Digital Audio Interface

The analog input pins of the AD1938's input signals operate in the range from 0 V<sub>rms</sub> to 1 V<sub>rms</sub>. To allow larger signals to be input at the RCA jacks, the input amplifiers (external to the AD1938) are capable of attenuating the signals. See “[Configuration Jumpers and Switches](#)” on page 2-4 for more information.

The analog output pins of the AD1938's output signals operate in the range from 0 V<sub>rms</sub> to 1 V<sub>rms</sub>. The output amplifiers are set to a gain of 1.5x, giving the system unity gain when switches SW1-4 are all ON.

Example programs demonstrating the capabilities of the audio interface are included in the `..\Blackfin\Examples\Audio\EZ-EXTENDER` subdirectories of the VisualDSP++ installation directory.

For more information about the AD1938 codecs, go to <http://www.analog.com> and search for AD1938.

## Digital Audio Interface

For digital audio applications, the Audio EZ-Extender uses the ADAV801 codec chip. The ADAV801 chip has an analog stereo input, analog stereo output, digital stereo input, and a digital stereo output. In addition to these inputs and outputs, the ADAV801 also has an internal sample rate converter, which can be used to change the sample rate between the different interfaces. On the Audio EZ-Extender, the analog input and outputs are not used. The digital interface can operate at up to a 200 kHz sample rate. The ADAV801 operates in the I<sup>2</sup>S mode, which allows only two channels (left and right) of input and two channels of output. It also has an auxiliary serial port for connecting to other devices. The configuration registers are configured using an SPI port connected to the processor.

The ADAV801 has two internal PLLs, which can produce all of the necessary internal clocks for the different interfaces of the chip. An external 27 MHz oscillator is used as a clock source for the PLLs. The external clocks, which also go to the AD1938 codecs, are generated from the PLLs.

The recovered clock from the SPDIF input can be used as a clock input for the serial ports, as well as for the generated external clock output SYSCLK3.

The primary serial port of the ADAV801 codec connects to the processor on the mother board, while the secondary serial port connects to the AD1938\_A codec. For a picture of the digital audio interface connections, see “[System Architecture](#)” on page 2-3. For more detailed information, see “[Audio EZ-Extender Schematic](#)” on page B-1. The internal routing of the different interfaces of the ADAV801 is completely configurable. The SPDIF input and output can be separately routed to either or both the primary and secondary serial ports.

Example programs demonstrating the capabilities of the digital audio interface are included in the in the ...\Blackfin\Examples\Audio EZ-EXTENDER subdirectories of the VisualDSP++ installation directory.

For more information about the ADAV801 codecs, go to <http://www.analog.com> and search for ADAV801.

# Digital Audio Interface

# 2 AUDIO EZ-EXTENDER HARDWARE REFERENCE

This chapter describes the hardware design of the Blackfin Audio EZ-Extender.

The following topics are covered.

- [“System Architecture” on page 2-2](#)  
Describes the configuration of the daughter board and explains how the board components interface with the processor and EZ-KIT Lite.
- [“Configuration Jumpers and Switches” on page 2-4](#)  
Describes the function of the configuration jumpers and switches.

# System Architecture

A picture of the board layout, connector and jumper locations is shown in [Figure 2-2 on page 2-5](#). A block diagram of the Audio EZ-Extender is shown in [Figure 2-1](#).

The analog audio interface consists of two AD1938 audio codecs (referred to as AD1938\_A and AD1938\_B codecs), which use one of the processor's serial ports (SPORTs). All of the clock and frame sync signals must be driven by one of the AD1938 chips. The analog audio interface is configured for the time-division multiplexed (TDM) serial mode. In the TDM mode, a single clock and frame sync are used to transmit and receive the data. The data signals of the AD1938\_A codec connect to the processor's primary SPORT TX and RX pins, and the data signals of the AD1938\_B codec connect to the secondary SPORT TX and RX pins (see [“Analog Audio Interface” on page 1-2](#)).

The digital audio interface consists of the ADAV801 codec. The codec chip communicates in the I<sup>2</sup>S mode. In the I<sup>2</sup>S mode, the transmit and receive clock, along with the frame sync signals, are set individually to transmit sample rate that is different from the receive sample rate.

The ADAV801 codec has a secondary transmit and receive SPORT, which is interfaced with the auxiliary SPORT of the AD1938\_A codec. The interface operates in the I<sup>2</sup>S mode and is mastered by the ADAV801 chip. The interface allows the digital audio data streams to be multiplexed into the analog audio data stream, facilitating access to all of the data signals via a single SPORT. This is dependent on the sample rate, as described in [“Analog Audio Interface” on page 1-2](#).

A jumper setting allows the routing of the processor's SPORTs to be swapped with the SPORTs of the analog and digital interfaces. If the SPORT on the mother board is already in use, this feature allows either of

# Audio EZ-Extender Hardware Reference

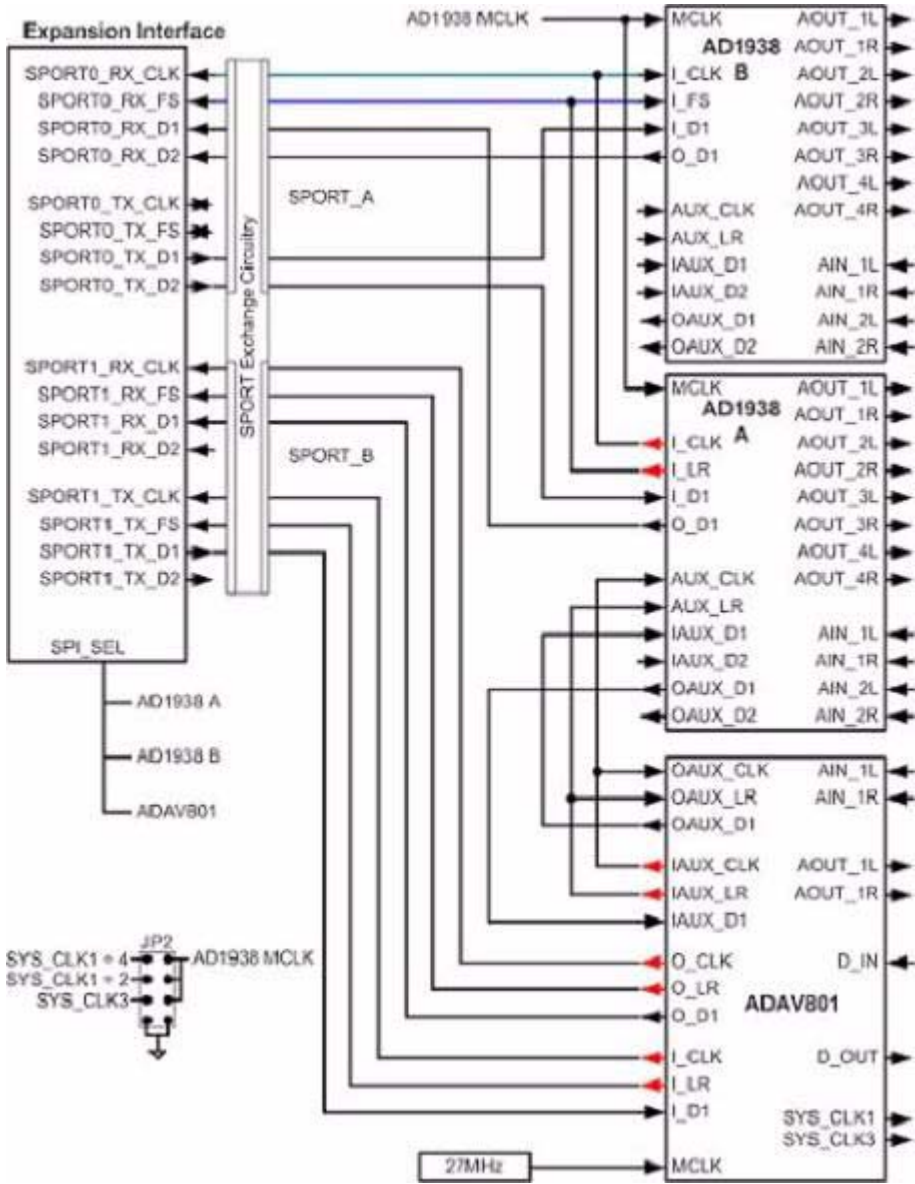

Figure 2-1. System Architecture

## Configuration Jumpers and Switches

the audio interfaces to be used instead. In addition, each SPORT individually can be disabled and not driven by the Audio EZ-Extender on the mother board. For more information, see the following sections:

- [“SPORT Select Jumper \(JP1.7/8\)” on page 2-6](#)
- [“EZ-KIT Lite SPORT1 Enable Jumper \(JP1.5/6\)” on page 2-6](#)
- [“EZ-KIT Lite SPORT0 Enable Jumper \(JP1.3/4\)” on page 2-6.](#)

Each of the Audio EZ-Extender’s ICs (AD1938\_A, AD1938\_B, and ADAV801) is configured using the SPI interface of the processor. Each chip includes its own chip select pin. On the ADSP-BF537 EZ-KIT Lite, the location of the chip select signals on the expansion interface is different from that location on the ADSP-BF533 and ADSP-BF561 EZ-KIT Lites. A jumper is used to define for which EZ-KIT Lite to set up the SPI select signals. For more information, see [“ADSP-BF537 EZ-KIT Lite Select Jumper \(JP1.1/2\)” on page 2-5.](#)

All of the expansion interface signals are passed directly through the board from the EZ-KIT Lite to another set of expansion interface connectors. This allows other EZ-Extender boards to be attached to the Audio EZ-Extender.

## Configuration Jumpers and Switches

Before using the Blackfin Audio EZ-Extender, follow the steps in [“Audio EZ-Extender Setup” on page 1-1.](#)

[Figure 2-2](#) shows the locations of all of the jumper headers. The jumper headers are divided to show the placement and rotation of each jumper. The jumpers are described by the pins of the header on which the jumpers can be placed. For example, JP1.1/2 refers to a single jumper that can be placed across pins 1 and 2 of JP1. The dark pin indicates pin 1 of each header.



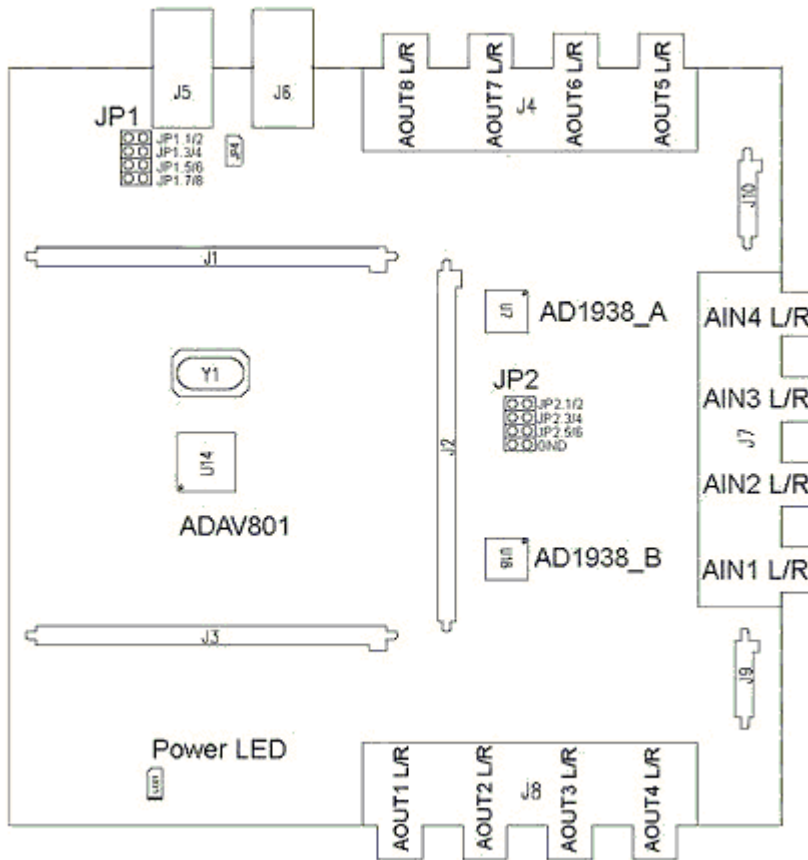

Figure 2-2. Jumper Locations

## ADSP-BF537 EZ-KIT Lite Select Jumper (JP1.1/2)

When interfacing the Audio EZ-Extender with the ADSP-BF537 EZ-KIT Lite, insert the JP1.1/2 jumper to route the ADSP-BF537 EZ-KIT Lite SPI select signals to the corresponding codec.

## Configuration Jumpers and Switches

### EZ-KIT Lite SPORT0 Enable Jumper (JP1.3/4)

Installing a jumper at this location enables the SPORT0 signals of the EZ-KIT Lite to drive and be driven by the Audio EZ-Extender. Do not install this jumper if SPORT0 is used elsewhere on the mother board.

### EZ-KIT Lite SPORT1 Enable Jumper (JP1.5/6)

Installing a jumper at this location enables the SPORT1 signals of the EZ-KIT Lite to drive and be driven by the Audio EZ-Extender. Do not install this jumper if SPORT0 is used elsewhere on the mother board.

### SPORT Select Jumper (JP1.7/8)

The JP1.7/8 jumper determines how SPORT0 and SPORT1 are routed to the analog SPORT (SPORT\_A) and the digital SPORT interface (SPORT\_B). See [Figure 2-1 on page 2-3](#) for more details. The following table describes the jumper connections.

SPORT_SEL (JP1.7/8) Setting	Connection
Not installed	SPORT0 = SPORT_B (digital) SPORT1 = SPORT_A (analog)
Installed	SPORT0 = SPORT_A (analog) SPORT1 = SPORT_B (digital)

### AD1938 MCLK Source Jumper (JP2)

The JP2 jumper determines the source of the master clock (MCLK) of the AD1938 audio codecs. The standard configuration connects the SYSCLK3 pin of the ADAV801 codec to MCLK by installing the JP2.5/6 jumper. Two other jumper positions, JP2.1/2 and JP2.3/4, connect MCLK to the ADAV801 codec's SYSCLK1 pin divided by 4 and 2, respectively. These positions can be used to supply the AD1938 codec with lower master clock frequencies to reach the lower sample rates. For more information

about the `SYSCLK1` and `SYSCLK3` pins, refer to the AD4V801 datasheet. For more information on the `MCLK` frequencies and sample rates, see the AD1938 datasheet.

## SPDIF Loopback Jumper (JP4)

The `JP4` jumpers are used for test purposes only; the SPDIF jumpers loop-back the digital output signals to the digital input.

## Analog Input Gain Switches (SW1–4)

The `SW1-4` switches allow the gain of each analog input to be changed from  $1/(1.5)$  to  $1/(2.12)$ . This is useful when the input signals are too large for the AD1938 codec to handle. The following table shows which switch position corresponds to each analog input channel.

Switch Position	Analog Input Channel
SW1.1	AIN1_L
SW1.2	AIN1_R
SW2.1	AIN2_L
SW2.2	AIN2_R
SW3.1	AIN3_L
SW3.2	AIN3_R
SW4.1	AIN4_L
SW4.2	AIN4_R

When the switch is ON, the gain is set to  $1/(1.5)$ . When the switch is OFF, the gain is set to  $1/(2.12)$ .

## Configuration Jumpers and Switches

# A AUDIO EZ-EXTENDER BILL OF MATERIALS

The bill of materials corresponds to “[Audio EZ-Extender Schematic](#)” on [page B-1](#). Please check the latest schematics on the Analog Devices website:

<http://www.analog.com/Processors/Processors/DevelopmentTools/technicalLibrary/manuals/DevToolsIndex.html#Evaluation%20Kit%20Manuals>.

Ref.	Qty.	Description	Reference Designator	Manufacturer	Part Number
1	1	SN74LVC1G08 SOT23-5	U1	TI	SN74LVC1G08DBVR
2	1	74LVC74A TSSOP14	U9	PHILIPS	74LVC74APW
3	1	27MHZ OSC011	Y1	DIGI-KEY	300-8571-1-ND
4	6	SN74LVC257 TSSOP16	U3,U6,U10-11,U13, U16	DIGI-KEY	296-8506-1-ND
5	2	AD1938XSTZ LQFP48	U7,U18	ANALOG DEVICES	AD1938XSTZ
6	1	ADAV801ASTZ LQFP64	U14	ANALOG DEVICES	ADAV801ASTZ
7	8	AD8608ARUZ TSSOP14	U4-5,U8,U12,U15,U 19,U21-22	ANALOG DEVICES	AD8608ARUZ
8	3	RCA4X2 CON011	J4,J7-8	SWITCH- CRAFT	PJRS4X2U01X
9	2	RCA1X1 CON012	J5-6	SWITCH- CRAFT	PJRN1X1U01X
10	3	0.0545x2 CON018	P1-3	SAMTEC	TFC-145-32-F-D

Ref.	Qty.	Description	Reference Designator	Manufacturer	Part Number
11	3	.0545X2CON019	J1-3	SAMTEC	SFC-145-T2-F-D-A
12	2	0.0510X2CON040	J9-10	SAMTEC	SFC-110-T2-F-D-A
13	4	DIP2 SWT020	SW1-4	C&K	TDA02H0SB1
14	1	IDC2X1 IDC2X1	JP4	FCI	90726-402HLF
15	5	IDC1X1 IDC1X1	TP1-2,TP6,TP8-9	SULLINS	PEC01SAAN
16	2	IDC4X2 IDC4X2	JP1-2	SULLINS	GEC04DAAN
17	2	22PF 50V 5% 0805	C152-153	AVX	08055A220JAT
18	16	600 100MHZ 200MA 0603	FER1-16	DIGI-KEY	490-1014-2-ND
19	1	750 1/10W 5% 0805	R72	VISHAY	CRCW0805750RJNEA
20	1	.082UF 50V 5% 0805	C73	AVX	08055C823JAT2A
21	15	10UF 6.3V 10% 0805	C22,C34-35,C52, C61,C85,C87,C158, C161,C167,C172, C174-175,C182, C185	AVX	080560106KAT2A
22	1	2.2UF 10V 10% 0805	C72	AVX	0805ZD225KAT2A
23	1	107.0 1/10W 1% 0805	R110	DIGI-KEY	311-107CRTR-ND
24	48	0.1UF 16V 10% 0603	C31,C55,C58,C76, C86,C125-130, C135,C138, C140-143,C146-147, C149-150,C154, C157,C162-165, C169-171,C176-177, C179,C183-184, C189-191,C194-195, C197,C199-200, C203,C205-206, C209-210	AVX	0603YC104KAT2A

## Audio EZ-Extender Bill Of Materials

Ref.	Qty.	Description	Reference Designator	Manufacturer	Part Number
25	1	0.01UF 16V 10% 0603	C116	AVX	0603YC103KAT2A
26	4	10UF 10V +80/-20% 0805	C9,C134,C186,C207	PANASONIC	ECJ-2FF1A106Z
27	40	4.7UF 6.3V 20% 0603	C20-21,C28-29, C38-39,C50-51, C59-60,C68-69, C77-78,C88-89, C117-124,C137, C144,C155,C159, C173,C180,C196, C201,C212-219	PANASONIC	ECJ-1VB0J475M
28	2	.033UF 25V 10% 0603	C44-45	AVX	06033C333KAT2A
29	12	22 1/10W 5% 0603	R27,R55,R58-60, R65,R128,R130-131, R133,R142-143	VISHAY	CRCW060322R0JNEA
30	9	0 1/10W 5% 0603	R31,R36,R45,R51, R63,R68,R77,R81, R203	PHYCOMP	232270296001L
31	16	237.0 1/10W 1% 0603	R25-26,R39-42, R53-54, R56-57,R70-71, R73-74,R83-84	DIGI-KEY	311-237HRTR-ND
32	16	3.32K 1/10W 1% 0603	R171-178,R186-193	DIGI-KEY	311-3.32KHRTR-ND
33	16	49.9K 1/10W 1% 0603	R111-118,R144-151	DIGI-KEY	311-49.9KHRTR-ND
34	16	604.0 1/10W 1% 0603	R1-8,R101-108	DIGI-KEY	311-604HRTR-ND
35	6	10.0K 1/10W 1% 0603	R119-120,R122-123, R153-154	DIGI-KEY	311-10.0KHRTR-ND

Ref.	Qty.	Description	Reference Designator	Manufacturer	Part Number
36	16	5.76K 1/10W 1% 0603	R29-30,R34-35, R43-44,R49-50, R61-62,R66-67, R75-76,R79-80	DIGI-KEY	311-5.76KHRTR-ND
37	8	120PF 50V 5% 0603	C23,C26,C41,C46,C 62, C65,C80,C82	AVX	06035A121JAT2A
38	16	100PF 50V 5% 0603	C25,C30,C43,C48, C64,C67,C79,C84, C133,C148,C151, C166,C168,C188, C193,C204	AVX	06035A101JAT2A
39	16	1000PF 50V 5% 0603	C18-19,C32-33, C36-37,C53-54, C56-57,C70-71, C74-75,C90-91	PANASONIC	ECJ-1VC1H102J
40	16	220PF 50V 5% 0603	C5-8,C10-13, C96-103	PANASONIC	ECJ-1VC1H221J
41	16	2200PF 50V 5% 0603	C108-115,C220-227	PANASONIC	ECJ-1VB1H222K
42	1	75.0 1/10W 1% 0603	R109	DALE	CRCW060375R0FKEA
43	16	270PF 50V 5% 0603	C1-4,C14-17, C92-95,C104-107	DIGI-KEY	311-1185-2-ND
44	1	243.0 1/10W 1% 0603	R121	VISHAY	CRCW0603243RFKEA
45	3	732.0 1/10W 1% 0603	R47-48,R152	VISHAY	CRCW0603732RFKEA
46	2	562.0 1/10W 1% 0603	R125,R136	VISHAY	CRCW0603562RFKEA
47	2	390PF 25V 5% 0603	C136,C192	AVX	06033A391FAT2A
48	2	1800PF 50V 5% 0805	C40,C49	PANASONIC	ECJ2VB1H182K





## Audio EZ-Extender Bill Of Materials

Ref.	Qty.	Description	Reference Designator	Manufacturer	Part Number
49	2	5600PF 16V 5% 0805	C132,C187	AVX	0805YA562JAT2A
50	8	28.0K 1/10W 1% 0603	R155,R157-158, R161-162,R165-166, R169	DIGI-KEY	311-28.0KHTR-ND
51	48	4.99K 1/16W 1% 0603	R9-24,R85-100, R170,R179-185, R194-201	VISHAY	CRCW06034K99FKEA
52	8	24.9K 1/10W 1% 0603	R126-127,R129, R132,R134-135, R138,R140	DIGI-KEY	311-24.9KHTR-ND
53	1	47UF 6.3V 10% B	CT1	PANASONIC	EEE0JA470WR
54	8	22.6K 1/16W 1% 0603	R124,R156, R159-160, R163-164,R167-168	VISHAY	CRCW060322K6FKEA
55	1	GREENLED001	LED1	PANASONIC	LN1361CTR

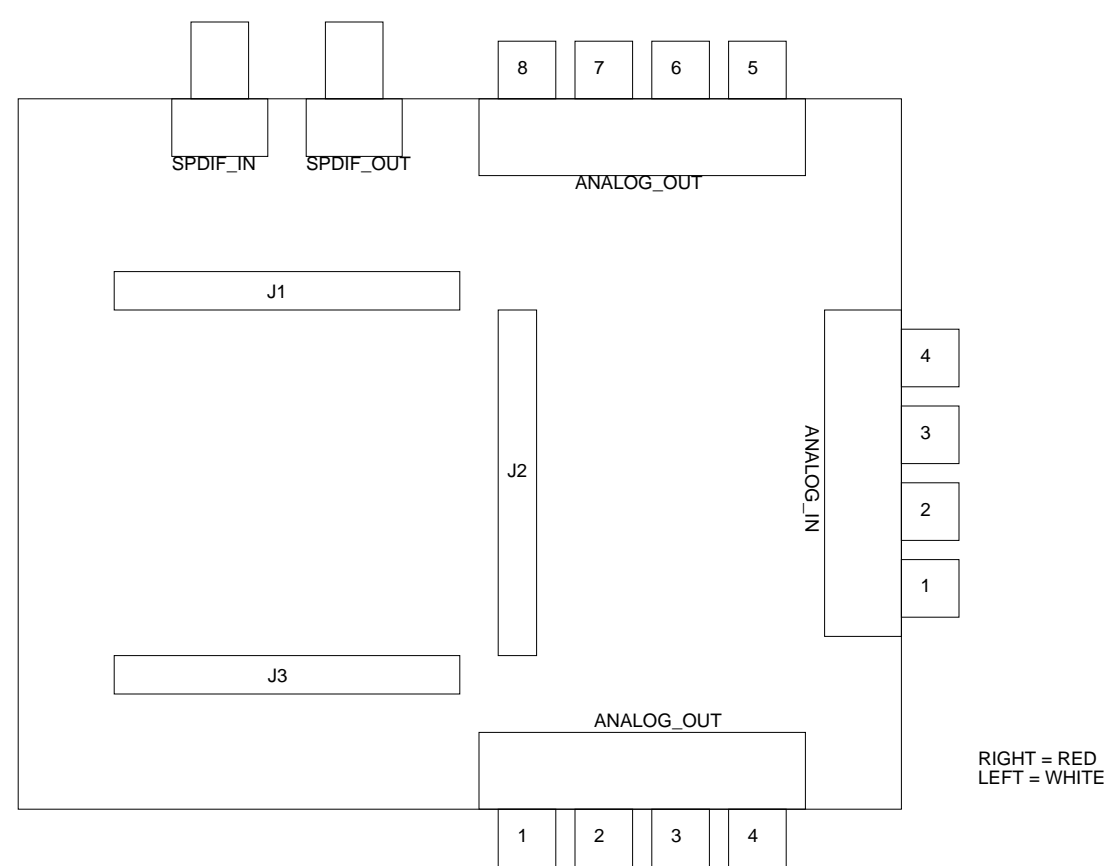

# Blackfin Audio EZ-Extender Schematic



 <b>ANALOG DEVICES</b>		20 Cotton Road Nashua, NH 03063 PH: 1-800-ANALOGD	
		<b>Title</b> BLACKFIN AUDIO EZ-EXTENDER TITLE	
<b>Size</b> C	<b>Board No.</b> A0195-2005	<b>Rev</b> 1.2C	
<b>Date</b> 5-23-2007_11:47	<b>Sheet</b> 1 of 12		

# EXPANSION INTERFACE (TYPE B)

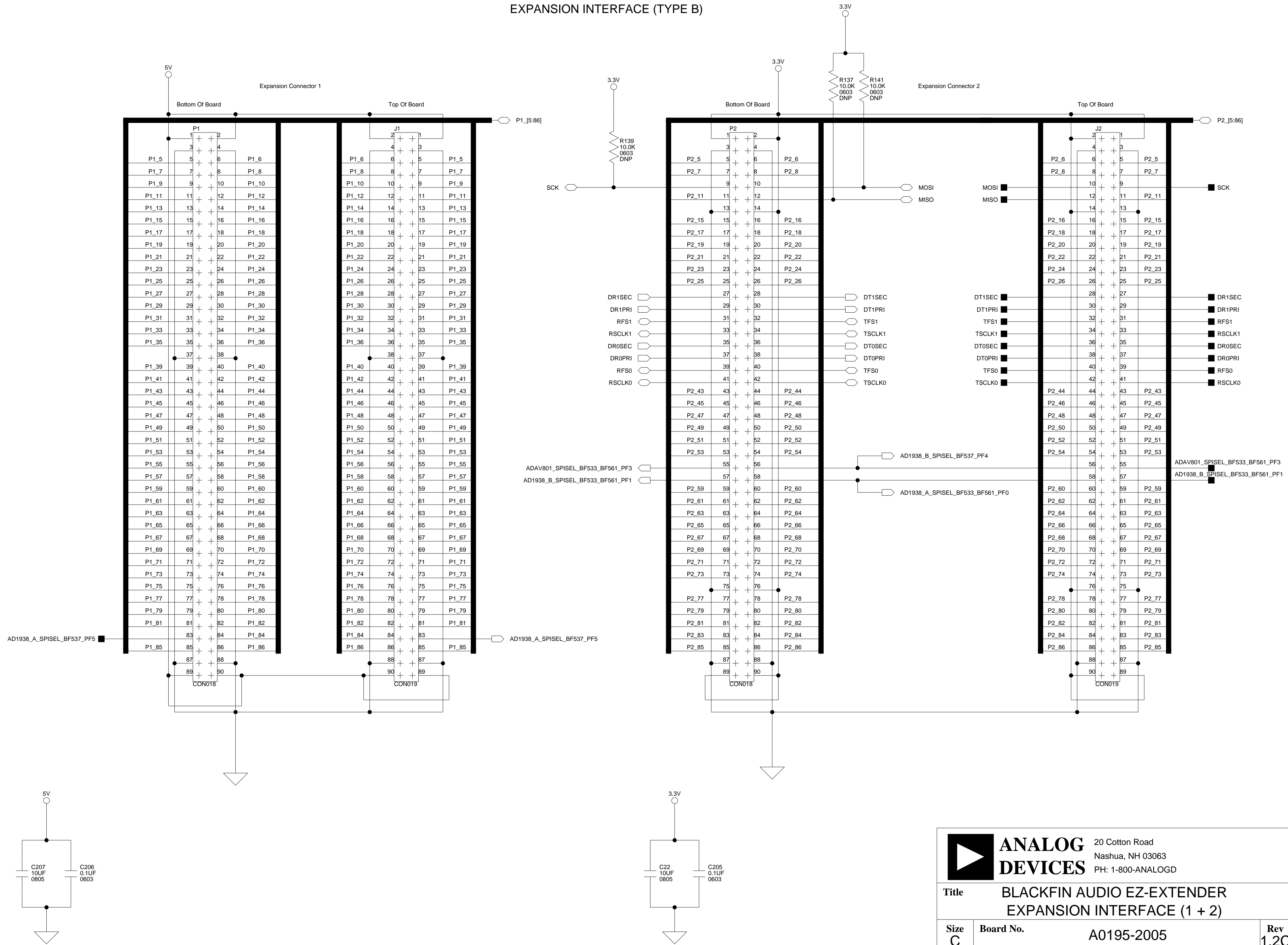

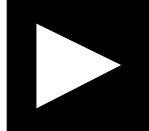
 <b>ANALOG DEVICES</b>		20 Cotton Road Nashua, NH 03063 PH: 1-800-ANALOGD	
		<b>Title</b> BLACKFIN AUDIO EZ-EXTENDER EXPANSION INTERFACE (1 + 2)	
<b>Size C</b>	<b>Board No.</b> A0195-2005	<b>Rev</b> 1.2C	
<b>Date</b> 5-23-2007_11:47	<b>Sheet</b> 2 of 12		

# EXPANSION INTERFACE (TYPE B)

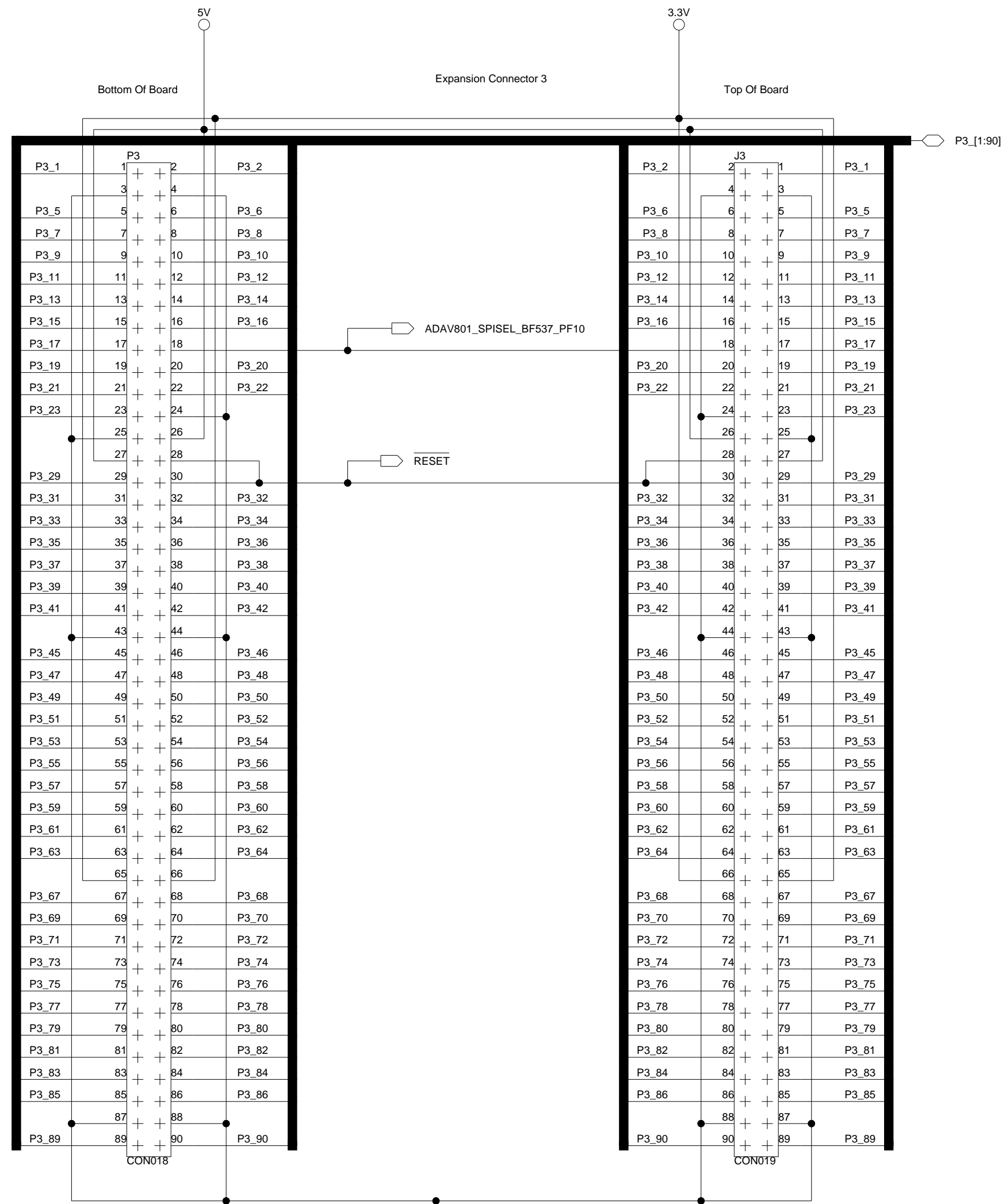

## For Test Purposes Only

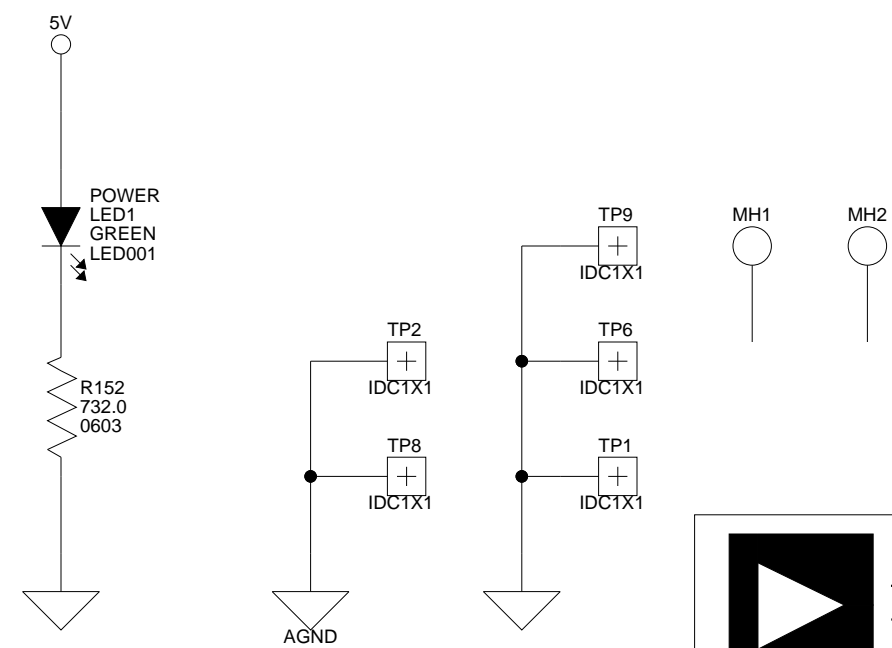
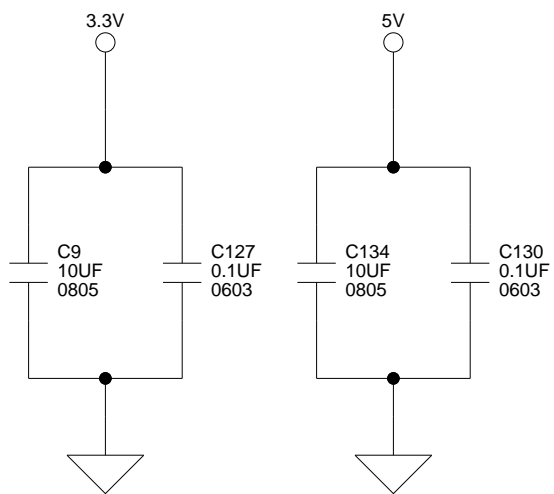
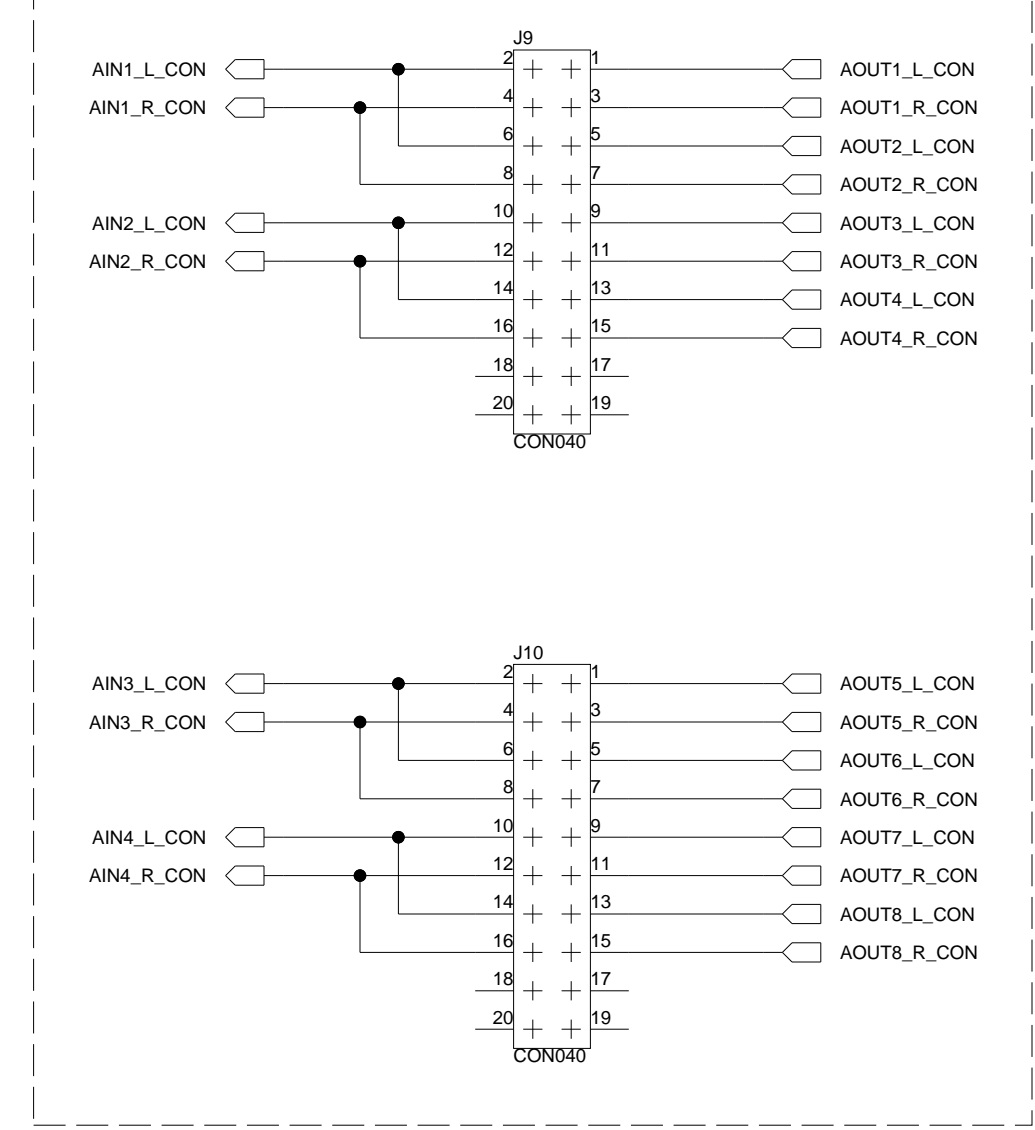

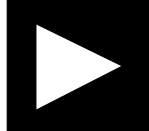
 <b>ANALOG DEVICES</b>		20 Cotton Road Nashua, NH 03063 PH: 1-800-ANALOGD	
		<b>Title</b> BLACKFIN AUDIO EZ-EXTENDER EXPANSION INTERFACE (3)	
<b>Size C</b>	<b>Board No.</b> A0195-2005	<b>Rev</b> 1.2C	
<b>Date</b> 5-23-2007_11:47	<b>Sheet</b> 3 of 12		<b>Rev</b> 1.2C

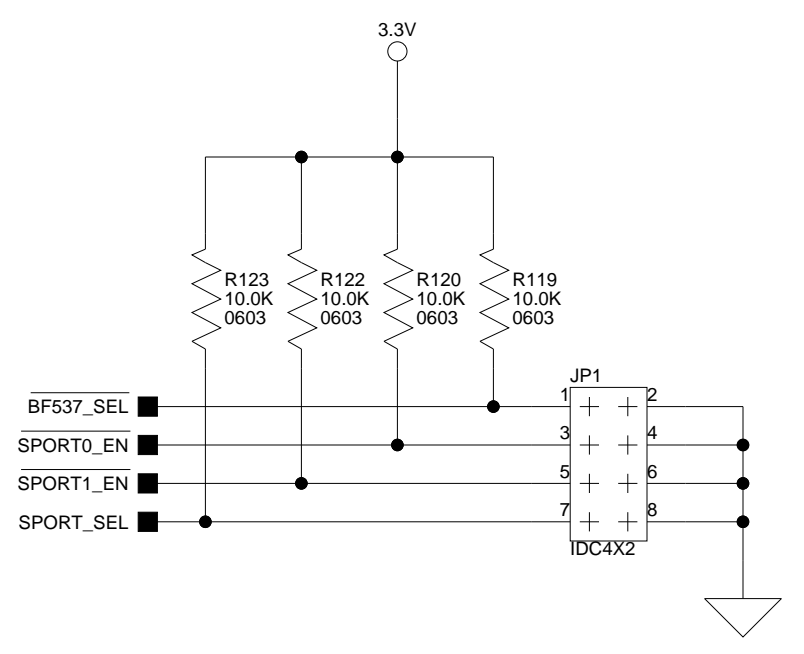
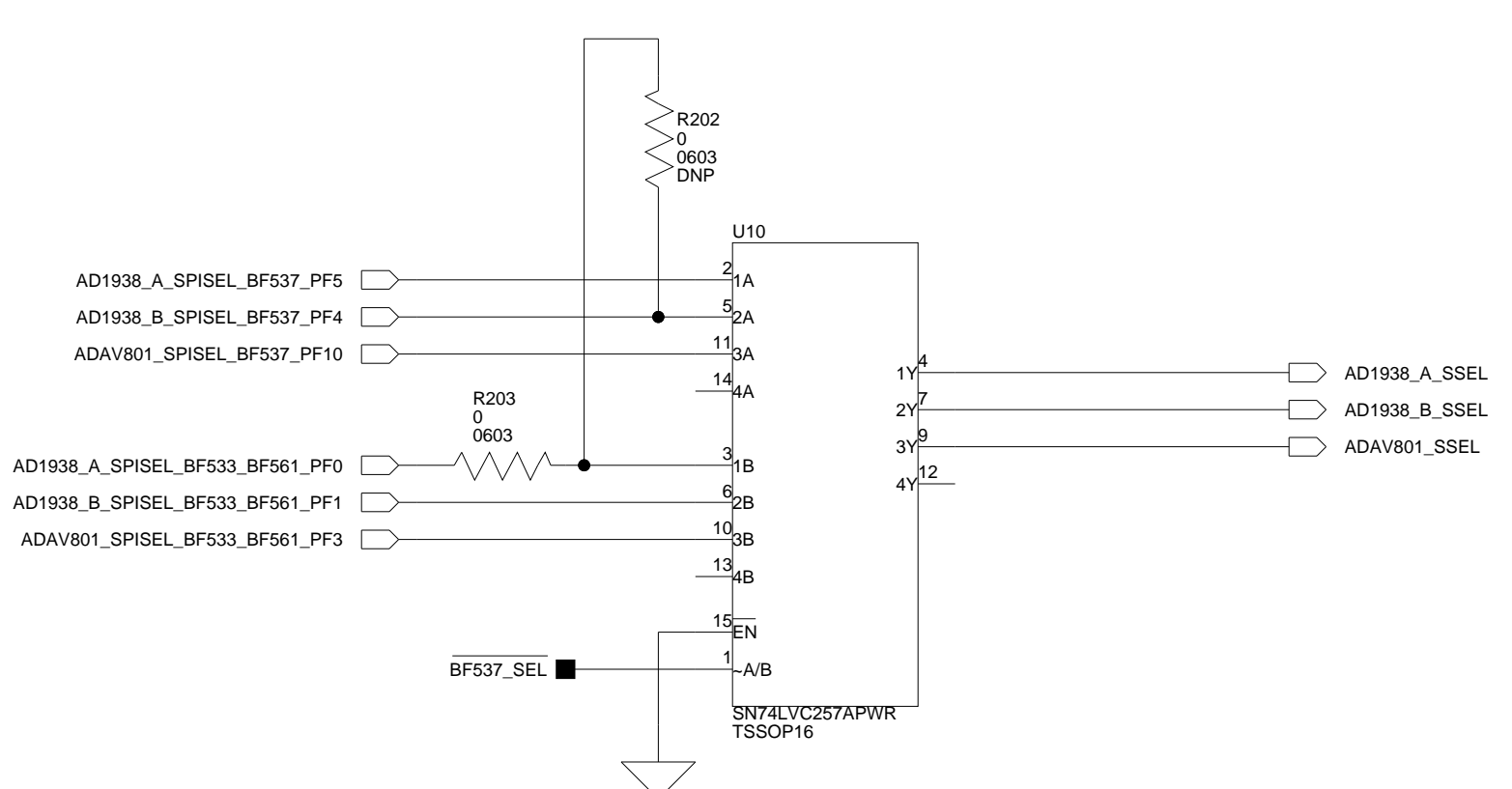
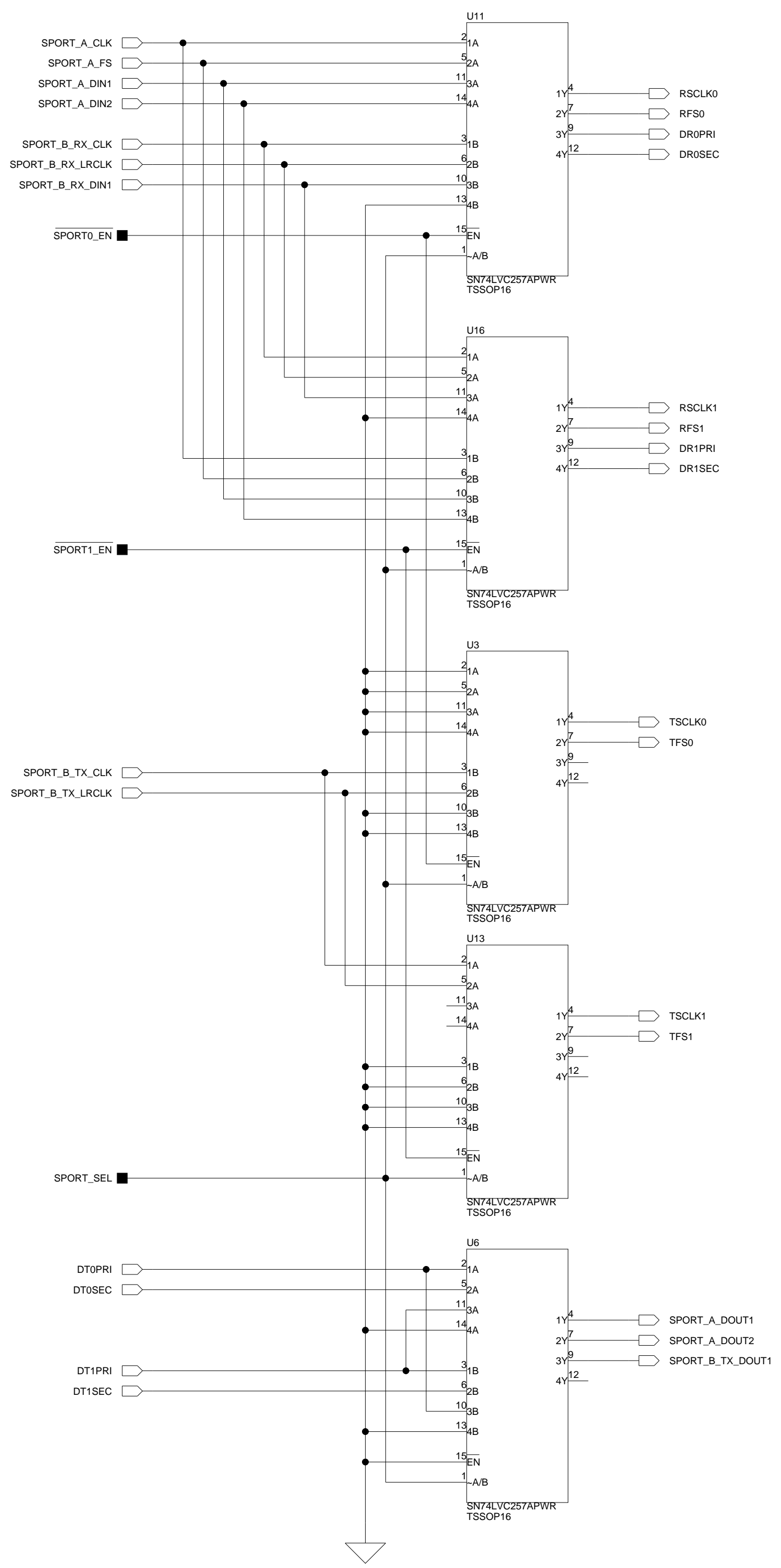

SPORT_SEL (JP1.7/8)	Connection
Not Installed	SPORT0 = SPORT_B (Digital) SPORT1 = SPORT_A (Analog)
Installed	SPORT0 = SPORT_A (Analog) SPORT1 = SPORT_B (Digital)

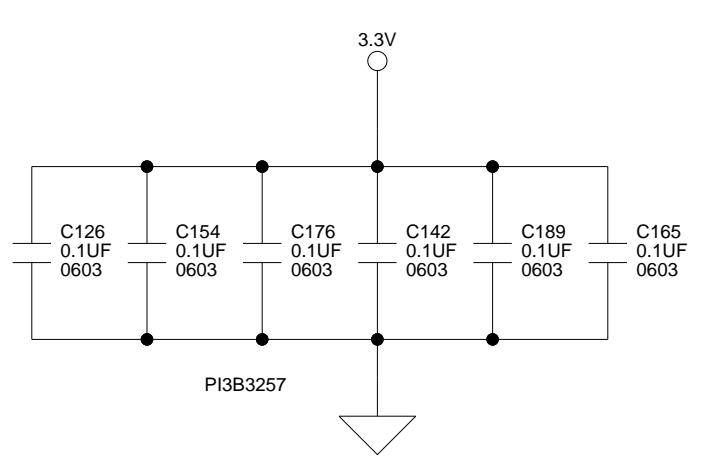

**ANALOG DEVICES**

20 Cotton Road  
Nashua, NH 03063  
PH: 1-800-ANALOGD

<b>Title</b> BLACKFIN AUDIO EZ-EXTENDER CONFIG		
<b>Size C</b>	<b>Board No.</b> A0195-2005	<b>Rev</b> 1.2C
<b>Date</b> 5-23-2007_11:47	<b>Sheet</b> 4 of 12	



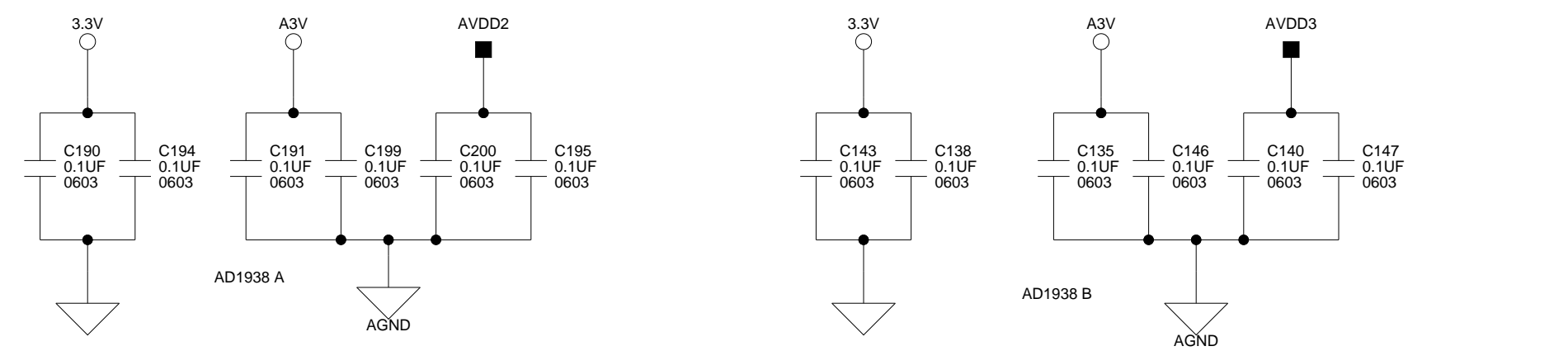
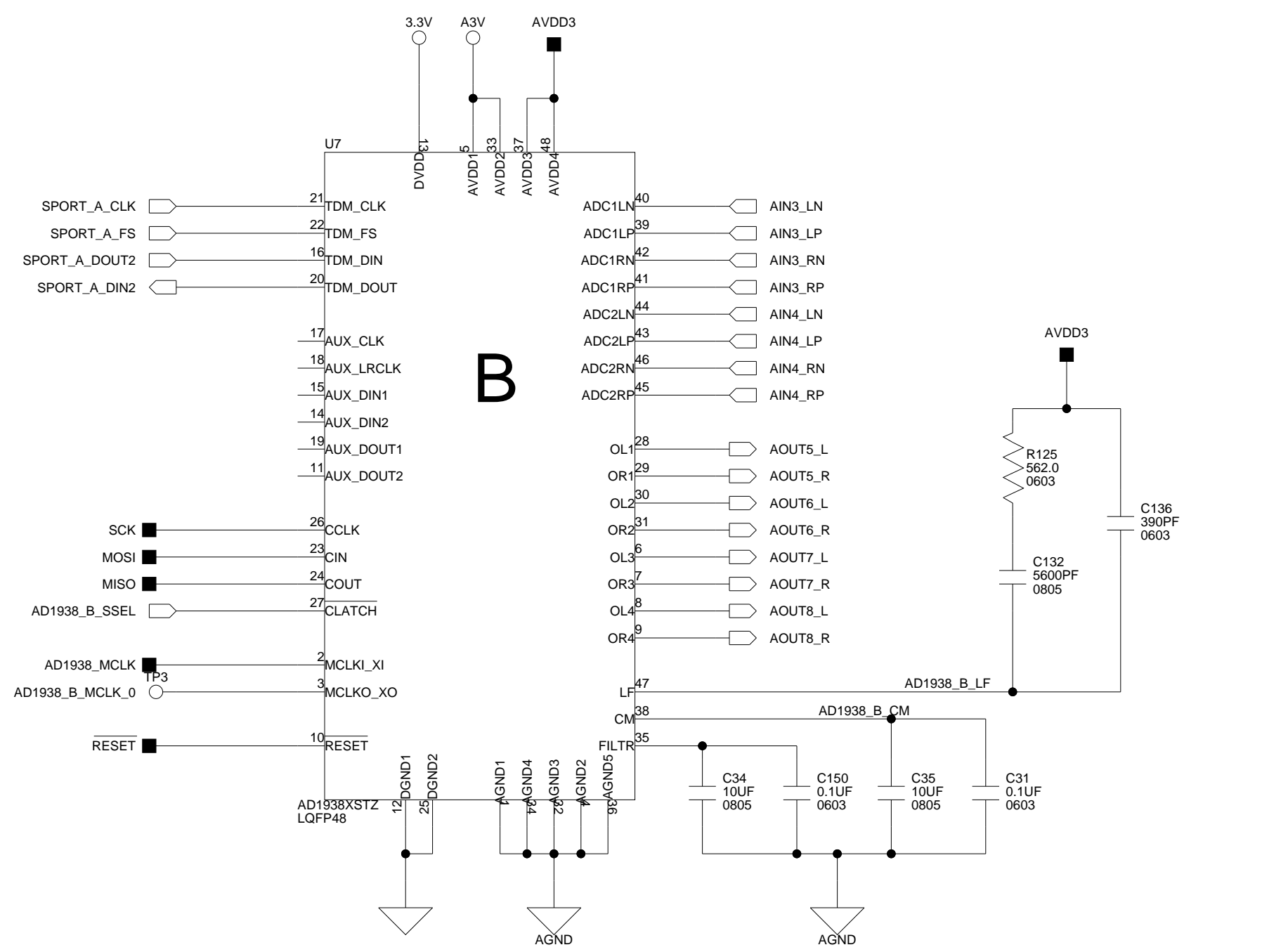
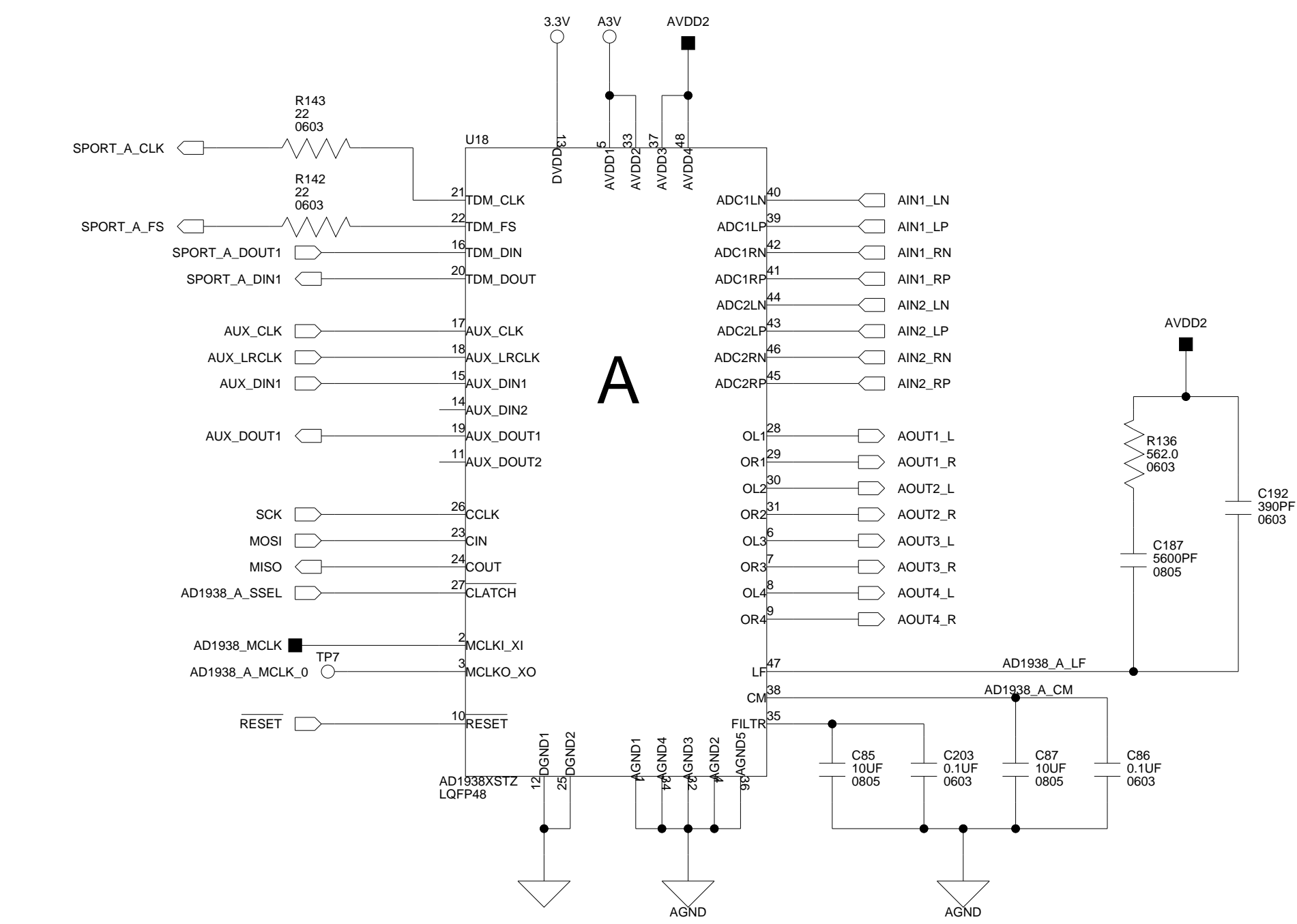
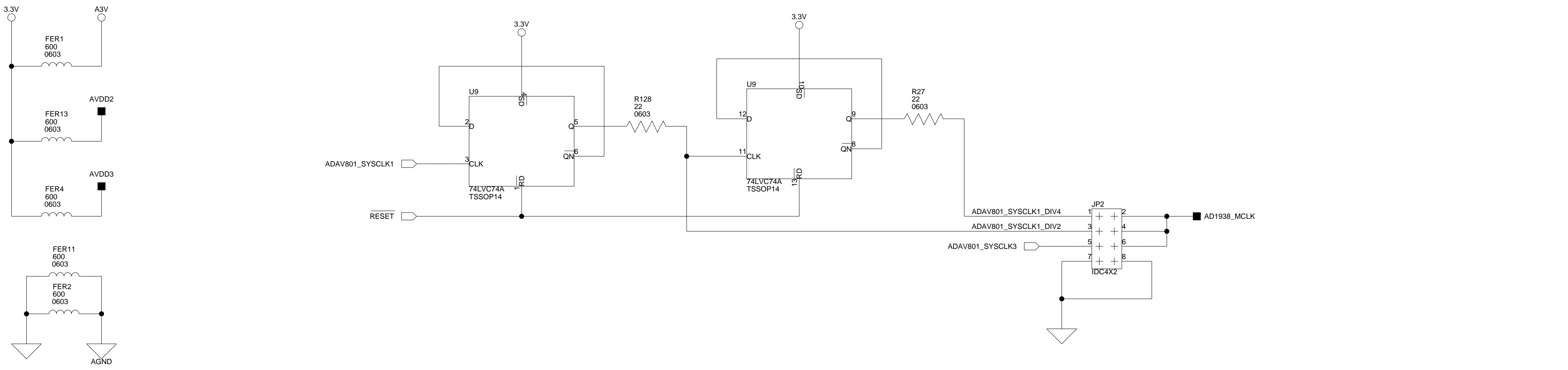

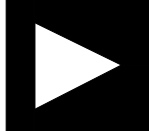
 <b>ANALOG DEVICES</b>		20 Cotton Road Nashua, NH 03063 PH: 1-800-ANALOGD	
		<b>Title</b> BLACKFIN AUDIO EZ-EXTENDER AD1938 - ANALOG AUDIO	
<b>Size</b> C	<b>Board No.</b> A0195-2005	<b>Rev</b> 1.2C	
<b>Date</b> 5-23-2007_11:47	<b>Sheet</b> 6 of 12		



A

B

C

D

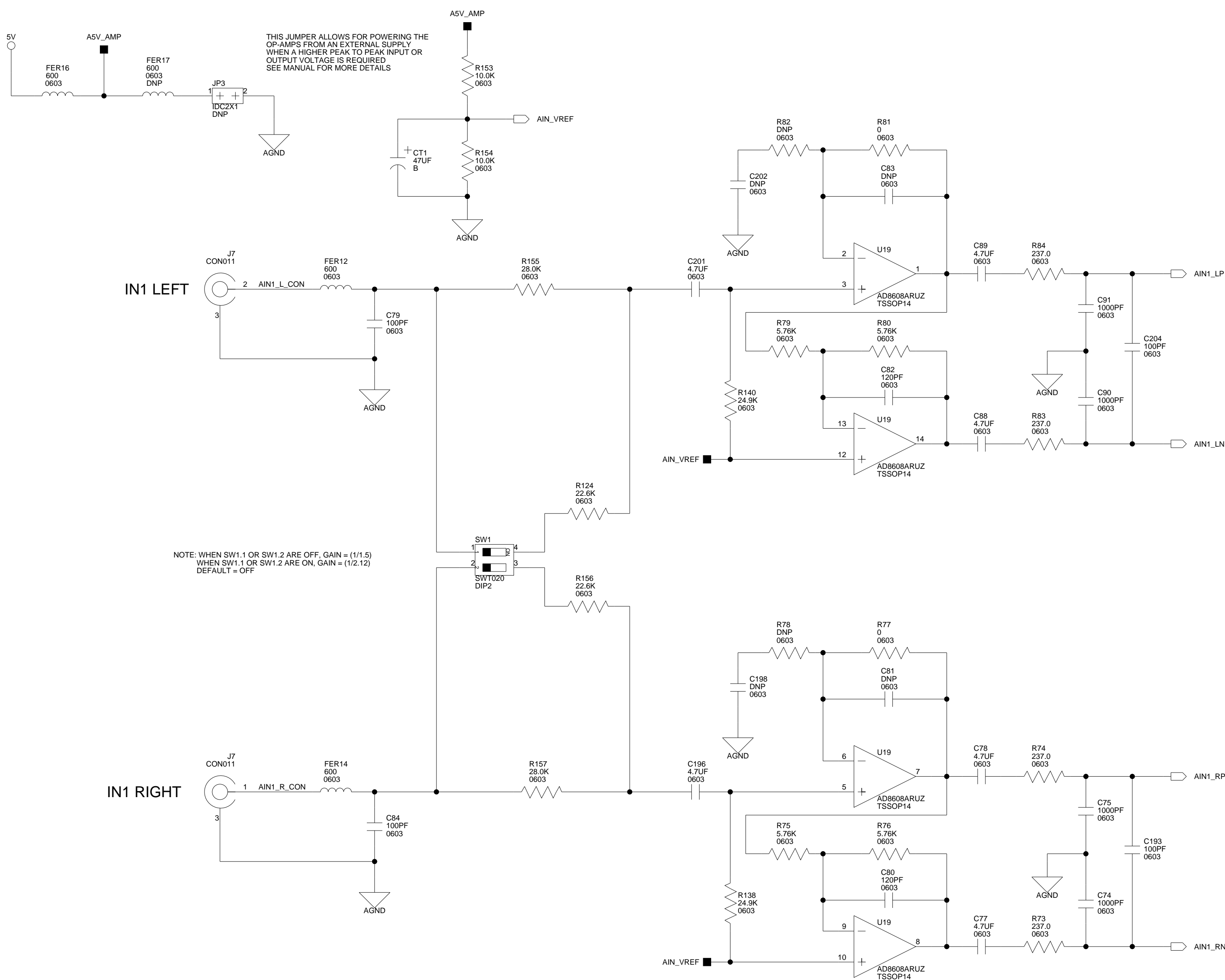

NOTE: WHEN SW1.1 OR SW1.2 ARE OFF, GAIN = (1/1.5)  
 WHEN SW1.1 OR SW1.2 ARE ON, GAIN = (1/2.12)  
 DEFAULT = OFF

ANALOG INPUT SIGNAL SPECS CAN BE FOUND IN THE MANUAL

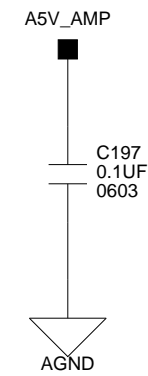

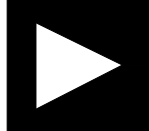
 <b>ANALOG DEVICES</b>		20 Cotton Road Nashua, NH 03063 PH: 1-800-ANALOGD	
		<b>Title</b> BLACKFIN AUDIO EZ-EXTENDER ANALOG IN 1	
<b>Size</b> C	<b>Board No.</b> A0195-2005	<b>Rev</b> 1.2C	
<b>Date</b> 5-23-2007_11:47	<b>Sheet</b> 7 of 12		

A

B

C

D

1

1

2

2

3

3

4

4

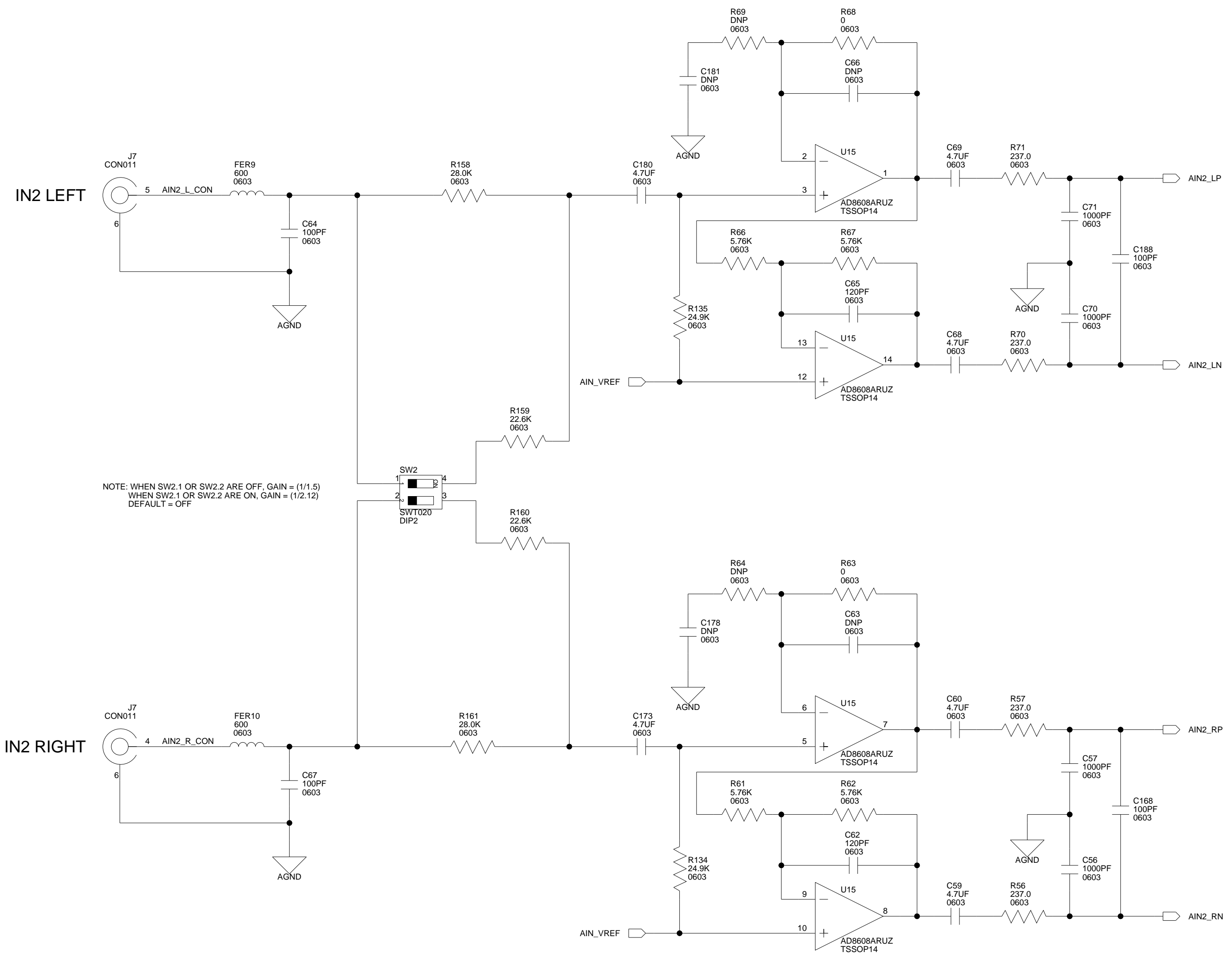

NOTE: WHEN SW2.1 OR SW2.2 ARE OFF, GAIN = (1/1.5)  
 WHEN SW2.1 OR SW2.2 ARE ON, GAIN = (1/2.12)  
 DEFAULT = OFF

ANALOG INPUT SIGNAL SPECS CAN BE FOUND IN THE MANUAL

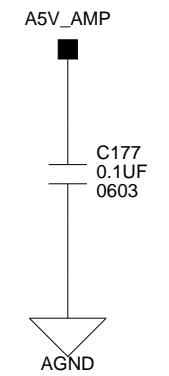

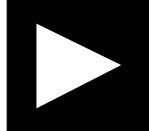
 <b>ANALOG DEVICES</b>		20 Cotton Road Nashua, NH 03063 PH: 1-800-ANALOGD	
		<b>Title</b> BLACKFIN AUDIO EZ-EXTENDER ANALOG IN 2	
<b>Size</b> C	<b>Board No.</b> A0195-2005	<b>Rev</b> 1.2C	
<b>Date</b> 5-23-2007_11:47	<b>Sheet</b> 8 of 12		

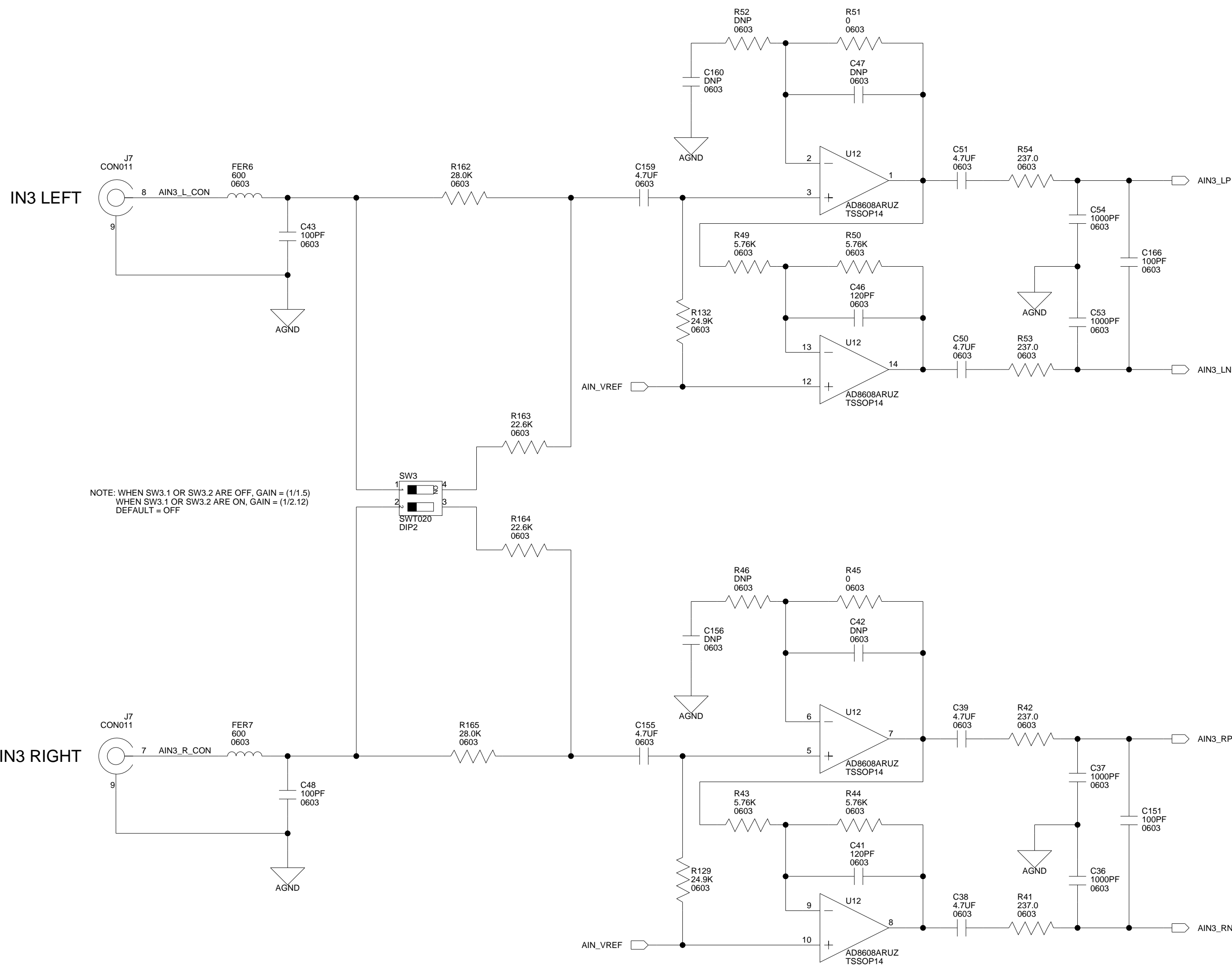

NOTE: WHEN SW3.1 OR SW3.2 ARE OFF, GAIN = (1/1.5)  
 WHEN SW3.1 OR SW3.2 ARE ON, GAIN = (1/2.12)  
 DEFAULT = OFF

ANALOG INPUT SIGNAL SPECS CAN BE FOUND IN THE MANUAL

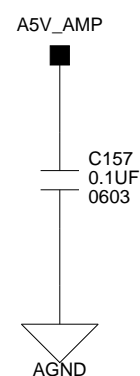

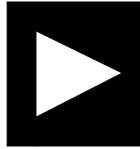
 <b>ANALOG DEVICES</b>		20 Cotton Road Nashua, NH 03063 PH: 1-800-ANALOGD	
		<b>Title</b> BLACKFIN AUDIO EZ-EXTENDER ANALOG IN 3	
<b>Size</b> C	<b>Board No.</b> A0195-2005	<b>Rev</b> 1.2C	
<b>Date</b> 5-23-2007_11:47	<b>Sheet</b> 9 of 12		

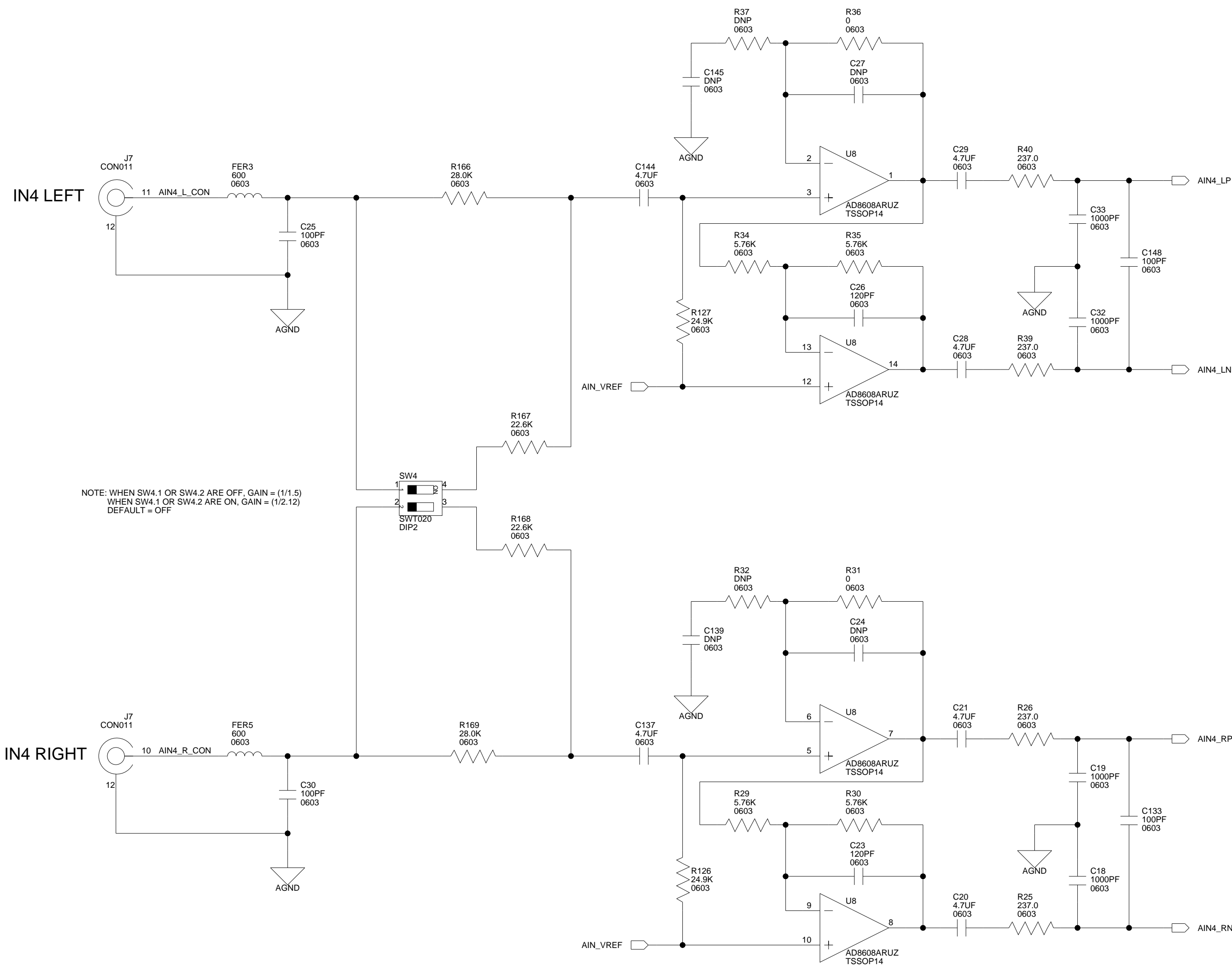

NOTE: WHEN SW4.1 OR SW4.2 ARE OFF, GAIN = (1/1.5)  
 WHEN SW4.1 OR SW4.2 ARE ON, GAIN = (1/2.12)  
 DEFAULT = OFF

ANALOG INPUT SIGNAL SPECS CAN BE FOUND IN THE MANUAL

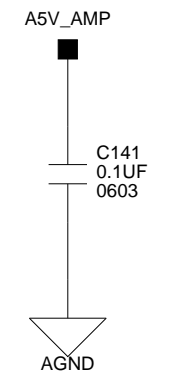

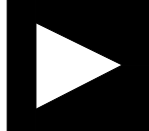
 <b>ANALOG DEVICES</b>		20 Cotton Road Nashua, NH 03063 PH: 1-800-ANALOGD	
		<b>Title</b> BLACKFIN AUDIO EZ-EXTENDER ANALOG IN 4	
<b>Size</b> C	<b>Board No.</b> A0195-2005	<b>Rev</b> 1.2C	
<b>Date</b> 5-23-2007_11:47	<b>Sheet</b> 10 of 12		

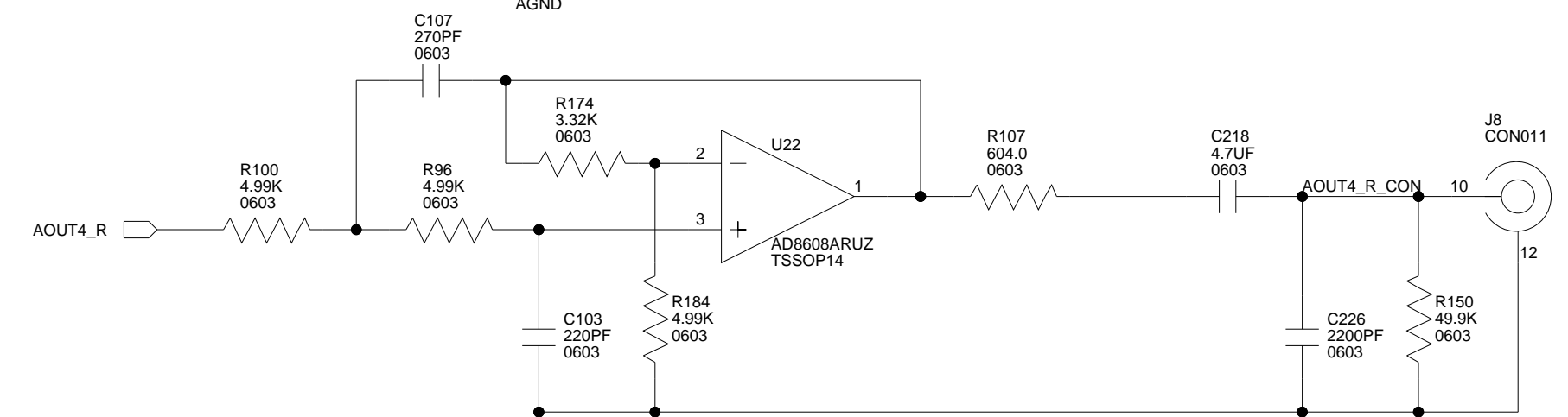
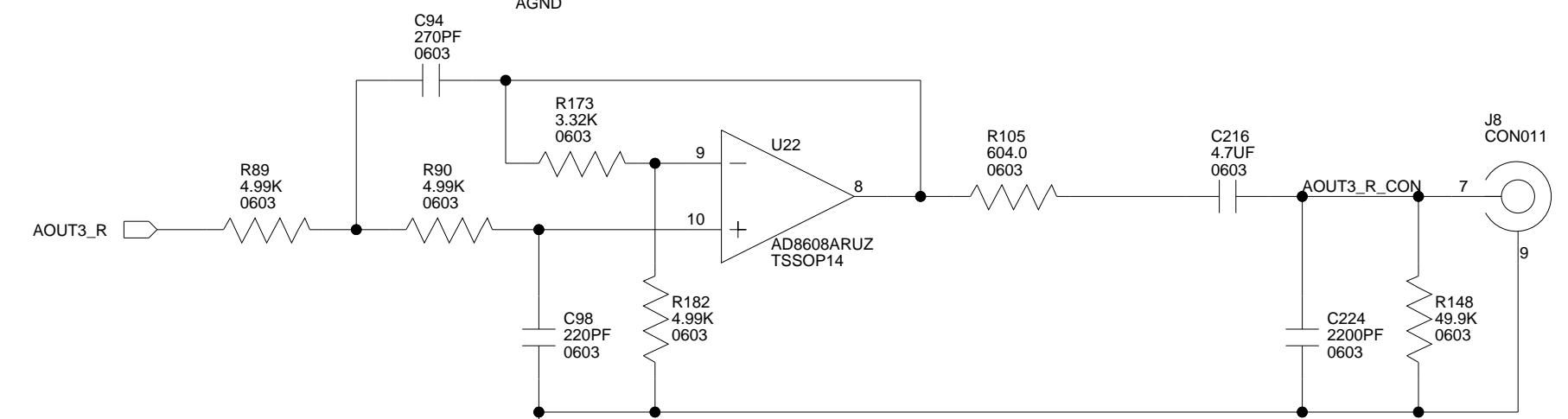
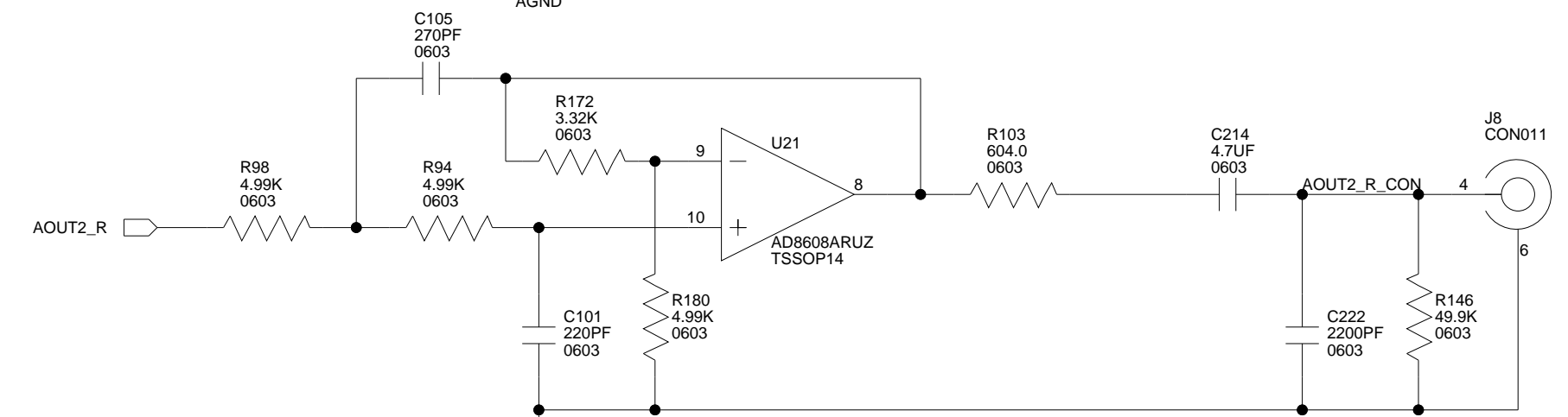
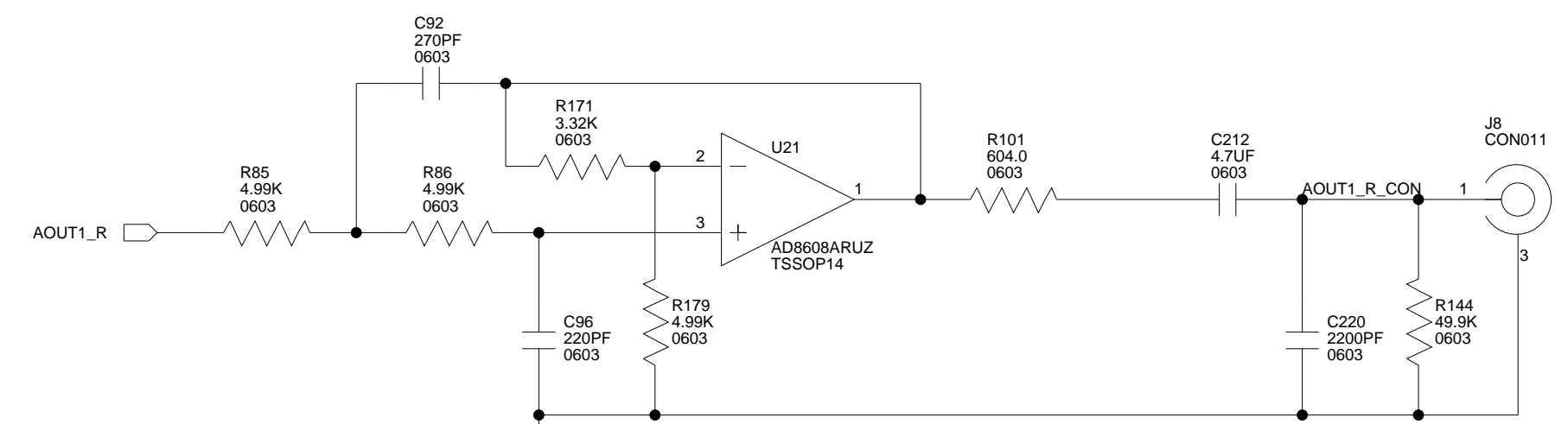
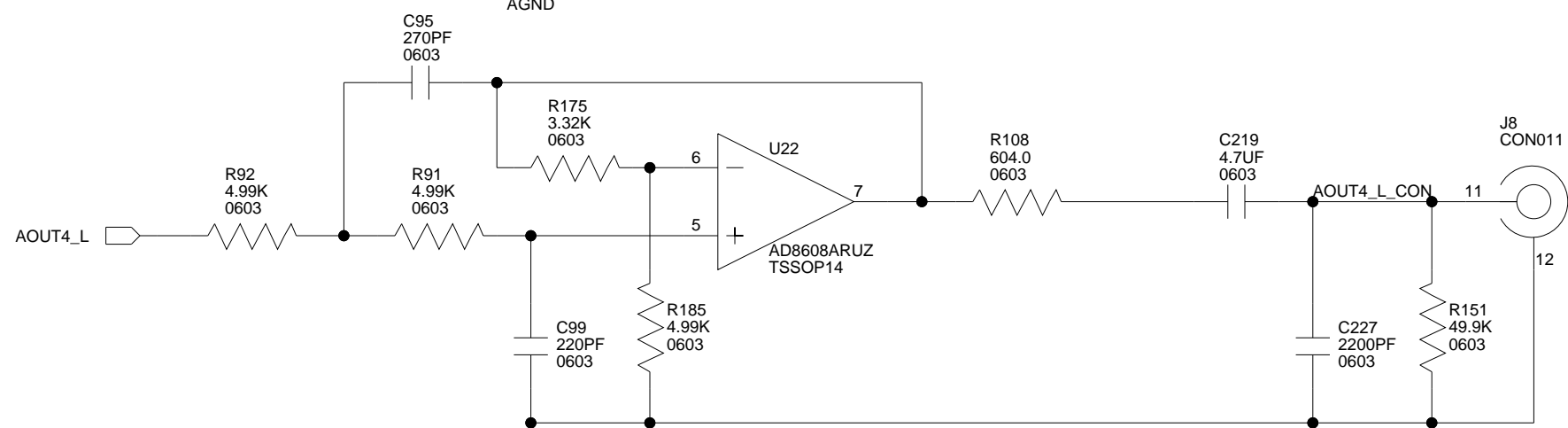
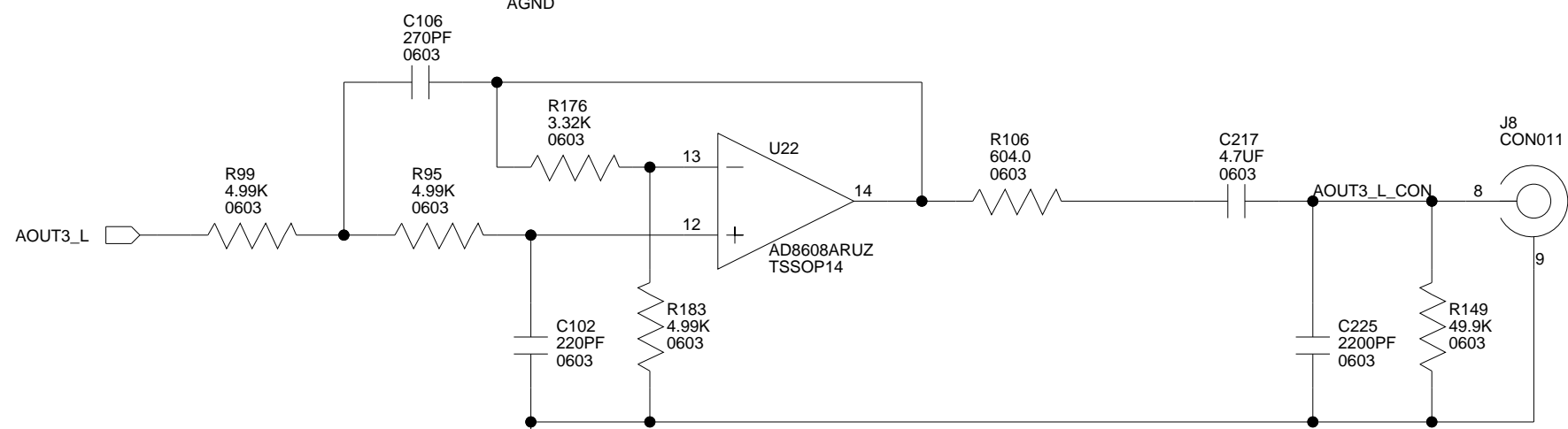
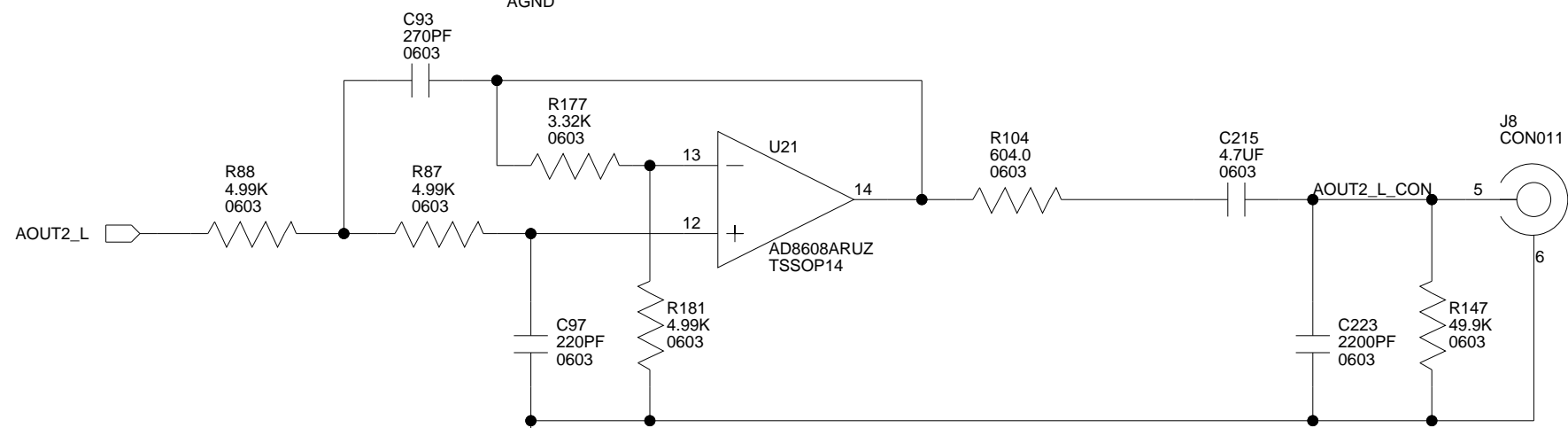
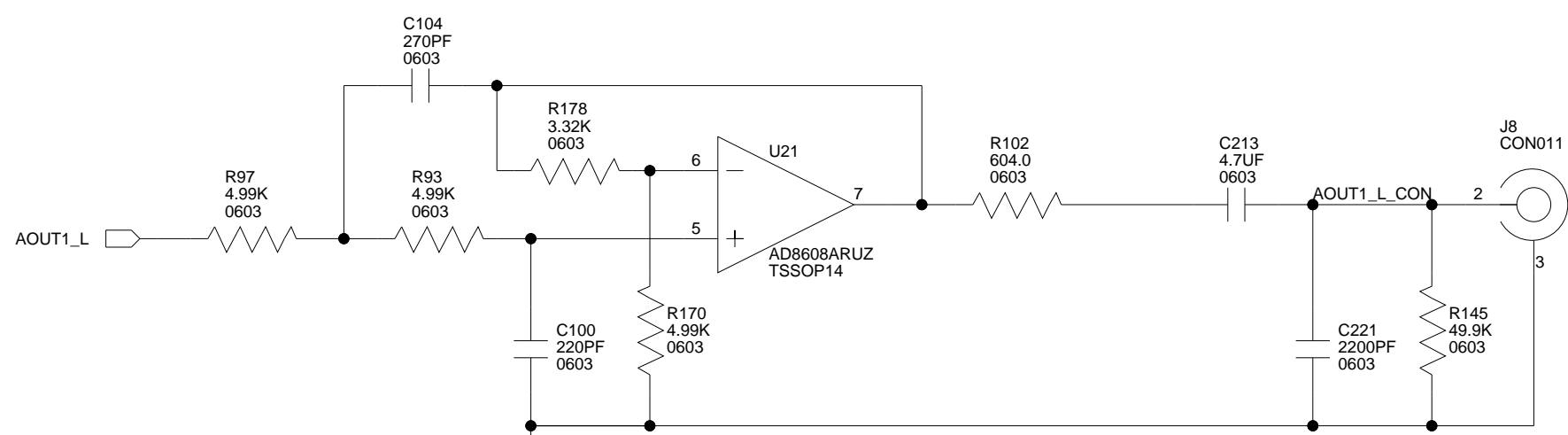

ANALOG OUTPUT SIGNAL SPECS CAN BE FOUND IN THE MANUAL

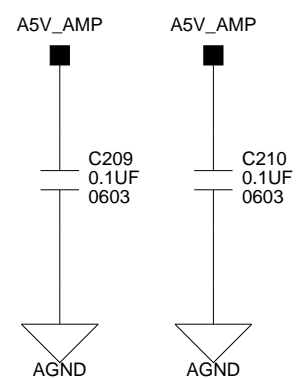

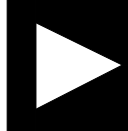
 <b>ANALOG DEVICES</b>		20 Cotton Road Nashua, NH 03063 PH: 1-800-ANALOGD	
		<b>Title</b> BLACKFIN AUDIO EZ-EXTENDER ANALOG OUT 1	
<b>Size C</b>	<b>Board No.</b>	A0195-2005	
<b>Date</b>	5-23-2007_11:47	<b>Sheet</b>	11 of 12
		<b>Rev</b>	1.2C

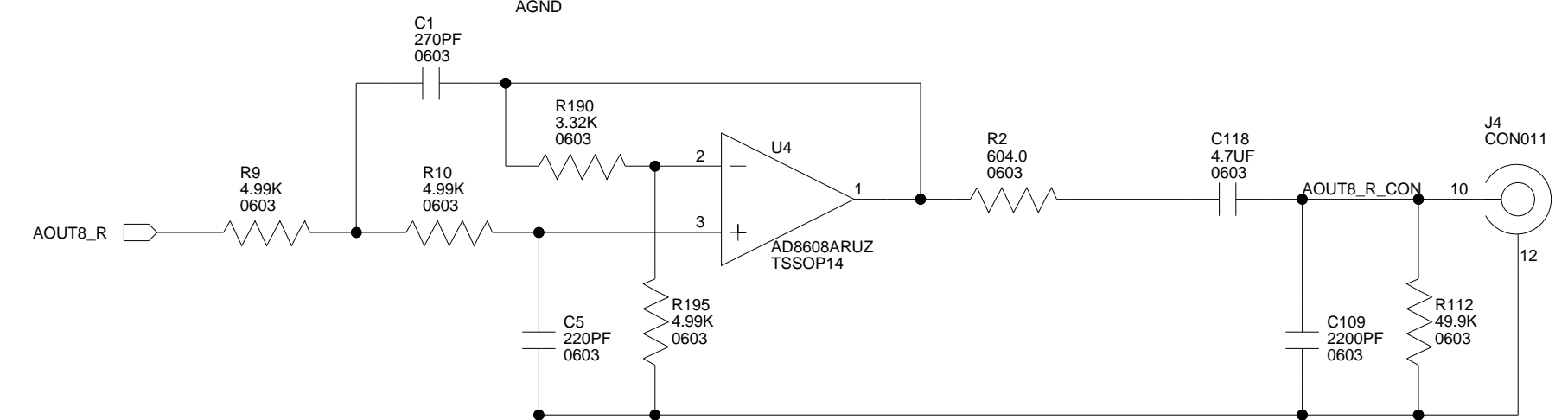
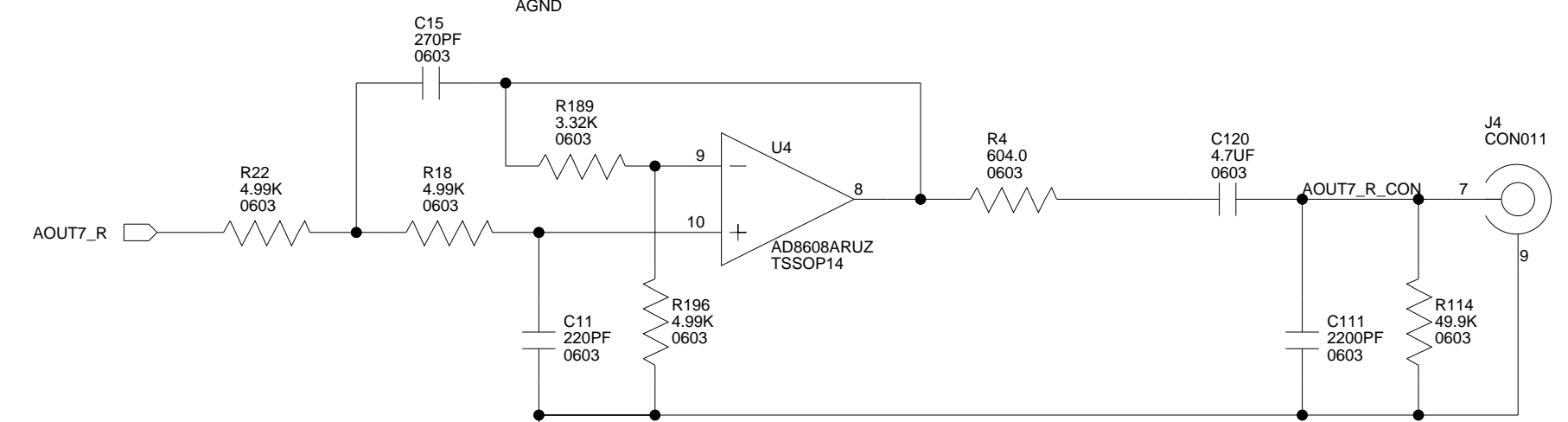
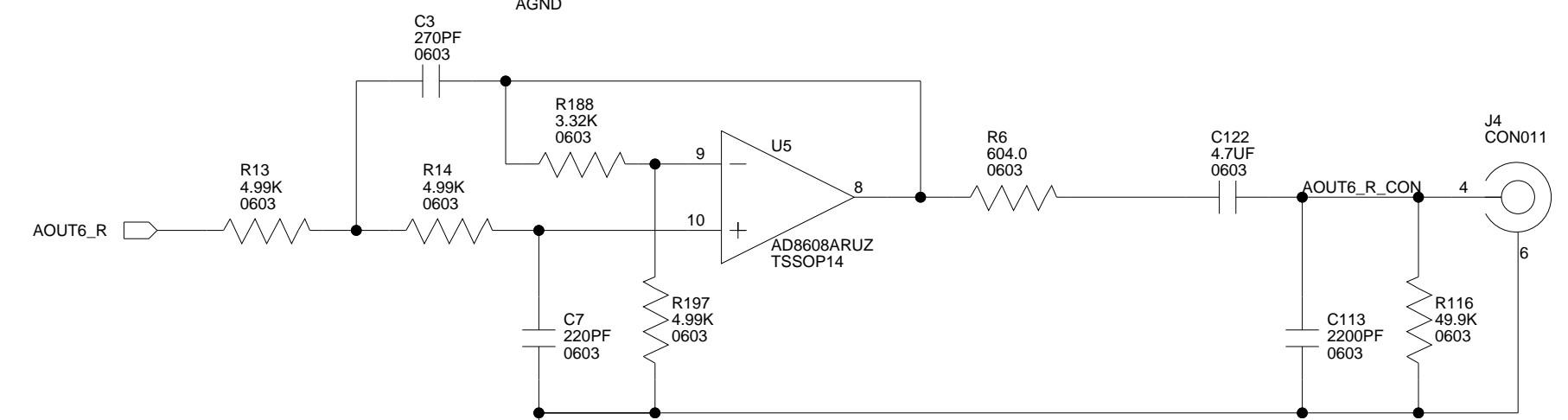
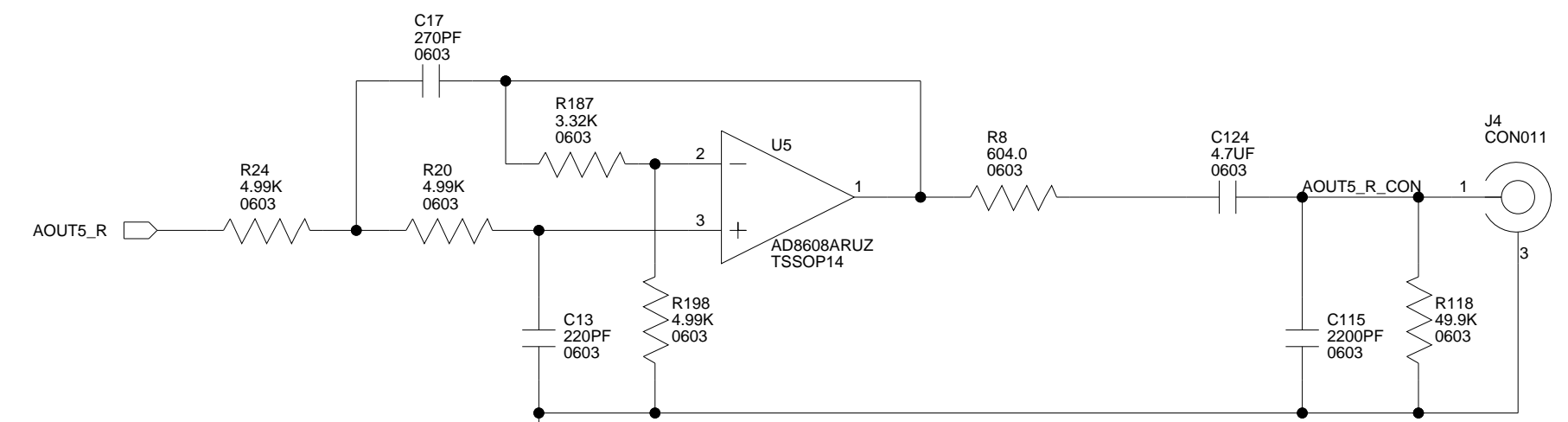
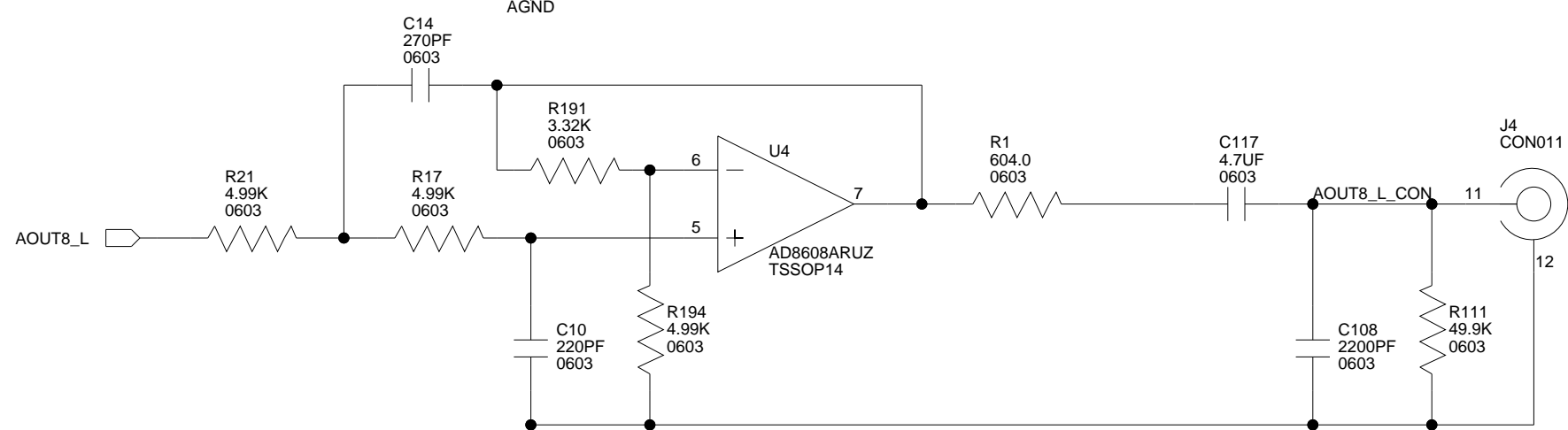
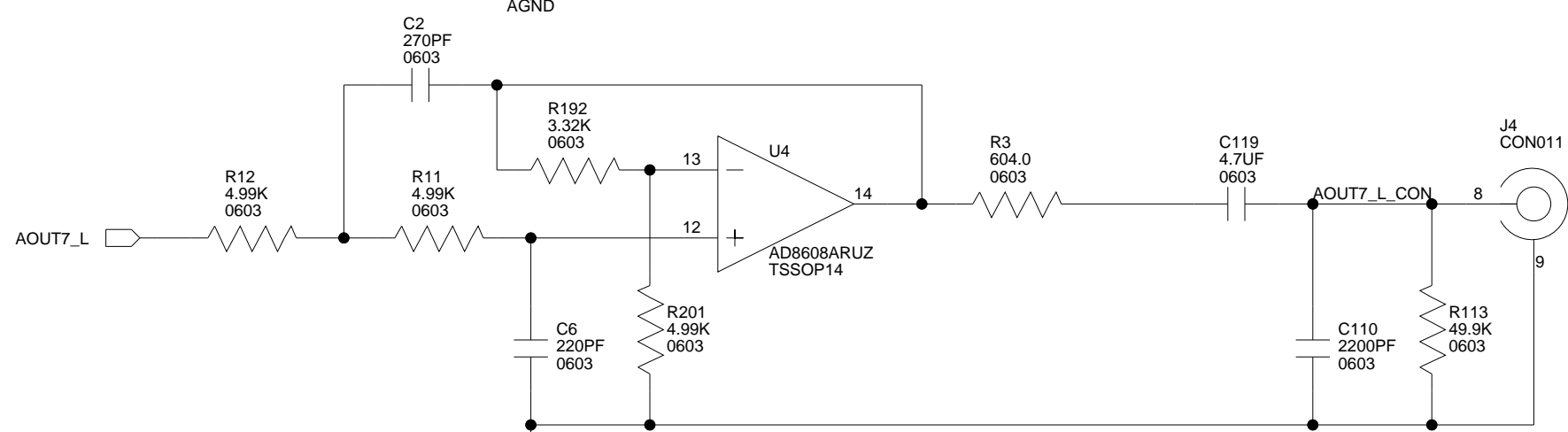
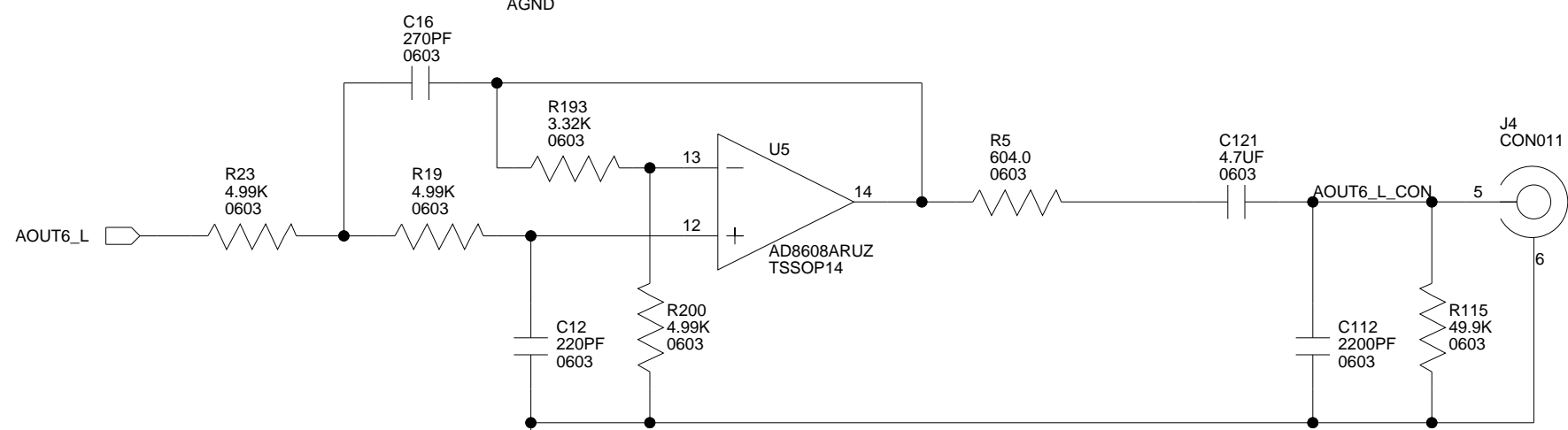
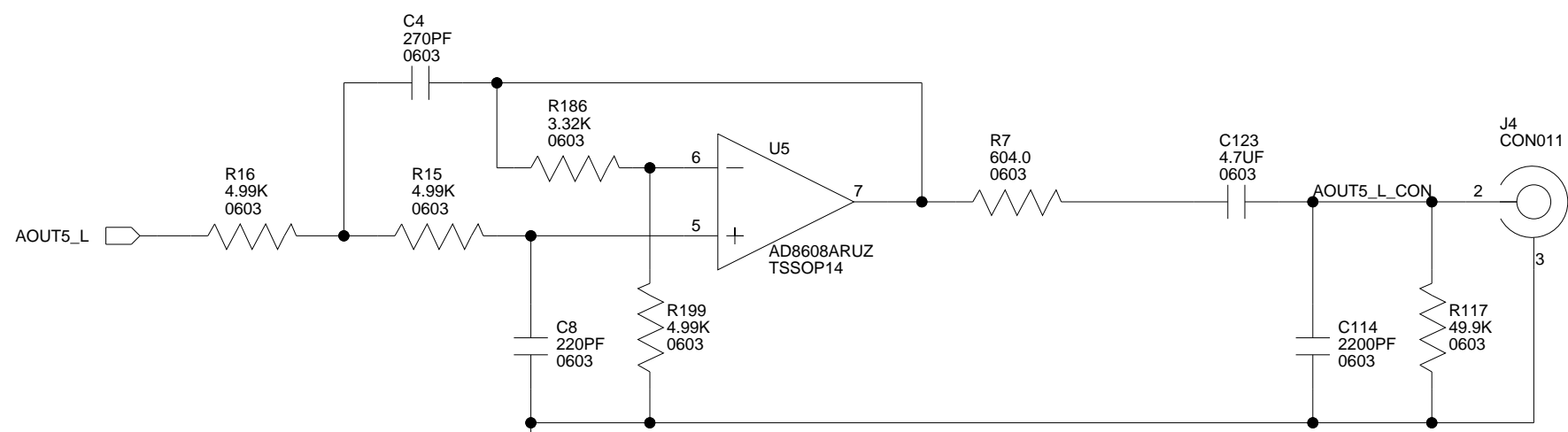

ANALOG OUTPUT SIGNAL SPECS CAN BE FOUND IN THE MANUAL

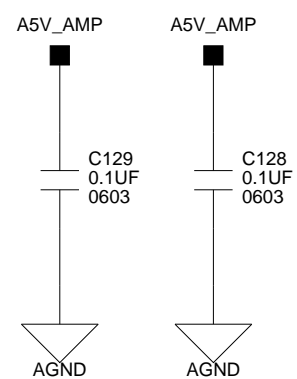

 <b>ANALOG DEVICES</b>		20 Cotton Road Nashua, NH 03063 PH: 1-800-ANALOGD	
		<b>Title</b> BLACKFIN AUDIO EZ-EXTENDER ANALOG OUT 2	
<b>Size C</b>	<b>Board No.</b> A0195-2005	<b>Rev</b> 1.2C	
<b>Date</b> 5-23-2007_11:47	<b>Sheet</b> 12 of 12		

# I INDEX

## A

AD1938 analog audio codecs, [-viii](#), [1-2](#), [1-4](#),  
[2-2](#), [2-6](#), [2-7](#)

MCLK source jumper (JP2), [2-6](#)

ADAV801 dual analog/digital audio codecs,  
[-viii](#), [1-3](#), [1-4](#), [2-2](#)

ADSP-BF537 EZ-KIT Lite select jumper  
(JP1.1/2), [2-5](#)

analog

audio data streams, [1-3](#), [2-2](#)

audio interface, [-viii](#), [1-2](#), [2-2](#)

input gain switches (SW1-4), [2-7](#)

input/output pins, [1-4](#)

stereo input/output, [1-4](#)

analog-to-digital converters (ADCs), [1-2](#)

architecture, of this Audio EZ-Extender, [2-2](#)

audio interfaces, *See* analog audio interface,  
digital audio interface

auxiliary serial ports, [1-3](#), [1-4](#)

## B

bill of materials, [A-1](#)

board

layout, [2-2](#)

schematic, [B-1](#)

## C

clock

frequencies, [1-3](#), [2-6](#)

signals, [1-3](#), [2-2](#)

configuration, of this Audio EZ-Extender, [1-1](#)

connectors, locations of, [2-2](#)

customer support, [-x](#)

## D

digital

audio data streams, [2-2](#)

audio interface, [-viii](#), [1-4](#), [2-2](#)

input channels, [1-3](#)

stereo input/output, [1-4](#)

digital-to-analog converters (DACs), [1-2](#)

## E

expansion interface, of EZ-KIT Lite, [-vii](#)

external

clocks, [1-4](#)

master clock (MCLK) signal, [1-3](#)

oscillators, [1-4](#)

EZ-KIT Lites

SPORT0 enable jumper (JP1.3/4), [2-6](#)

SPORT1 enable jumper (JP1.5/6), [2-6](#)

## F

frame sync signals, [1-3](#), [2-2](#)

## I

I2S mode, [1-4](#), [2-2](#)

input/output digital streams, [1-3](#)

# INDEX

## interfaces

- analog audio, [-viii](#)
- analog audio interface, [1-2](#)
- digital audio, [-viii](#), [1-4](#)

internal clocks, [1-4](#)

## J

### jumpers

- locations of, [2-2](#), [2-5](#)
- JP1.1/2 jumper (ADSP-BF537 EZ-KIT Lite select), [2-5](#)
- JP1.3/4 (EZ-KIT Lite SPORT0 enable), [2-6](#)
- JP1.5/6 (EZ-KIT Lite SPORT1 enable), [2-6](#)
- JP1.7/8 (SPORT select), [2-6](#)
- JP2 (MCLK source), [1-3](#), [2-6](#)
- JP4 (SPDIF loopback), [2-7](#)

## M

- master clock (MCLK), [2-6](#)
- MCLK source jumper (JP2), [2-6](#)
- multibit sigma-delta architecture, [1-2](#)

## N

notation conventions, [-xiii](#)

## P

- phase-locked loop (PLL), [1-3](#), [1-4](#)
- primary serial port, [1-5](#)
- product overview, [-vii](#)

## R

RCA jacks, [-viii](#), [1-4](#)

## S

- sample rates, [1-2](#), [1-4](#), [2-2](#), [2-6](#)
- schematic, [B-1](#)
- secondary serial port, [1-5](#)
- serial peripheral interface (SPI), [1-2](#), [1-4](#), [2-4](#)
  - select signals, [2-5](#)
- serial ports (SPORTs), [1-2](#), [1-3](#), [2-2](#)
  - select jumper (JP1.7/8), [2-6](#)
- setup, of this Audio EZ-Extender, [1-1](#)
- Sony Philips Digital Interface, *See* SPDIF
- SPDIF
  - input/output, [1-5](#)
  - loopback jumper (JP4), [2-7](#)
  - transceiver, [-viii](#)
- SPORT0 signals, [2-6](#)
- SPORT1 signals, [2-6](#)
- supported EZ-KIT Lites, [-xi](#)
- SW1-4 (analog input gain) switches, [2-7](#)
- SYSCLK1 pin, [1-3](#), [2-6](#)
- SYSCLK3 pin, [1-3](#), [1-5](#), [2-6](#)
- system architecture, [2-2](#)

## T

- time-division multiplexed (TDM) mode, [1-2](#), [2-2](#)
- TX/RX pins, [2-2](#)