

# herga



## Footswitches

SWITCHING AND SENSING SOLUTIONS



Herga Electric Limited is an independent UK manufacturer of switching systems. In addition to Footswitches, we offer other innovative switching solutions:-

<b>hergair</b>	Airswitching systems
<b>herga</b>	Pressure & Vacuum switches
<b>hergalite</b>	Fibre Optics / Infra red safety products
<b>herga</b>	Hand Controls

Our expertise spans the automotive, medical, packaging, domestic appliance and spa industries.

Herga is driven to respond rapidly to delight our customers. Herga seeks to develop its relations with customers to achieve their business goals.

### Global Presence

Our distributor network covering the world's major markets enables technical help and assistance to be just a phone call away.

### Continuous Improvement

Herga's approval to ISO 9002 ensures that we are fully in control of our quality. However, this is just the starting point for an aspiring World Class company. We encourage training and development and continuous improvements at individual, team and company level.

### How can we help you?

This brochure provides a brief overview of our product range. If you require further information, please contact us at our e-mail address:  
[herga.electric@dial.pipex.com](mailto:herga.electric@dial.pipex.com)

### Herga's customers worldwide include



### 6251 Heavy Duty Footswitch

This stylish, yet tough, industrial diecast footswitch can be supplied in a variety of colours, with or without a guard. It incorporates various switch options and is sealed to IP67 or IP68 upon request. Can be supplied with cordsets attached.



Page FS1 & 2

### 6252 Heavy Duty Footswitch

BG approved meets requirements of EN 60204 and EN 60947-5-1 with forced break contacts. This is a stylish, yet tough, industrial footswitch. The footswitch also incorporates various switch options and sealed to IP67 or IP68 upon request. Can be supplied with cordsets attached.



Page FS3 & 4

### 6253 Heavy Duty Foot Potentiometer

Combining a wide choice of colour combinations with standard 5K and 10K potentiometer switching. This footswitch can be sealed to IP67 or IP68 upon request. Herga can also offer advice or help with interfacing modules.



Page FS5 & 6

### 6255 'Mistral' Industrial Foot Air Valve

Utilising the stylish benefits of the industrial diecast footswitch offering a combination of pneumatic valves, 3/2 and 5/2 ports using the most advanced flow valves available. It is available in a variety of colours, with or without a guard.



Page FS7 & 8

### 6254 General Industrial Footswitch

Rigorous and tough diecast aluminium footswitch offering a wide variety of switching combinations with unlimited cordset options that can be sealed up to IP68 upon request. Foot guard options and colour options are available upon request.



Page FS9

### 6210 Light Industrial Footswitch

Tough all plastic lightweight construction footswitch offering a wide variety of switching combinations, it can be sealed up to IP68 upon request. Foot guard and colour options are available upon request.



Page FS10

### 6289 General Purpose Footswitch

Small and compact footswitch offering a vast variety of switching combinations with unlimited cordset options. It can be sealed up to IP68 upon request. A choice of foot guards and colour options are available upon request.

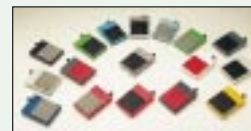

Page FS11 & 12

### 6220 and 6221 Leptron Palm/Footswitches

Innovative front hinged, low profile footswitch designed for improved user comfort. The Leptron all plastic switch is ideal for foot or palm use. Offering a vast variety of switching combinations with unlimited cordset options it can be supplied with a choice of foot guards for operator safety.



Page FS13 - 16

### Multi-Pedal Footswitches

Excellent for OEM applications where multi-switching combinations are required, these footswitches offer a wide variety of foot pedals in a variety of colour combinations and unlimited designs. These footswitches can be sealed up to IP68 upon request.



Page FS17 -18

### 6240 Footswitch Bellows

A neat and compact hand or foot operated switch made from tough flexible PVC double insulated with a wide choice of colours. Available with aluminium base plate for permanent fixing and offers contact and switching options. With foot guard option available.



Page FS19

### Your Guide to Certification Markings

Covers most worldwide authorities/certification marks.



Page FS20

### Your Guide to IP Ratings

Sealing of electrical enclosures.

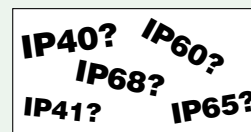

Page FS21

### Your Guide to Standards and Comparisons of Wire Size and Ratings with Fax back form and sketch pad.



Page FS22

# 6251 ~ Heavy Duty Footswitch



### Benefits

- ❖ Average life expectancy 1x10<sup>6</sup> operations
- ❖ Rugged high performing heavy duty footswitch
- ❖ Waterproof to IP67, IP68 upon request
- ❖ Choice of colours
- ❖ Distinctive styling
- ❖ Screw terminals and self-lifting clamp for connection of flexible leads 2 x 1.5mm<sup>2</sup> or wire up to 2 x 2.5mm<sup>2</sup>
- ❖ Available in your own livery for a small cost
- ❖ Competitively priced for OEM users

### Guard Option

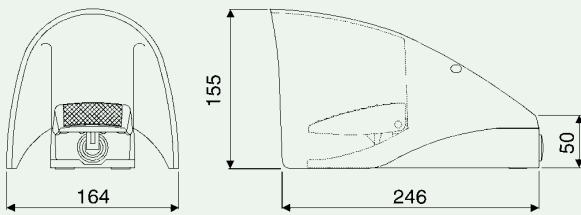

### Cover Option

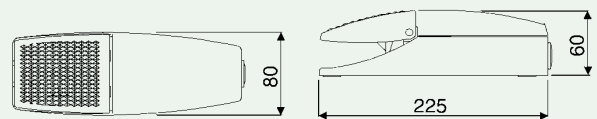

6251 - [ ] [ ] [ ] A - [ ] [ ] Z 0

#### 1. Model Number

#### 2. Cover and Guard Colours

- |                  |                  |
|------------------|------------------|
| A Cover - Yellow | B Guard - Yellow |
| C Cover - White  | D Guard - White  |
| E Cover - Blue   | F Guard - Blue   |
| G Cover - Orange | H Guard - Orange |
| M Cover - Red    | N Guard - Red    |

#### 3. Base Colour

- |         |         |               |
|---------|---------|---------------|
| A Black | B White | C Silver Grey |
|---------|---------|---------------|

#### 4. Threading / Hole Information

- A Single Back Entry 20mm
- B Single Back Entry PG 13.5 Gland Thread
- C Double Side Entry 20mm Gland Thread
- D Double Side Entry PG 13.5 Gland Thread

#### 5. Tread Colour

- A Black

#### 6. Action - First letter denotes the action, second letter denotes the electrical rating in section 7 (please note the choice of action dictates the electrical rating)

- AA Momentary, Slow Make and Break
- BB Momentary, Snap Action Make and Break
- CB Alternate Action, Snap Action Make and Break
- DB Momentary, 2 Pole Snap Action Make and Break
- EA Momentary, 2 Pole Slow Make and Break
- F Double Pole, Double Action, V3 Single Break, Snap Action
- G Double Pole, Double Throw, V3 Single Break, Snap Action

**Note:** For options F and G please select E, F or G below only

#### 7. Electrical Rating

- A Slow Make and Break 380V 10A 500V 6A
- B Snap Action 380V 10A 500V 6A
- E V3 Silver Contacts C/Over (3 Off 6.3mm Amp Tags) 21A 250V ac
- F V3 Gold Contacts C/Over (3 Off 6.3mm Amp Tags) 0.1A 250V ac
- G V3 Silver Contacts C/Over (3 Off 6.3mm Amp Tags) 25A 277V ac

#### 8. Emergency Stop

- Z No Emergency stop fitted

# 6251 ~ Heavy Duty Footswitch



Design	To EN 60204-1			
IP Rating	The electrical housing has an environmental rating of IP67 (IP68 upon request)			
Approvals	Switches to EN 61058			
Rated Operational Voltage	500V ac, over 380V ac same potential only			
Rated Operational Current	10A	380V	AC1	
	10A	110V	AC1	
	6A	500V	AC1	
	6A	250V	AC11	
	6A	110V	AC11	
	<b>Note:</b> When the footswitch is supplied with a pre-wired cordset the cordset rating will take precedence over the footswitch rating. The rating will be marked somewhere on the cordset.			
Contact Configuration	Normally open / normally closed			
Contact Gap	>3mm suitable for mains isolation			
Temperature Operating Range	-25°C to +60°C			
Mechanical Endurance	1x10 <sup>6</sup> operations			
Electrical Life Expectancy At Category AC-15	0.5 x 10 <sup>6</sup> switching cycles when interrupting AC-11 6A at 250V			
Terminals	Screw terminals with self-lifting clamps for connection of flexible leads Minimum 2 x 1.5mm <sup>2</sup> Standard Conductor Maximum 2 x 2.5mm <sup>2</sup> Standard Conductor			
Action Type from Order Code	A	B	C	D
Connection Diagram	1 Pole Slow Make Slow Break	1 Pole Snap Action	2 Pole Snap Action	2 Pole Slow Make Slow Break
Limit Switches (Other switching sequences are available upon request)				

### MICROSWITCHES 21A

Average Life Expectancy	Mechanical	1.0 x 10 <sup>6</sup>		
	Electrical	2.0 x 10 <sup>5</sup> @ 10A	1.0 x 10 <sup>4</sup> @ 21A	
		Max. Electrical Load		
	Voltage	Resistive	Inductive	Motor (Pf0.75)
AC	250V	21A	8A	2HP
	250V	21A		1HP
	125V	21A		
DC	6V	21A	21A	
	12V	15A	15A	
	24V	8A	7A	
	60V	1A	0.5A	
	110V	0.5A	0.2A	
	220V	0.25A	0.1A	

### GOLD CONTACT MICROSWITCHES

Average Life Expectancy	Mechanical	1.0 x 10 <sup>6</sup>		
	Electrical	2.0 x 10 <sup>5</sup> @ .01A		
		Max. Electrical Load		
	Voltage	Resistive	Inductive	Motor (Pf0.75)
AC	250V	0.1A	0.05	N/A
UL/CSA Only	125V	0.1A	---	---
Notes: Dry Switching These switches must be used for low power circuits i.e. low current (4 to 100 milliamperes) and low voltage (below 30V), consult herga for further advice.				

### MICROSWITCHES 25A

Average Life Expectancy	Mechanical	1.0 x 10 <sup>6</sup>		
	Electrical	1.0 x 10 <sup>5</sup> @ 1.0A		
		Max. Electrical Load		
	Voltage	Resistive	Inductive	Motor (Pf0.75)
AC	277V	25A		2HP
	250V	25A		2HP
UL/CSA Only	125V	25A		1HP

In all applications except where protective extra low voltage (PELV) circuits are being switched, an earth conductor must be installed. The earth conductor should be rated in accordance with the prevailing standards.

Microswitch Standards: EN 60730 EN 61058 and UL 508  
Microswitch Approvals: CE, BEAB, CSA, DEMCO, IMQ, KEMA, NEMCO, OVE, SEMCO, SETI, SEV, UL, VDE



# 6252 ~ Heavy Duty Footswitch



Design	To EN 60204-1 with switching to meet EN 60947-5-1. VDE 0660 part 200, IEC 947-5-1				
IP Rating	The electrical housing has an environmental rating of IP67 (IP68 upon request)				
Rated Operational Voltage	500V ac, over 380V ac same potential only				
Rated Operational Current	AC (40 to 60hz)			DC	
	<u>I<sub>e</sub>/AC-12</u>	<u>U<sub>e</sub>/e</u>	<u>Ac-15</u>	<u>U<sub>e</sub>/e</u>	<u>DC-12</u>
	10	24	10	24	10
	10	125	10	48	6
	10	230	6	110	4
	10	400	4	220	1
	10	500	3	440	0.5
	<b>Note:</b> When the footswitch is supplied with a pre-wired cordset, the cordset rating will take precedence over the footswitch rating. The rating will be marked on the cordset.				
Contact Configuration	Normally open + normally closed positive opening operation to EN 60947-5-1				
Contact Gap	>3mm suitable for mains isolation				
Temperature Operating Range	-25°C to +60°C				
Mechanical Endurance	1x10 <sup>6</sup> operations				
Electrical Life Expectancy At Category AC-15	0.5 x 10 <sup>6</sup> switching cycles when interrupting AC-15 6A at 250V				
Terminals	Screw terminals with self-lifting clamps for connection of flexible leads Minimum 2 x 1.5mm <sup>2</sup> Standard Conductor Maximum 2 x 2.5mm <sup>2</sup> Standard Conductor				
Action Type from Order Code (Action Option)	A	B	D	E	F
Connection Diagram	1 Pole Slow Make Slow Break	1 Pole Snap Action	2 Pole Snap Action	2 Pole Slow make Slow Break	Double Action Snap Action
Limit Switches					

In all applications, except where protective extra low voltage (PELV) circuits are being switched, an earth conductor must be installed. The earth conductor should be rated in accordance with the prevailing standards.

### Cordsets

The BIA approval can also include your selected, factory fitted, cordset choice. The cordset will not be BIA approved, although the footswitch will remain BIA approved.



BIA 964025 refers to products:

- 6252-XXXX-AAZ0
- 6252-XXXX-BBZ0
- 6252-XXXX-DBZ0
- 6252-XXXX-DAZ0



BIA 964026 refers to product:

- 6252-XXXX-MBZ0





# 6253 ~ Heavy Duty Foot Potentiometer



Initial depression of the foot pedal causes both microswitch contacts to change state and further depression creates a resistance change in the potentiometer.

## ELECTRICAL SWITCHES

Average Life Expectancy	Mechanical	1.0 x 10 <sup>6</sup> Operations		
	Electrical	2.0 x 10 <sup>5</sup> @ 10A	1.0 x 10 <sup>5</sup> @ 21A	
Max. Electrical Load				
	Voltage	Resistive	Inductive	Motor (Pf0.75)
AC	250V	21A	8A	
	250V	21A		2HP
	125V	21A		1HP
DC	6V	21A	21A	
	12V	15A	15A	
	24V	8A	7A	
	60V	1A	0.5A	
	110V	0.5A	0.2A	
	220V	0.25A	0.1A	

## POTENTIOMETER

<b>Electrical Data</b>	5.0k Ω	10.0k Ω
Resistance Tolerance	±20%	±20%
Linearity	±1.0%	±1.0%
Recommended Wiper Current	<0.1 μ A	<0.1 μ A
Power Rating	0.5W/40°C	0.5W/40°C
Max Wiper Fault Current	10mA	10mA
Max Potentiometer Rating	50V	70V
Dielectric Strength	1000V ac	1000V ac
Resistance	Conductive Plastic	
<b>Mechanical Data</b>		
Average Life Expectancy Cycles	5.0 x 10 <sup>6</sup>	5.0 x 10 <sup>6</sup>

Microswitch Approvals: CE, BEAB, CSA, DEMCO, IMQ, KEMA, NEMCO, OVE, SEMCO, SETI, SEV, UL and VDE

Microswitch Standards: EN 60730 EN 61058 and UL 508

**Notes:** Dry Switching: If switching low power circuits i.e. low current ( 4 to 100 milliamperes) and low voltage (below 30V), please consult herga for advice

IP Rating: The electrical housing has an environmental rating of IP67 (IP68 upon request)

## RECOMMENDED SCHEMATIC

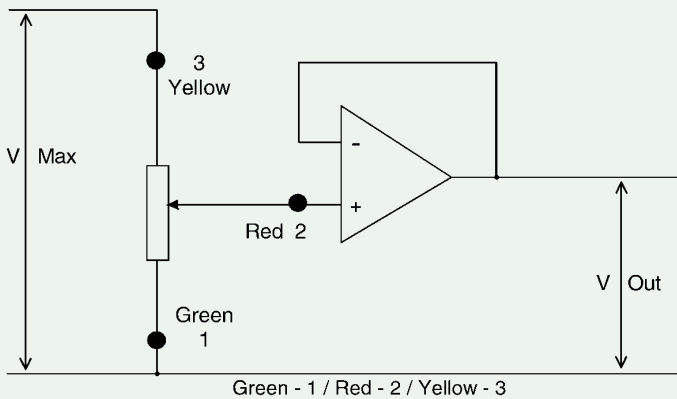

## DE-RATING CURVE

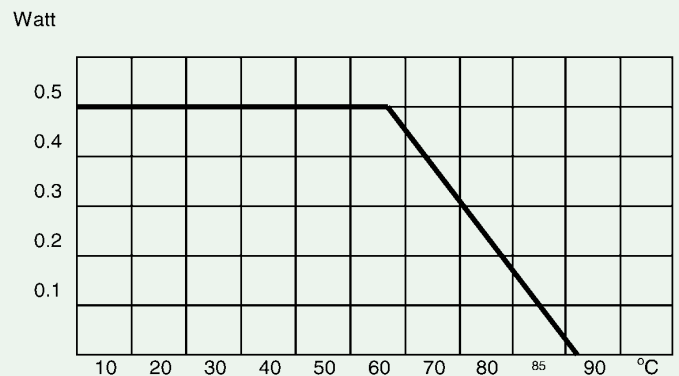

In all applications except where protective extra low voltage (PELV) circuits are being switched, an earth conductor must be installed. The earth conductor should be rated in accordance with the prevailing standards.

❖ Other potentiometer resistance values from 1K Ohm to 10K Ohm can be supplied in medium batch volumes, although these versions cannot be supplied with microswitch contacts.

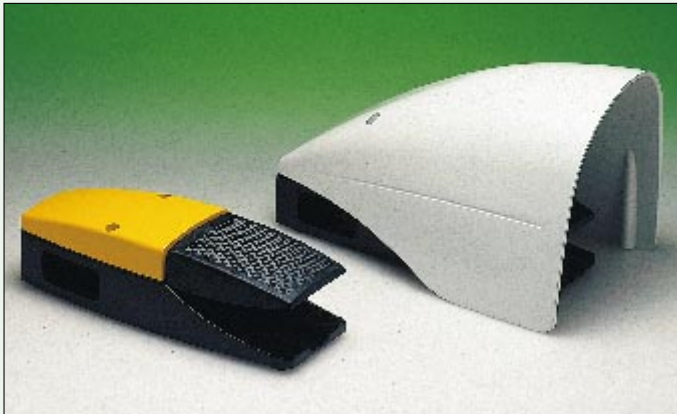

**Benefits**

- ❖ The Mistral heavy industrial foot air valve offers high performance and style
- ❖ Available in a choice of colour combinations and valve options including valve port threads
- ❖ Special colours available for volume OEM customers
- ❖ Robust construction from die-cast aluminium
- ❖ The guard is large enough to allow the operator to wear industrial protective shoes
- ❖ Competitively priced for OEM users
- ❖ Mechanical performance 10<sup>6</sup>+ operations

Guard Option

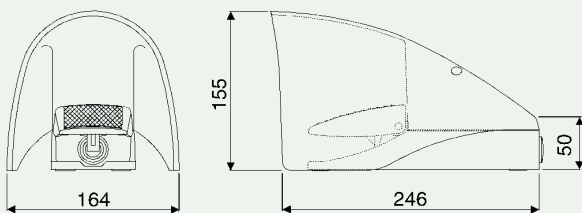

Cover Option

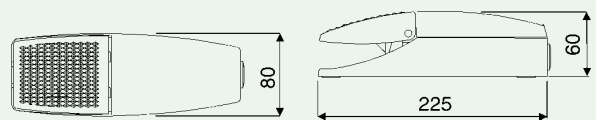

6255 - [ ] [A] [A] [A] - [ ] [A] [Z] [0]

**1. Model Number**

**2. Cover and Guard Colours**

- |                  |                  |
|------------------|------------------|
| A Cover - Yellow | B Guard - Yellow |
| C Cover - White  | D Guard - White  |
| E Cover - Blue   | F Guard - Blue   |
| G Cover - Orange | H Guard - Orange |
| M Cover - Red    | N Guard - Red    |

**3. Base Colour**

- A Black

**4. Base Configuration**

- A Entrance ports on each side of base

**5. Tread Colour**

- A Black

**6. Valve Action**

- A Momentary 5/2 Valve 1/8" BSP ISO R228 Standard
- B Momentary 5/2 Valve 1/8" NPT
- C Momentary 3/2 Valve 1/8" BSP ISO R228 Standard
- D Momentary 3/2 Valve 1/8" NPT

**Note:** Options C and D are supplied with one blanking plug

**7. Pneumatic Rating**

- A Maximum Operating Pressure 10 Bar
- Temperature -20°C to +80°C.
- Flow Rate at 6 Bar 19dm<sup>3</sup> / Sec 40 SCFM

Technical Data	
Maximum Operating Pressure	10 bar (145 PSI / 1000kPa)
Temperature Range	-20°C to + 80°C (-40°F to +176°F)
Air Condition	Filtered to 40 microns lubricated or dry
Flow Rate at 6 Bar (87 PSI / 600kPa)	19dm <sup>3</sup> / sec (40 SCFM)
Ports	ISO R228 (1/8" BSP) standard or NPT
Weights	Cover/Unguarded 800grms / Guarded 1.5kg

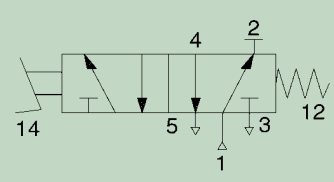
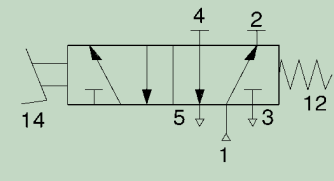
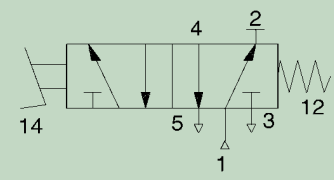
Connection Information	
<p><b>Valve connected as a 3/2 Normally Closed valve</b></p> <ul style="list-style-type: none"> <li>❖ The air supply should be connected to Port 1.</li> <li>❖ Port 2 is redundant and should be plugged with the plug fitting supplied.</li> <li>❖ The outlet is connected to Port 4.</li> <li>❖ Ports 3 and 5 are exhaust ports and should be left open to atmosphere or fitted with silencers. See note below.</li> </ul>	
<p><b>Valve connected as 3/2 Normally Open valve</b></p> <ul style="list-style-type: none"> <li>❖ The air supply should be connected to Port 1.</li> <li>❖ Port 4 is redundant and should be plugged with the plug fitting supplied.</li> <li>❖ The outlet is connected to Port 2.</li> <li>❖ Ports 3 and 5 are exhaust ports and should be left open to atmosphere or fitted with silencers. See note below.</li> </ul>	
<p><b>Valve connected as 5/2 valve</b></p> <ul style="list-style-type: none"> <li>❖ The air supply should be connected to Port 1.</li> <li>❖ Ports 2 and 4 are outlet or cylinder ports.</li> <li>❖ Ports 3 and 5 are exhaust ports and should be left open to atmosphere or fitted with silencers. See note below.</li> </ul>	

**Note:** We recommend that the exhaust ports of the valve are fitted with silencers. These will reduce the noise of the exhausting air and prevent dirt entering the valve.

A kit of 6mm fittings including elbows and silencers is available from herga, please quote part number 6050-5500-0029.

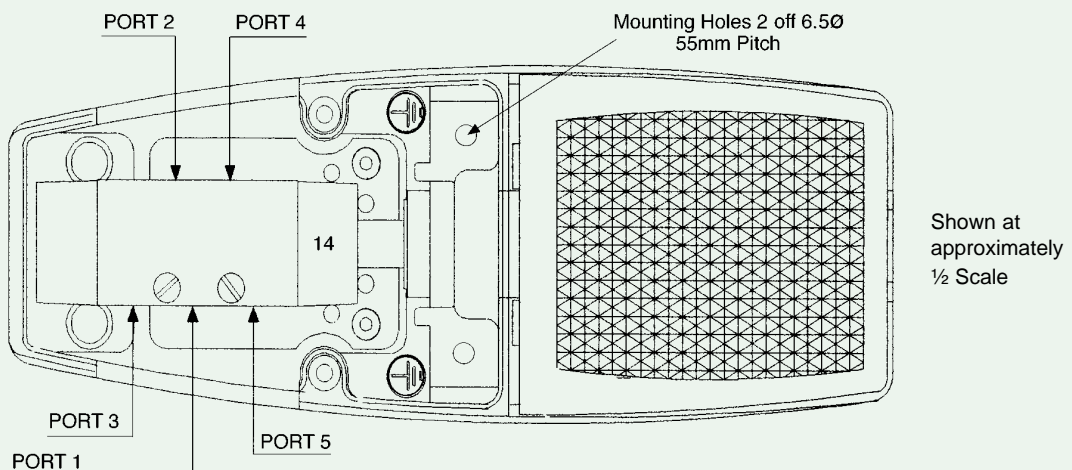

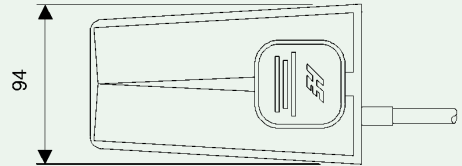
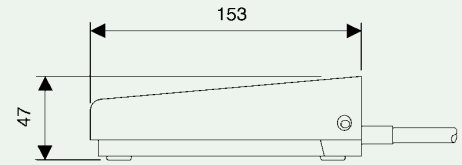

**Benefits**

- ❖ Made of die cast aluminium it's toughness and modest cost make it ideal for OEM applications
- ❖ Ideal for remote switching in harsh environmental conditions where durability is required
- ❖ Low profile designed to reduce operator fatigue

- ❖ Non electrical version available, please refer to Airswitching section
- ❖ Guard in stove enamelled mild steel as standard
- ❖ Sealed to IP40 (IP68 upon request)
- ❖ Customer colours and logos available

Model No	6254-CT	6254-CC	6254-D0	6254-DA	6254-W0
Weight	457g	475g	475g	525g	625g
Guard	Available	Available	Available	Available	Available
Black Body/Base	Die-cast aluminium	Die-cast aluminium	Die-cast aluminium	Die-cast aluminium	Die-cast aluminium
Guard Black as Std	Stove enamelled mild steel	Stove enamelled mild steel	Stove enamelled mild steel	Stove enamelled mild steel	Stove enamelled mild steel
No. of Poles	Single pole	Single pole	Double pole operating together	Double pole Two stage action	Single pole
Contact Configuration	Change over	Change over	Normally open	Normally open	Normally open
Cable	Terminal block	PVC 4 core	Terminal block	Terminal block	PVC 4 core
Length as Std	N/A	2 metres	N/A	N/A	2 metres
Conductor	N/A	0.75mm <sup>2</sup>	N/A	N/A	0.75mm <sup>2</sup>
Cable O/D	N/A	7.5mmØ (NOM)	N/A	N/A	6.8mmØ (NOM)
Current Rating	6 Amp 250V Ac 3 Amp 1/2 HP	6 Amp 250V Ac 3 Amp 1/2 HP	6 Amp 250V Ac 3 Amp 1/2 HP	6 Amp 250V Ac 3 Amp 1/2 HP	6 Amp 250V Ac (1.5A IND)
Enclosure Rating	IP40	IP40	IP40	IP40	IP67
Approvals	EN 61058-2-1, EN 61058, EN 60601-1 and EN 60950				

❖ Cordset variations of each standard option are available (up to IP68 upon request). (6254 - DO and DA versions can be cordset built).

# 6210 ~ Light Industrial Footswitch

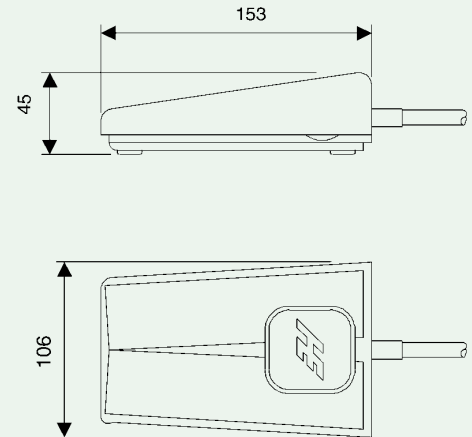

### Benefits

- ❖ Economic moulded plastic construction
- ❖ Versatile plastic switch designed to reduce operator fatigue
- ❖ Ideal for repetitive use for office equipment, domestic/medical appliances and general industrial applications
- ❖ Sealed to IP40 ( IP68 upon request)

- ❖ Non electrical versions available, please refer to Airswitching section
- ❖ Sealed to IP40 ( IP68 upon request)
- ❖ Guard available
- ❖ Customer colours and logos available
- ❖ Unlimited cordset options available

Model No	6210-ST	6210-SC	6210-W0	6210-CC	6210-DT	6210-DO
Weight Aprox	350grms	375grms	375grms	375grms	355grms	375grms
Guard	Available	Available	Available	Available	Available	Available
Material (Black Std)	Glass filled nylon	Glass filled nylon	Glass filled nylon	Glass filled nylon	Glass filled nylon	Glass filled nylon
Body (Black Std)	Glass filled nylon	Glass filled nylon	Glass filled nylon	Glass filled nylon	Glass filled nylon	Glass filled nylon
Guard (mild steel)	Stove enamelled	Stove enamelled	Stove enamelled	Stove enamelled	Stove enamelled	Stove enamelled
Number of Poles	Single pole	Single pole	Single pole	Single pole	Double pole	Double pole
Contact Configuration	Normally open	Normally open	Normally open	Change over	Normally open	Change over
Cable	Terminal block	2 core PVC	2 core PVC	4 core PVC	Terminal block	5 core PVC
Length (as Std)	N/A	2 metres	2 metres	2 Metres	N/A	2 Metres
Conductor	N/A	0.75mm <sup>2</sup>	0.75mm <sup>2</sup>	0.5mm <sup>2</sup>	N/A	0.5mm <sup>2</sup>
Cable O/D	N/A	6.8mmØ (NOM)	6.8mmØ (NOM)	6.8mmØ (NOM)	N/A	6.8mmØ (NOM)
Current Rating	6 Amp 250V Ac	6 Amp 250V Ac	6 Amp 250V Ac	3 Amp 250V Ac	6 Amp 250V Ac	3 Amp 250V Ac
Enclosure Rating	IP40	IP40	IP67	IP40	IP40	IP40
Approvals	EN 61058-2-1, EN 61058, EN 60601-1 and EN 60950					

- ❖ Cordset variations of each standard option are available (up to IP68 upon request).

**Note:** Models 6210-CC and 6210-DO contain an unconnected earth wire.

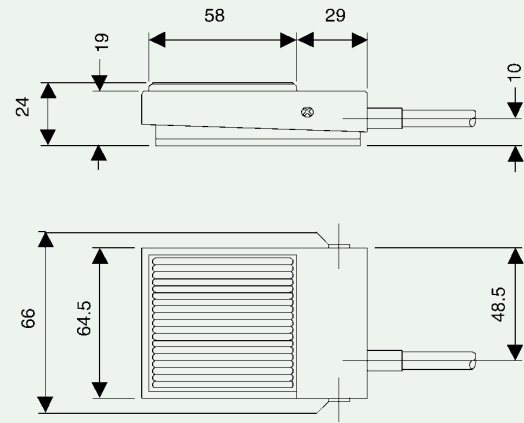
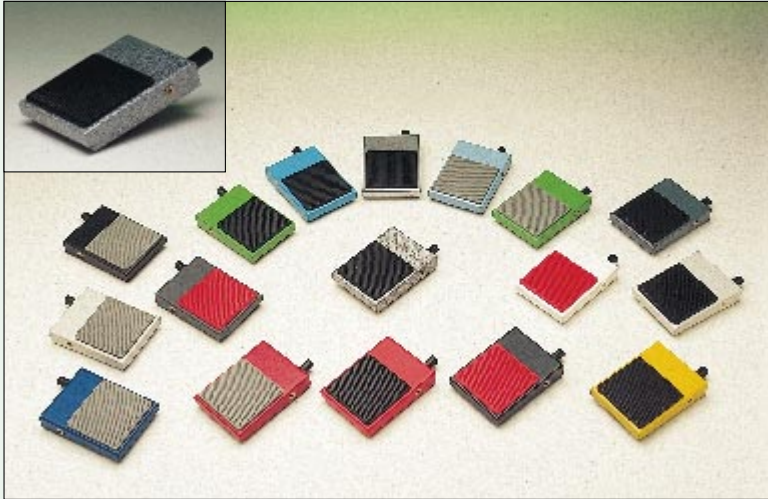

### Benefits

- ❖ Tough, compact and versatile
- ❖ Steel construction gives long life and reliability
- ❖ Non electrical versions available, please refer to Airswitching section
- ❖ Guards available

- ❖ Multi pedal versions available
- ❖ Sealed to IP40 or IP67 (IP68 upon request)
- ❖ Choice of colours and switching operations
- ❖ Customer logo's available
- ❖ Variants available for medical applications

Model No	6289-PP	6289-W0	6289-D0	6289-DA	6289-SC	6289-CC	6289-CT
Depth	89mm	89mm	89mm	89mm	89mm	89mm	89mm
Width	63mm	63mm	63mm	63mm	63mm	63mm	63mm
Height	20mm	20mm	20mm	20mm	20mm	20mm	20mm
Weight	283g	283g	283g	283g	283g	283g	283g
Guard	Available	Available	Available	Available	Available	Available	Available
Material: Body	(Grey Hammetone as Std) 16 SWG mild steel shell						
Tread	(Black as standard) Polypropylene						
Guard	2 Sizes available/Stove enamelled mild steel/Hammetone						
Number of Poles	Single pole	Single pole	Double pole	Two Stage Action	Single pole	Single pole	Single pole
Contact Configuration	Latching	Normally open	Normally open	Normally open	Normally open	Change over	Change over
Cable	3 core PVC	3 core PVC	5 core PVC	5 core PVC	3 core PVC	4 core PVC	INT. terminal block
Cable Length	2m (Std)	2m (Std)	2m (Std)	2m (Std)	2m (Std)	2m (Std)	N/A
Conductor	0.75mm <sup>2</sup>	0.75mm <sup>2</sup>	0.5mm <sup>2</sup>	0.5mm <sup>2</sup>	0.75mm <sup>2</sup>	0.5mm <sup>2</sup>	N/A
Cable O/D	6.8mm	6.8mm	6.8mm	6.8mm	6.8mm	6.8mm	7.0 grommet
Current Rating @ 250V ac	6 Amp resistive 3 Amp inductive ½ HP 250V	6 Amp resistive 1.5 Amp inductive	3 Amp resistive 3 Amp inductive ½ HP 250V	3 Amp resistive 3 Amp inductive ½ HP 250V	6 Amp resistive 3 Amp inductive ½ HP 250V	3 Amp inductive / resistive ½ HP 250V	6 Amp resistive 3 Amp ½ HP 250V
Enclosure Rating	IP40	IP67	IP40	IP40	IP40	IP40	IP40
Approvals	EN 61058-2-1, EN 61058, EN 60601-1 and EN60950						

❖ Cordset variations of each standard option are available (up to IP68 upon request).

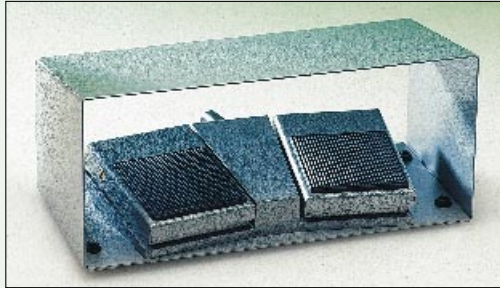

**6289-SB (Guard optional)**

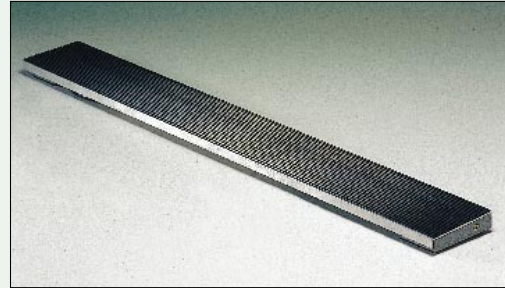

**6289-01**

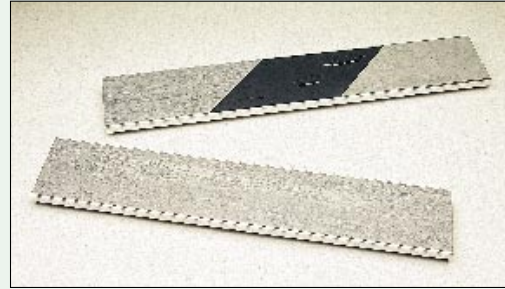

### Benefits 6289-SB

- ❖ Wide choice of switching options
- ❖ Various pedal and base colours available
- ❖ Robust high repeatability
- ❖ Customer logos available upon request

### Benefits 6289-01

- ❖ Sealed to IP40 or IP67 (IP68 upon request)
- ❖ Variable switching options
- ❖ Custom made lengths on request
- ❖ Choice of colour toppings

Model No	6289-SB Standard	6289-01 Standard
Depth	100mm	95mm
Width	180mm	760mm (200mm to 3 metres possible)
Height	32mm	25mm
Weight	795g	1200grms
Guard	230mm x 100mm x 100mm (optional extra)	N/A (possible on shorter lengths) see below
Divider Option	Fitted to central boss with or without herga logo	N/A
Material:		
Body	2 switches on diecast aluminium base	Switch bodies grey hammertone mild steel (underneath)
Tread	Std black polypropylene (grey, red & white also available)	Rubber on aluminium extrusion (or vinyl)
Guard	Painted 18 SWG mild steel	Available up to 300mm long
Colour Option	Grey hammertone (various textures and colours available)	Black rubber tread (vinyl floor types available)
Wiring Configurations	Single and double pole variants (silver as Std)	2 x N/O single pole footswitches (Change over and double pole available upon request)
Contact Configuration	Silver and gold variants available (silver as Std)	Silver and gold variants available
Cable	PVC (other types available upon request)	3 core PVC with earth as standard
Cable Length	2 metres (other lengths/types available upon request)	2 metres (can be provided with extra lengths)
Current Rating	Variations of 24V and 250V available 3 Amp ½ HP (dependent on component use)	6 Amp resistive 250V 3 Amp inductive ½ HP
Enclosure Rating	IP40 and IP67 (IP68 upon request)	IP40 (IP67 and IP68 available upon request)
Approvals	EN 61058-2-1, EN 61058, EN 60601-1 and EN 60950	EN 61058-2-1, EN 61058, EN 60601-1 and EN 60950

For IP40/IP41 Single Pole Switching



- 1. **Model Number**
- 2. **Cover and Base Colour Option**
  - A Black Cover & Black Base
  - B Grey Cover & Black Base
  - E Red Cover & Black Base
  - L Blue Cover & Black Base
- 3. **Base Configuration**
  - A Base fitted with M3 Brass Inserts
  - Z No Inserts in Base, can be mounted using self tapping screws
- 4. **Pedal Operation**
  - A Light, suitable for hand operation
  - B Heavy, suitable for foot operation
- 5. **Switch Action**
  - A Single Pole, Momentary Action, Normally Open Contact, For Cordset see Sections 6 & 8, select 2 Core Cordset
  - B Single Pole, Momentary Action, Change Over Contact, For Cordset see Sections 7 & 8, select 3 Core Cordset
  - E Kit of Parts supplied loose, Refer Box 9 for options

Only one Cordset selection can be made from 1 of the next 4 sections, enter Z - No Option Chosen for the 3 remaining sections

- 6. **2 Core & 2 Core Screened Cordsets sealed to IP40 (BS EN 60529)**
  - A 3A 24Vac/dc 2 Core 0.75mm<sup>2</sup> Colour Black 2 Metres long, Silver Contact
  - B 3A 250V 2 Core 0.75mm<sup>2</sup> Colour Black 2 Metres long, Silver Contact
  - C 1.75A 24Vac/dc 2 Core 0.22mm<sup>2</sup> Colour Black 'UL' 2 Metres long, Silver Contact
  - D 1.75A 24Vac/dc 2 Core 0.22mm<sup>2</sup> Colour White 'UL' 2 Metres long, Silver Contact
  - E 3A 24Vac/dc 2 Core 0.22mm<sup>2</sup> Shielded Flexible, Colour Black 2 Metres long, Silver Contact
  - F 0.1A 24Vac/dc 2 Core 0.75mm<sup>2</sup> Colour Black 2 Metres long, Gold Contact
  - G 0.1A 250V 2 Core 0.75mm<sup>2</sup> Colour Black 2 Metres long, Gold Contact
  - H 0.1A 24Vac/dc 2 Core 0.22mm<sup>2</sup> Colour Black 'UL' 2 Metres long, Gold Contact
  - J 0.1A 24Vac/dc 2 Core 0.22mm<sup>2</sup> Colour White 'UL' 2 Meters long, Gold Contact
  - K 0.1A 24Vac/dc 2 Core 0.22mm<sup>2</sup> Shielded Flexible Colour Black 2 Metres long, Gold Contact
  - Z No Option chosen

- 7. **3 Core & 3 Core Screened Cordsets Sealed to IP40 (BS EN 60529)**
  - A 0.1A 24Vac/dc 3 Core 0.25mm<sup>2</sup> Colour Light Grey 2 Metres Long, Gold Contact
  - B 3A 250V 3 Core 0.5mm<sup>2</sup> Colour Black 2 Metres Long, Silver Contact
  - C 0.1A 250V 3 Core 0.5mm<sup>2</sup> Colour Black 2 Metres Long, Gold Contact
  - D 3A 24Vac/dc 3 Core 0.5mm<sup>2</sup> Colour Black 2 Metres Long, Silver Contact
  - E 1.75A 24Vac/dc 3 Core 0.25mm<sup>2</sup> Colour Grey Screened 2 Metres Long, Silver Contact
  - Z No Option chosen

- 8. **2 & 3 Core Plug Cordsets Sealed To IP40 (BS EN 60529)**
  - A 0.1A 24Vac/dc 2 Core Colour Black 'UL' 2 Metres Long with 3.5mm Mono Jackplug, Gold Contact
  - B 0.1A 24Vac/dc 2 Core Colour White 'UL' 2 Metres Long with 3.5mm Mono Jackplug, Gold Contact
  - C 0.1A 24Vac/dc 2 Core Screen Colour Grey 2 Metres Long with 3.5mm Mono Jackplug, Gold Contact
  - D 0.1A 24Vac/dc 2 Core Shielded Flexible Colour Black 2 Metres Long with 6.35mm Mono Jackplug, Gold Contact
  - E 0.1A 24Vac/dc 3 Core Colour Light Grey 2 Metres Long with 3.5mm Stereo Jackplug, Gold Contact
  - F 0.1A 24Vac/dc 3 Core Screened Colour Grey 2 Metres Long with 6.35 Stereo Jackplug, Gold Contact
  - Z No Option chosen

- 9. **Non Cordset IP40 Variants - Customer to Attach Own Cordset**
  - A Fitted Change Over Microswitch Silver Contact Max. 16A 250V Lucar Blade 6.3mm x 0.8 Tag
  - B Fitted Change Over Microswitch Gold Contact Max. 0.1A 250V Lucar Blade 6.3mm x 0.8 Tag
  - C Fitted Change Over Microswitch Silver Contact Max. 16A 250V Solder Tag
  - D Fitted Change Over Microswitch Gold Contact Max. 0.1A 250V Solder Tag
  - Z No Option chosen

**Note:** The cordset rating must exceed the maximum control circuit rating. Options 9B and 9D are low power switches and must only be used in applications where suitable design constraints are met.



# 6220 ~ Leptron Foot / Palm Switch

## For IP40/IP41 Single Pole Switching

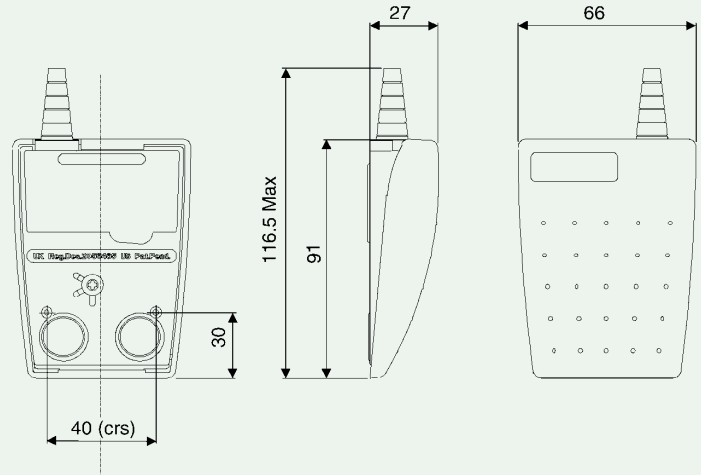

### Benefits

- ❖ Front hinged low profile footswitch designed for improved user comfort
- ❖ All plastic construction with pimple tread pattern, ideal for palm or foot operation
- ❖ Its versatility and innovative design make it an ideal product for OEM use

- ❖ Switches are designed to meet medical, industrial and office/commercial standards
- ❖ Enclosure rating IP41
- ❖ Choice of operating force
- ❖ Options for customers to fit their own cables

Depth/Length	91mm
Width	66mm
Height	27mm
Weight	212g (including cable)
Guards	Available - please contact herga for details
Material	Glass filled Nylon 6
Number of Poles	Single pole momentary
Contact Configuration	Normally open, normally closed and common (change over)
Enclosure Rating	IP40/IP41
Standards (dependent upon application chosen)	EN 61058-2-1 EN 61058 EN 60601-1 EN 60950
Options for OEM Customers	<ul style="list-style-type: none"> <li>❖ Special versions considered</li> <li>❖ Customised labels available</li> <li>❖ Additional colours may be available - please contact herga for details if your preferred colour is not shown</li> </ul>

For IP67 and Double Pole Switching

6221 - [ ] [ ] [ ] [ ] - Z [ ] [ ] [ ]

- 1. Model Number**
- 2. Cover and Base Colour Option**
  - A Black Cover & Black Base
  - B Grey Cover & Black Base
  - C Yellow Cover & Black Base
  - D Green Cover & Black Base
  - E Red Cover & Black Base
  - F Black Cover & Grey Base
  - G Grey Cover & Grey Base
  - H Yellow Cover & Grey Base
  - J Green Cover & Grey Base
  - K Red Cover & Grey Base
  - L Blue Cover & Black Base
- 3. Base Configuration**
  - A Base Fitted with M3 Brass Inserts
  - Z No Inserts in Base, can be mounted using self tapping screws
- 4. Pedal Operation**
  - A Light, suitable for hand operation
  - B Heavy, suitable for foot operation
- 5. Switch Action**
  - A Single Pole, momentary action, normally open contact  
For Cordset see section 8, select 2 core cordset
  - B Single Pole, momentary action, change over contact  
For Cordset see section 8, select 3 core cordset
  - C Double Pole, momentary action, normally open contact  
For Cordset see sections 7 & 9, select 4 core cordset

Only one Cordset selection can be made from 1 of the next 4 sections, enter Z - No Option Chosen for the 3 sections not required

- 6. Cordsets Sealed to IP40 (BS EN 60529)**
  - Z No Option chosen
- 7. Cordsets Sealed to IP40 (BS EN 60529)**
  - A 3A 24Vac/dc 4 Core 0.5mm<sup>2</sup> Colour Black 2 Metres Long, Ends stripped 30mm
  - B 3A 250Vac/dc 4 Core 0.5mm<sup>2</sup> Colour Black 2 Metres Long, Ends stripped 30mm
  - C 0.1A 24Vac/dc (Gold Contact) 4 Core 0.5mm<sup>2</sup> Colour Black 2 Metres Long, Ends stripped 30mm
  - Z No Option chosen
- 8. Cordsets Sealed to IP67 (BS EN 60529) (IP68 Upon Request)**
  - A 3A 24Vac/dc 2 Core 0.75mm<sup>2</sup> Colour Black 2 Metres long, Ends stripped 30mm
  - B 3A 250Vac/dc 2 Core 0.75mm<sup>2</sup> Colour Black 2 Metres long, Ends stripped 30mm
  - C 0.1A 24Vac/dc (Gold Contact) 2 core 0.75mm<sup>2</sup> Colour Black 2 Metres long, Ends stripped 30mm
  - D 3A 24Vac/dc 3 Core 0.5mm<sup>2</sup> Colour Black 2 Metres long, Ends stripped 30mm
  - E 3A 250Vac/dc 2 Core 0.5mm<sup>2</sup> Colour Black 2 Metres long, Ends stripped 30mm
  - F 0.1A 24Vac/dc (Gold Contact) 3 Core 0.5mm<sup>2</sup> Colour Black 2 Metres long, Ends stripped 30mm
  - Z No Option chosen
- 9. Cordsets Sealed to IP67 (BS EN 60529)**
  - A 3A 24Vac/dc 4 Core 0.5mm<sup>2</sup> Colour Black 2 Metres long, Ends stripped 30mm
  - B 3A 250Vac/dc 4 Core 0.5mm<sup>2</sup> Colour Black 2 Metres long, Ends stripped 30mm
  - C 0.1A 24Vac/dc (Gold Contact) 4 Core 0.5mm<sup>2</sup> Colour Black 2 Metres long, Ends stripped 30mm
  - Z No Option chosen

- ❖ Other feasible switching solutions can be considered upon request.
- ❖ Unlimited cordset options are available upon request.

## For IP67 and Double Pole Switching

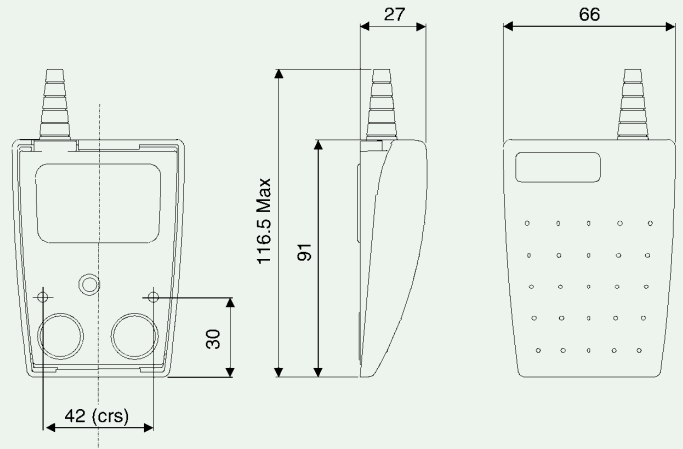

### Benefits

- ❖ Front hinged low profile footswitch designed for improved user comfort
- ❖ All plastic construction with pimple tread pattern, ideal for palm or foot operation
- ❖ Choice of operating force

- ❖ Switches are designed to meet medical, industrial and office/commercial standards
- ❖ Enclosure rating IP67 (IP68 upon request)
- ❖ Its versatility and innovative design make it an ideal product for OEM use

Depth/Length	91mm
Width	66mm
Height	27mm
Weight	212g (including cable)
Guards	Available - please contact herga for details
Material	Glass filled Nylon 6
Number of Poles	Single pole momentary or double pole momentary
Contact Configuration	Normally open, normally closed and common (change over)
Enclosure Rating	IP67 (IP68 available upon request)
Standards (dependent upon application chosen)	EN 61058-2-1 EN 61058 EN 60601-1 EN 60950
Options for OEM Customers	<ul style="list-style-type: none"> <li>❖ Special versions considered</li> <li>❖ Customised labels available</li> <li>❖ Additional colours may be available - please contact herga for details if your preferred colour is not shown</li> </ul>

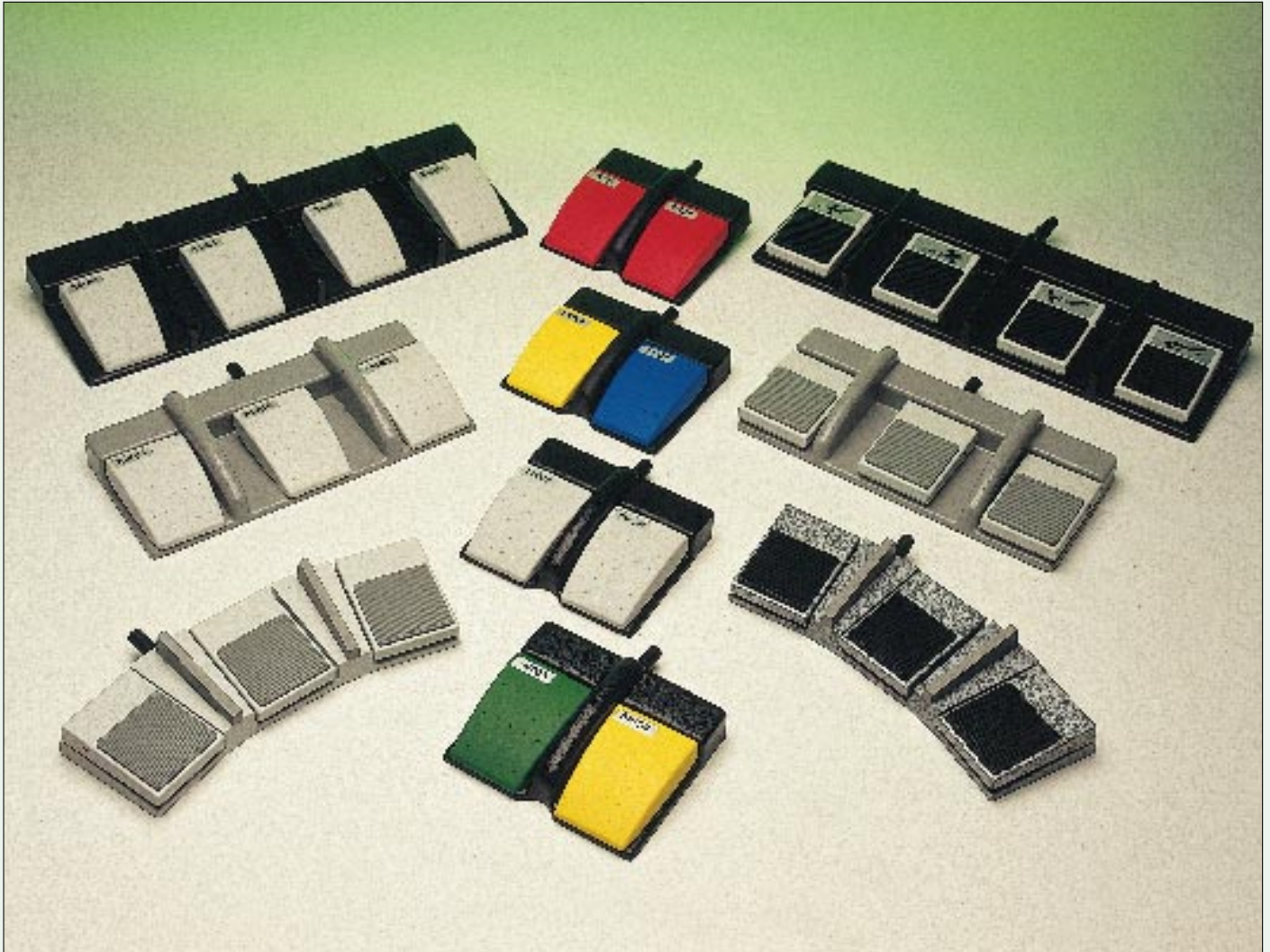

### Benefits

- ❖ Using all of the options available with the multi-pedal footswitching, we can meet a wide variety of OEM applications and comply to the differing international Standards
- ❖ Multi-pedal bases are made from a tough ABS with textured finish in grey or black or painted diecast aluminium

- ❖ Sealed to IP40 & IP67 (IP68 upon request)
- ❖ Maximum electrical ratings are determined by application
- ❖ Other pedal versions are also feasible

In keeping with our innovative design of the Leptron and 6289 styles, we can now offer equally attractive 2, 3 and 4 pedal Footswitches (larger pedals can be considered). Talk to us about your requirements for multi-pedal Footswitches. Multipedal bellow variants are also available for non electrical switching.

### Help on Standards

Herga has many years of experience of international standards. With the huge choice of footswitches available, we believe that together we can offer you the correct model to meet the various standards. However, as no one understands your market better than yourselves, the final design and responsibility of meeting the correct standards is yours.

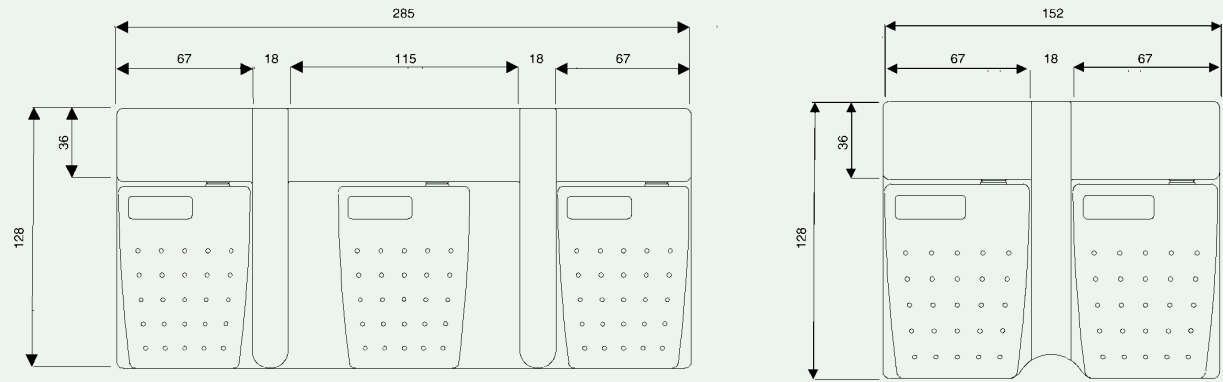
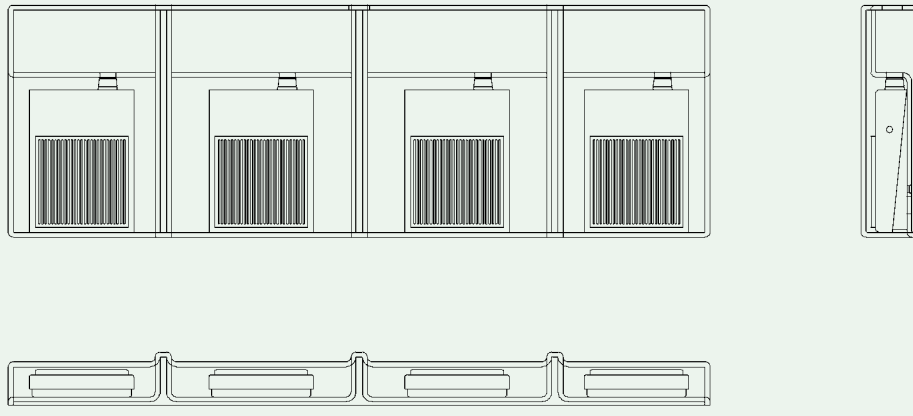
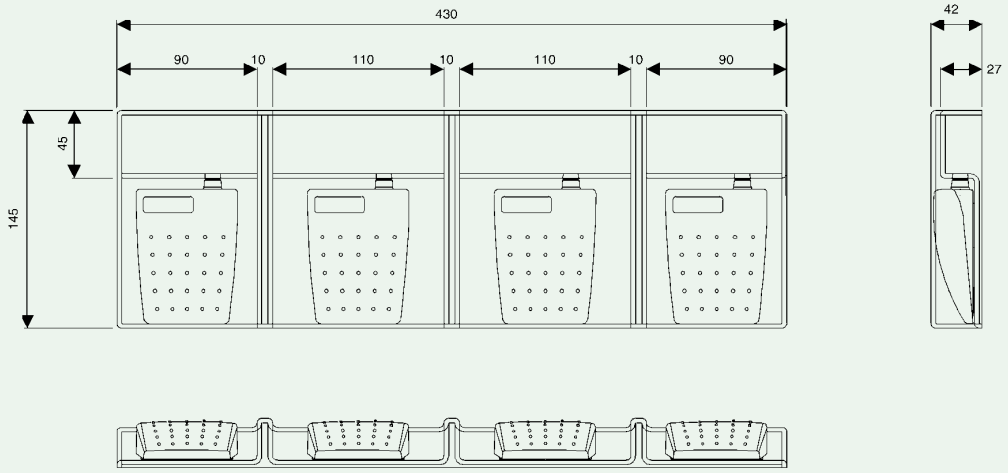

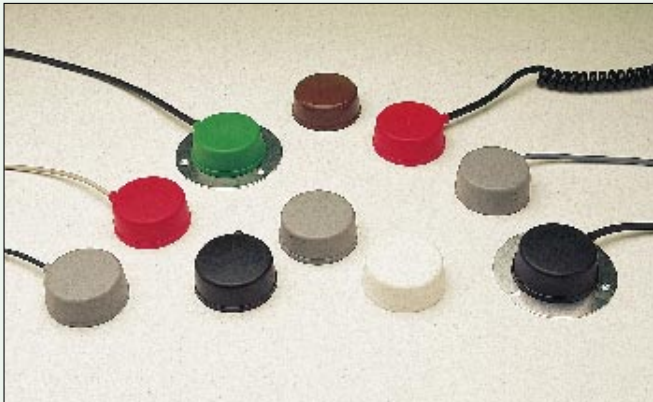

- Benefits**
- ❖ Ideal for hand or foot operation
  - ❖ Tough flexible PVC cover
  - ❖ IP67 double insulated (IP68 upon request)
  - ❖ Choice of colours (others upon request)
  - ❖ Available with aluminium base plate for added stability or permanent fixing with ant-slip foam pad
  - ❖ Change over contact variants available
  - ❖ Cordsets can be supplied with plugs/sockets etc

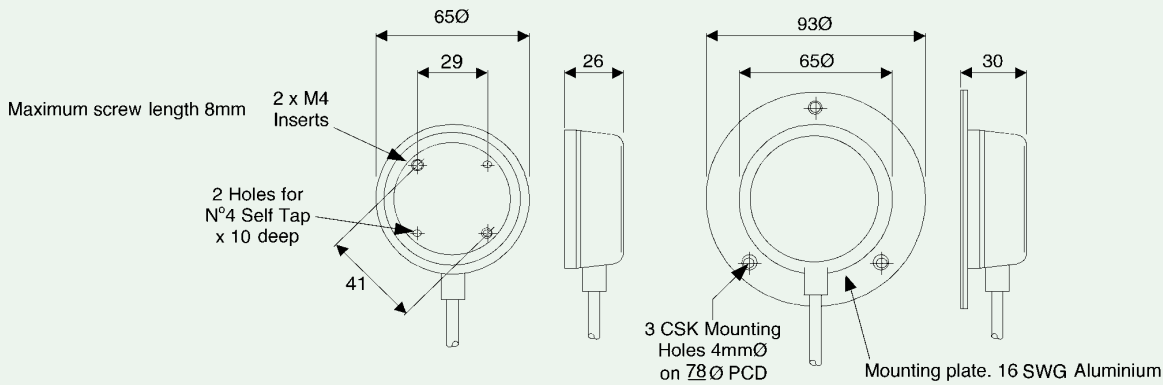

6240 -     -

**1. Model Number**

**2. Colour Option**

- |             |         |
|-------------|---------|
| A Black     | B Grey  |
| C White     | D Red   |
| E Brown/Tan | F Green |

**3. Mounting Plate**

- A Mounting Plate Fitted
- B Mounting Plate Supplied Loose with Screws/Inserts Fitted
- C No Mounting Plate but with M4 Inserts Fitted as Std in rear of base
- Z No Mounting Plate or Inserts Supplied

**4. Contact Configuration**

- A Single Pole Normally Open
- B Single Pole Normally Closed
- C Change Over Contacts (3 Core Minimum)

**5. Cable Length**

- |                 |                  |
|-----------------|------------------|
| A 2 Metres Long | B 3 Metres Long  |
| C 5 Metres Long | D 10 Metres Long |











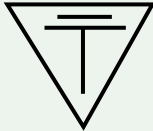











**6. IP40 Cordset Electrical Rating**

- A 3A 24V ac/dc Silver Contact, 2 Core 0.75mm<sup>2</sup> Colour Black PVC
- C 0.1A 24V ac/dc Gold Contact, 2 Core 0.75mm<sup>2</sup> Colour Black PVC
- D 3A 24V ac/dc Silver Contact, 3 Core 0.5mm<sup>2</sup> Colour Black PVC
- F 0.1A 24V ac/dc Gold Contact, 3 Core Colour Black PVC

**7. IP67 Cordset Electrical Rating**

- A 3A 24V ac/dc Silver Contact, 2 Core 0.75mm<sup>2</sup> Colour Black PVC
- C 0.1A 24V ac/dc Gold Contact, 2 Core 0.75mm<sup>2</sup> Colour Black PVC
- D 3A 24V ac/dc Silver Contact, 3 Core 0.5mm<sup>2</sup> Colour Black PVC
- F 0.1A 24V ac/dc Gold Contact, 3 Core Colour Black PVC

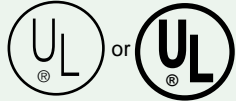
❖ 250 Volt versions available upon request

<u>Country</u>	<u>Agency</u>	<u>Mark</u>	<u>Country</u>	<u>Agency</u>	<u>Mark</u>
Australia	SAA		Japan	MITI	
Austria	OVE		Netherlands	KEMA	
Belgium	CEBEC		New Zealand	SECV SECQ SECWA EANSW ETSA HECT SANZ	
Canada	CSA				
Denmark	DEMKO		Norway	NEMKO	
Europe	MANY		Republic of South Africa	SABS	
Finland	FEI		Sweden	SEMKO	
France	UTE		Switzerland	SEV	
Germany	VDE		United Kingdom	ASTA	
				BSI	
India	ISI			BEAB	
Ireland	IIRS		United States	UL	
Italy	IMQ				

EN 60529 outlines an international classification system for the sealing effectiveness of enclosures of electrical equipment against the intrusion into the equipment of foreign bodies (i.e. tools, dust, fingers) and moisture. This classification system utilises the letters "IP" ("Ingress Protection") followed by two or three digits. (A third digit is sometimes used. An "x" is used for one of the digits if there is only one class of protection; i.e. IPX4 which addresses moisture resistance only.)

**IP54 =**

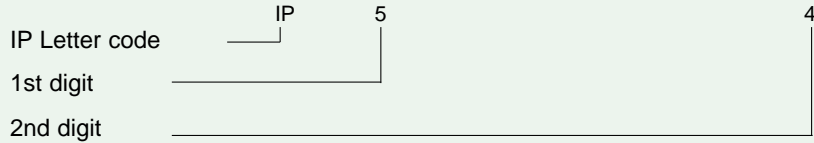

### Degrees of Protection - First Digit

The first digit of the IP code indicates the degree that persons are protected against contact with moving parts (other than smooth rotating shafts, etc.) and the degree that equipment is protected against solid foreign bodies intruding into an enclosure.

- 0 No special protection.
- 1 Protection from a large part of the body such as a hand (but no protection from deliberate access); from solid objects greater than 50mm in diameter.
- 2 Protection against fingers or other object not greater than 80mm in length and 12mm in diameter.
- 3 Protection from entry by tools, wires, etc., with a diameter or thickness greater than 2.5mm.
- 4 Protection from entry by solid objects with a diameter or thickness greater than 1.0mm.
- 5 Protection from the amount of dust that would interfere with the operation of the equipment.
- 6 Dust tight.







### Degrees of Protection - Second Digit

The second digit indicates the degree of protection of the equipment inside the enclosure against the harmful entry of various forms of moisture (e.g. dripping, spraying, submersion, etc.)

- 0 No special protection.
- 1 Protection from dripping water.
- 2 Protection from vertically dripping water.
- 3 Protection from sprayed water.
- 4 Protection from splashed water.
- 5 Protection from water projected from a nozzle.
- 6 Protection against heavy seas, or powerful jets of water.
- 7 Protection against immersion.
- 8 Protection against complete, continuous submersion in water. Submersion depth and time must be specified by the enduser. The requirement must be more onerous than IP67.

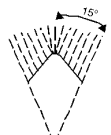
### The IP Code Symbols

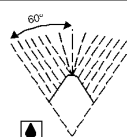
The chart at the right illustrates the use of special symbols in the IP classification system. In the "1st digit" column, note the grid-like symbols next to numbers 5 and 6. In the "2nd digit" column numbers 3-8 are symbolised by teardrop shaped symbols, sometimes enclosed in a box or a triangle, sometimes unenclosed (#7-8). These symbols can be placed on equipment to illustrate the IP protection provided.

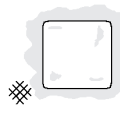
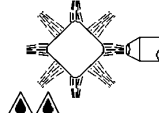
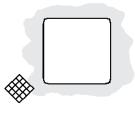
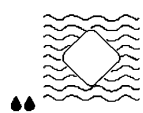
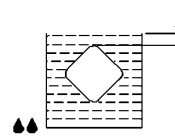
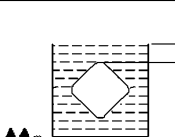
1st Digit	Protection form solid objects	2nd Digit	Protection from moisture
0	Non protected	0	Non protected
1	 Protected against solid objects greater than 50mm	1	 Protected against dripping water
2	 Protected against solid objects greater than 12mm	2	 Protected against dripping water when tilted up to 15°
3	 Protected against solid objects greater than 2.5mmØ	3	 Protected against spraying water
4	 Protected against solid objects greater than 1.0mmØ	4	 Protected against splashing water
5	 Dust protected	5	 Protected against water jets
6	 Dust tight	6	 Protected against heavy seas
		7	 Protected against the effects of immersion
		8	 Protected against submersion (see note)

**Note: EN 60529 does not specify sealing effectiveness against the following: mechanical damage of the equipment; the risk of explosions; certain types of moisture conditions, e.g. those that are produced by condensation; corrosive vapours; fungus; vermin.**







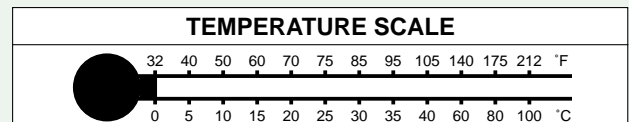

European				American			
Rating Amps	Conductor Standing		Cross Sect. Area mm <sup>2</sup>	AWG	Conductor Standing		
	Imperial	Metric			Regular	Hi Flex	
1.5	7/.0076"		0.193				
1.75		7/0.2mm	0.22	24	7/.008"	19/.0050"	
			0.357	22	7/.010"	19/.0063"	
3	14/.0076"		0.377				
3		16/0.2mm	0.5				
			0.510	20	10/.010"		
6	23/.0076"		0.65				
6		24/0.2mm	0.75				
			0.816	18	16/.010"	41/.0063"	
10		32/0.2mm	1.0				
13	40/.0076"		1.1				
			1.32	16	26/.010"	56/.0063"	
15		30/0.25mm	1.50				
18	70/.0076"		1.93				
			2.09	14	41/010"		
20		50/0.25mm	2.50				
24	110/.0076"		3.1				
			3.31	12	65/.010"		
25		56/0.3mm	4.0				
31	162/.0076"		4.5				
			5.26	10	65/0.129"		

## Important Notice

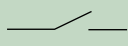
Foot controls should only be used where devices have been properly installed and are utilised so that it is impossible for the operators hands to remain within the point of operation during the machine cycle.

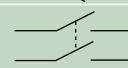
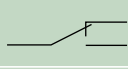
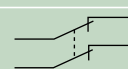
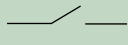

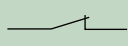
## Standard Switch Contact Configurations

Description	Form	Symbol	Description	Form	Symbol
<b>SPST-NO</b> Single pole, single throw, normally open	<b>A</b>		<b>SPDT</b> Single pole, double throw, break before make, double break moving contacts are electrically separate	<b>Zb</b>	
<b>SPST-NC</b> Single pole, single throw, normally closed	<b>B</b>		<b>DPST-NO</b> Double pole, single throw, normally open	<b>AA</b>	
<b>SPDT</b> Single pole, double throw, break before make	<b>C</b>		<b>DPST-NC</b> Double pole, single throw, normally closed	<b>BB</b>	
<b>SPST-NO</b> Single pole, single throw, normally open, double break	<b>X</b>		<b>DPST</b> Double pole, single throw, break before make	<b>AB</b>	
<b>SPST-NC</b> Single pole, single throw, normally closed, double break	<b>Y</b>		<b>DPDT</b> Double pole, double throw, break before make	<b>CC</b>	
<b>SPDT</b> Single pole, double throw, break before make, double break moving contact of same polarity	<b>Za</b>				

# Rapid Response Form (Photostat and fax back)



It is our goal to give you a response within 24 hours. By completing this form it will help us to help you!  
Thank you.

CUSTOMER			
CONTACT NAME		TEL:	FAX:

PLEASE TICK THE BOXES YOU NEED AND FILL IN YOUR REQUIREMENTS

<b>PLEASE:</b>	<input type="checkbox"/> QUOTE	<input type="checkbox"/> PROVIDE PRODUCT REF	<input type="checkbox"/> SAMPLE	<input type="checkbox"/> TIME SCALE
----------------	--------------------------------	--	---------------------------------	-------------------------------------

<b>BASIC MODEL:</b>	<input type="checkbox"/> 6251	<input type="checkbox"/> 6289 -	<input type="checkbox"/> 6210 -	<input type="checkbox"/> LEPTON/MULTIPEDAL
PLEASE REFER TO CLOSEST STANDARD OR MATRIX OPTION	<input type="checkbox"/> 6252 BG	<input type="checkbox"/> 6289 MULTIPEDAL	<input type="checkbox"/> 6240	<input type="checkbox"/> 6220
	<input type="checkbox"/> 6253 POTENTIOMETER	<input type="checkbox"/> TREADLE	<input type="checkbox"/> OTHER MULTIPEDAL	<input type="checkbox"/> 6221
	<input type="checkbox"/> 6255 MISTRAL	<input type="checkbox"/> 6254	<input type="checkbox"/>	<input type="checkbox"/>

<b>SWITCH ACTION:</b>	<input type="checkbox"/> DOUBLE ACTION	<input type="checkbox"/> MOMENTARY	<input type="checkbox"/> LATCHING	<input type="checkbox"/> OTHER
<b>CONTACTS:</b>	<input type="checkbox"/> NORMALLY OPEN	<input type="checkbox"/> NORMALLY CLOSED	<input type="checkbox"/> CHANGE OVER	<input type="checkbox"/> SINGLE POLE
	<input type="checkbox"/> DOUBLE POLE	<input type="checkbox"/> .....		

<b>MULTI PEDAL:</b>	<input type="checkbox"/> 2 PEDAL	<input type="checkbox"/> 3 PEDAL	<input type="checkbox"/> 4 PEDAL	<input type="checkbox"/> OTHER
<b>BASE:</b>	<input type="checkbox"/> CASTING	<input type="checkbox"/> VAC FORM GREY	<input type="checkbox"/> VAC FORM BLACK	<input type="checkbox"/> OTHER
<b>CONTACTS:</b>	PEDAL 1:	PEDAL 2:	PEDAL 3:	PEDAL 4:
<b>SWITCH ACTION:</b>	PEDAL 1:	PEDAL 2:	PEDAL 3:	PEDAL 4:
<b>RATING:</b>	<input type="checkbox"/> STANDARD	<input type="checkbox"/> OTHER .....		<input type="checkbox"/> GOLD CONTACT
<b>SEALED TO:</b>	<input type="checkbox"/> IP40	<input type="checkbox"/> IP67	<input type="checkbox"/> IP68	<input type="checkbox"/> OTHER

<b>COLOUR:</b>	<input type="checkbox"/> STANDARD	<input type="checkbox"/> .....	<input type="checkbox"/> POWDER PAINT	<input type="checkbox"/> WET PAINT
<b>FINISH:</b>	<input type="checkbox"/> STANDARD	<input type="checkbox"/> .....		

<b>CABLE:</b>	<input type="checkbox"/> STANDARD	<input type="checkbox"/> N/A TERMINAL VERSION	<input type="checkbox"/> SPECIAL	<input type="checkbox"/> FREE ISSUE
<b>CABLE TYPE:</b>	<input type="checkbox"/> .....		<input type="checkbox"/> SCREENED	LENGTH:

<b>PLUG/SOCKET:</b>	<input type="checkbox"/> N/A	<input type="checkbox"/> SPECIFY	<input type="checkbox"/> FITTED	<input type="checkbox"/> FREE ISSUE
---------------------	------------------------------	----------------------------------	---------------------------------	-------------------------------------

<b>APPROVALS:</b>	<input type="checkbox"/> N/A	<input type="checkbox"/> .....		
<b>APPLICATION:</b>	<input type="checkbox"/> .....		<input type="checkbox"/> INDUSTRIAL	<input type="checkbox"/> MEDICAL

<b>LABEL:</b>	<input type="checkbox"/> HERGA STD	<input type="checkbox"/> CUSTOMER LOGO (ATTACHED INFORMATION)	<input type="checkbox"/> .....
---------------	------------------------------------	---	--------------------------------

<b>PACKAGING:</b>	<input type="checkbox"/> BOXES	<input type="checkbox"/> POLY BAGS	<input type="checkbox"/> TRAYS IF AVAILABLE	<input type="checkbox"/> OTHER
-------------------	--------------------------------	------------------------------------	---	--------------------------------

<b>QUANTITY</b>	<input type="checkbox"/> PER ANNUM	<input type="checkbox"/> SAMPLES:	<input type="checkbox"/> SCHEDULED ORDER
-----------------	------------------------------------	-----------------------------------	--

**Notes:** .....

.....

.....

.....

.....

.....

.....



