

CUSTOMER Y02

Approval Sheet

DESIGNED NO.: SWITCHING POWER SUPPLIES



MODEL NO.: 3A-181WP05

ENG NO.: @3A-181WP05-029

APPROVAL		

Remark: 1).Please approve and sign back to ENG ELEC.

2).If there is no signing back,this Approval sheet will be regarded as being approved automaticly once the first P.O. of the model specified in the sheet is issued.

SUPPLIER		
DESIGN	CHECKED	APPROVED
		



英格爾

英格爾科技股份有限公司
ENG ELECTRIC CO., LTD.

台灣省桃園縣龜山鄉民生北路1段536號5樓

5F, NO.536, Sec.1.Min Sheng N.Rd;Kweishan Hsiang, Taoyuan Hsien, Taiwan, R.O.C.

TEL: 886-3-2121133, 886-3-212199

FAX: 886-3-2121561

深圳英格爾電子有限公司
SHENZHEN ENG ELECTRONICS CO., LTD.

深圳市寶安區福永鎮白石廈中核集團B棟

Block B, Nuclear Group Industrial District, Baishixia, Fuyong Town, Bao'an, Shen Zhen China

TEL: 86-755-27307512,27307515,27308750,27308755,27307208,27308202

FAX: 86-755-27308049

SHENZHEN ENG ELECTRONICS CO., LTD.

FILE NO.: EN-RDS-6224

FILE: @3A-181WP05-029

產品承認書

SHEET: 01

1 Product Characteristics:

1.1 General Description

Model 3A-181WP05 is a universal switching-mode power supply, operating at input voltage 90VAC to 255VAC and output voltage of 5V with 3A DC load

1.2 Electric Characteristics

1.2.1 Input

No	ITEM	SPECIFICATION
1.	Rated input Voltage	AC100V-240V
	Vibration input Voltage Range	AC90V-255V
2.	Frequency Rated	50-60Hz
	Frequency Vibration	47-63Hz
3.	Input Rated Current	600mA RMS Max
	Inrush Current	30A Max .at 115vac cool start
		60A Max. at 230vac cool start
4.	Leakage current	0.25mA

SHENZHEN ENG ELECTRONICS CO., LTD.

FILE NO.: EN-RDS-6224

FILE: @3A-181WP05-029

產品承認書 SHEET: 02

1.2.2 Output:

No	ITEM	V1
1.	output Voltage	5V
2.	output max. current	3A
3.	output min. Current	0A
4.	Line regulation	$\pm 1\%$
5.	Load regulation	$\pm 5\%$
6.	Over voltage protection	6.46V to 7.14V DC(output shut down)
7.	Short circuit protection	Output shut down and auto restart
8.	Ripple Voltage (L.F.)	150mV (p-p) (100V-240VAC Input)

1.2.3 HI-POT SPECIFICATION

Input to output : 3000VAC or 4242VDC 10mA 1 minute.

1.2.4 Insulation resistance:

Input to output: 500vdc to test the input to output resistance not be less 100M ohm

1.2.5 Safety approved: TUV CE UL CUL

1.3 Mechanical Characteristics

1.3.1 AC Plug : Interchangeable PIN(VDE BS SAA UL)

1.3.2 DC cord:

(1) Bending test: Life 1000 times 100% guarantee. Swings 120 from

Left to right loading weight 500g , 40 cycle/minute.

(2) Pull test : DC cord and plug ,weight 6kg for 1 minute.

1.3.3 Cord length and output plug: See Reference Att.4

1.3.4 Weight : _____ g

1.3.5 Case Size: (L)74 X (W) 43.5X (H) 34mm

1.3.6 Normal operating temperature and humidity

1.3.7 Temperature

Operating: 0°C to 40°C

Storage : -10°C to 70°C

1.3.8 Humidity

Operating : 20% to 80%.

Storage: 10% to 90%

SHENZHEN ENG ELECTRONICS CO., LTD.

FILE NO.: EN-RDS-6224

FILE: @3A-181WP05-029

產品承認書 SHEET: 04

2.Attachment:

- (Att.1) Label
- (Att.2) Outdrawing
- (Att.3) Package
- (Att.3.1) Package flow chart
- (Att.4) Dc cord drawing
- (Att.5) Material test report
- (Att.6) Electrical test report

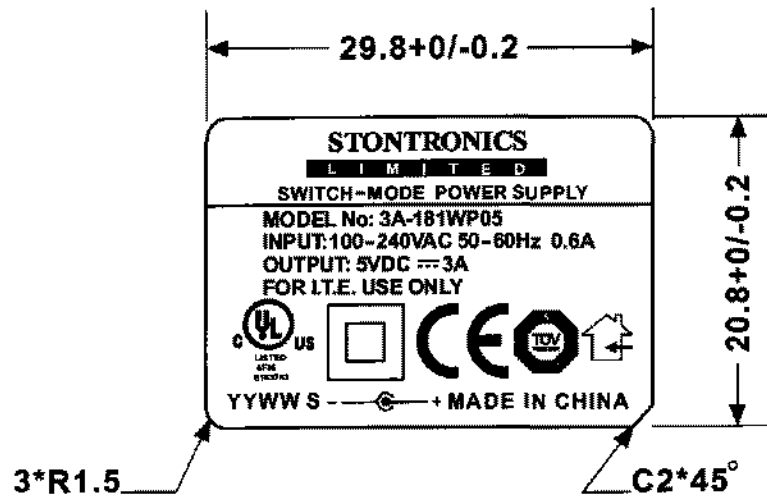

UNIT: mm

YYWW S YY:YEAR WW:WEEK S:FU YONG

ALUMINUM NAMEPLATE: ○ BLACK WORD ON SILVER BASE

○ SILVER WORD ON BLACK BASE

METALIZED POLYESTER: ● BLACK WORD ON SILVER BASE

(SILVER MATTE)

○ SILVER WORD ON BLACK BASE

TOLERANCE				

@3A-181WP05-029

DESIGNED	CHECKED	APPROVED	UNITS		TITLE	DATE
Lipp			mm	mm	LABEL	05/01/17
			SCALE	2:1	DRAWING No.	
ENG ELECTRICS CO., LTD.					N0Y02-0060	
					DRAWING NAME	REVISION
					1007	01

Att.2

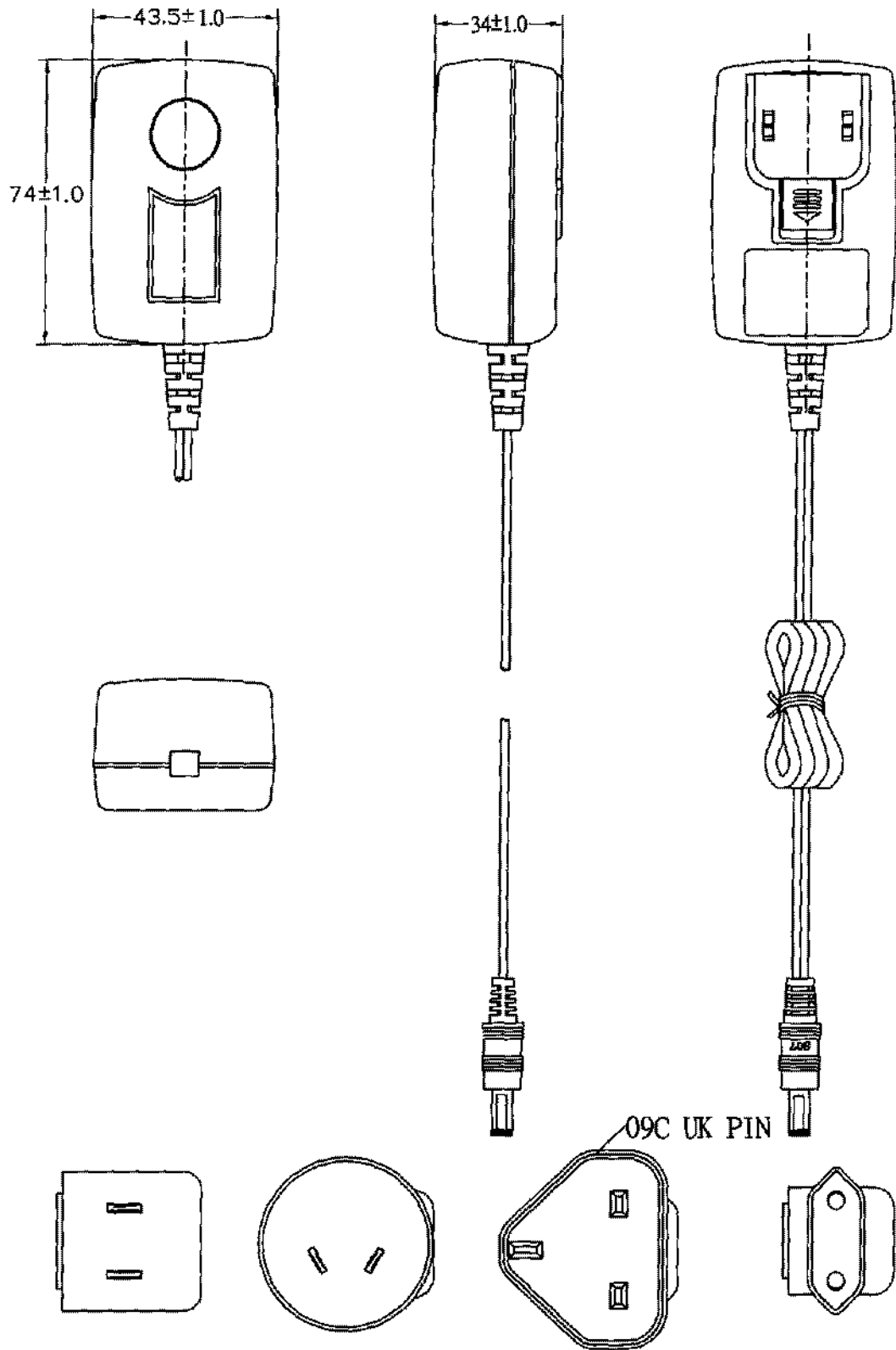

TOLERANCE				

DESIGNED	CHECKED	APPROVED		TITLE	DATE
<i>Lipz</i>				UNITS	OUTDRAWING
ENG ELECTRIC CO; LTD			mm	DRAWING No.	REVISION
			SCALE	@3A-181WP05-029	
				DRAWING NAME	
				100721	

Att.3

CARTON SIZE: 478X421X200mm

外箱尺寸 478X421X200mm

Q'TY: 60pcs(20x3)

数量 60pcs(20x3)

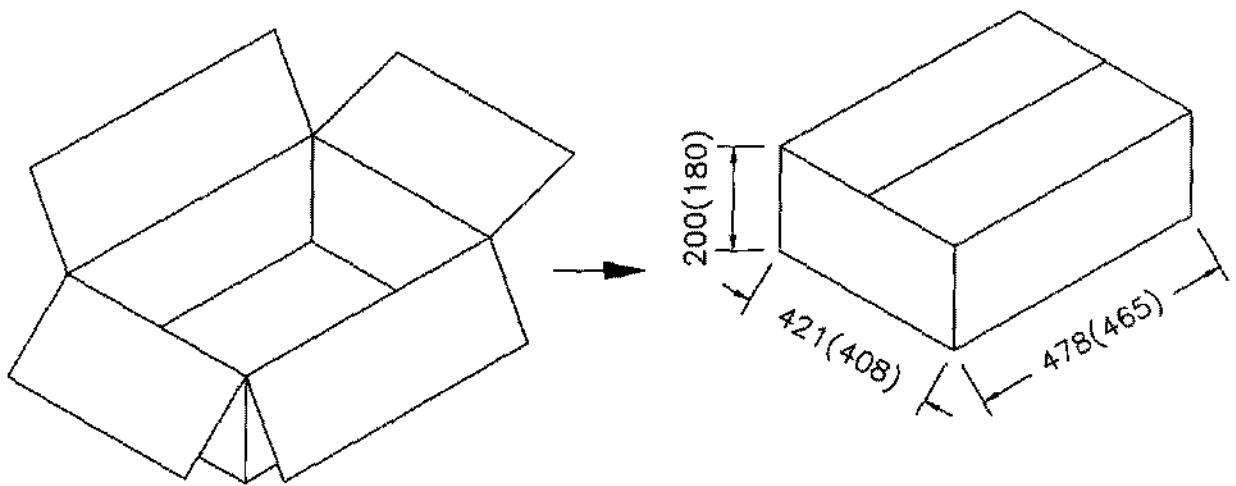
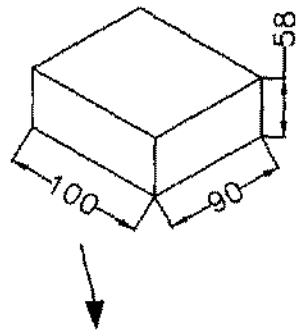

The tolerance of the internal dimensions of the carton is +7/-0

纸箱内度尺寸公差为+7/-0

TOLERANCE				

DESIGNED	CHECKED	APPROVED			TITLE	DATE
<i>Lipp</i>			UNITS	mm	PACKAGE	05/01/17
ENG ELECTRIC CO; LTD					DRAWING No.	REVISION
SCALE					P13-2030-H-50	01
DRAWING NAME					13-2030-H-50	

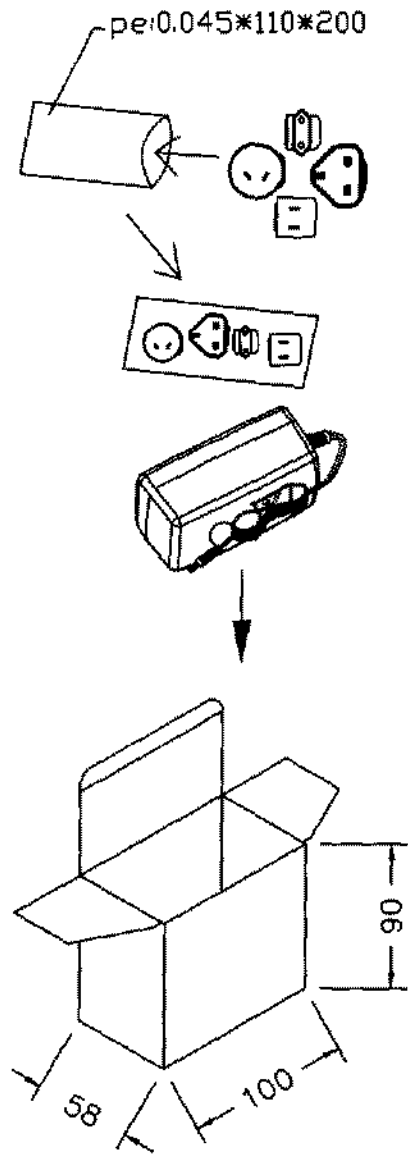



White Box: NO.13

小礼盒号码 13#

The tolerance of the external dimensions of the white box is ± 1
 小礼盒外度尺寸公差为 ± 1

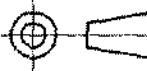
TOLERANCE				

DESIGNED	CHECKED	APPROVED			TITLE	DATE
<i>Lipin</i>			UNITS	mm	PACKAGE FLOW CHART	05/01/17
ENG ELECTRIC CO; LTD					DRAWING No.	REVISION
					@3A-181WP05-029	01
					DRAWING NAME	
					13#	

Att.4

5

推
VII