



25-mW DIRECTPATH™ STEREO HEADPHONE AMPLIFIER WITH POP SUPPRESSION

FEATURES

- **Patented DirectPath™ Technology Eliminates Need for DC-Blocking Capacitors**
 - **Outputs Biased at 0 V**
 - **Excellent Low Frequency Fidelity**
- **Active Click and Pop Suppression**
- **2.1 mA Typical Supply Current**
- **Fully Differential or Single-Ended Inputs**
 - **Built-In Resistors Reduces Component Count**
 - **Improves System Noise Performance**
- **Constant Maximum Output Power from 2.3 V to 5.5 V Supply**
 - **Simplifies Design to Prevent Acoustic Shock**
- **Improved RF Noise Immunity**
- **Microsoft™ Windows Vista™ Compliant**
- **High Power Supply Noise Rejection**
 - **100 dB PSRR at 217 Hz**
 - **90 dB PSRR at 10 kHz**
- **Wide Power Supply Range: 2.3 V to 5.5 V**
- **Gain Settings: –6 dB, 0 dB, 3 dB, and 6 dB**
- **Short-Circuit and Thermal-Overload Protection**
- **±8 kV HBM ESD Protected Outputs**
- **Small Package Available**
 - **16-Pin, 3 mm × 3 mm Thin QFN**

APPLICATIONS

- **Smart Phones / Cellular Phones**
- **Notebook Computers**
- **CD / MP3 Players**
- **Portable Gaming**

DESCRIPTION

The TPA6132A2 (sometimes referred to as TPA6132) is a DirectPath™ stereo headphone amplifier that eliminates the need for external dc-blocking output capacitors. Differential stereo inputs and built-in resistors set the device gain, further reducing external component count. Gain is selectable at –6 dB, 0 dB, 3 dB or 6 dB. The amplifier drives 25 mW into 16 Ω speakers from a single 2.3 V supply. The TPA6132A2 (TPA6132) provides a constant maximum output power independent of the supply voltage, thus facilitating the design for prevention of acoustic shock.

The TPA6132A2 (TPA6132) features fully differential inputs to reduce system noise pickup between the audio source and the headphone amplifier. The high power supply noise rejection performance and differential architecture provides increased RF noise immunity. For single-ended input signals, connect INL+ and INR+ to ground.

The device has built-in pop suppression circuitry to completely eliminate disturbing pop noise during turn-on and turn-off. The amplifier outputs have short-circuit and thermal-overload protection along with ±8 kV HBM ESD protection, simplifying end equipment compliance to the IEC 61000-4-2 ESD standard.

The TPA6132A2 (TPA6132) operates from a single 2.3 V to 5.5 V supply with 2.1 mA of typical supply current. Shutdown mode reduces supply current to less than 1 μA.

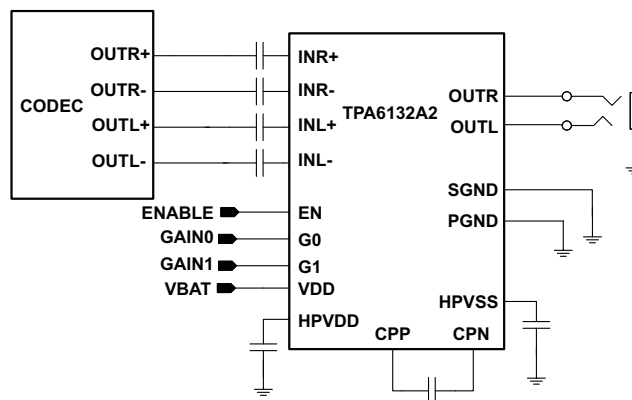

Please be aware that an important notice concerning availability, standard warranty, and use in critical applications of Texas Instruments semiconductor products and disclaimers thereto appears at the end of this data sheet.

DirectPath is a trademark of Texas Instruments.

Windows Vista is a trademark of Microsoft Corporation.

TPA6132A2

SLOS597–DECEMBER 2008

www.ti.com



These devices have limited built-in ESD protection. The leads should be shorted together or the device placed in conductive foam during storage or handling to prevent electrostatic damage to the MOS gates.

FUNCTIONAL BLOCK DIAGRAM

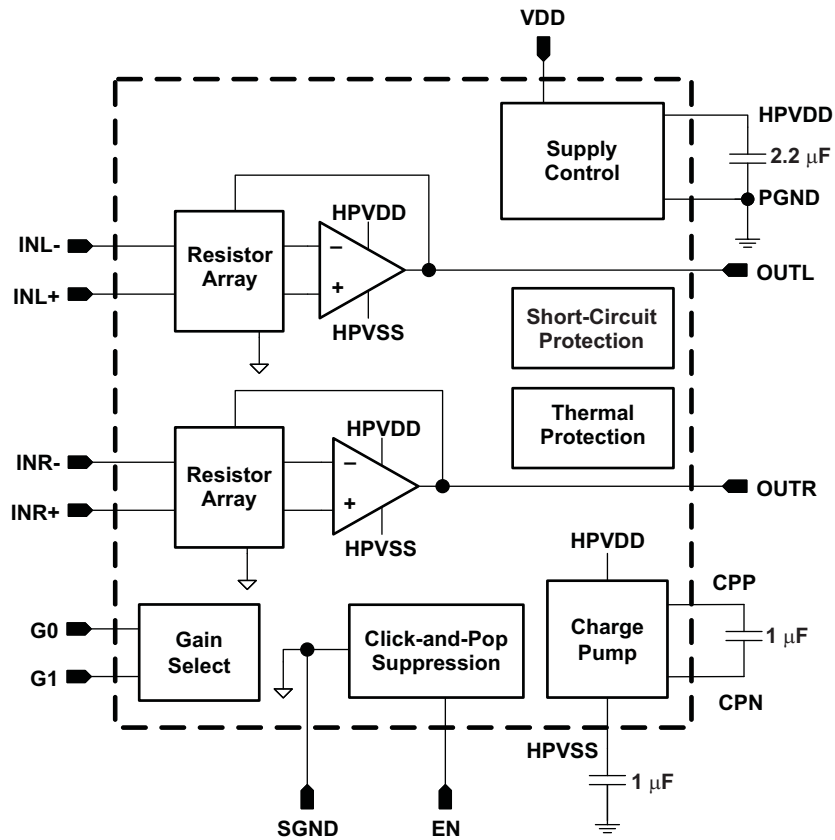

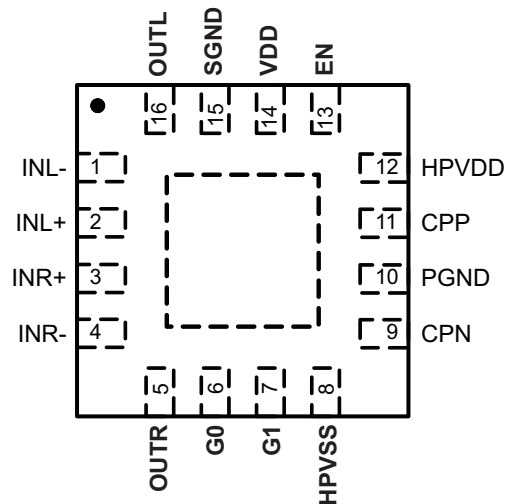
DEVICE PINOUT
**RTE (QFN) PACKAGE
(TOP VIEW)**

PIN FUNCTIONS

PIN		I/O/P	PIN DESCRIPTION
NAME	QFN		
INL-	1	I	Inverting left input for differential signals; left input for single-ended signals
INL+	2	I	Non-inverting left input for differential signals. Connect to ground for single-ended input applications
INR+	3	I	Non-inverting right input for differential signals. Connect to ground for single-ended input applications
INR-	4	I	Inverting right input for differential signals; right input for single-ended signals
OUTR	5	O	Right headphone amplifier output. Connect to right terminal of headphone jack
G0	6	I	Gain select
G1	7	I	Gain select
HPVSS	8	P	Charge pump output and negative power supply for output amplifiers; connect 1 μ F capacitor to GND
CPN	9	P	Charge pump negative flying cap. Connect to negative side of 1 μ F capacitor between CPP and CPN
PGND	10	P	Ground
CPP	11	P	Charge pump positive flying cap. Connect to positive side of 1 μ F capacitor between CPP and CPN
HPVDD	12	P	Positive power supply for headphone amplifiers. Connect to a 2.2 μ F capacitor. Do not connect to VDD
EN	13	I	Amplifier enable. Connect to logic low to shutdown; connect to logic high to activate
VDD	14	P	Positive power supply for TPA6132A2
SGND	15	I	Amplifier reference voltage. Connect to ground terminal of headphone jack
OUTL	16	O	Left headphone amplifier output. Connect to left terminal of headphone jack
Thermal Pad	–	P	Solder the exposed metal pad on the TPA6132A2RTE QFN package to the landing pad on the PCB. Connect the landing pad to ground or leave it electrically unconnected (floating).

TPA6132A2

SLOS597–DECEMBER 2008

www.ti.com

BOARD LAYOUT CONCEPT

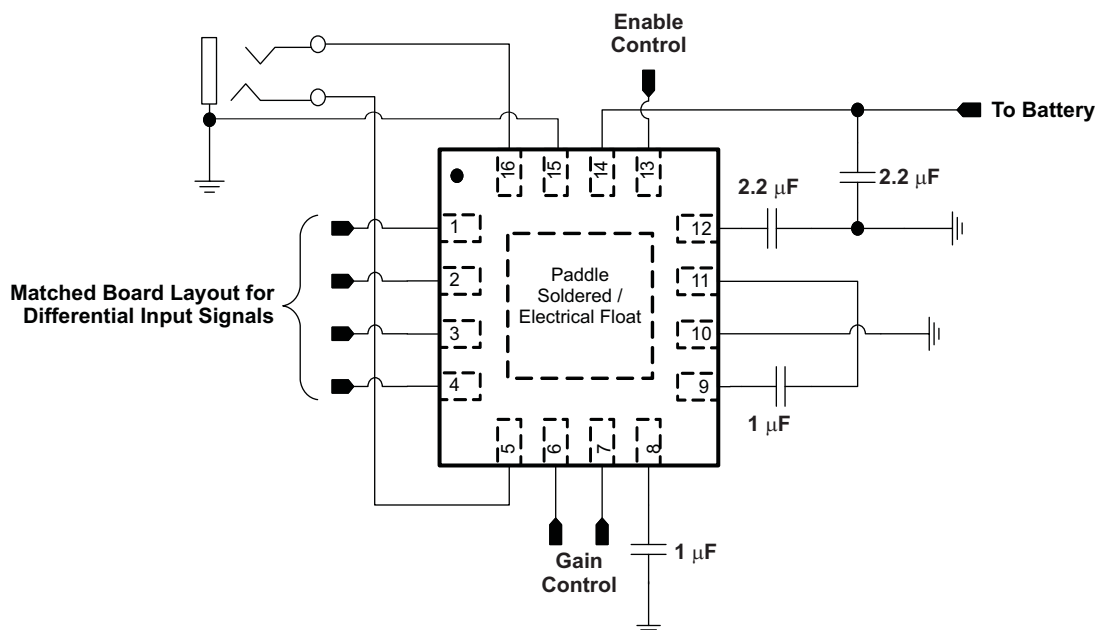

ABSOLUTE MAXIMUM RATINGS

over operating free-air temperature range, $T_A = 25^\circ\text{C}$ (unless otherwise noted)

		VALUE / UNIT
Supply voltage, VDD		-0.3 V to 6.0 V
Headphone amplifier supply voltage, HPVDD (do not connect to external supply)		-0.3 V to 1.9 V
V_I	Input voltage (INR+, INR-, INL+, INL-)	HPVSS -0.3 V to HPVDD + 0.3 V
Output continuous total power dissipation		See Dissipation Rating Table
T_A	Operating free-air temperature range	-40°C to 85°C
T_J	Operating junction temperature range	-40°C to 150°C
T_{stg}	Storage temperature range	-65°C to 85°C
ESD Protection – HBM	OUTL, OUTR	8 kV
	All Other Pins	2 kV

ORDERING GUIDE

T_A	PACKAGED DEVICES ⁽¹⁾	PART NUMBER ⁽²⁾	SYMBOL
-40°C to 85°C	16-pin, 3 mm x 3 mm Thin QFN	TPA6132A2RTER	AIWI
		TPA6132A2RTET	

(1) For the most current package and ordering information, see the Package Option Addendum at the end of this document, or see the TI Web site at www.ti.com.

(2) The RTE packages is only available taped and reeled. The suffix "R" indicates a reel of 3000, the suffix "T" indicates a reel of 250

DISSIPATION RATINGS TABLE

PACKAGE	T _A ≤ 25°C POWER RATING	DERATING FACTOR ⁽¹⁾	T _A = 70°C POWER RATING	T _A = 85°C POWER RATING
RTE (QFN)	2050 mW	48.7 °C/W	1130 mW	821 mW

(1) See JEDEC Standard 51-3 for Low-K board, JEDEC Standard 51-7 for High-K board, and JEDEC Standard 51-12 for using package thermal information. See JEDEC document page for downloadable copies: <http://www.jedec.org/download/default.cfm>.

RECOMMENDED OPERATING CONDITIONS

	MIN	MAX	UNIT
Supply voltage, VDD	2.3	5.5	V
V _{IH} High-level input voltage; EN, G0, G1	1.3		V
V _{IL} Low-level input voltage; EN, G0, G1		0.6	V
Voltage applied to Output; OUTR, OUTL (when EN = 0 V)	-0.3	3.6	V
T _A Operating free-air temperature	-40	85	°C

ELECTRICAL CHARACTERISTICS

T_A = 25°C (unless otherwise noted)

PARAMETER	TEST CONDITIONS	MIN	TYP	MAX	UNIT
Output offset voltage		-0.5		0.5	mV
Power supply rejection ratio	V _{DD} = 2.3 V to 5.5 V		100		dB
High-level output current (EN, G0, G1)				1	μA
Low-level output current (EN, G0, G1)				1	μA
Supply Current	V _{DD} = 2.3 V, No load, EN = V _{DD}		2.1	3.1	mA
	V _{DD} = 3.6 V, No load, EN = V _{DD}		2.1	3.1	
	V _{DD} = 5.5 V, No load, EN = V _{DD}		2.2	3.2	
	EN = 0 V, V _{DD} = 2.3 V to 5.5 V		0.7	1.2	

TPA6132A2

SLOS597–DECEMBER 2008

www.ti.com

OPERATING CHARACTERISTICS

 $V_{DD} = 3.6\text{ V}$, $T_A = 25^\circ\text{C}$, $R_L = 16\ \Omega$ (unless otherwise noted)

PARAMETER		TEST CONDITIONS	MIN	TYP	MAX	UNIT
P _O	Output power ⁽¹⁾ (Outputs in phase)	THD = 1%, f = 1 kHz		25		mW
		THD = 1%, f = 1 kHz, R _L = 32 Ω		22		
V _O	Output voltage ⁽¹⁾ (Outputs in phase)	THD = 1%, V _{DD} = 3.6 V, f = 1 kHz, R _L = 100 Ω		1.1		V _{RMS}
A _V	Closed-loop voltage gain (OUT / IN–)	G ₀ = 0 V, G ₁ = 0 V, (–6 dB)	–0.45	–0.5	–0.55	V/V
		G ₀ \geq 1.3 V, G ₁ = 0 V, (0 dB)	–0.95	–1.0	–1.05	
		G ₀ = 0 V, G ₁ \geq 1.3 V, (3 dB)	–1.36	–1.41	–1.46	
		G ₀ \geq 1.3 V, G ₁ \geq 1.3 V, (6 dB)	–1.95	–2.0	–2.05	
ΔA_V	Gain matching	Between Left and Right channels		1%		
R _{IN}	Input impedance (per input pin)	G ₀ = 0 V, G ₁ = 0 V, (–6 dB)		26.4		k Ω
		G ₀ \geq 1.3 V, G ₁ = 0 V, (0 dB)		19.8		
		G ₀ = 0 V, G ₁ \geq 1.3 V, (3 dB)		16.5		
		G ₀ \geq 1.3 V, G ₁ \geq 1.3 V, (6 dB)		13.2		
	Input impedance in shutdown (per input pin)	EN = 0 V		10		
V _{CM}	Input common-mode voltage range		–0.5		1.5	V
	Output impedance in shutdown	EN = 0 V		50		Ω
	Input-to-output attenuation in shutdown	EN = 0 V		80		dB
k _{SVR}	AC-power supply rejection ratio	200 mV _{pp} ripple, f = 217 Hz		–100		dB
		200 mV _{pp} ripple, f = 10 kHz		–90		
THD+N	Total harmonic distortion plus noise ⁽²⁾	P _O = 20 mW, f = 1 kHz		0.02%		
		P _O = 25 mW into 32 Ω , V _{DD} = 5.5 V, f = 1 kHz		0.01%		
SNR	Signal-to-noise ratio	P _O = 20 mW; G ₀ \geq 1.3 V, G ₁ = 0 V, (A _V = 0 dB)		100		dB
E _n	Noise output voltage	A-weighted		5.5		μV_{RMS}
f _{osc}	Charge pump switching frequency		1200	1275	1350	kHz
t _{ON}	Start-up time from shutdown			5		ms
	Crosstalk	P _O = 20 mW, f = 1 kHz		–80		dB
	Thermal shutdown	Threshold		150		$^\circ\text{C}$
		Hysteresis		20		$^\circ\text{C}$

(1) Per output channel

(2) A-weighted

TYPICAL CHARACTERISTICS

$T_A = 25^\circ\text{C}$, $V_{DD} = 3.6\text{ V}$, Gain = 0 dB, EN = 3.6 V, $C_{HPVDD} = C_{HPVSS} = 2.2\ \mu\text{F}$, $C_{INPUT} = C_{FLYING} = 1\ \mu\text{F}$, Outputs in Phase



Figure 1.

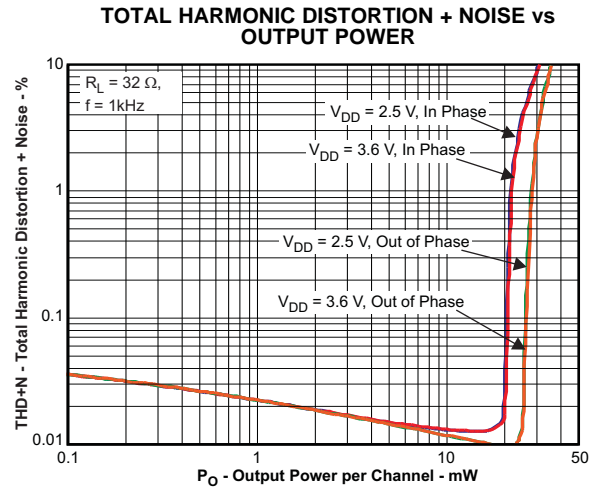

Figure 2.



Figure 3.



Figure 4.



Figure 5.



Figure 6.

TYPICAL CHARACTERISTICS (continued)

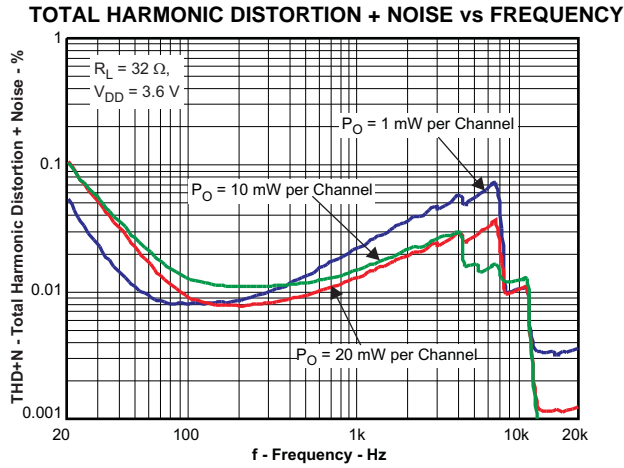

Figure 7.



Figure 8.



Figure 9.



Figure 10.

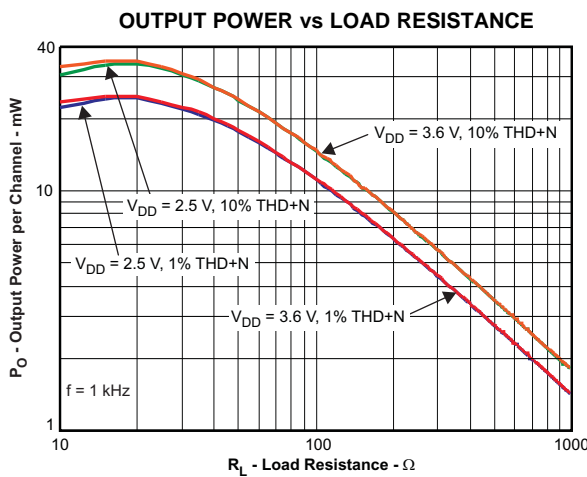

Figure 11.

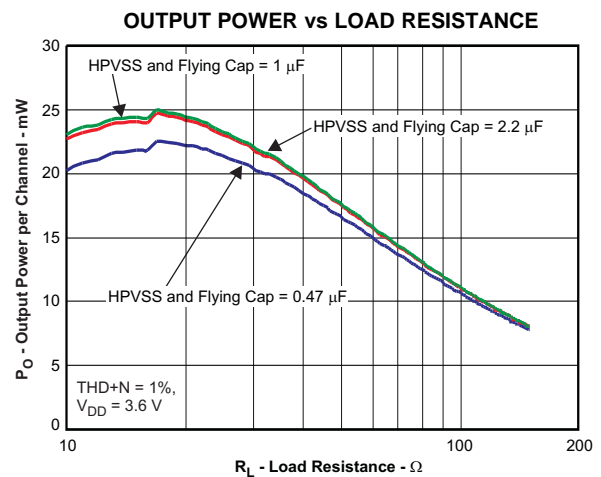

Figure 12.

TYPICAL CHARACTERISTICS (continued)



Figure 13.



Figure 14.



Figure 15.



Figure 16.



Figure 17.

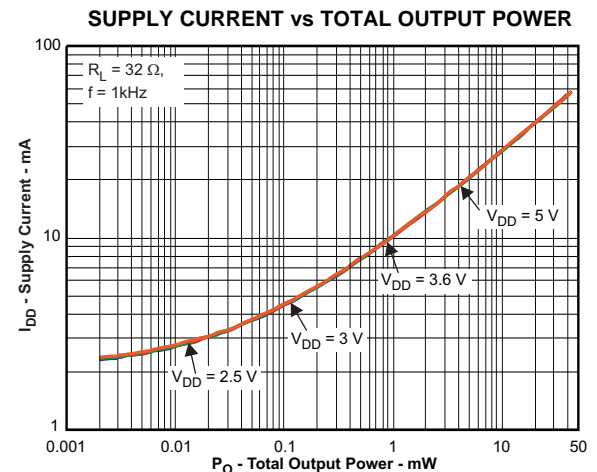

Figure 18.

TYPICAL CHARACTERISTICS (continued)

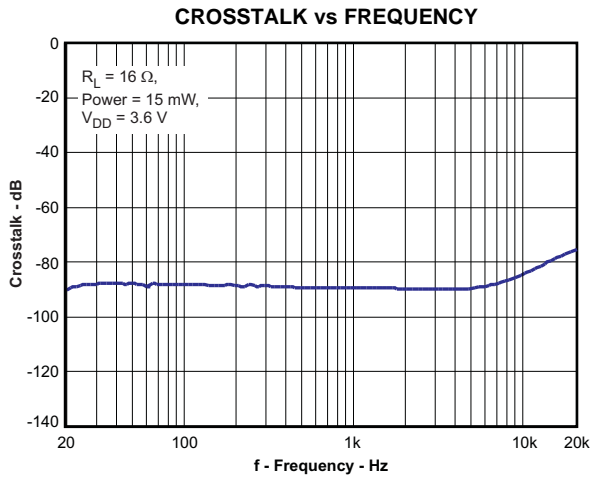

Figure 19.

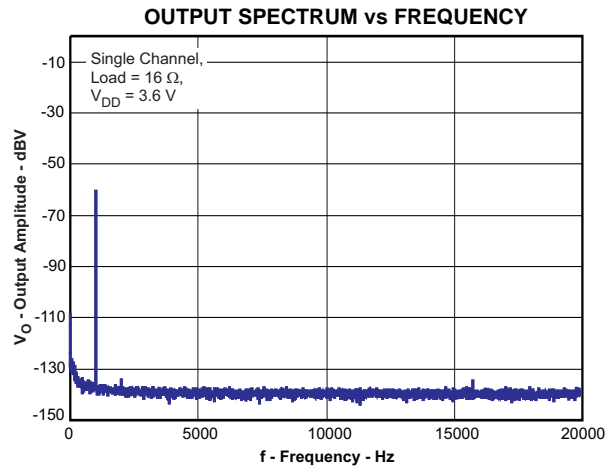

Figure 20.

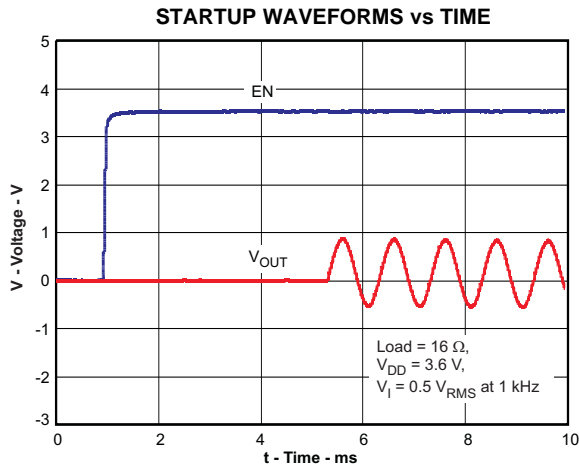

Figure 21.

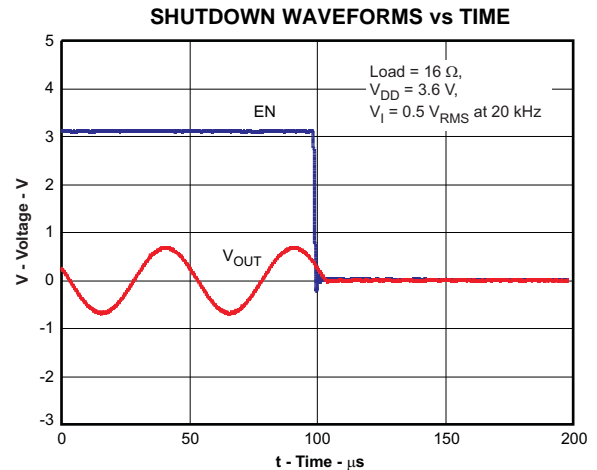

Figure 22.

APPLICATION INFORMATION

APPLICATION CIRCUIT

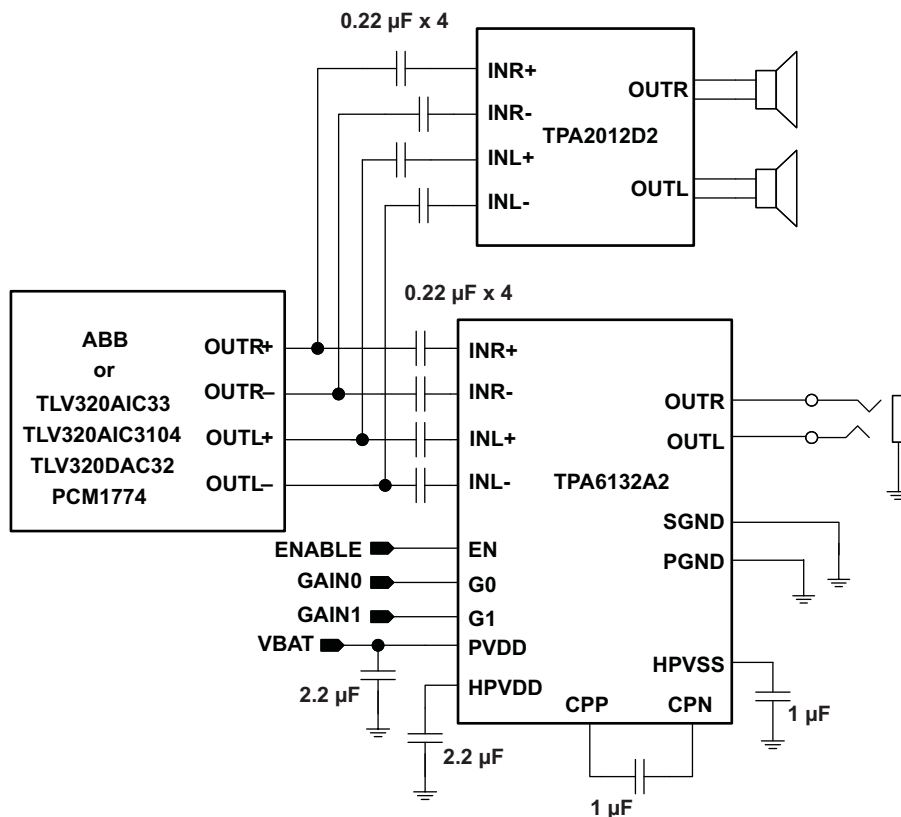

Figure 23. Typical Application Configuration with Differential Input Signals

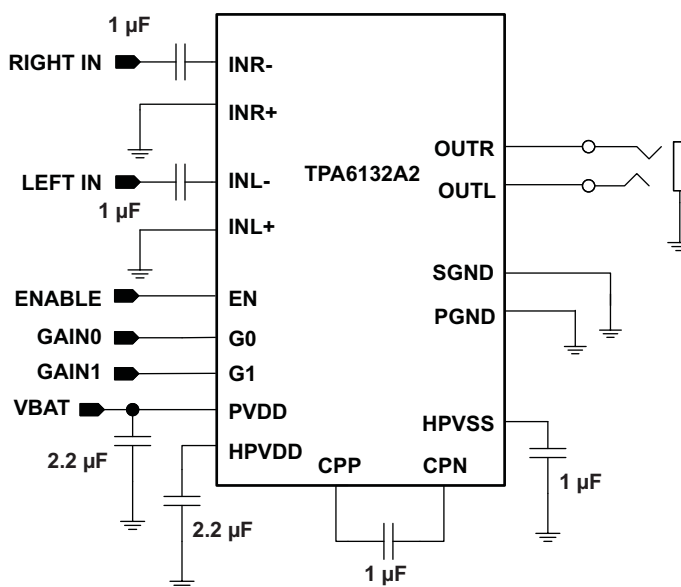

Figure 24. Typical Application Configuration with Single-Ended Input Signals

GAIN CONTROL

The TPA6132A2 has four gain settings which are controlled with pins G0 and G1. The following table gives an overview of the gain function.

G0 VOLTAGE	G1 VOLTAGE	AMPLIFIER GAIN
≤ 0.5 V	≤ 0.5 V	–6 dB
≥ 1.3 V	≤ 0.5 V	0 dB
≤ 0.5 V	≥ 1.3 V	3 dB
≥ 1.3 V	≥ 1.3 V	6 dB

Table 1. Windows Vista™ Premium Mobile Mode Specifications

Device Type	Requirement	Windows Premium Mobile Vista Specifications	TPA6132A2 Typical Performance
Analog Speaker Line Jack ($R_L = 10\text{ k}\Omega$, FS = 0.707 Vrms)	THD+N	≤ –65 dB FS [20 Hz, 20 kHz]	–75 dB FS [20 Hz, 20 kHz]
	Dynamic Range with Signal Present	≤ –80 dB FS A-Weight	–100 dB FS A-Weight
	Line Output Crosstalk	≤ –60 dB [20 Hz, 20 kHz]	–90 dB [20 Hz, 20 kHz]
Analog Headphone Out Jack ($R_L = 32\Omega$, FS = 0.300 Vrms)	THD+N	≤ –45 dB FS [20 Hz, 20 kHz]	–65 dB FS [20 Hz, 20 kHz]
	Dynamic Range with Signal Present	≤ –80 dB FS A-Weight	–94 dB FS A-Weight
	Headphone Output Crosstalk	≤ –60 dB [20 Hz, 20 kHz]	–90 dB [20 Hz, 20 kHz]

HEADPHONE AMPLIFIERS

Single-supply headphone amplifiers typically require dc-blocking capacitors to remove dc bias from their output voltage. The top drawing in [Figure 25](#) illustrates this connection. If dc bias is not removed, large dc current will flow through the headphones which wastes power, clip the output signal, and potentially damage the headphones.

These dc-blocking capacitors are often large in value and size. Headphone speakers have a typical resistance between 16 Ω and 32 Ω . This combination creates a high-pass filter with a cutoff frequency as shown in [Equation 1](#), where R_L is the load impedance, C_O is the dc-block capacitor, and f_c is the cutoff frequency.

$$f_c = \frac{1}{2\pi R_L C_O} \quad (1)$$

For a given high-pass cutoff frequency and load impedance, the required dc-blocking capacitor is found as:

$$C_O = \frac{1}{2\pi f_c R_L} \quad (2)$$

Reducing f_c improves low frequency fidelity and requires a larger dc-blocking capacitor. To achieve a 20 Hz cutoff with 16 Ω headphones, C_O must be at least 500 μF . Large capacitor values require large packages, consuming PCB area, increasing height, and increasing cost of assembly. During start-up or shutdown the dc-blocking capacitor has to be charged or discharged. This causes an audible pop on start-up and power-down. Large dc-blocking capacitors also reduce audio output signal fidelity.

Two different headphone amplifier architectures are available to eliminate the need for dc-blocking capacitors. The Capless amplifier architecture is similar provides a reference voltage to the headphone connector shield pin as shown in the middle drawing of [Figure 25](#). The audio output signals are centered around this reference voltage, which is typically half of the supply voltage to allow symmetrical output voltage swing.

When using a Capless amplifier do not connect the headphone jack shield to any ground reference or large currents will result. This makes Capless amplifiers ineffective for plugging non-headphone accessories into the headphone connector. Capless amplifiers are useful only with floating GND headphones.

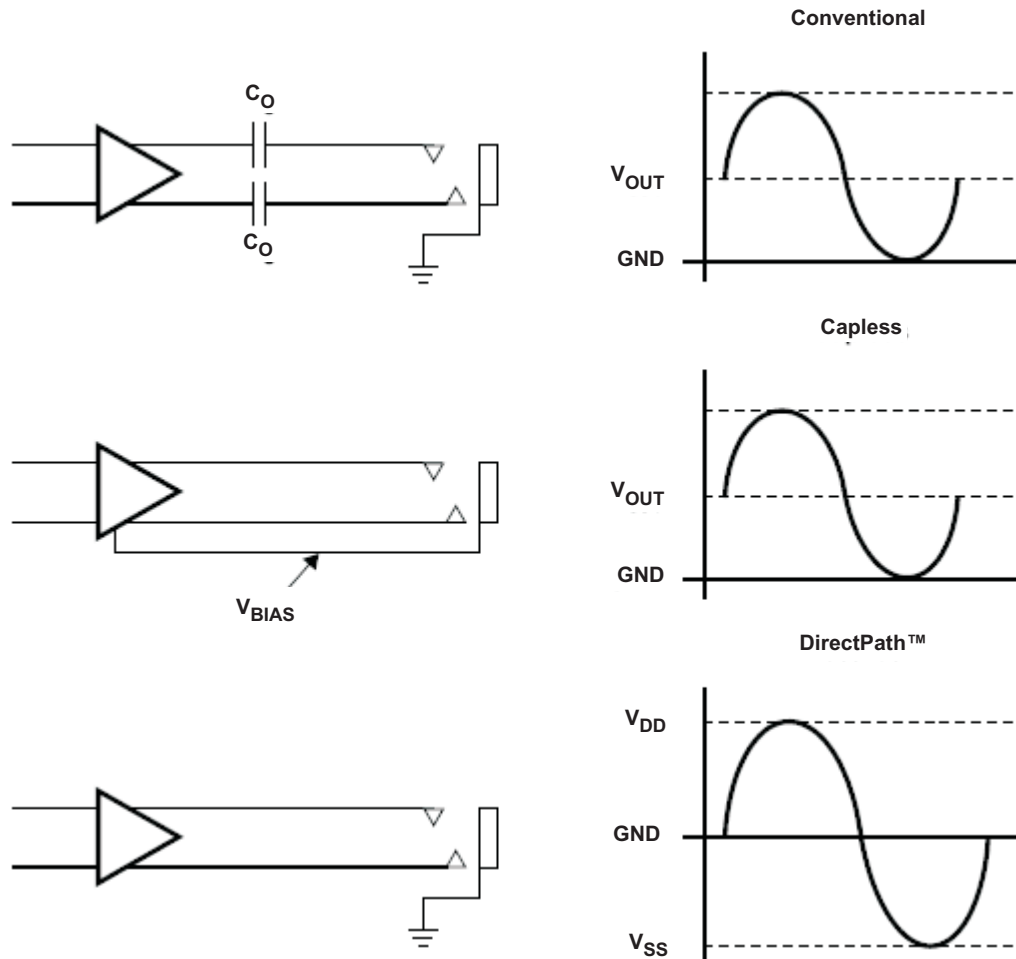

Figure 25. Amplifier Applications

The DirectPath™ amplifier architecture operates from a single supply voltage and uses an internal charge pump to generate a negative supply rail for the headphone amplifier. The output voltages are centered around 0 V and are capable of positive and negative voltage swings as shown in the bottom drawing of Figure 25. DirectPath amplifiers require no output dc-blocking capacitors. The headphone connector shield pin connects to ground and will interface with headphones and non-headphone accessories. The TPA6132A2 is a DirectPath amplifier.

ELIMINATING TURN-ON POP AND POWER SUPPLY SEQUENCING

The TPA6132A2 has excellent noise and turn-on / turn-off pop performance. It uses an integrated click-and-pop suppression circuit to allow fast start-up and shutdown without generating any voltage transients at the output pins. Typical start-up time from shutdown is 5 ms.

DirectPath technology keeps the output dc voltage at 0 V even when the amplifier is powered up. The DirectPath technology together with the active pop-and-click suppression circuit eliminates audible transients during start up and shutdown.

Use input coupling capacitors to ensure inaudible turn-on pop. Activate the TPA6132A2 after all audio sources have been activated and their output voltages have settled. On power-down, deactivate the TPA6132A2 before deactivating the audio input source. The EN pin controls device shutdown: Set to 0.6 V or lower to deactivate the TPA6132A2; set to 1.3 V or higher to activate.

RF AND POWER SUPPLY NOISE IMMUNITY

The TPA6132A2 employs a new differential amplifier architecture to achieve high power supply noise rejection and RF noise rejection. RF and power supply noise are common in modern electronics. Although RF frequencies are much higher than the 20 kHz audio band, signal modulation often falls in-band. This, in turn, modulates the supply voltage, allowing a coupling path into the audio amplifier. A common example is the 217 Hz GSM frame-rate buzz often heard from an active speaker when a cell phone is placed nearby during a phone call.

The TPA6132A2 has excellent rejection of power supply and RF noise, preventing audio signal degradation.

CONSTANT MAXIMUM OUTPUT POWER AND ACOUSTIC SHOCK PREVENTION

Typically the output power increases with increasing supply voltage on an unregulated headphone amplifier. The TPA6132A2 maintains a constant output power independent of the supply voltage. Thus the design for prevention of acoustic shock (hearing damage due to exposure to a loud sound) is simplified since the output power will remain constant, independent of the supply voltage. This feature allows maximizing the audio signal at the lowest supply voltage.

INPUT COUPLING CAPACITORS

Input coupling capacitors block any dc bias from the audio source and ensure maximum dynamic range. Input coupling capacitors also minimize TPA6132A2 turn-on pop to an inaudible level.

The input capacitors are in series with TPA6132A2 internal input resistors, creating a high-pass filter. [Equation 3](#) calculates the high-pass filter corner frequency. The input impedance, R_{IN} , is dependent on device gain. Larger input capacitors decrease the corner frequency. See the Operating Characteristics table for input impedance values.

$$f_C = \frac{1}{2\pi R_{IN} C_{IN}} \quad (3)$$

For a given high-pass cutoff frequency, the minimum input coupling capacitor is found as:

$$C_{IN} = \frac{1}{2\pi f_C R_{IN}} \quad (4)$$

Example: Design for a 20 Hz corner frequency with a TPA6132A2 gain of +6 dB. The Operating Characteristics table gives R_{IN} as 13.2 k Ω . [Equation 4](#) shows the input coupling capacitors must be at least 0.6 μ F to achieve a 20 Hz high-pass corner frequency. Choose a 0.68 μ F standard value capacitor for each TPA6132A2 input (X5R material or better is required for best performance).

Input capacitors can be removed provided the TPA6132A2 inputs are driven differentially with less than ± 1 V and the common-mode voltage is within the input common-mode range of the amplifier. Without input capacitors turn-on pop performance may be degraded and should be evaluated in the system.

CHARGE PUMP FLYING CAPACITOR AND HPVSS CAPACITOR

The TPA6132A2 uses a built-in charge pump to generate a negative voltage supply for the headphone amplifiers. The charge pump flying capacitor connects between CPP and CPN. It transfers charge to generate the negative supply voltage. The HPVSS capacitor must be at least equal in value to the flying capacitor to allow maximum charge transfer. Use low equivalent-series-resistance (ESR) ceramic capacitors (X5R material or better is required for best performance) to maximize charge pump efficiency. Typical values are 1 μ F to 2.2 μ F for the HPVSS and flying capacitors. Although values down to 0.47 μ F can be used, total harmonic distortion (THD) will increase.

POWER SUPPLY AND HPVDD DECOUPLING CAPACITORS

The TPA6132A2 DirectPath headphone amplifier requires adequate power supply decoupling to ensure that output noise and total harmonic distortion (THD) remain low. Use good low equivalent-series-resistance (ESR) ceramic capacitors (X5R material or better is required for best performance). Place a 2.2 μF capacitor within 5 mm of the VDD pin. Reducing the distance between the decoupling capacitor and VDD minimizes parasitic inductance and resistance, improving TPA6132A2 supply rejection performance. Use 0402 or smaller size capacitors if possible.

For additional supply rejection, connect an additional 10 μF or higher value capacitor between VDD and ground. This will help filter lower frequency power supply noise. The high power supply rejection ratio (PSRR) of the TPA6132A2 makes the 10 μF capacitor unnecessary in most applications.

Connect a 2.2 μF capacitor between HPVDD and ground. This ensures the amplifier internal bias supply remains stable and maximizes headphone amplifier performance.

WARNING:

DO NOT connect HPVDD directly to VDD or an external supply voltage. The voltage at HPVDD is generated internally. Connecting HPVDD to an external voltage can damage the device.

LAYOUT RECOMMENDATIONS

EXPOSED PAD ON TPA6132A2RTE

Solder the exposed metal pad on the TPA6132A2RTE QFN package to the landing pad on the PCB. Connect the landing pad to ground or leave it electrically unconnected (floating). *Do not connect the landing pad to VDD or to any other power supply voltage.*

If the pad is grounded, it must be connected to the same ground as the PGND pin (10). See the layout and mechanical drawings at the end of the data sheet for proper sizing. Soldering the thermal pad is required for mechanical reliability and enhances thermal conductivity of the package.

WARNING:

DO NOT connect the TPA6132A2RTE exposed metal pad to VDD or any other power supply voltage.

GND CONNECTIONS

The SGND pin is an input reference and must be connected to the headphone ground connector pin. This ensures no turn-on pop and minimizes output offset voltage. Do not connect more than ± 0.3 V to SGND.

PGND is a power ground. Connect supply decoupling capacitors for VDD, HPVDD, and HPVSS to PGND.

POWER SUPPLY CONNECTIONS

Connect the supply voltage to the VDD pin and decouple it with an X5R or better capacitor. Connect the HPVDD pin only to a 2.2 μF , X5R or better, capacitor. Do not connect HPVDD to an external voltage supply. Place both capacitors within 5 mm of their associated pins on the TPA6132A2. Ensure that the ground connection of each of the capacitors has a minimum length return path to the device. Failure to properly decouple the TPA6132A2 may degrade audio or EMC performance.

PACKAGING INFORMATION

Orderable Device	Status ⁽¹⁾	Package Type	Package Drawing	Pins	Package Qty	Eco Plan ⁽²⁾	Lead/Ball Finish	MSL Peak Temp ⁽³⁾
TPA6132A2RTER	ACTIVE	WQFN	RTE	16	3000	Green (RoHS & no Sb/Br)	CU NIPDAU	Level-2-260C-1 YEAR
TPA6132A2RTET	ACTIVE	WQFN	RTE	16	250	Green (RoHS & no Sb/Br)	CU NIPDAU	Level-2-260C-1 YEAR

⁽¹⁾ The marketing status values are defined as follows:

ACTIVE: Product device recommended for new designs.

LIFEBUY: TI has announced that the device will be discontinued, and a lifetime-buy period is in effect.

NRND: Not recommended for new designs. Device is in production to support existing customers, but TI does not recommend using this part in a new design.

PREVIEW: Device has been announced but is not in production. Samples may or may not be available.

OBsolete: TI has discontinued the production of the device.

⁽²⁾ Eco Plan - The planned eco-friendly classification: Pb-Free (RoHS), Pb-Free (RoHS Exempt), or Green (RoHS & no Sb/Br) - please check <http://www.ti.com/productcontent> for the latest availability information and additional product content details.

TBD: The Pb-Free/Green conversion plan has not been defined.

Pb-Free (RoHS): TI's terms "Lead-Free" or "Pb-Free" mean semiconductor products that are compatible with the current RoHS requirements for all 6 substances, including the requirement that lead not exceed 0.1% by weight in homogeneous materials. Where designed to be soldered at high temperatures, TI Pb-Free products are suitable for use in specified lead-free processes.

Pb-Free (RoHS Exempt): This component has a RoHS exemption for either 1) lead-based flip-chip solder bumps used between the die and package, or 2) lead-based die adhesive used between the die and leadframe. The component is otherwise considered Pb-Free (RoHS compatible) as defined above.

Green (RoHS & no Sb/Br): TI defines "Green" to mean Pb-Free (RoHS compatible), and free of Bromine (Br) and Antimony (Sb) based flame retardants (Br or Sb do not exceed 0.1% by weight in homogeneous material)

⁽³⁾ MSL, Peak Temp. -- The Moisture Sensitivity Level rating according to the JEDEC industry standard classifications, and peak solder temperature.

Important Information and Disclaimer:The information provided on this page represents TI's knowledge and belief as of the date that it is provided. TI bases its knowledge and belief on information provided by third parties, and makes no representation or warranty as to the accuracy of such information. Efforts are underway to better integrate information from third parties. TI has taken and continues to take reasonable steps to provide representative and accurate information but may not have conducted destructive testing or chemical analysis on incoming materials and chemicals. TI and TI suppliers consider certain information to be proprietary, and thus CAS numbers and other limited information may not be available for release.

In no event shall TI's liability arising out of such information exceed the total purchase price of the TI part(s) at issue in this document sold by TI to Customer on an annual basis.

TAPE AND REEL INFORMATION



QUADRANT ASSIGNMENTS FOR PIN 1 ORIENTATION IN TAPE



*All dimensions are nominal

Device	Package Type	Package Drawing	Pins	SPQ	Reel Diameter (mm)	Reel Width W1 (mm)	A0 (mm)	B0 (mm)	K0 (mm)	P1 (mm)	W (mm)	Pin1 Quadrant
TPA6132A2RTER	WQFN	RTE	16	3000	330.0	12.4	3.3	3.3	1.1	8.0	12.0	Q2
TPA6132A2RTET	WQFN	RTE	16	250	180.0	12.4	3.3	3.3	1.1	8.0	12.0	Q2

TAPE AND REEL BOX DIMENSIONS



*All dimensions are nominal

Device	Package Type	Package Drawing	Pins	SPQ	Length (mm)	Width (mm)	Height (mm)
TPA6132A2RTER	WQFN	RTE	16	3000	346.0	346.0	29.0
TPA6132A2RTET	WQFN	RTE	16	250	190.5	212.7	31.8

RTE (S-PQFP-N16)

PLASTIC QUAD FLATPACK

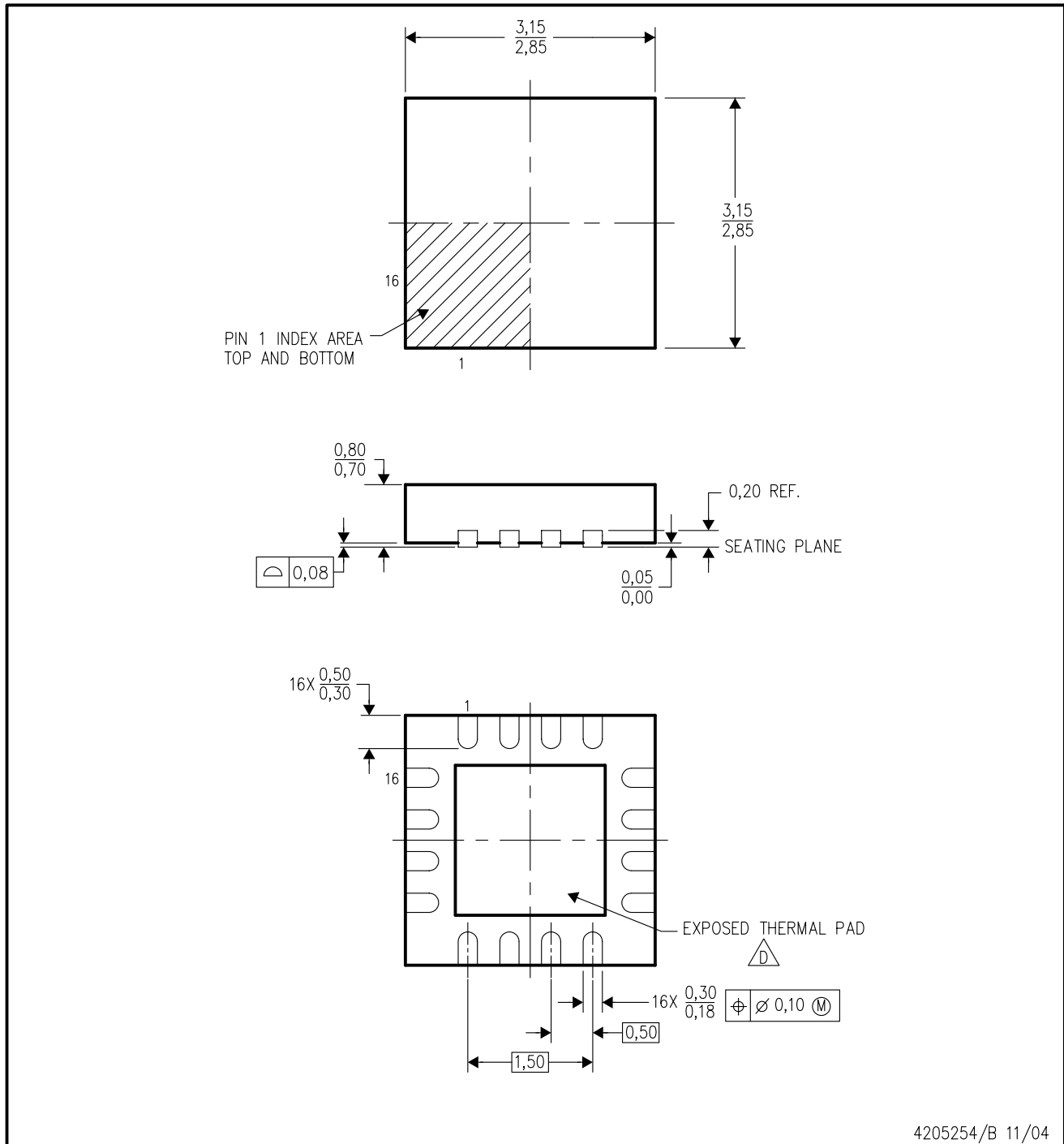

4205254/B 11/04

- NOTES:
- A. All linear dimensions are in millimeters. Dimensioning and tolerancing per ASME Y14.5M-1994.
 - B. This drawing is subject to change without notice.
 - C. Quad Flatpack, No-leads (QFN) package configuration.
 - $\triangle D$ The package thermal pad must be soldered to the board for thermal and mechanical performance. See the Product Data Sheet for details regarding the exposed thermal pad dimensions.
 - E. Falls within JEDEC MO-220.

THERMAL INFORMATION

This package incorporates an exposed thermal pad that is designed to be attached directly to an external heatsink. The thermal pad must be soldered directly to the printed circuit board (PCB). After soldering, the PCB can be used as a heatsink. In addition, through the use of thermal vias, the thermal pad can be attached directly to the appropriate copper plane shown in the electrical schematic for the device, or alternatively, can be attached to a special heatsink structure designed into the PCB. This design optimizes the heat transfer from the integrated circuit (IC).

For information on the Quad Flatpack No-Lead (QFN) package and its advantages, refer to Application Report, QFN/SON PCB Attachment, Texas Instruments Literature No. SLUA271. This document is available at www.ti.com.

The exposed thermal pad dimensions for this package are shown in the following illustration.

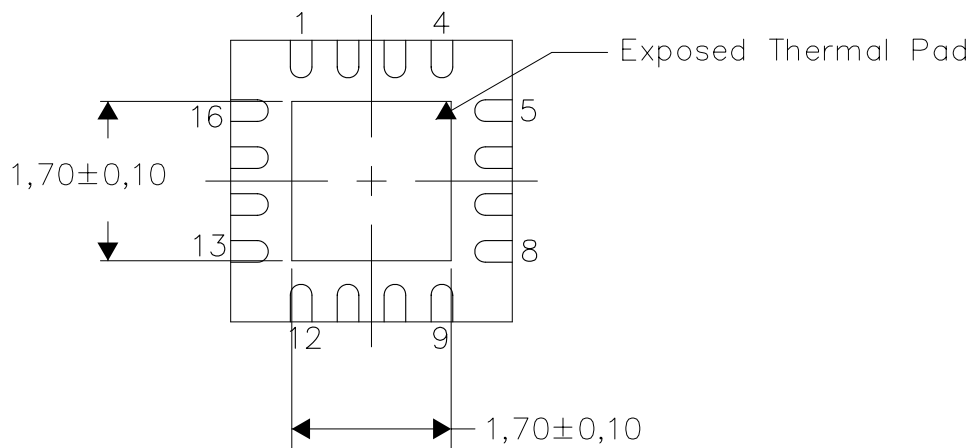

Bottom View

NOTE: All linear dimensions are in millimeters

Exposed Thermal Pad Dimensions

RTE (S-PWQFN-N16)

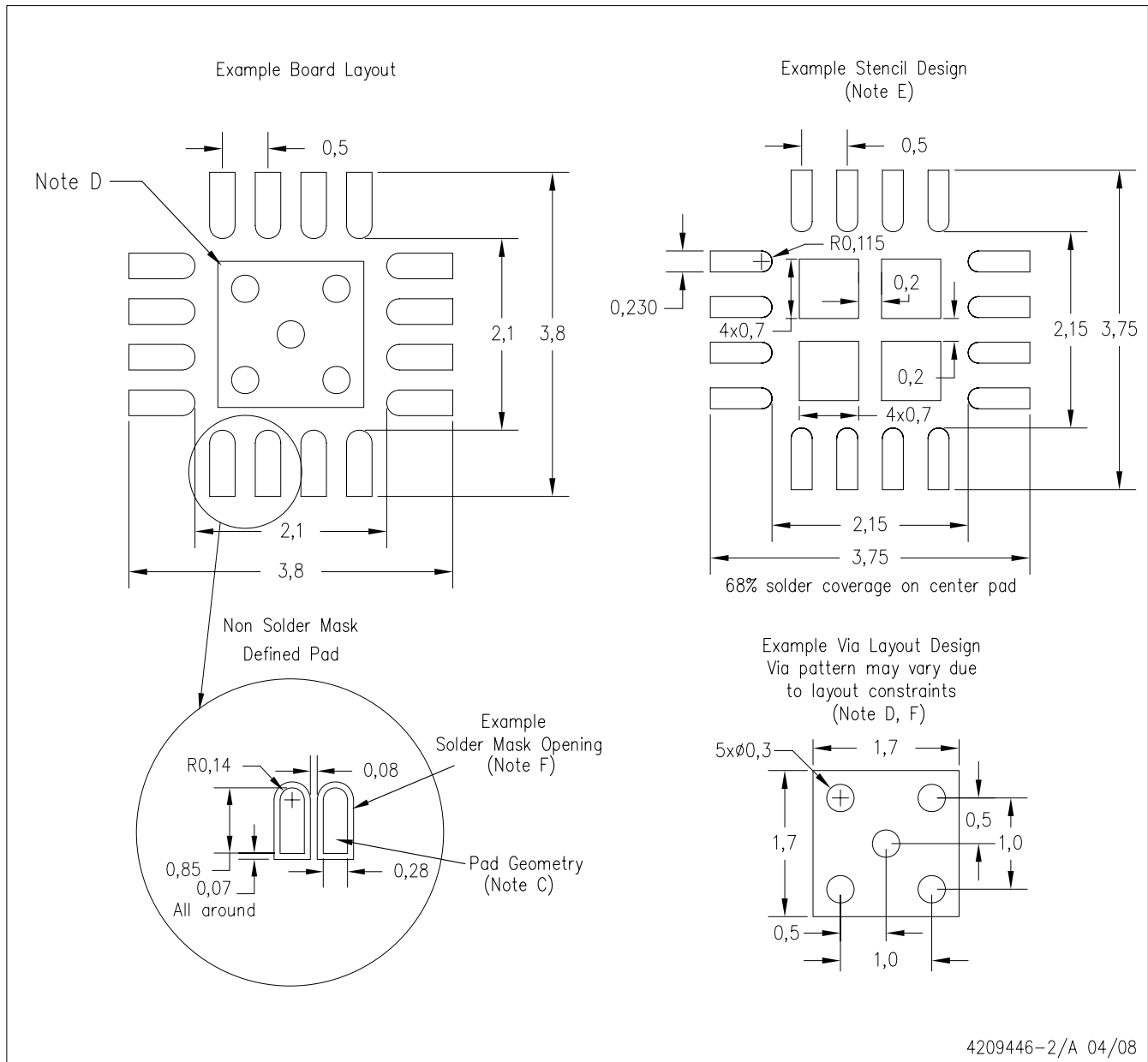

- NOTES:
- A. All linear dimensions are in millimeters.
 - B. This drawing is subject to change without notice.
 - C. Publication IPC-7351 is recommended for alternate designs.
 - D. This package is designed to be soldered to a thermal pad on the board. Refer to Application Note, Quad Flat-Pack Packages, Texas Instruments Literature No. SCBA017, SLUA271, and also the Product Data Sheets for specific thermal information, via requirements, and recommended board layout. These documents are available at www.ti.com <<http://www.ti.com>>.
 - E. Laser cutting apertures with trapezoidal walls and also rounding corners will offer better paste release. Customers should contact their board assembly site for stencil design recommendations. Refer to IPC 7525 for stencil design considerations.
 - F. Customers should contact their board fabrication site for minimum solder mask web tolerances between signal pads.

TAPE AND REEL INFORMATION

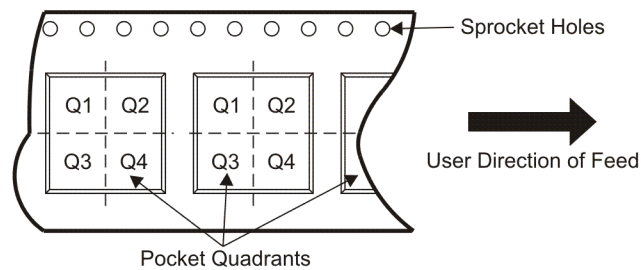
QUADRANT ASSIGNMENTS FOR PIN 1 ORIENTATION IN TAPE

*All dimensions are nominal

Device	Package Type	Package Drawing	Pins	SPQ	Reel Diameter (mm)	Reel Width W1 (mm)	A0 (mm)	B0 (mm)	K0 (mm)	P1 (mm)	W (mm)	Pin1 Quadrant
TPA6132A2RTER	WQFN	RTE	16	3000	330.0	12.4	3.3	3.3	1.1	8.0	12.0	Q2
TPA6132A2RTET	WQFN	RTE	16	250	180.0	12.4	3.3	3.3	1.1	8.0	12.0	Q2

TAPE AND REEL BOX DIMENSIONS



*All dimensions are nominal

Device	Package Type	Package Drawing	Pins	SPQ	Length (mm)	Width (mm)	Height (mm)
TPA6132A2RTER	WQFN	RTE	16	3000	346.0	346.0	29.0
TPA6132A2RTET	WQFN	RTE	16	250	190.5	212.7	31.8

IMPORTANT NOTICE

Texas Instruments Incorporated and its subsidiaries (TI) reserve the right to make corrections, modifications, enhancements, improvements, and other changes to its products and services at any time and to discontinue any product or service without notice. Customers should obtain the latest relevant information before placing orders and should verify that such information is current and complete. All products are sold subject to TI's terms and conditions of sale supplied at the time of order acknowledgment.

TI warrants performance of its hardware products to the specifications applicable at the time of sale in accordance with TI's standard warranty. Testing and other quality control techniques are used to the extent TI deems necessary to support this warranty. Except where mandated by government requirements, testing of all parameters of each product is not necessarily performed.

TI assumes no liability for applications assistance or customer product design. Customers are responsible for their products and applications using TI components. To minimize the risks associated with customer products and applications, customers should provide adequate design and operating safeguards.

TI does not warrant or represent that any license, either express or implied, is granted under any TI patent right, copyright, mask work right, or other TI intellectual property right relating to any combination, machine, or process in which TI products or services are used. Information published by TI regarding third-party products or services does not constitute a license from TI to use such products or services or a warranty or endorsement thereof. Use of such information may require a license from a third party under the patents or other intellectual property of the third party, or a license from TI under the patents or other intellectual property of TI.

Reproduction of TI information in TI data books or data sheets is permissible only if reproduction is without alteration and is accompanied by all associated warranties, conditions, limitations, and notices. Reproduction of this information with alteration is an unfair and deceptive business practice. TI is not responsible or liable for such altered documentation. Information of third parties may be subject to additional restrictions.

Resale of TI products or services with statements different from or beyond the parameters stated by TI for that product or service voids all express and any implied warranties for the associated TI product or service and is an unfair and deceptive business practice. TI is not responsible or liable for any such statements.

TI products are not authorized for use in safety-critical applications (such as life support) where a failure of the TI product would reasonably be expected to cause severe personal injury or death, unless officers of the parties have executed an agreement specifically governing such use. Buyers represent that they have all necessary expertise in the safety and regulatory ramifications of their applications, and acknowledge and agree that they are solely responsible for all legal, regulatory and safety-related requirements concerning their products and any use of TI products in such safety-critical applications, notwithstanding any applications-related information or support that may be provided by TI. Further, Buyers must fully indemnify TI and its representatives against any damages arising out of the use of TI products in such safety-critical applications.

TI products are neither designed nor intended for use in military/aerospace applications or environments unless the TI products are specifically designated by TI as military-grade or "enhanced plastic." Only products designated by TI as military-grade meet military specifications. Buyers acknowledge and agree that any such use of TI products which TI has not designated as military-grade is solely at the Buyer's risk, and that they are solely responsible for compliance with all legal and regulatory requirements in connection with such use.

TI products are neither designed nor intended for use in automotive applications or environments unless the specific TI products are designated by TI as compliant with ISO/TS 16949 requirements. Buyers acknowledge and agree that, if they use any non-designated products in automotive applications, TI will not be responsible for any failure to meet such requirements.

Following are URLs where you can obtain information on other Texas Instruments products and application solutions:

Products		Applications	
Amplifiers	amplifier.ti.com	Audio	www.ti.com/audio
Data Converters	dataconverter.ti.com	Automotive	www.ti.com/automotive
DLP® Products	www.dlp.com	Communications and Telecom	www.ti.com/communications
DSP	dsp.ti.com	Computers and Peripherals	www.ti.com/computers
Clocks and Timers	www.ti.com/clocks	Consumer Electronics	www.ti.com/consumer-apps
Interface	interface.ti.com	Energy	www.ti.com/energy
Logic	logic.ti.com	Industrial	www.ti.com/industrial
Power Mgmt	power.ti.com	Medical	www.ti.com/medical
Microcontrollers	microcontroller.ti.com	Security	www.ti.com/security
RFID	www.ti-rfid.com	Space, Avionics & Defense	www.ti.com/space-avionics-defense
RF/IF and ZigBee® Solutions	www.ti.com/lprf	Video and Imaging	www.ti.com/video
		Wireless	www.ti.com/wireless-apps

Mailing Address: Texas Instruments, Post Office Box 655303, Dallas, Texas 75265
Copyright © 2010, Texas Instruments Incorporated