

REVISION BN

DO NOT SCALE FROM THIS PRINT

UNLESS OTHERWISE NOTED DIMENSIONS ARE IN INCHES [MILLIMETERS ARE IN BRACKETS]		TOLERANCES ARE:
ONE PLACE DECIMALS ± .1[.254]	THREE PLACE DECIMALS ± .005[.127]	ANGLES ± 2°
TWO PLACE DECIMALS ± .01[.25]	FOUR PLACE DECIMALS ± .0020[.051]	

TITLE: LOW PROFILE
.050 x .050
DOUBLE ROW ASM

DWG NO: CLP-1XX-XX-XXX-D-XX
SHEET 1 OF 2

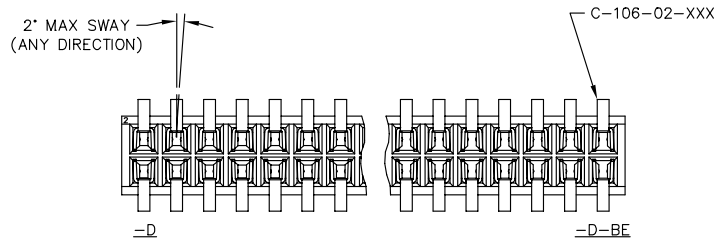
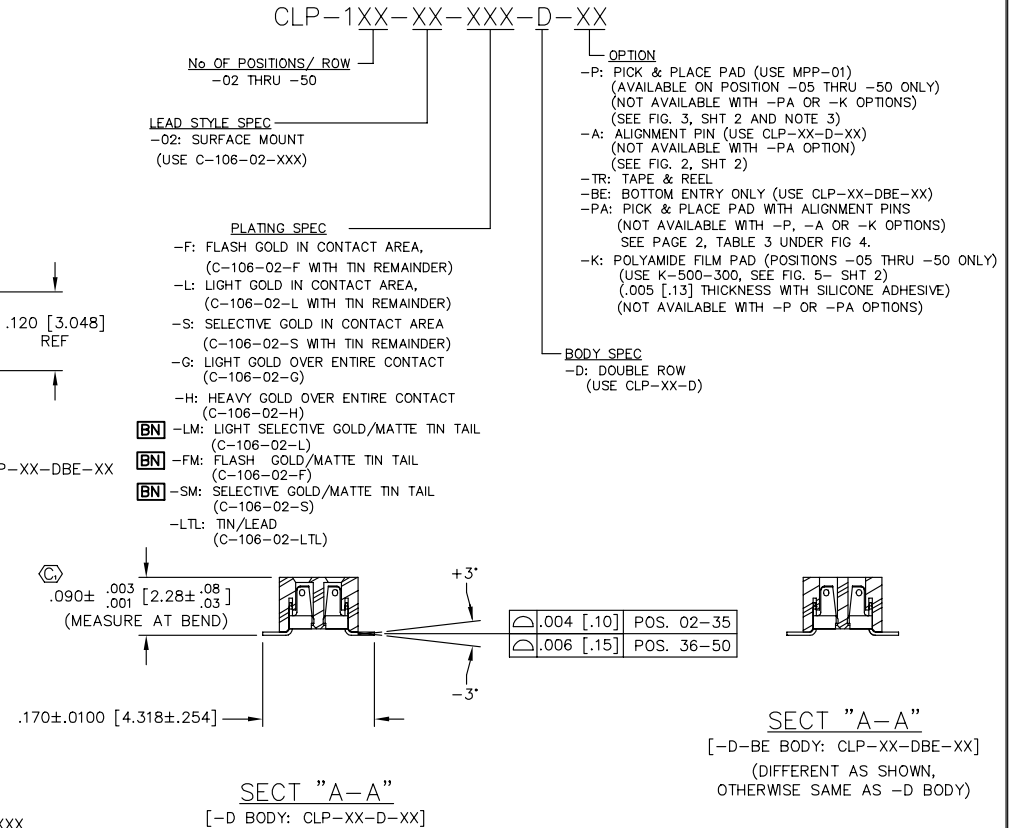
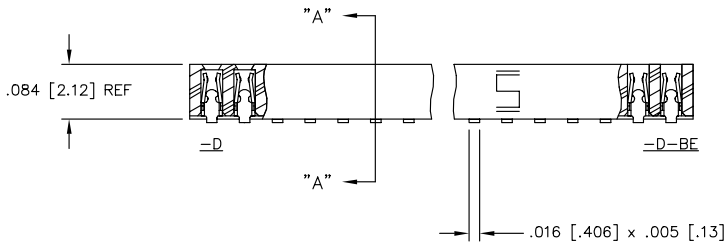
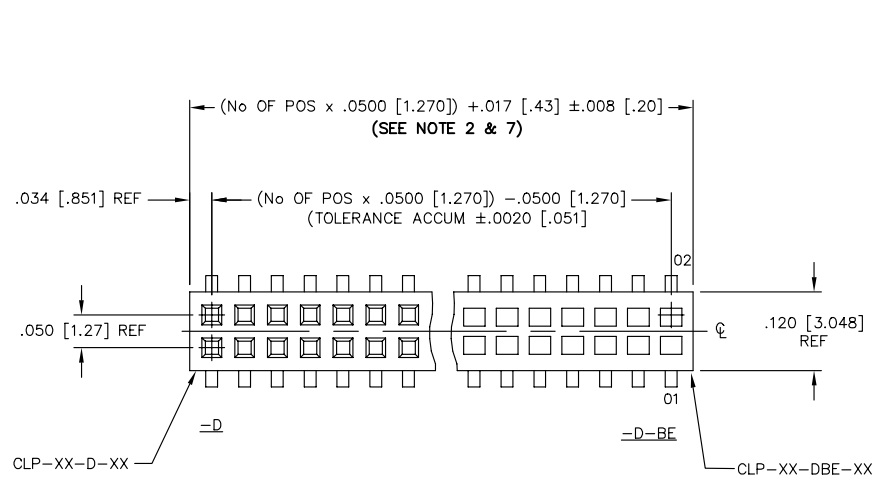

NOTES:

1. MINIMUM PUSHOUT FORCE: .5 lb (8 OZ).
2. ONE POSITION WILL BE LOST FOR EVERY CUT MADE ON A SOCKET STRIP: CUT FLASH TO BE .010 [.25] MAX WITH NO FLASH ALLOWED IN HOLES OR EXTENDING BELOW LEADS.
3. TUBE PACKAGE POSITIONS 5 - 50 ONLY. POSITIONS 2-4 ARE TO BE LAYER PACKAGED.
4. SHEAR TAILS TO DIMENSIONS SHOWN: .003 [.08] MAX BURR.
5. PARTS TO BE SYMMETRICAL ABOUT CL WITHIN ±.0015.
6. Ⓞ REPRESENTS A CRITICAL DIMENSION.
7. ENDWALL AFTER CUTTING: .0185±.0025 [.470±.064]
8. VOID CORES MAY NOT BE PRESENT.
9. NOTE DELETED.

PROPRIETARY NOTE
THIS DOCUMENT CONTAINS INFORMATION CONFIDENTIAL AND PROPRIETARY TO SAMTEC INC. AND SHALL NOT BE REPRODUCED OR TRANSMITTED TO OTHER DOCUMENTS OR DISCLOSED TO OTHERS OR USED FOR ANY PURPOSE OTHER THAN THAT FOR WHICH IT WAS OBTAINED WITHOUT THE EXPRESSED WRITTEN CONSENT OF SAMTEC INC.

FIG. 1

MATERIAL:
BODY: LCP
COLOR: BLACK
CONTACT: PHOSPHOR BRONZE

samtec

EXISPROD\ASSEMBLY\050
CLP-DASM
520 PARK EAST BLVD. NEW ALBANY, INDIANA 47150
PHONE (812) 944-6733 P.O. BOX 1147
CODE 55322

PLOT SCALE: .150/ DIMSCALE: .125

MADE BY: PURVIS 1-31-94

SHEET 1 OF 2
CLP-1XX-XX-XXX-D-XX