

LOC		DIST		P		F		ZONE		LTR		REVISIONS		DATE	APPD	
CM	53												D	REV PER EC 0730-0212-94	11-22-94	JH RS

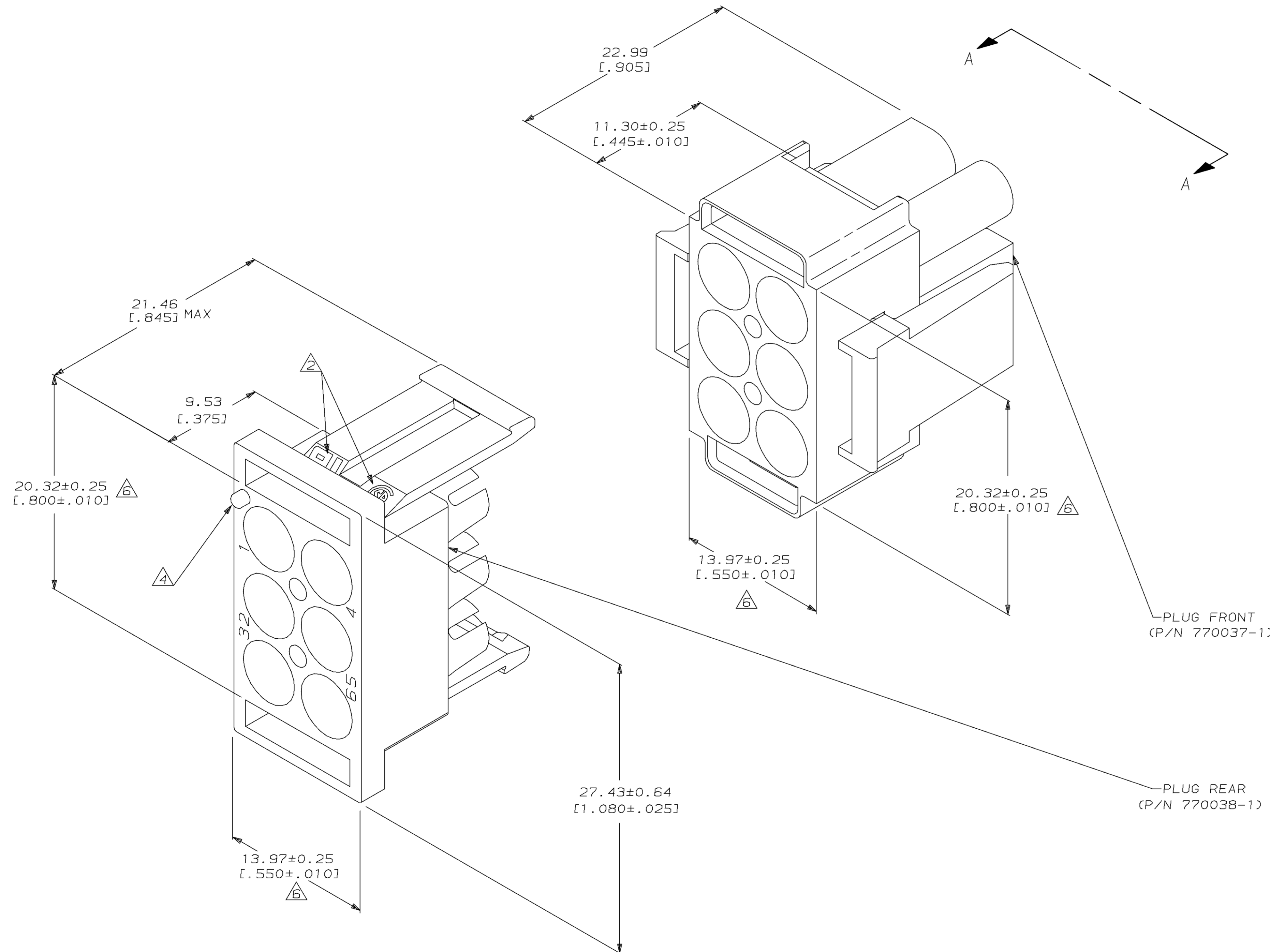

- BULK PACKAGED, UNASSEMBLED.
- APPROVAL AGENCY LOGO LOCATED APPROXIMATELY AS SHOWN.
- AMP LOGO LOCATED THIS SURFACE.
- CIRCUIT NUMBER ONE IDENTIFICATION BUTTON AND CIRCUIT IDENTIFICATION NUMBERS ARE EACH LOCATED ADJACENT TO THE APPROPRIATE CIRCUIT CAVITIES.
- NEW MOLD CONSTRUCTION PROVIDES MATERIAL REDUCTION CORING AT BASE OF SILOS WITH NO CORING AS OPTIONAL.
- DIMENSION INDICATED IS AS MOLDED. ADDITIONAL GROWTH DUE TO SUBSEQUENT MOISTURE ABSORPTION MAY OCCUR.

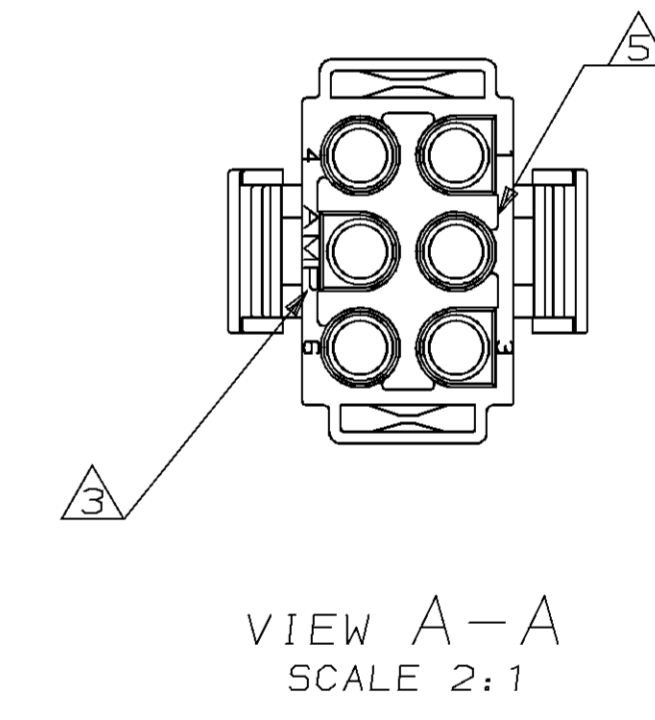

770020-1  
PART NUMBER

DO NOT SCALE PRINT. UNLESS SPECIFIED DIMENSIONS IN INCHES TOLERANCES ON:		DR 1-22-92 K. SALMON		PART NO	
1 DIMENSIONS	± .010	CHK 1-22-92 R. SWING		AMP INCORPORATED Harrisburg, Pa. 17105	
2 PLC DEC	± .005	APPD 1-22-92 M. TRULL			
3 ANGLES	± .005	APPD 1-22-92 M. TRULL		NAME PLUG HOUSING KIT, 6 CIRCUIT, UNIVERSAL MATE-N-LOK™ II	
MATERIAL NYLON, UL94V-0,		PRODUCT SPEC		SIZE <b>D</b>	FSCM NO 00779
FINISH		APPLICATION SPEC		SCALE 5:1	DRAWING NO 770020
		WEIGHT			SHEET 1 OF 1

