

注記 NOTES:

1. 使用材料 MATERIAL  
 ウェハー: 液晶ポリマー (LCP) ガラス充填 UL94V-0 (黒)  
 WAFER: LIQUID CRYSTAL POLYMER (GLASS FILLED)  
 UL94V-0 (COLOR: BLACK)  
 ピン: 黄銅 (t=0.12)  
 PIN: BRASS (t=0.12)  
 金具: リン青銅 (t=0.2)  
 FITTING NAIL: PHOSPHOR BRONZE (t=0.2)
2. メッキ仕様 PLATING  
 ピン PIN  
 金メッキ 0.2 マイクロメートル以上 (コンタクト部)  
 GOLD 0.2MICROMETER MINIMUM (CONTACT AREA)  
 金メッキ 0.4 マイクロメートル以下 (テール部)  
 GOLD 0.4MICROMETER MAXIMUM (TAIL AREA)  
 下地メッキ: ニッケルメッキ 1.5 マイクロメートル以上  
 UNDER PLATING: NICKEL 1.5MICROMETER MINIMUM  
 金具 FITTING NAIL  
 錫メッキ 1.0 マイクロメートル以上  
 TIN PLATING 1.0MICROMETER MINIMUM  
 下地メッキ: ニッケルメッキ 1.0 マイクロメートル以上  
 UNDER PLATING: NICKEL 1.0MICROMETER MINIMUM

3. (全極数/2) = 偶数の場合に適用。  
 APPLY FOR (CIRCUIT/2)=EVEN.
4. 嵌合相手: 51338シリーズ  
 MATE WITH: 51338 SERIES.
5. テール平坦度は、0.08以下  
 テール及び金具の平坦度は、0.1以下  
 TAIL COPLANARITY TO BE 0.08 MAXIMUM  
 TAIL AND FITTING NAIL COPLANARITY TO BE 0.1 MAXIMUM
6. 本製品は 55909-\*\*\*3 の鉛フリー品である。  
 THIS PRODUCT IS LEAD FREE OF 55909-\*\*\*3

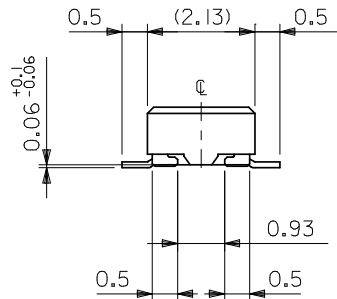
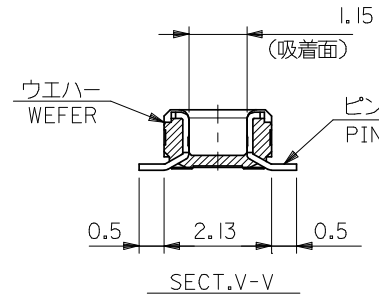

25.2	23.6	26.0	55909-1274	55909-1273	120
21.2	19.6	22.0	55909-1074	55909-1073	100
19.2	17.6	20.0	55909-0974	55909-0973	90
17.2	15.6	18.0	55909-0874	55909-0873	80
15.2	13.6	16.0	55909-0774	55909-0773	70
13.2	11.6	14.0	55909-0674	55909-0673	60
11.2	9.6	12.0	55909-0574	55909-0573	50
9.2	7.6	10.0	55909-0474	55909-0473	40
8.0	6.4	8.8	55909-3474	55909-3473	34
7.2	5.6	8.0	55909-0374	55909-0373	30
6.4	4.8	7.2	55909-2674	55909-2673	26
6.0	4.4	6.8	55909-2474	55909-2473	24
5.6	4.0	6.4	55909-2274	55909-2273	22
5.2	3.6	6.0	55909-0274	55909-0273	20
3.6	2.0	4.4	55909-9974	55909-9973	12
C	B	A	EMBOSSED TAPE PKG. ORDER No. オーダー番号	MATERIAL No.	CKT.

REVISED EC NO.: J2009-0301 DRWN: MWABEI 2008/08/27 CHKD: THARUYAMA 2008/08/28 APPR: NUKITA 2008/08/28	GENERAL TOLERANCES (UNLESS SPECIFIED)		DIMENSION STYLE MM ONLY		SCALE ---	DESIGN UNITS METRIC	55909-***73	MODEL NO.
	10 UNDER	±0.2	DRAWN BY HSHIMABUKURO	DATE 2004/02/20	TITLE 0.4 B-TO-B CONN. PLUG ASSY (HGT=1.5) WITH NAIL -LEAD FREE-		THIRD ANGLE PROJECTION	
	10 OVER 30 UNDER	±0.25	CHECKED BY K. TOJO	DATE 2004/02/20	APPROVED BY M. SASAO		DOCUMENT NO. SD-55909-003	
	30 OVER	±0.3	MATERIAL NO. SEE TABLE		SHEET NO. 1 OF 2		MATERIAL No. 55909-***73	
ANGULAR ±1/2 °		DRAFT WHERE APPLICABLE MUST REMAIN WITHIN DIMENSIONS		THIS DRAWING CONTAINS INFORMATION THAT IS PROPRIETARY TO MOLEX INCORPORATED AND SHOULD NOT BE USED WITHOUT WRITTEN PERMISSION				

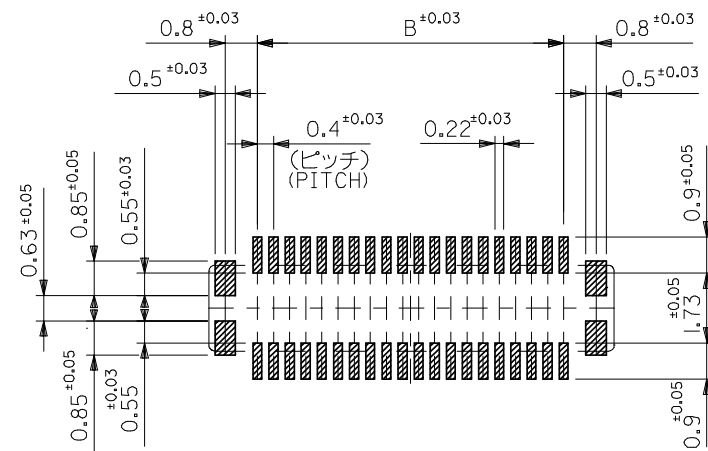
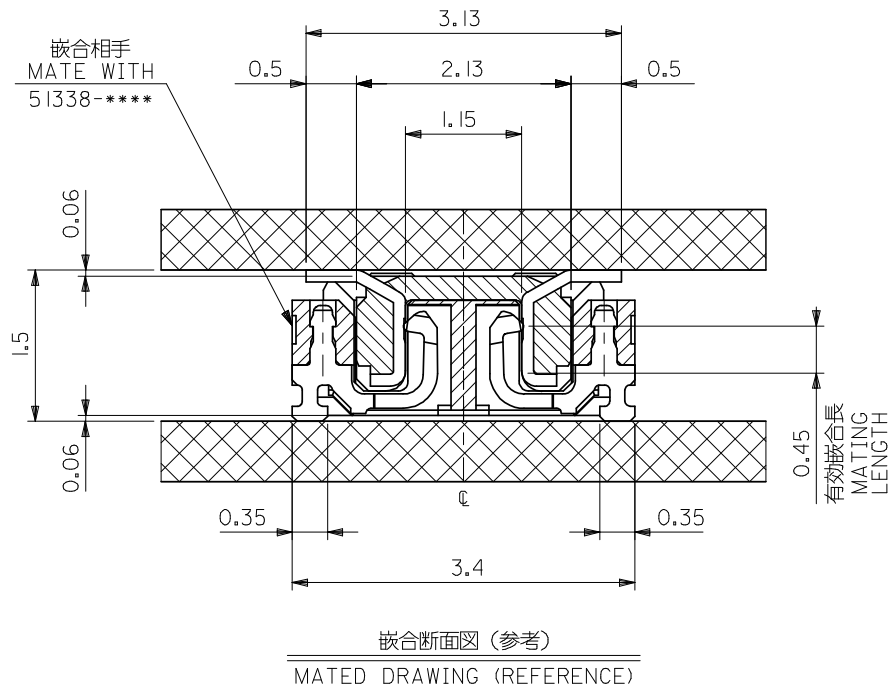

参考基板レイアウト (マウント面)  
P.C. BOARD PATTERN DIMENSION,  
(REFERENCE)  
(MOUNTING AREA)

REVISED EC NO.: J2009-0301 DRAWN: MABEI 2008/08/27 CHKD: THARUYAMA 2008/08/28 APPR: NUKITA 2008/08/28	GENERAL TOLERANCES (UNLESS SPECIFIED)		DIMENSION STYLE MM ONLY	SCALE ---	DESIGN UNITS METRIC	55909-**73	MODEL NO.
	10 UNDER	±0.2	DRAWN BY HSHIMABUKURO	DATE 2004/02/20	TITLE	0.4 B-TO-B CONN. PLUG ASSY (HGT=1.5) WITH NAIL -LEAD FREE-	
	10 OVER 30 UNDER	±0.25	CHECKED BY K. TOJO	DATE 2004/02/20		MOLEX INCORPORATED	
	30 OVER	±0.3	APPROVED BY M. SASAO	DATE 2004/02/20		DOCUMENT NO. SD-55909-003	SHEET NO. 2 OF 2
	ANGULAR ±3 °	DRAFT WHERE APPLICABLE MUST REMAIN WITHIN DIMENSIONS	MATERIAL NO. SEE SHEET 1	THIS DRAWING CONTAINS INFORMATION THAT IS PROPRIETARY TO MOLEX INCORPORATED AND SHOULD NOT BE USED WITHOUT WRITTEN PERMISSION			

NOTES

- 製品詳細寸法については製品単体図面を参照下さい。  
RE DETAILED DIMENSION, SEE PRODUCT DRAWING.
- 梱包数量：2500個/リール  
NUMBER OF CONNECTORS : 2500PCS/REEL
- リードテープ長さ LEAD TAPE LENGTH

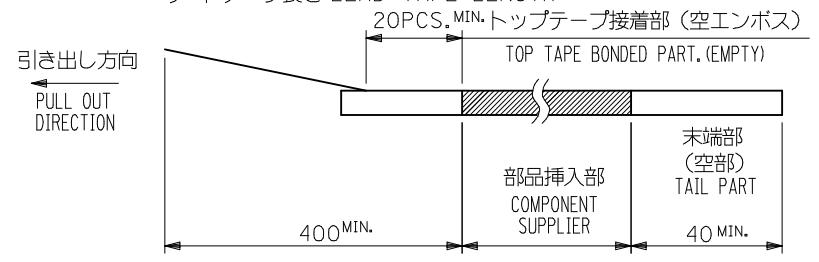
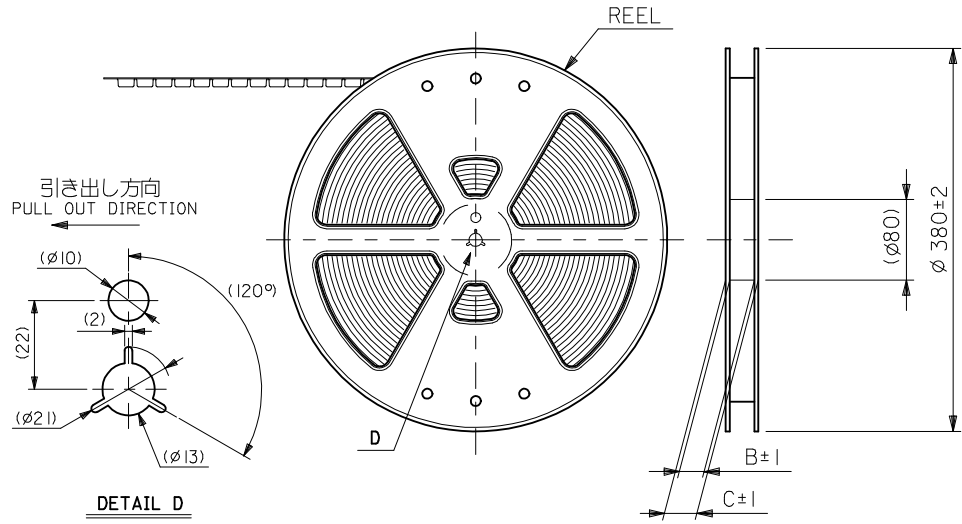

- 材料 MATERIAL  
キャリアテープ (CARRIER TAPE) : ポリプロピレン (POLYPROPYLENE)  
トップテープ (TOPTAPE) : PET , PE , PEF  
リール (REEL) : ポリスチレン (PS) <リサイクル材を含む>  
POLYSTYRENE (PS) <RECYCLE MATERIAL CONTAINED>
- 本製品は 55909-\*\*\*4 の鉛フリー品である。  
THIS PRODUCT IS LEAD FREE OF 55909-\*\*\*\*4

REVISED EC NO: DRWN: YOSHIDAM 2008/10/27 CHKD: THARUYAMA 2009/03/23 APPR: THARUYAMA 2009/03/25	GENERAL TOLERANCES (UNLESS SPECIFIED)		DIMENSION STYLE MM ONLY	SCALE ---	55909-**74	MODEL NO.
	10 UNDER	±0.2	DRAWN BY H. SHIMAB	DATE 2004/02/20	THIRD ANGLE PROJECTION	
	10 OVER 30 UNDER	±0.25	CHECKED BY K. TOJO	DATE 2004/02/20	0.4 B-T-O-B CONN PLUG ASSY(HGT=1.5) EMBSTP PKG -LEAD FREE-	
	30 OVER	±0.3	APPROVED BY M. SASAO	DATE 2004/02/20	MOLEX INCORPORATED	
REV	DESCRIPTION	ANGULAR ±3 °	MATERIAL NO. SEE CHART	DOCUMENT NO. SD-55909-004	SHEET NO. 1 OF 5	
		DRAFT WHERE APPLICABLE MUST REMAIN WITHIN DIMENSIONS	THIS DRAWING CONTAINS INFORMATION THAT IS PROPRIETARY TO MOLEX INCORPORATED AND SHOULD NOT BE USED WITHOUT WRITTEN PERMISSION			

引き出し方向  
PULL OUT DIRECTION

トップテープ  
TOP TAPE

55909-\*\*73

0.5±0.05  
(2.6)

SECT. Y-Y

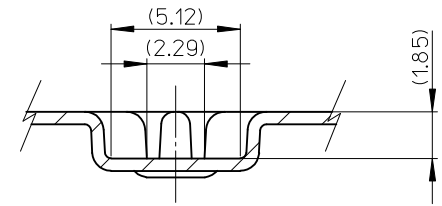
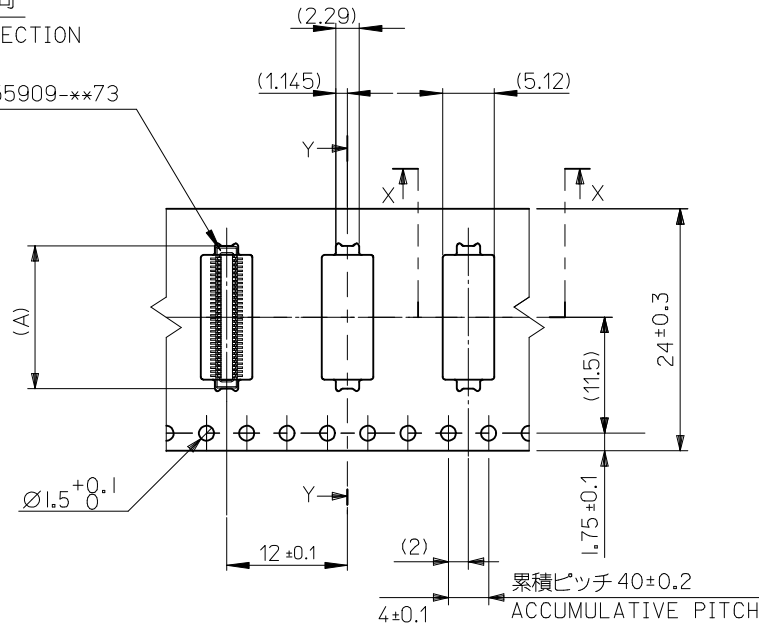

24	29.4	25.4	14.16	55909-0674	60		
			12.16	55909-0574	50		
			10.16	55909-0474	40		
			8.96	55909-3474	34		
			8.16	55909-0374	30		
			7.36	55909-2674	26		
			6.96	55909-2474	24		
			6.56	55909-2274	22		
			6.16	55909-0274	20		
キャリアテープ幅 CARRIER TAPE WIDTH			C	B	(A)	MATERIAL NO.	CKT

REVISED	EC NO:	2008/10/27	GENERAL TOLERANCES (UNLESS SPECIFIED)		DIMENSION STYLE	SCALE	DESIGN UNITS	MODEL NO.	
	DRWN:	YOSHIDAM	10 UNDER	±0.2	MM ONLY	---	METRIC	55909-**74	
	CHKD:	THARUYAMA	10 OVER 30 UNDER	±0.25				THIRD ANGLE PROJECTION	
	APPR:	THARUYAMA	30 OVER	±0.3				0.4 B-T-O-B CONN PLUG ASSY(HGT=1.5) EMBSTP PKG -LEAD FREE-	
REV	DESCRIPTION	ANGULAR	±3 °	DRAFT WHERE APPLICABLE MUST REMAIN WITHIN DIMENSIONS	DRAWN BY	DATE	TITLE	MOLEX INCORPORATED	
					H. SHIMAB	2004/02/20		SD-55909-004	
					CHECKED BY	DATE		SHEET NO.	
					K. TOJO	2004/02/20		2 OF 5	
					APPROVED BY	DATE			
					M. SASAO	2004/02/20			
					MATERIAL NO.				
					SIZE		THIS DRAWING CONTAINS INFORMATION THAT IS PROPRIETARY TO MOLEX INCORPORATED AND SHOULD NOT BE USED WITHOUT WRITTEN PERMISSION		
					A3				

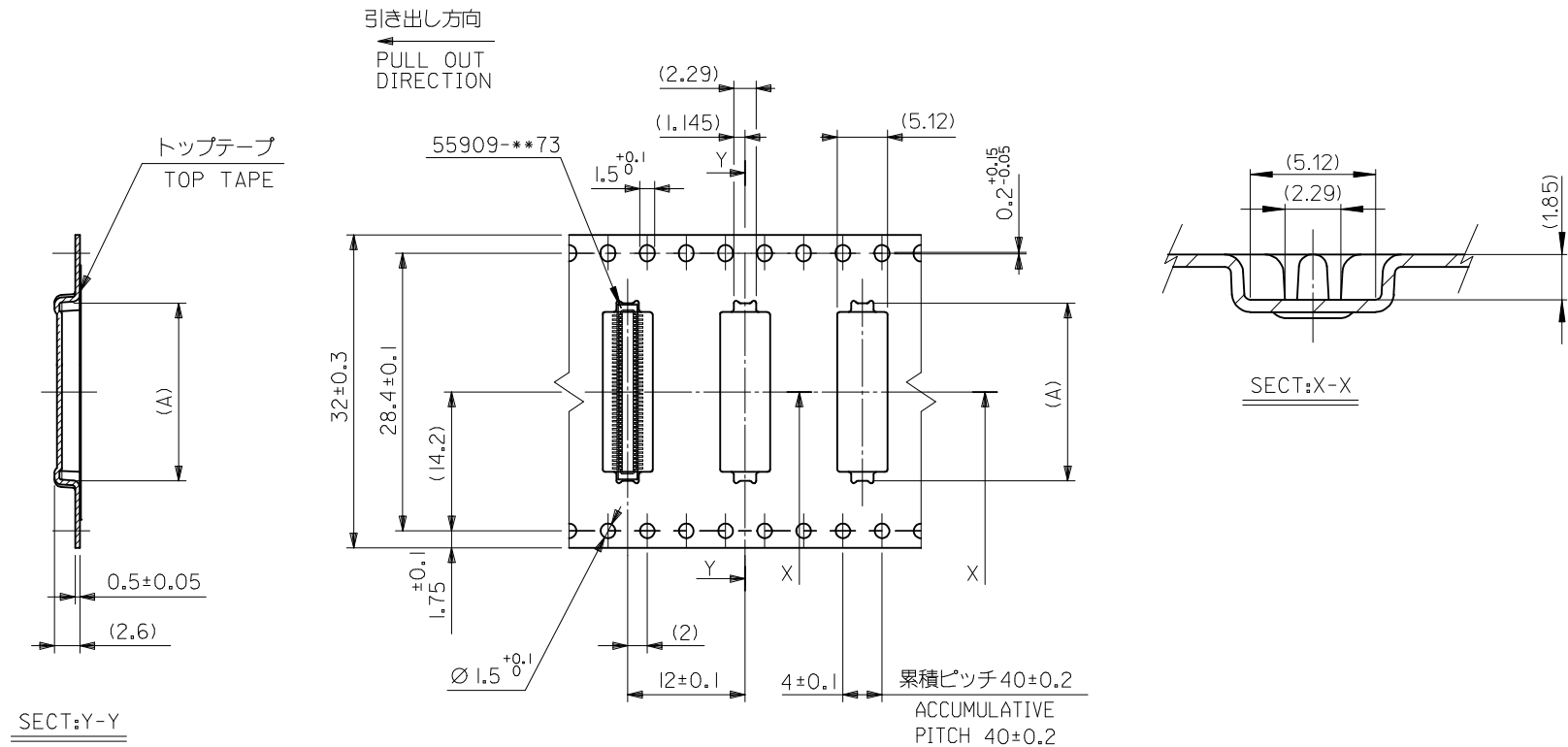

32mm幅キャリアテープ  
32mm WIDTH CARRIER TAPE

32	37.4	33.4	19.16	55909-0974	90
			18.16	55909-0874	80
			16.16	55909-0774	70
キャリアテープ幅 CARRIER TAPE WIDTH	C	B	(A)	MATERIAL NO.	極数 CKT.

REVISED EC NO: DRWN: YOSHIDAM CHKD: THARUYAMA APPR: THARUYAMA	2008/10/27	GENERAL TOLERANCES (UNLESS SPECIFIED)		DIMENSION STYLE MM ONLY	SCALE ---	DESIGN UNITS METRIC	55909-**74	MODEL NO.
	2009/03/23	10 UNDER	±0.2	DRAWN BY H. SHIMAB	DATE 2004/02/20	TITLE 0.4 B-T0-B CONN PLUG ASSY(HGT=1.5) EMBSTP PKG -LEAD FREE-		
	2009/03/25	10 OVER 30 UNDER	±0.25	CHECKED BY K. TOJO	DATE 2004/02/20	MOLEX INCORPORATED		
		30 OVER	±0.3	APPROVED BY M. SASAO	DATE 2004/02/20	DOCUMENT NO. SD-55909-004		
		ANGULAR ±3 °	DRAFT WHERE APPLICABLE MUST REMAIN WITHIN DIMENSIONS	MATERIAL NO.	SEE CHART			SHEET NO. 3 OF 5
				SIZE A3	THIS DRAWING CONTAINS INFORMATION THAT IS PROPRIETARY TO MOLEX INCORPORATED AND SHOULD NOT BE USED WITHOUT WRITTEN PERMISSION			

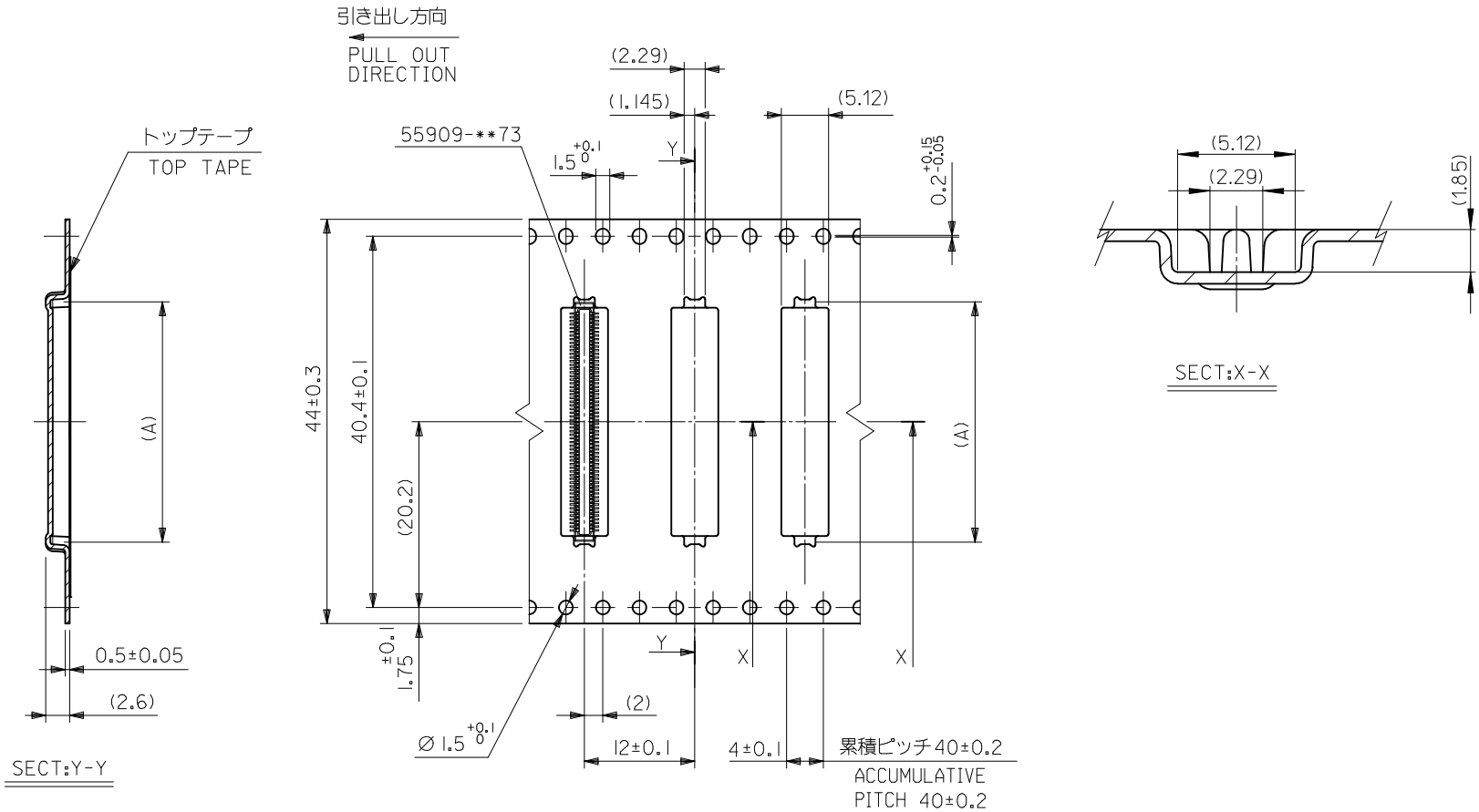

4.4mm幅キャリアテープ  
44mm WIDTH CARRIER TAPE

44	49.4	45.4	22.16	55909-1074	100
キャリアテープ幅 CARRIER TAPE WIDTH	C	B	(A)	MATERIAL NO.	極数 CKT.

REVISED EC NO: DRWN: YOSHIDAM 2008/10/27 CHKD: THARUYAMA 2009/03/23 APPR: THARUYAMA 2009/03/25	GENERAL TOLERANCES (UNLESS SPECIFIED)		DIMENSION STYLE MM ONLY	SCALE ---	DESIGN UNITS METRIC	55909-**74	MODEL NO.
	10 UNDER	±0.2	DRAWN BY H. SHIMAB	DATE 2004/02/20	TITLE 0.4 B-T0-B CONN PLUG ASSY(HGT=1.5) EMBSTP PKG -LEAD FREE-		
	10 OVER 30 UNDER	±0.25	CHECKED BY K. TOJO	DATE 2004/02/20	MOLEX INCORPORATED		
	30 OVER	±0.3	APPROVED BY M. SASAO	DATE 2004/02/20	DOCUMENT NO. SD-55909-004		
REV	DESCRIPTION	ANGULAR ±3 °	MATERIAL NO.	SEE CHART		SHEET NO. 4 OF 5	
		DRAFT WHERE APPLICABLE MUST REMAIN WITHIN DIMENSIONS	THIS DRAWING CONTAINS INFORMATION THAT IS PROPRIETARY TO MOLEX INCORPORATED AND SHOULD NOT BE USED WITHOUT WRITTEN PERMISSION				

引き出し方向  
PULL OUT DIRECTION

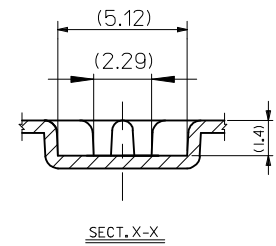
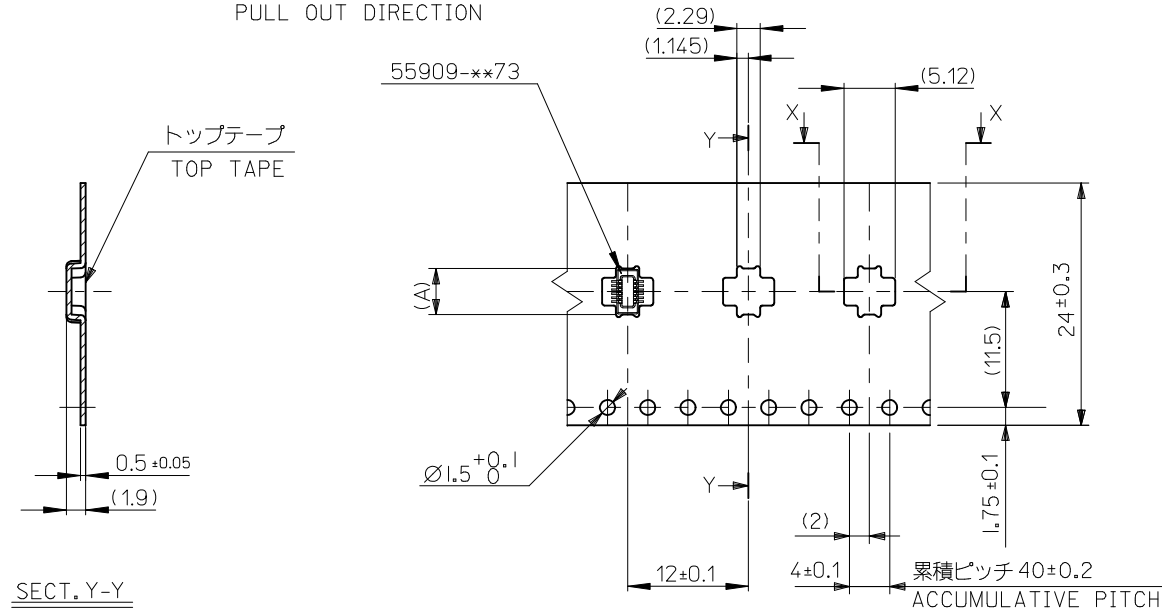

SECT. Y-Y

24	29.4	25.4	4.56	55909-9974	12
キャリアテープ幅 CARRIER TAPE WIDTH	C	B	(A)	MATERIAL NO.	CKT

55909-**74		MODEL NO.
DESIGN UNITS		THIRD ANGLE PROJECTION
METRIC		

REVISED	EC NO:	2008/10/27	GENERAL TOLERANCES (UNLESS SPECIFIED)
	DRWN:	YOSHIDAM	10 UNDER ± 0.2
	CHKD:	THARUYAMA	10 OVER 30 UNDER ± 0.25
	APPR:	THARUYAMA	30 OVER ± 0.3
REV	DESCRIPTION	ANGULAR ± 3 °	DRAFT WHERE APPLICABLE MUST REMAIN WITHIN DIMENSIONS

DIMENSION STYLE		SCALE
MM ONLY		---
DRAWN BY	DATE	TITLE
H. SHIMAB	2004/02/20	0.4 B-T-O-B CONN PLUG ASSY(HGT=1.5) EMBSTP PKG -LEAD FREE-
CHECKED BY	DATE	
K. TOJO	2004/02/20	MOLEX INCORPORATED
APPROVED BY	DATE	
M. SASAO	2004/02/20	DOCUMENT NO.
MATERIAL NO.	SEE CHART	
SIZE	THIS DRAWING CONTAINS INFORMATION THAT IS PROPRIETARY TO MOLEX INCORPORATED AND SHOULD NOT BE USED WITHOUT WRITTEN PERMISSION	
A3		

SD-55909-004		SHEET NO.
5 OF 5		