

NOTES

- MATERIAL - 12 GAUGE ALUMINUM COVERS
- PHILLIPS NICKEL PLATED SCREWS
- 0.064" THICK ALUMINUM PANELS
- SELF ADHESIVE RUBBER FEET

*ALSO AVAILABLE WITH VENTED TOP AND BOTTOM COVERS - #1402BV

*NOTE: FOR DETAILED FRONT AND REAR PANEL DRAWINGS SEE SHEET #2.
EXTRUSION DRAWING SEE SHEET #3.

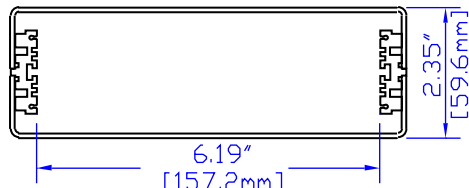

REAR VIEW

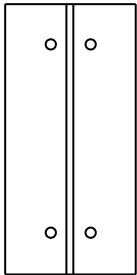

LEFT SIDE VIEW

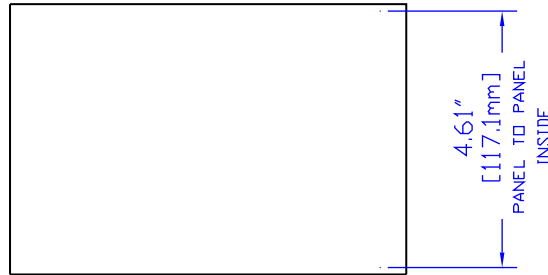

TOP VIEW

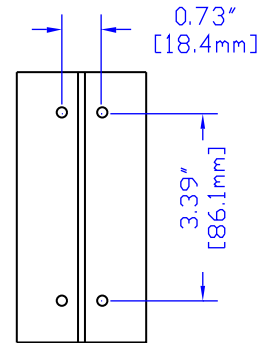

RIGHT SIDE VIEW

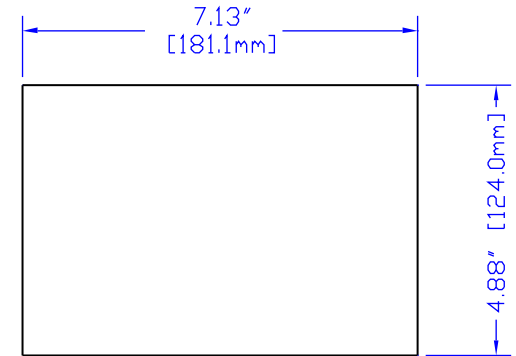

BOTTOM VIEW

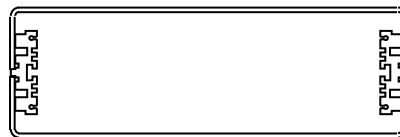

FRONT VIEW

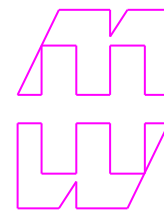

HAMMOND MANUFACTURING

1402B-Instrument

SHEET 1 OF 3

CANADA - PH (519) 886 7170 - FAX (519) 886 8311
U.S.A. - PH (716) 631 5700 - FAX (716) 631 1156