

© COPYRIGHT 1981 BY AMP INCORPORATED, HARRISBURG, PA. ALL INTERNATIONAL RIGHTS RESERVED. AMP INCORPORATED PRODUCTS COVERED BY U. S. AND FOREIGN PATENTS AND/OR PATENTS PENDING.

- 1 SHEET METAL SCREWS NOT SUPPLIED.
- 2 INSERT IS ATTACHED TO STRAIN RELIEF. AS AN ADDITIONAL ADJUSTMENT FOR SMALL WIRE BUNDLES, IT SHOULD BE CUT OFF AND POSITIONED AS SHOWN BY DOTTED LINES.
- 3 TWO REQUIRED PER CONNECTOR.
- 4 STYLE II DOES NOT INCLUDE INSERT.
- 5. DETACHABLE INSERT MAY SEPARATE FROM STRAIN RELIEF BODY DURING SHIPPING.

REVISIONS						
P	F	ZONE	LTR	DESCRIPTION	DATE	APPROVED
			E	REV PER EC 0730-0201-94	4-26-95	JH RS

-2 WAS CP83-3/591-2

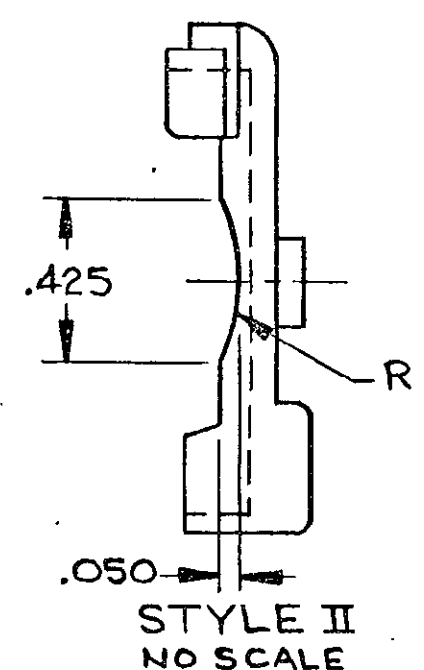
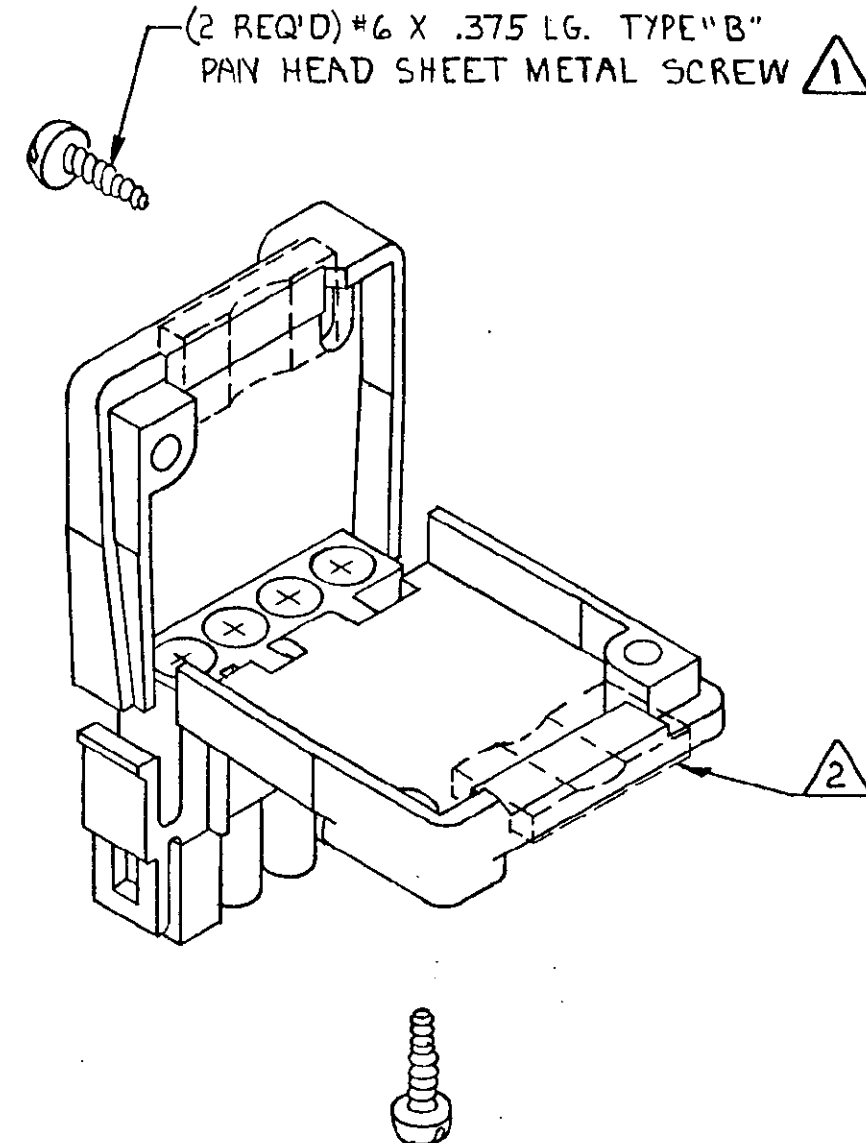
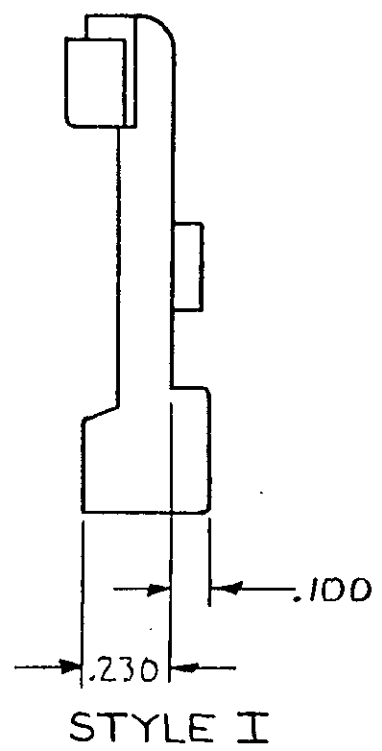
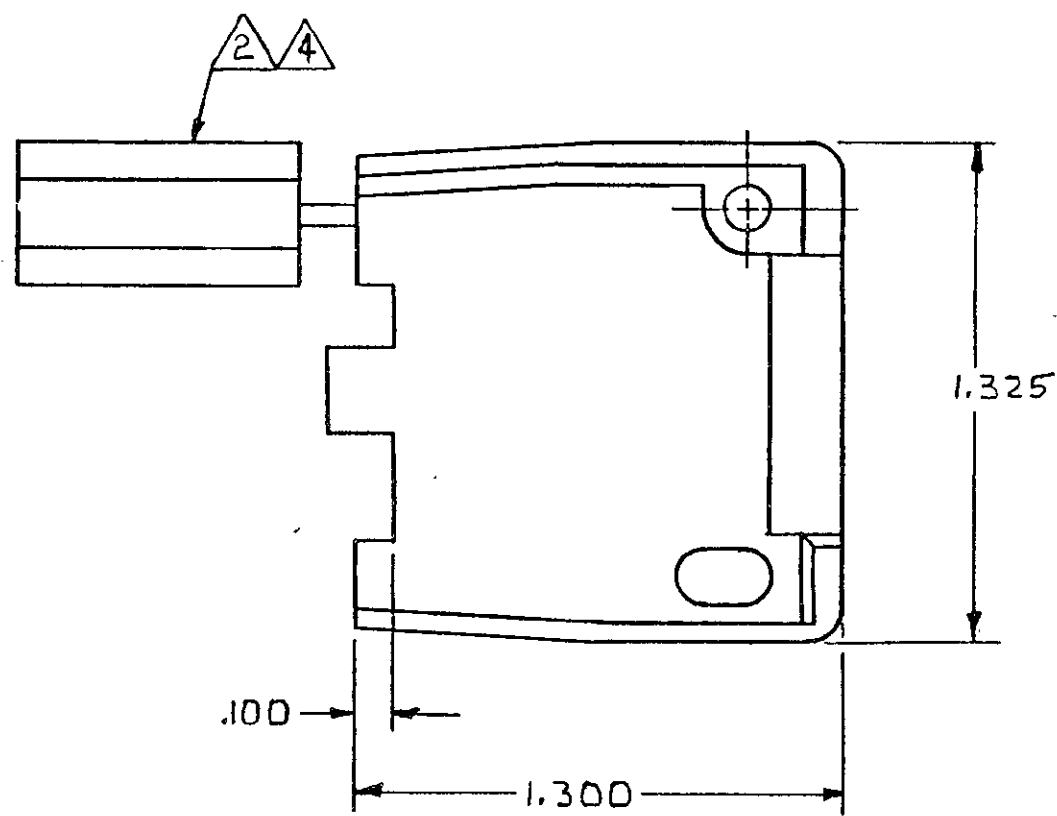
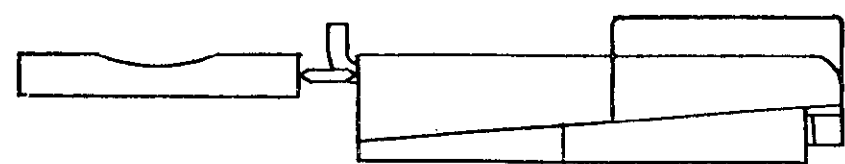

WIRE BUNDLE	
WITHOUT INSERT	MAX 4 @ .190 DIA
WITH INSERT	MIN 4 @ .040 DIA

UNLESS OTHERWISE SPECIFIED DIMENSIONS ARE IN INCHES. TOLERANCES ON: DECIMALS ± .015 ANGLES ± —	CONTRACT NO
MATERIAL	DR M. FEHER 1-22-81
COLOR	CHK J.S. Heide 1/28/81
	APPR J.C. Ford 1-28-81
	DSGN APPD
	OTHER APPD

NYLON94V-0	II	641776-2
NYLON94V-0	I	641776-1
MATERIAL	STYLE	PART NO
AMP AMP INCORPORATED Harrisburg, Pa.		
NAME STRAIN RELIEF AND INSERT, UNIVERSAL MATE-N-LOK™, 4 CIRCUIT		
SIZE	CODE IDENT NO	DRAWING NO
C	00779	641776
SCALE	SHEET 1 OF 1	
2-1		

641776