



## PARALLEL REAL-TIME CLOCK WITH CPU SUPERVISOR AND EXTERNAL SRAM NONVOLATILE MEMORY BACKUP

### FEATURES

- Real-Time Clock Counts Seconds Through Centuries in BCD Format
  - bq4802Y: 5-V Operation
  - bq4802LY: 3.3-V Operation
- On-Chip Battery-Backup Switchover Circuit With Nonvolatile Control for External SRAM
- Less Than 500 nA of Clock Operation Current in Backup Mode
- Microprocessor Reset With Push-Button Override
- Independent Watchdog Timer With Programmable Time-Out Period
- Power-Fail Interrupt Warning
- Programmable Clock Alarm Interrupt Active in Battery-Backup Mode
- Programmable Periodic Interrupt
- Battery-Low Warning
- 28-pin SOIC, TSSOP, and SNAPHAT Package Options

### APPLICATIONS

- Telecommunications Base Stations
- Servers
- Handheld Data Collection Equipment
- Medical Equipment
- Handheld Instrumentation
- Test Equipment

### DESCRIPTION

The bq4802Y/bq4802LY real-time clock is a low-power microprocessor peripheral that integrates a time-of-day clock, a century-based calendar, and a CPU supervisor, with package options including a 28-pin SOIC, TSSOP, or SNAPHAT that requires the bq48SH-28x6 to complete the two-piece module. The bq4802Y/bq4802LY is ideal for fax machines, copiers, industrial control systems, point-of-sale terminals, data loggers, and computers.

### TYPICAL APPLICATION

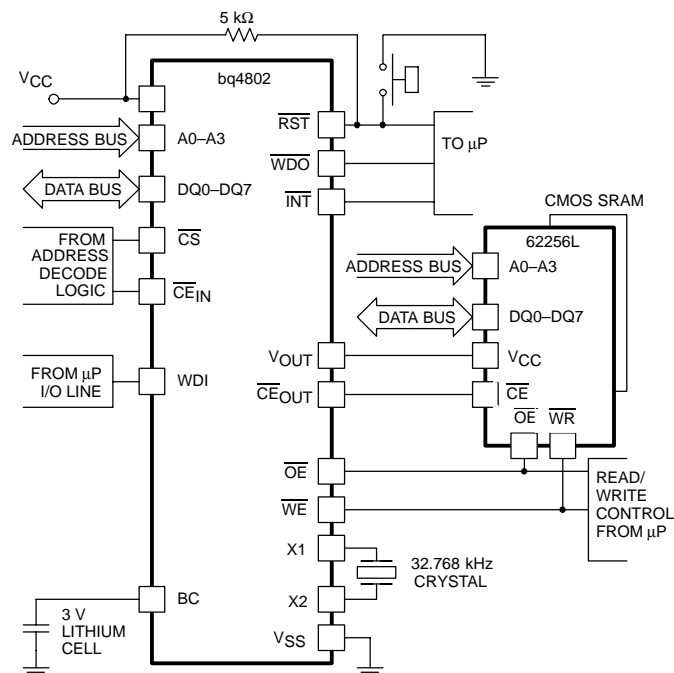

Please be aware that an important notice concerning availability, standard warranty, and use in critical applications of Texas Instruments semiconductor products and disclaimers thereto appears at the end of this data sheet.



These devices have limited built-in ESD protection. The leads should be shorted together or the device placed in conductive foam during storage or handling to prevent electrostatic damage to the MOS gates.

## DESCRIPTION (CONTINUED)

The bq4802Y/bq4802LY provides direct connections for a 32.768-kHz quartz crystal and a 3-V backup battery. Through the use of the conditional chip enable output ( $\overline{CE}_{OUT}$ ) and battery voltage output ( $V_{OUT}$ ) pins, the bq4802Y/bq4802LY can write-protect and make non-volatile external SRAMs. The backup cell powers the real-time clock and maintains SRAM information in the absence of system voltage. The crystal and battery are contained within the modules for a more integrated solution.

The bq4802Y/bq4802LY contains a temperature-compensated reference and comparator circuit that monitors the status of its voltage supply. When the bq4802Y/bq4802LY detects an out-of-tolerance condition, it generates an interrupt warning and subsequently a microprocessor reset. The reset stays active for 200 ms after  $V_{CC}$  rises within tolerance, to allow for power supply and processor stabilization. The reset function also allows for an external push-button override.

## ORDERING INFORMATION

T <sub>A</sub>	OPERATION	DEVICES			SYMBOL
		SOIC(1) (DW)	TSSOP(1) (PW)	SNAPHAT(1)(2)(3) (DSH)	
0°C to +70°C	5 V	bq4802YDW	bq4802YPW	bq4802YDSH	bq4802Y
	3.3 V	bq4802LYDW	bq4802LYPW	bq4802LYDSH	bq4802LY

(1) The DW, PW and DSH packages are available taped and reeled. Add an R suffix to the device type (i.e., bq4802YDWR).

(2) The DSH package is available taped only.

(3) The bq48SH–28x6 should be ordered to complete the SNAPHAT module and is the same part number for both 3.3-V and 5-V modules.

**CAUTION: Wave soldering of DSH package may cause damage to SNAPHAT sockets.**

## ABSOLUTE MAXIMUM RATINGS

over operating free-air temperature range unless otherwise noted<sup>(1)</sup>

	bq4802Y bq4802LY
Input voltage range, $V_{CC}$ , $V_T$ ( $V_T \leq V_{CC} + 0.3$ )	–0.3 V to 6.0 V
Operating temperature range, $T_J$	0°C to 70°C
Storage temperature range, $T_{stg}$	–55°C to 125°C
Temperature under bias, $T_{Jbias}$	–40°C to 85°C
Lead temperature 1,6 mm (1/16 inch) from case for 10 seconds	300°C

(1) Stresses beyond those listed under “absolute maximum ratings” may cause permanent damage to the device. These are stress ratings only, and functional operation of the device at these or any other conditions beyond those indicated under “recommended operating conditions” is not implied. Exposure to absolute-maximum-rated conditions for extended periods may affect device reliability.

## RECOMMENDED OPERATING CONDITIONS

		MIN	MAX	UNIT
Supply voltage, $V_{CC}$	bq4802Y	4.5	5.5	V
	bq4802LY	2.7	3.6	
Input low voltage, $V_{IL}$		–0.3	0.8	V
Input high voltage, $V_{IH}$		2.2	$V_{CC} + 0.3$	V
Backup cell voltage, $V_{BC}$		2.4	4.0	V
Push button reset input low, $V_{BC}$		–0.3	0.4	V
Push button reset input high, $V_{PBRH}$		2.2	$V_{CC} + 0.3$	V

## ELECTRICAL CHARACTERISTICS

( $T_A = 25^\circ\text{C}$ ,  $V_{CC(\text{min})} \leq V_{CC} \leq V_{CC(\text{max})}$  unless otherwise noted)

INPUT SUPPLY						
PARAMETER		TEST CONDITIONS	MIN	TYP	MAX	UNIT
$I_{CC}$	Supply current	100% Minimum duty cycle, $\overline{CS} = V_{IL}$ , $I_{I/O} = 0 \text{ mA}$		5	9	mA
$I_{SB1}$	Standby supply current	$\overline{CS} = V_{IH}$		3		mA
		$\overline{CS} = V_{CC} - 0.2 \text{ V}$ , $0 \text{ V} \leq V_{IN} \leq 0.2 \text{ V}$ or $V_{IN} = V_{CC} - 0.2 \text{ V}$		1.5		
$I_{CCB}$	Battery operation supply current	$V_{BC} = 3 \text{ V}$ , $T_A = 25^\circ\text{C}$ , No load at $V_{OUT}$ or $\overline{CE}_{OUT}$ , $I_{I/O} = 0 \text{ mA}$		0.3	0.5	$\mu\text{A}$
$I_{LI}$	Input leakage current	$V_{IN} = V_{SS}$ to $V_{CC}$	-1		1	$\mu\text{A}$
$I_{LO}$	Output leakage current	$\overline{CS} = V_{IH}$ or $\overline{OE} = V_{IH}$ or $\overline{WE} = V_{IL}$	-1		1	$\mu\text{A}$
$V_{OUT(1)}$	Output voltage	$I_{OUT} = 80 \text{ mA}$ , $V_{CC} > V_{BC}$	$V_{CC} - 0.3$			V
$V_{OUT(2)}$		$I_{OUT} = 100 \mu\text{A}$ , $V_{CC} < V_{BC}$	$V_{BC} - 0.3$			
$V_{PFD}$	Power fail detect voltage	bq4802Y	4.30	4.37	4.5	V
		bq4802LY	2.4	2.53	2.65	
$V_{SO}$	Supply switch over voltage	$V_{BC} > V_{(PFD)}$	$V_{PFD}$			V
		$V_{BC} < V_{(PFD)}$	$V_{BC}$			
$V_{RST}$	RST output voltage <sup>(1)</sup>	$I_{(RST)} = 4 \text{ mA}$			0.4	V
$V_{INT}$	INT output voltage <sup>(1)</sup>	$I_{(INT)} = 4 \text{ mA}$			0.4	V

(1)  $\overline{RST}$  and  $\overline{INT}$  are open drain outputs.

WATCHDOG						
PARAMETER		TEST CONDITIONS	MIN	TYP	MAX	UNIT
$I_{(WDIL)}$	Low-level watchdog input current		-50	-10		$\mu\text{A}$
$I_{(WDIH)}$	High-level watchdog input current			20	50	
$V_{(WDO)}$	$\overline{WDO}$ output voltage	$I_{SINK} = 4 \text{ mA}$			0.4	V
		$I_{SOURCE} = 2 \text{ mA}$	2.4			

CRYSTAL SPECIFICATIONS (DT-26) OR EQUIVALENT						
PARAMETER		TEST CONDITIONS	MIN	TYP	MAX	UNIT
$f_O$	Oscillation frequency			32.768		kHz
$C_L$	Load capacitance			6		pF
$T_P$	Temperature turnover point		20	25	30	$^\circ\text{C}$
$k$	Parabolic curvature constant				-0.042	ppm/ $^\circ\text{C}$
$Q$	Quality factor		40,000	70,000		
$R_1$	Series resistance				45	k $\Omega$
$C_0$	Shunt capacitance			1.1	1.8	pF
$C_0/C_1$	Capacitance ratio			430	600	
$D_L$	Drive level				1	$\mu\text{W}$
$\Delta f/f_0$	Aging (first year at $25^\circ\text{C}$ )			1	-	ppm

CAPACITANCE						
PARAMETER		TEST CONDITIONS	MIN	TYP	MAX	UNIT
$I_{I/O}$	Input/output capacitance	$V_{Out} = 0 \text{ V}$			7	pF
$C_I$	Input capacitance	$V = 0 \text{ V}$			5	

**AC TEST CONDITIONS, INPUT PULSE LEVELS  $V_I = 0\text{ V}$  to  $3.0\text{ V}$ ,  $t_R = t_F = 5\text{ NS}$ ,  $V_{REF} = 1.5\text{ V}$**

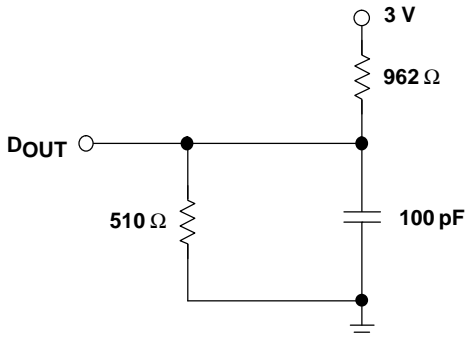

Figure 1. Output Load A

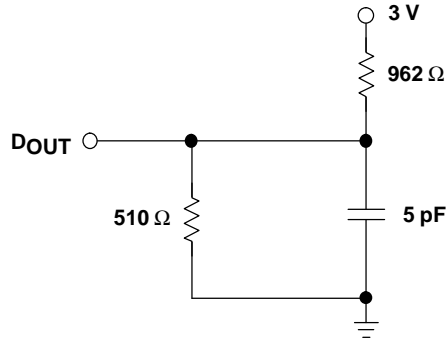

Figure 2. Output Load B

**OPERATING CHARACTERISTICS**

**READ CYCLE ( $T_A = T_{OPR}$ ,  $V_{CC} = 5\text{ V}$ )**

PARAMETER		TEST CONDITIONS	MIN	MAX	UNIT
$t_{RC}$	Read cycle time		200		ns
$t_{AA}$	Address access time	Output load A		100	ns
$t_{ACS}$	Chip select access time	Output load A		100	ns
$t_{OE}$	Output enable to output valid	Output load A		100	ns
$t_{CLZ}$	Chip select to output low Z	Output load B	8		ns
$t_{OLZ}$	Output enable until output low Z	Output load B	0		ns
$t_{CHZ}$	Output enable until output high Z	Output load B	0	45	ns
$t_{OHZ}$	Output disable until output high Z	Output load B	0	45	ns
$t_{OH}$	Output hold from address change	Output load A	10		ns

**READ CYCLE ( $T_A = T_{OPR}$ ,  $V_{CC} = 3.3\text{ V}$ )**

PARAMETER		TEST CONDITIONS	MIN	MAX	UNIT
$t_{RC}$	Read cycle time		300		ns
$t_{AA}$	Address access time	Output load A		150	ns
$t_{ACS}$	Chip select access time	Output load A		150	ns
$t_{OE}$	Output enable to output valid	Output load A		150	ns
$t_{CLZ}$	Chip select to output low Z	Output load B	15		ns
$t_{OHL}$	Output enable until output low Z	Output load B	0		ns
$t_{CLH}$	Output enable until output high Z	Output load B	0	60	ns
$t_{OLZ}$	Output disable until output high Z	Output load B	0	60	ns
$t_{OH}$	Output hold from address change	Output load A	18		ns

## PIN ASSIGNMENTS

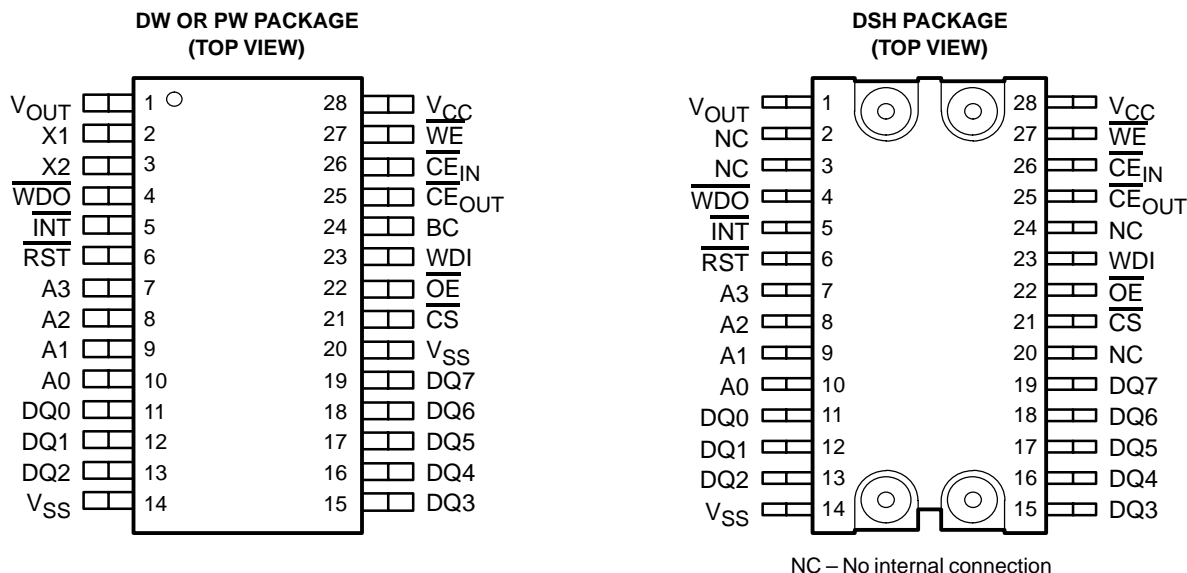

## Terminal Functions

TERMINAL		I/O	DESCRIPTION
NAME	NO.		
A0	10		A0 – A3 allow access to the 16 bytes of real-time clock and control registers.
A1	9		
A2	8		
A3	7		
BC	24(1)		BC should be connected to a 3-V backup cell. A voltage within the V <sub>BC</sub> range on the BC pin should be present upon power up to provide proper oscillator start-up. Not accessible in module packages.
CE <sub>IN</sub>	26		Input to the chip-enable gating circuit
CE <sub>OUT</sub>	25		CE <sub>OUT</sub> goes low only when CE <sub>IN</sub> is low and V <sub>CC</sub> is above the power fail threshold. If CE <sub>IN</sub> is low, and power fail occurs, CE <sub>OUT</sub> stays low for 100 μs or until CE <sub>IN</sub> goes high, whichever occurs first.
CS	21	I	Chip-select input
DQ0	11	I	DQ0–DQ7 provide x8 data for real-time clock information. These pins connect to the memory data bus.
DQ1	12	I	
DQ2	13	I	
DQ3	15	I	
DQ4	16	I	
DQ5	17	I	
DQ6	18	I	
DQ7	19	I	
INT	5		INT goes low when a power fail, periodic, or alarm condition occurs. INT is an open-drain output.
OE	22		OE provides the read control for the RTC memory locations.
RST	6		RST goes low whenever V <sub>CC</sub> falls below the power fail threshold. RST remains low for 200 ms (typical) after V <sub>CC</sub> crosses the threshold on power-up. The bq4802Y/bq4802LY also enters the reset cycle when RST is released from being pulled low for more than 1 μs.
V <sub>CC</sub>	28	I	5-V or 3.3-V input
V <sub>OUT</sub>	1	O	V <sub>OUT</sub> provides the higher of V <sub>CC</sub> or V <sub>BC</sub> , switched internally, to supply external RAM.
V <sub>SS</sub>	14		Ground
	20(1)		

(1) This pin should be left unconnected (NC) when using the SNAPHAT (DSH) package.

Terminal Functions (Continued)

TERMINAL		I/O	DESCRIPTION
NAME	NO.		
WDI	23	I	WDI is a three-level input. If WDI remains either high or low for longer than the watchdog time-out period (1.5-s default), WDO goes low. WDO remains low until the next transition at WDI. Leaving WDI unconnected disables the watchdog function. WDI connects to an internal voltage divider between V <sub>OUT</sub> and V <sub>SS</sub> , which sets it to mid-supply when left unconnected.
$\overline{WDO}$	4		$\overline{WDO}$ goes low if WDI remains either high or low longer than the watchdog time-out period. $\overline{WDO}$ returns high on the next transition at WDI. $\overline{WDO}$ remains high if WDI is unconnected.
$\overline{WE}$	27		$\overline{WE}$ provides the write control for the RTC memory locations.
X1	2(1)		Crystal connection
X2	3(1)		

FUNCTIONAL BLOCK DIAGRAM

Figure 3 is a block diagram of the bq4802Y/bq4802LY. The following sections describe the bq4802Y/bq4802LY functional operation including clock interface, data-retention modes, power-on reset timing, watchdog timer activation, and interrupt generation.

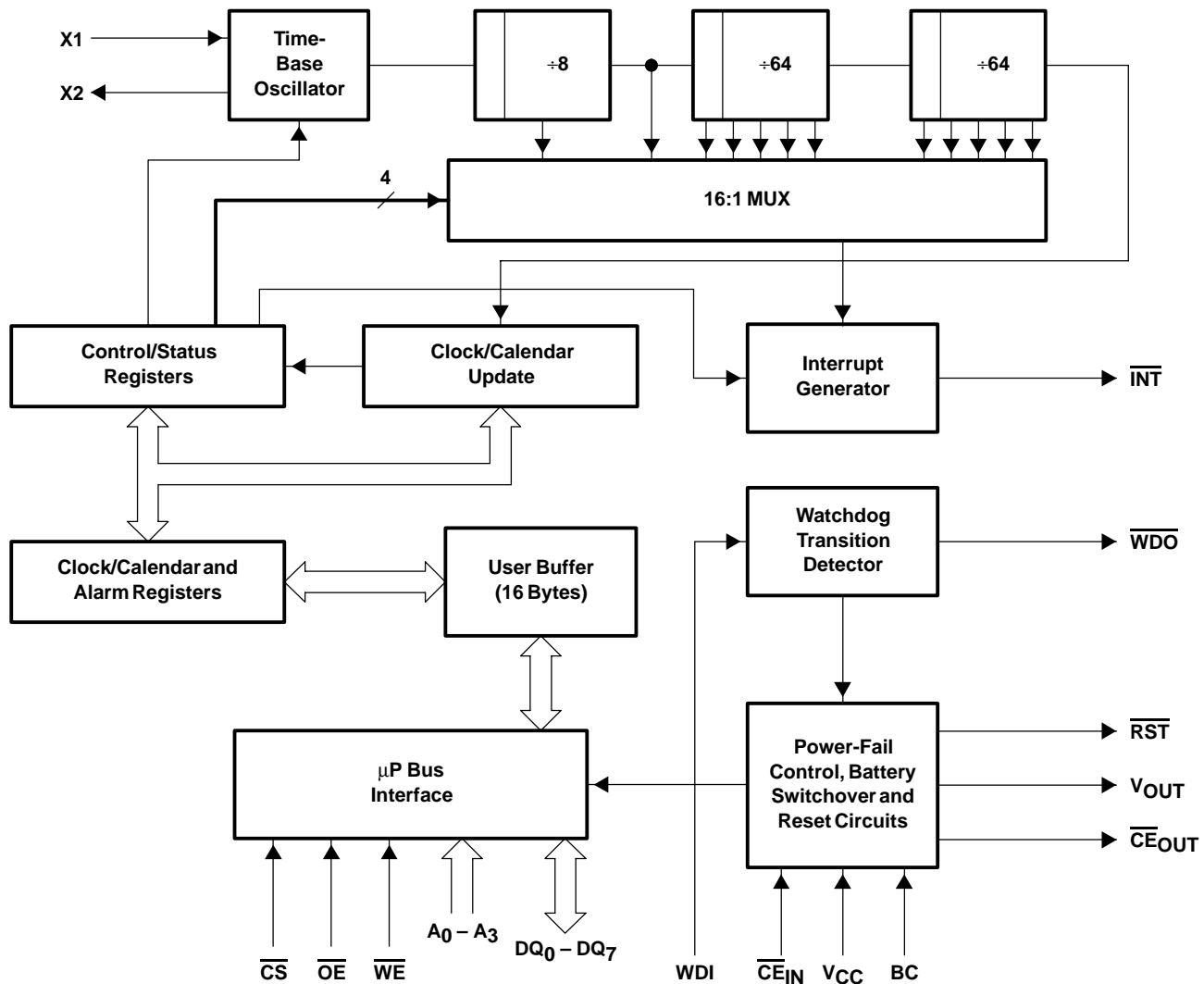
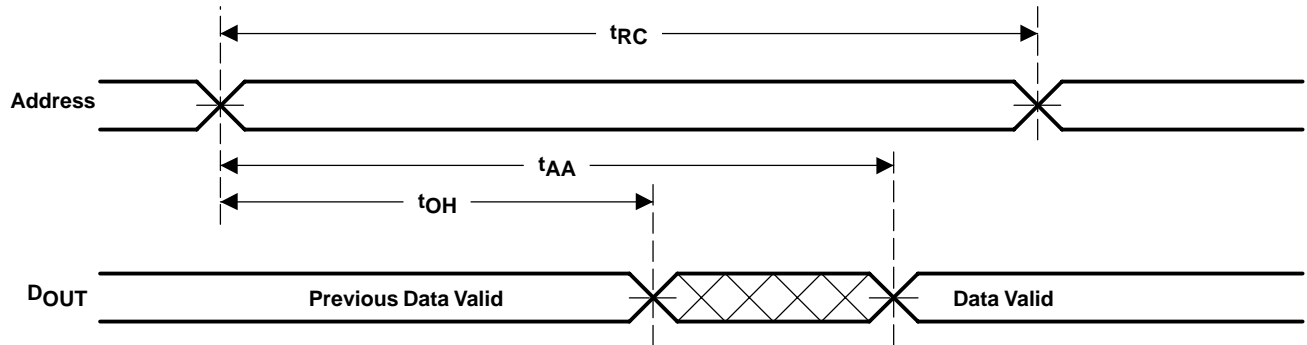

Figure 3. Block Diagram

**READ CYCLE TIMING DIAGRAMS**



- NOTES: A.  $\overline{WE}$  is held high for a read cycle.  
 B. Device is continuously selected:  $\overline{CS} = \overline{OE} = V_{IL}$ .

**Figure 4. Read Cycle No. 1 – Address Access**

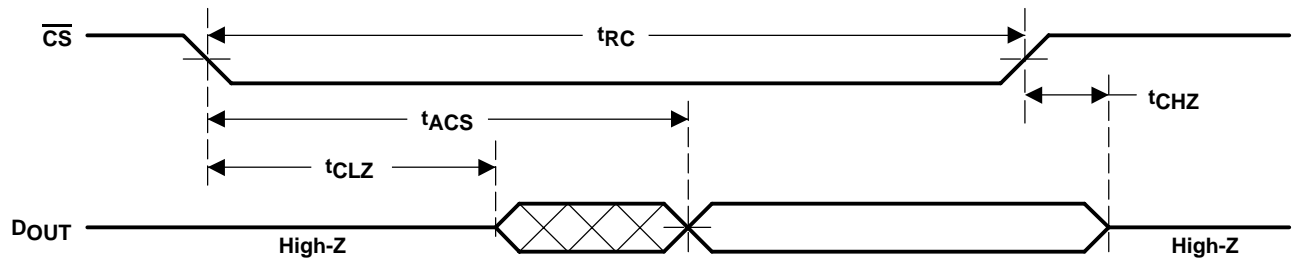

- NOTES: A.  $\overline{WE}$  is held high for a read cycle.  
 B. Device is continuously selected:  $\overline{CS} = \overline{OE} = V_{IL}$ .  
 C.  $OE = V_{IL}$ .

**Figure 5. Read Cycle No. 2 –  $\overline{CS}$  Access**

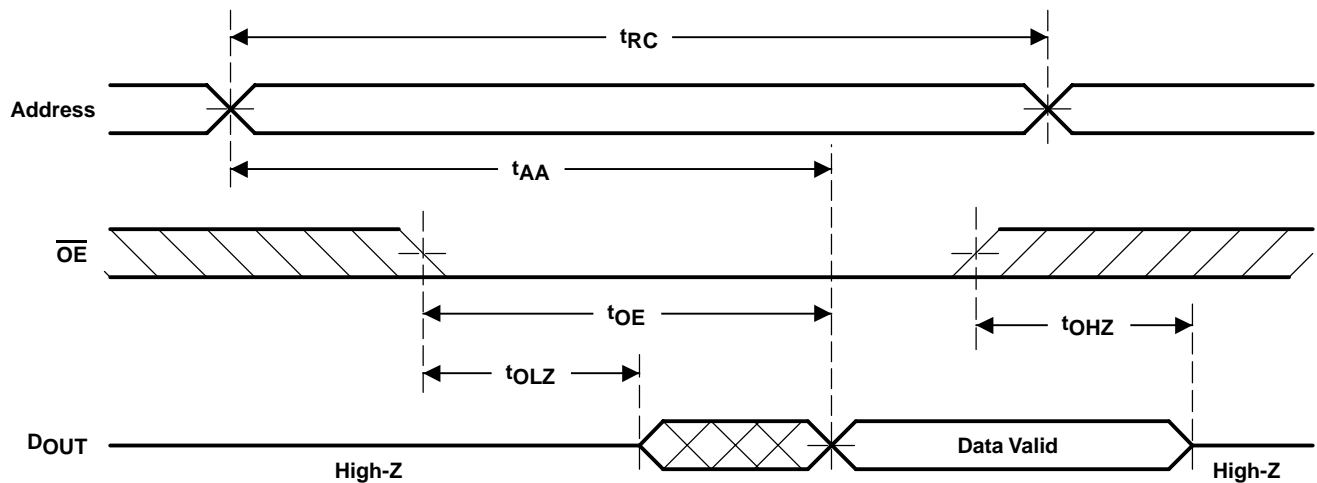

- NOTES: A.  $\overline{WE}$  is held high for a read cycle.  
 B.  $\overline{CS} = V_{IL}$ .

**Figure 6. Read Cycle No. 3 –  $\overline{OE}$  Access**

WRITE CYCLE TIMING DIAGRAMS

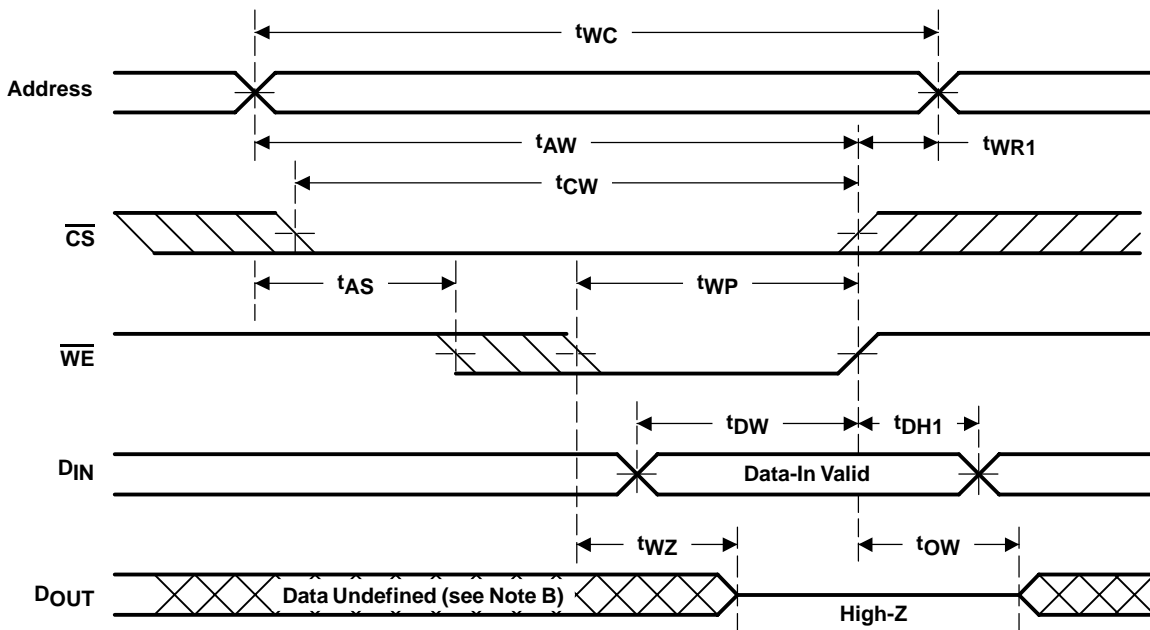

- NOTES: A.  $\overline{WE}$  or  $\overline{CS}$  must be held high during address transition.  
 B. Because I/O may be active ( $\overline{OE}$  low) during the period, data input signals of opposite polarity to the outputs must be applied.  
 C. If  $\overline{OE}$  is high, the I/O pins remain in a state of high impedance.

Figure 7. Write Cycle No. 1 –  $\overline{WE}$  Controlled

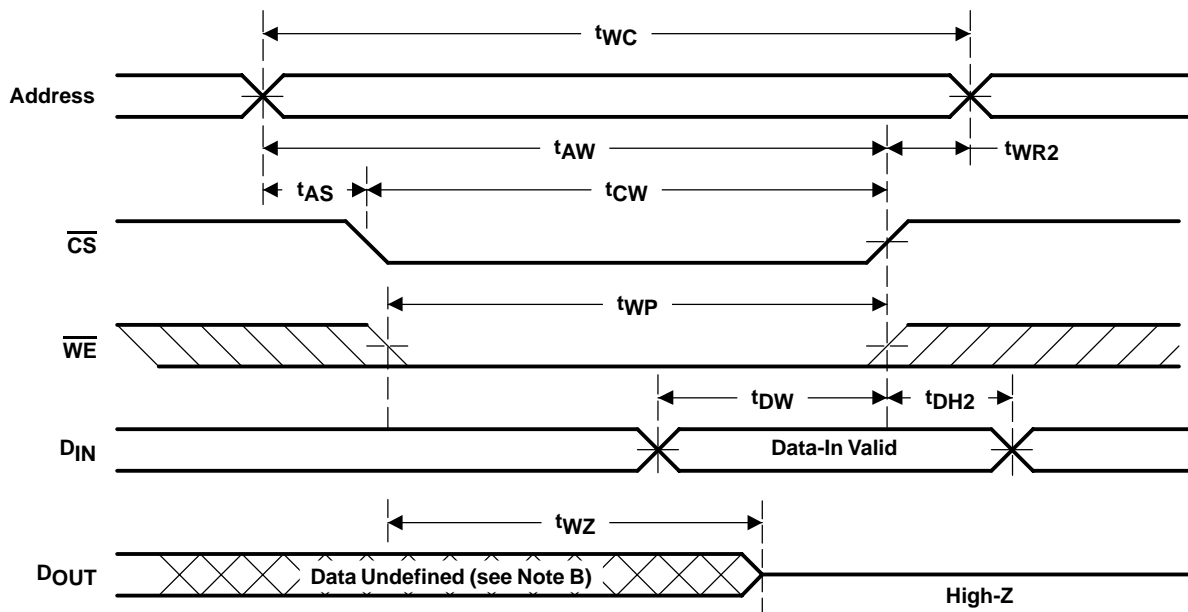

- NOTES: A.  $\overline{WE}$  or  $\overline{CS}$  must be held high during address transition.  
 B. Because I/O may be active ( $\overline{OE}$  low) during the period, data input signals of opposite polarity to the outputs must be applied.  
 C. If  $\overline{OE}$  is high, the I/O pins remain in a state of high impedance.  
 D. Either  $t_{WR1}$  or  $t_{WR2}$  must be met.  
 E. Either  $t_{DH1}$  or  $t_{DH2}$  must be met.

Figure 8. Write Cycle No. 2 –  $\overline{CS}$  Controlled



**WRITE CYCLE ( $T_A = T_{OPR}$ ,  $V_{CC} = 5\text{ V}$ )**

PARAMETER		TEST CONDITIONS	MIN	MAX	UNIT
t <sub>WC</sub>	Write cycle time		200		ns
t <sub>CW</sub>	Chip select to end of write	See Note 1	195		ns
t <sub>AW</sub>	Address valid to end of write	See Note 1	195		ns
t <sub>AS</sub>	Address setup time	Measured from address valid to beginning of write <sup>(2)</sup>	30		ns
t <sub>WP</sub>	Write pulse width	Measured from beginning of write to end of write <sup>(1)</sup>	165		ns
t <sub>WR1</sub>	Write recovery time (write cycle 1)	Measured from $\overline{WE}$ going high to end of write cycle <sup>(3)</sup>	5		ns
t <sub>WR2</sub>	Write recovery time (write cycle 2)	Measured from $\overline{CS}$ going high to end of write cycle <sup>(3)</sup>	15		ns
t <sub>DW</sub>	Data valid to end of write	Measured to first low-to-high transition of either $\overline{CS}$ or $\overline{WE}$	50		ns
t <sub>DH1</sub>	Data hold time (write cycle 1)	Measured from $\overline{WE}$ going high to end of write cycle <sup>(4)</sup>	0		ns
t <sub>DH2</sub>	Data hold time (write cycle 2)	Measured from $\overline{CS}$ going high to end of write cycle <sup>(4)</sup>	10		ns
t <sub>WZ</sub>	Write enable to output high Z	I/O pins are in output state. <sup>(5)</sup>	0	45	ns
t <sub>OW</sub>	Output active from end of write	I/O pins are in output state. <sup>(5)</sup>	0		ns

- (1) A write cycle ends at the earlier transition of  $\overline{CS}$  going high and  $\overline{WE}$  going high.  
(2) A write occurs during the overlap of a low  $\overline{CS}$  and a low  $\overline{WE}$ . A write cycle begins at the later transition of  $\overline{CS}$  going low or  $\overline{WE}$  going low.  
(3) Either t<sub>WR1</sub> or t<sub>WR2</sub> must be met.  
(4) Either t<sub>DH1</sub> or t<sub>DH2</sub> must be met.  
(5) If  $\overline{CS}$  goes low simultaneously with  $\overline{WE}$  going low or after  $\overline{WE}$  going low, the outputs remain in high Z state.

**WRITE CYCLE ( $T_A = T_{OPR}$ ,  $V_{CC} = 3.3\text{ V}$ )**

PARAMETER		TEST CONDITIONS	MIN	MAX	UNIT
t <sub>WC</sub>	Write cycle time		300		ns
t <sub>CW</sub>	Chip select to end of write	See Note 1	250		ns
t <sub>AW</sub>	Address valid to end of write	See Note 1	250		ns
t <sub>AS</sub>	Address setup time	Measured from address valid to beginning of write <sup>(2)</sup>	56		ns
t <sub>WP</sub>	Write pulse width	Measured from beginning of write to end of write <sup>(1)</sup>	280		ns
t <sub>WR1</sub>	Write recovery time (write cycle 1)	Measured from $\overline{WE}$ going high to end of write cycle <sup>(3)</sup>	8		ns
t <sub>WR2</sub>	Write recovery time (write cycle 2)	Measured from $\overline{CS}$ going high to end of write cycle <sup>(3)</sup>	25		ns
t <sub>DW</sub>	Data valid to end of write	Measured to first low-to-high transition of either $\overline{CS}$ or $\overline{WE}$	80		ns
t <sub>DH1</sub>	Data hold time (write cycle 1)	Measured from $\overline{WE}$ going high to end of write cycle <sup>(4)</sup>	0		ns
t <sub>DH2</sub>	Data hold time (write cycle 2)	Measured from $\overline{CS}$ going high to end of write cycle <sup>(4)</sup>	15		ns
t <sub>WZ</sub>	Write enable to output high Z	I/O pins are in output state. <sup>(5)</sup>	0	60	ns
t <sub>OW</sub>	Output active from end of write	I/O pins are in output state. <sup>(5)</sup>	0		ns

- (1) A write cycle ends at the earlier transition of  $\overline{CS}$  going high and  $\overline{WE}$  going high.  
(2) A write occurs during the overlap of a low  $\overline{CS}$  and a low  $\overline{WE}$ . A write cycle begins at the later transition of  $\overline{CS}$  going low or  $\overline{WE}$  going low.  
(3) Either t<sub>WR1</sub> or t<sub>WR2</sub> must be met.  
(4) Either t<sub>DH1</sub> or t<sub>DH2</sub> must be met.  
(5) If  $\overline{CS}$  goes low simultaneously with  $\overline{WE}$  going low or after  $\overline{WE}$  going low, the outputs remain in high Z state.

**POWER-DOWN/POWER-UP TIMING ( $T_A = T_{OPR}$ )**

PARAMETER		TEST CONDITIONS	MIN	TYP	MAX	UNIT
$t_F$	$V_{CC}$ slew rate fall time	3.0 V to 0 V	300			$\mu s$
$t_R$	$V_{CC}$ slew rate rise time	$V_{SO}$ to $V_{PDF(max)}$	100			
$t_{PF}$	Interrupt delay time from $V_{PDF}$	bq4802Y	6		24	
		bq4802LY	10		40	
$t_{WPT}$	Write-protect time for external SRAM	bq4802Y	See Note 1	90	100	125
		bq4802LY	See Note 1	150	170	210
$t_{CSR}$	$\overline{CS}$ at $V_{HI}$ after power-up	bq4802Y	See Note 2	100	200	300
		bq4802LY	See Note 2	170	330	500
$t_{RST}$	$V_{PDF}$ to $\overline{RST}$ active (reset active time-out period)		$t_{CSR}$		$t_{CSR}$	$ms$
$t_{CER}$	Device enable recovery time	See Note 3	$t_{CSR}$		$t_{CSR}$	
$t_{CED}$	Device enable propagation delay time to external SRAM	bq4802Y		9	15	$ns$
		bq4802LY	Output load A		15	
$t_{PBL}$	Push-button low time		1			$\mu s$

- (1) Delay after  $V_{CC}$  slews down past  $V_{PDF}$  before SRAM is write protected and  $\overline{RST}$  activated.
- (2) Internal write-protection period after  $V_{CC}$  passes  $V_{PDF}$  on power up.
- (3) Time during which external SRAM is write protected after  $V_{CC}$  passes  $V_{PDF}$  on power up.

**CAUTION: NEGATIVE UNDERSHOOTS BELOW THE ABSOLUTE MAXIMUM RATING OF  $-0.3$  V IN BATTERY-BACKUP MODE MAY AFFECT DATA INTEGRITY.**

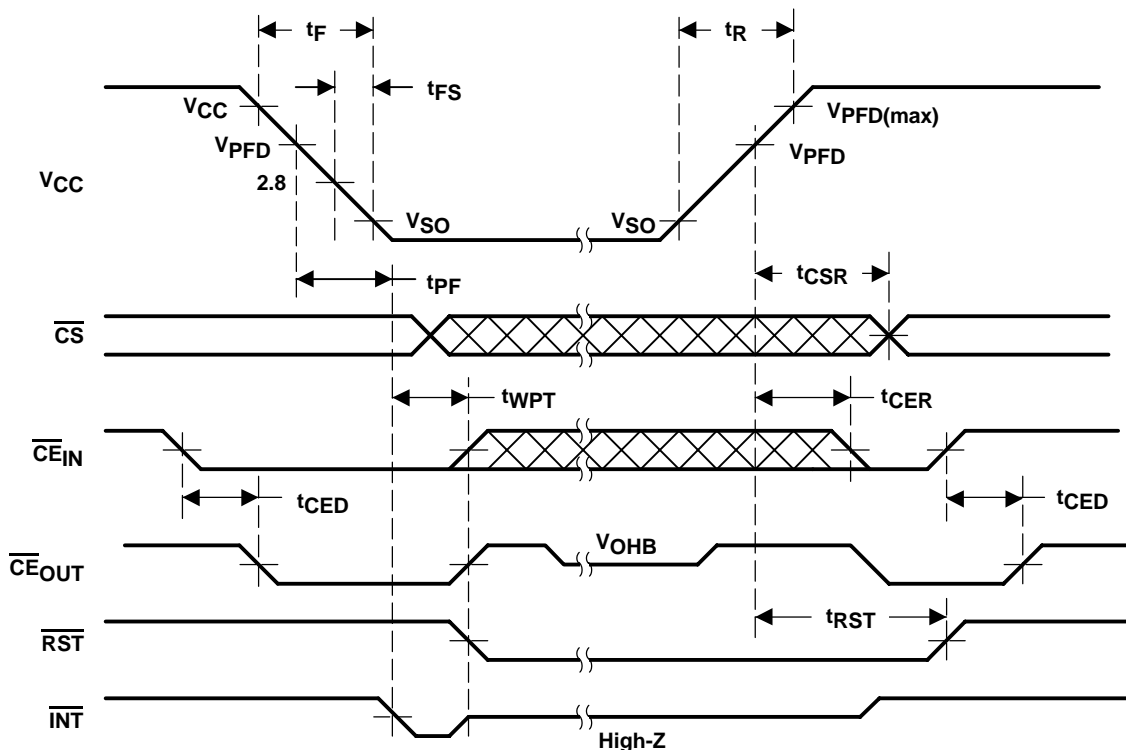

- NOTES: A.  $\overline{PWRIE}$  set to 1 to enable power fail interrupt.
- B.  $\overline{RST}$  and  $\overline{INT}$  are open drain and require an external pullup resistor.

**Figure 9. Power-Down/Power-Up Timing Diagram**

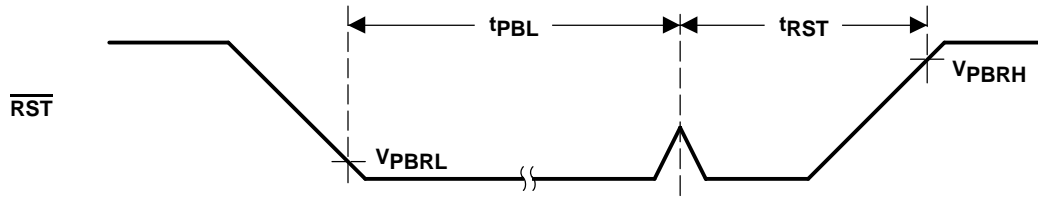

Figure 10. Push-Button Reset Timing

## FUNCTIONAL DESCRIPTION

The following sections describe the bq4802Y/bq4802LY functional operation including clock interface, data-retention modes, power-on reset timing, watchdog timer activation, and interrupt generation.

**Table 1. Operational Truth Table**

V <sub>CC</sub>	$\overline{\text{CS}}$	$\overline{\text{OE}}$	$\overline{\text{WE}}$	$\overline{\text{CE}}_{\text{OUT}}$	V <sub>OUT</sub>	MODE	DQ	POWER
< V <sub>CC</sub> (MAX)	V <sub>IH</sub>	X	X	$\overline{\text{CE}}_{\text{IN}}$	V <sub>OUT1</sub>	Deselect	High Z	Standby
	V <sub>IL</sub>	X	V <sub>IL</sub>	$\overline{\text{CE}}_{\text{IN}}$	V <sub>OUT1</sub>	Write	D <sub>IN</sub>	Active
> V <sub>CC</sub> (MIN)	V <sub>IL</sub>	V <sub>IL</sub>	V <sub>IH</sub>	$\overline{\text{CE}}_{\text{IN}}$	V <sub>OUT1</sub>	Read	D <sub>OUT</sub>	Active
	V <sub>IL</sub>	V <sub>IH</sub>	V <sub>IH</sub>	$\overline{\text{CE}}_{\text{IN}}$	V <sub>OUT1</sub>	Read	High-Z	Active
<V <sub>PPFD</sub> (MIN)>V <sub>SO</sub>	X	X	X	V <sub>OH</sub>	V <sub>OUT1</sub>	Deselect	High-Z	CMOS standby
≤ V <sub>SO</sub>	X	X	X	V <sub>OH</sub> B	V <sub>OUT2</sub>	Deselect	High-Z	Battery-backup mode

## ADDRESS MAP

The bq4802Y/bq4802LY provides 16 bytes of clock and control status registers. Table 1 is a map of the bq4802Y/bq4802LY registers, and Table 2 describes the register bits.

**Table 2. Clock and Control Register Map**

Addr (h)	D7	D6	D5	D4	D3	D2	D1	D0	Range (h)	Register	
0	0	10-second digit			1-second digit				00–59	Seconds	
1	ALM1	ALM0				1-second digit				00–59	Seconds alarm
		10-second digit									
2	0	10-minutedigit			1-minute digit				00–59	Minutes	
3	ALM1	ALM0				1-minute digit				00–59	Minutes alarm
		10-minutedigit									
4	PM/AM	0	10-hour digit			1-hour digit				01–12AM 81–92PM	Hours
5	ALM1	ALM0	10-hour digit			1-hour digit				01–12AM 81–92PM	Hours alarm
	PM/AM										
6	0	0	10-day digit			1-day digit				01–31	Day
7	ALM1	ALM0	10-day digit			1-day digit				01–31	Day alarm
8	0	0	0	0	0	day of week digit			01–07	Day of Week	
9	0	0	0	10 mo.	1-month digit				01–12	Month	
A	10-year digit				1-year digit				00–99	Year	
B	(1)	WD2	WD1	WD0	RS3	RS2	RS1	RS0	–	Rates	
C	(1)	(1)	(1)	(1)	AIE	PIE	PWRIE	ABE	–	Enables	
D	(1)	(1)	(1)	(1)	AF	PF	PWRF	BVF	–	Flags	
E	(1)	(1)	(1)	(1)	UTI	STOP	24/12	DSE	–	Control	
F	10-century digit				1-century digit				00–99	Century	

- (1) Unused bits; cannot be written to and read as 0.
- (2) Internal write-protection period after V<sub>CC</sub> passes V<sub>PPFD</sub> on power up.
- (3) Clock calendar data in BCD. Automatic leap year adjustment up to year 2100.
- (4) PM/AM = 1 for PM and 0 for AM.
- (5) DSE = 1 to enable daylight savings adjustment.
- (6) 24/12 = 1 to enable 24-hour data representation and 0 for 12-hour data representation.
- (7) Day of week coded as Sunday = 1 through Saturday = 7
- (8) BVF = 1 for valid BC input
- (9) STOP = 1 to turn the RTC on and 0 stops the RTC in battery-backup mode

**Table 3. Clock and Control Register Map**

BIT	DESCRIPTION
24/12	24- or 12-hour data representation
ABE	Alarm interrupt enable in battery-backup mode
AF	Alarm interrupt flag
AIE	Alarm interrupt enable
ALM0–ALM1	Alarm mask bits
BVF	Battery-valid flag
DSE	Daylight savings enable
PF	Periodic interrupt flag
PIE	Periodic interrupt enable
PM/AM	PM or AM indication
PWRF	Power-fail interrupt flag
PWRIE	Power-fail interrupt enable
RS0–RS3	Periodic interrupt rate
STOP	Oscillator stop and start
UTI	Update transfer inhibit
WD0–WD2	Watchdog time-out rate

## CLOCK MEMORY INTERFACE

The bq4802Y/bq4802LY has the same interface for clock/calendar and control information as standard SRAM. To read and write to these locations, the user must put the bq4802Y/bq4802LY in the proper mode and meet the timing requirements.

### READ MODE

The bq4802Y/bq4802LY is in read mode whenever  $\overline{OE}$  (output enable) is low and  $\overline{CS}$  (chip select) is low. The unique address, specified by the four address inputs, defines which one of the 16 clock/calendar bytes is to be accessed. The bq4802Y/bq4802LY makes valid data available at the data I/O pins within  $t_{AA}$  (address access time). This occurs after the last address input signal is stable, and providing the  $\overline{CS}$  and  $\overline{OE}$  (output enable) access times are met. If the  $\overline{CS}$  and  $\overline{OE}$  access times are not met, valid data is available after the latter of chip select access time ( $t_{ACS}$ ) or output enable access time ( $t_{OE}$ ).

$\overline{CS}$  and  $\overline{OE}$  control the state of the eight three-state data I/O signals. If the outputs are activated before  $t_{AA}$ , the data lines are driven to an indeterminate state until  $t_{AA}$ . If the address inputs are changed while  $\overline{CS}$  and  $\overline{OE}$  remain low, output data remains valid for  $t_{OH}$  (output data hold time), but goes indeterminate until the next address access.

### WRITE MODE

The bq4802Y/bq4802LY is in write mode whenever  $\overline{WE}$  and  $\overline{CS}$  are active. The start of a write is referenced from the latter-occurring falling edge of  $\overline{WE}$  or  $\overline{CS}$ . A write is terminated by the earlier rising edge of  $\overline{WE}$  or  $\overline{CS}$ . The addresses must be held valid throughout the cycle.  $\overline{CS}$  or

$\overline{WE}$  must return high for a minimum of  $t_{WR2}$  from  $\overline{CS}$  or  $t_{WR1}$  from  $\overline{WE}$  prior to the initiation of another read or write cycle.

Data-in must be valid  $t_{DW}$  prior to the end of write and remain valid for  $t_{DH1}$  or  $t_{DH2}$  afterward.  $\overline{OE}$  should be kept high during write cycles to avoid bus contention; although, if the output bus has been activated by a low on  $\overline{CS}$  and  $\overline{OE}$ , a low on  $\overline{WE}$  disables the outputs  $t_{WZ}$  after  $\overline{WE}$  falls.

## READING THE CLOCK

Once every second, the user-accessible clock/calendar locations are updated simultaneously from the internal real-time counters. To prevent reading data in transition, updates to the bq4802Y/bq4802LY clock registers should be halted. Updating is halted by setting the update transfer inhibit (UTI) bit D3 of the control register E. As long as the UTI bit is 1, updates to user-accessible clock locations are inhibited. Once the frozen clock information is retrieved by reading the appropriate clock memory locations, the UTI bit should be reset to 0 in order to allow updates to occur from the internal counters. Because the internal counters are not halted by setting the UTI bit, reading the clock locations has no effect on clock accuracy. Once the UTI bit is reset to 0, the internal registers update within one second the user-accessible registers with the correct time. A halt command issued during a clock update allows the update to occur before freezing the data.

## SETTING THE CLOCK

The UTI bit must also be used to set the bq4802Y/bq4802LY clock. Once set, the locations can be written with the desired information in BCD format. Resetting the UTI bit to 0 causes the written values to be transferred to the internal clock counters and allows updates to the user-accessible registers to resume within one second.

## STOPPING AND STARTING THE CLOCK OSCILLATOR

The bq4802Y/bq4802LY clock can be programmed to turn off when the part goes into battery back-up mode by setting  $\overline{STOP}$  to 0 prior to power down. If the board using the bq4802Y/bq4802LY is to spend a significant period of time in storage, the  $\overline{STOP}$  bit can be used to preserve some battery capacity.  $\overline{STOP}$  set to 1 keeps the clock running when  $V_{CC}$  drops below  $V_{SO}$ . With  $V_{CC}$  greater than  $V_{SO}$ , the bq4802Y/bq4802LY clock runs regardless of the state of  $\overline{STOP}$ .

## POWER-DOWN/POWER-UP CYCLE

The bq4802Y/bq4802LY continuously monitors  $V_{CC}$  for out-of-tolerance. During a power failure, when  $V_{CC}$  falls below  $V_{PFD}$ , the bq4802Y/bq4802LY write-protects the clock and storage registers. The power source is switched to BC when  $V_{CC}$  is less than  $V_{PFD}$  and BC is greater than  $V_{PFD}$ , or when  $V_{CC}$  is less than  $V_{BC}$  and  $V_{BC}$  is less than

$V_{PFD}$ . RTC operation and storage data are sustained by a valid backup energy source. When  $V_{CC}$  is above  $V_{PFD}$ , the power source is  $V_{CC}$ . Write-protection continues for  $t_{CSR}$  time after  $V_{CC}$  rises above  $V_{PFD}$ .

An external CMOS static RAM is battery-backed using the  $V_{OUT}$  and chip enable output pins from the bq4802Y/bq4802LY. As the voltage input  $V_{CC}$  slews down during a power failure, the chip enable output,  $\overline{CE}_{OUT}$ , is forced inactive independent of the chip enable input  $\overline{CE}_{IN}$ .

This activity unconditionally write-protects the external SRAM as  $V_{CC}$  falls below  $V_{PFD}$ . If a memory access is in progress to the external SRAM during power-fail detection, that memory cycle continues to completion before the memory is write-protected. If the memory cycle is not terminated within time  $t_{WPT}$ , the chip enable output is unconditionally driven high, write-protecting the controlled SRAM.

As the supply continues to fall past  $V_{PFD}$ , an internal switching device forces  $V_{OUT}$  to the external backup energy source.  $\overline{CE}_{OUT}$  is held high by the  $V_{OUT}$  energy source.

During power up,  $V_{OUT}$  is switched back to the main supply as  $V_{CC}$  rises above the backup cell input voltage sourcing  $V_{OUT}$ . If  $V_{PFD} < V_{BC}$  on the bq4802Y/bq4802LY the switch to the main supply occurs at  $V_{PFD}$ .  $\overline{CE}_{OUT}$  is held inactive for time  $t_{CER}$  (200-ms maximum) after the power supply has reached  $V_{PFD}$ , independent of the  $\overline{CE}_{IN}$  input, to allow for processor stabilization.

During power-valid operation, the  $\overline{CE}_{IN}$  input is passed through to the  $\overline{CE}_{OUT}$  output with a propagation delay of less than 12 ns. Figure 2 shows the hardware hookup for the external RAM, battery, and crystal.

A primary backup energy source input is provided on the bq4802Y/bq4802LY. The BC input accepts a 3-V primary battery, typically some type of lithium chemistry. Since the bq4802Y/bq4802LY provides for reverse battery charging protection, no diode or current limiting resistor is needed in series with the cell. To prevent battery drain when there is no valid data to retain,  $V_{OUT}$  and  $\overline{CE}_{OUT}$  are internally isolated from BC by the initial connection of a battery. Following the first application of  $V_{CC}$  above  $V_{PFD}$ , this isolation is broken, and the backup cell provides power to  $V_{OUT}$  and  $\overline{CE}_{OUT}$  for the external SRAM. The crystal should be located as close to X1 and X2 as possible and meet the specifications in the *crystal specifications* section of the electrical characteristics tables. With the specified crystal, the bq4802Y/bq4802LY RTC is accurate to within one minute per month at room temperature. In the absence of a crystal, a 32.768-kHz waveform can be fed into X1 with X2 grounded. The power source and crystal are integrated into the SNAPHAT modules.

## Power-On Reset

The bq4802Y/bq4802LY provides a power-on reset, which pulls the RST pin low on power down and remains low on power up for  $t_{RST}$  after  $V_{CC}$  passes  $V_{PFD}$ . With valid battery voltage on BC, RST remains valid for  $V_{CC} = V_{SS}$ .

## Push-Button Reset

The bq4802Y/bq4802LY also provides a push-button override to the reset when the device is not already in a reset cycle. When the RST pin is released after being pulled low for 1  $\mu$ s then the RST stays low for 200 ms (typical).

## WATCHDOG TIMER

The watchdog monitors microprocessor activity through the watchdog input (WDI). To use the watchdog function, connect WDI to a bus line or a microprocessor I/O line. If WDI remains high or low for longer than the watchdog time-out period (1.5 seconds default), the bq4802Y/bq4802LY asserts WDO and RST.

### Watchdog Input

The bq4802Y/bq4802LY resets the watchdog timer if a change of state (high-to-low, low-to-high, or a minimum 100 ns pulse) occurs at the watchdog input (WDI) during the watchdog period. The watchdog time-out is set by WD0 – WD2 in register B. The bq4802Y/bq4802LY maintains the watchdog time-out programming through power cycles. The default state (no valid battery power) of WD0 – WD2 is 000 or 1.5 s on power up. Table 3 shows the programmable watchdog time-out rates. The watchdog time-out period immediately after a reset is equal to the programmed watchdog time-out.

To disable the watchdog function, leave WDI floating. An internal resistor network (100-k $\Omega$  equivalent impedance at WDI) biases WDI to approximately 1.6 V. Internal comparators detect this level and disable the watchdog timer. When  $V_{CC}$  is below the power-fail threshold, the bq4802Y/bq4802LY disables the watchdog function and disconnects WDI from its internal resistor network, thus making it high impedance.

### Watchdog Output

The watchdog output ( $\overline{WDO}$ ) remains high if there is a transition or pulse at WDI during the watchdog timeout period. The bq4802Y/bq4802LY disables the watchdog function and  $\overline{WDO}$  is a logic high when  $V_{CC}$  is below the power fail threshold, battery-backup mode is enabled, or WDI is an open circuit. In watchdog mode, if no transition occurs at WDI during the watchdog time-out period, the bq4802Y/bq4802LY asserts  $\overline{RST}$  for the reset time-out period  $t_1$ . WDO goes low and remains low until the next transition at WDI. If WDI is held high or low indefinitely,  $\overline{RST}$  generates pulses ( $t_1$  seconds wide) every  $t_3$  seconds. Figure 11 shows the watchdog timing.

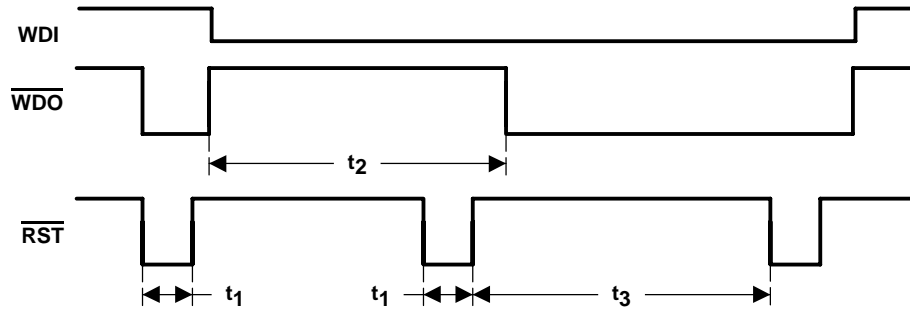

Figure 11. Watchdog Time-Out Period and Reset Active Time

Table 4. Watchdog and Reset Timeout Rates

WD2	WD1	WD0	WATCHDOG TIMEOUT PERIOD	RESET TIMEOUT PERIOD
0	0	0	1.50 s	0.25 ms
0	0	1	23.4375 ms	3.9063 ms
0	1	0	46.875 ms	7.8125 ms
0	1	1	93.750 ms	15.625 ms
1	0	0	187.5 ms	31.25 ms
1	0	1	375 ms	62.5 ms
1	1	0	750 ms	125 ms
1	1	1	3.0 s	0.5 s

## INTERRUPTS

The bq4802Y/bq4802LY allows three individually selected interrupt events to generate an interrupt request on the  $\overline{\text{INT}}$  pin. These three interrupt events are:

- The periodic interrupt, programmable to occur once every 30.5  $\mu\text{s}$  to 500 ms.
- The alarm interrupt, programmable to occur once per second to once per month.
- The power-fail interrupt, which can be enabled to be asserted when the bq4802Y/bq4802LY detects a power failure.

An individual interrupt-enable bit in register C, the interrupts register, enables the periodic, alarm and power-fail interrupts. When an event occurs, its event flag bit in the flags register, register D, is set. If the corresponding event enable bit is also set, then an interrupt request is generated. Reading the flags register clears all flag bits and makes  $\overline{\text{INT}}$  high impedance. To reset the flag register, the bq4802Y/bq4802LY addresses must be held stable at register D for at least 50 ns to avoid inadvertent resets.

### Periodic Interrupt

Bits RS3 – RS0 in the interrupt register program the rate for the periodic interrupt. The user can interpret the interrupt in two ways, either by polling the flags register for PF assertion or by setting PIE so that  $\overline{\text{INT}}$  goes active when the bq4802Y/bq4802LY sets the periodic flag. Reading the flags register resets the PF bit and returns  $\overline{\text{INT}}$  to the high-impedance state. Table 5 shows the periodic rates.

Table 5. Periodic Interrupt Rates

REGISTER BITS				PERIODIC INTERRUPT PERIOD
RS3	RS2	RS1	RS0	
0	0	0	0	NONE
0	0	0	1	30.5175 $\mu\text{s}$
0	0	1	0	61.035 $\mu\text{s}$
0	0	1	1	122.070 $\mu\text{s}$
0	1	0	0	244.141 $\mu\text{s}$
0	1	0	1	488.281 $\mu\text{s}$
0	1	1	0	976.5625 $\mu\text{s}$
0	1	1	1	1.95315 ms
1	0	0	0	3.90625 ms
1	0	0	1	7.8125 ms
1	0	1	0	15.625 ms
1	0	1	1	31.25 ms
1	1	0	0	62.5 ms
1	1	0	1	125 ms
1	1	1	0	250 ms
1	1	1	1	500 ms

## ALARM INTERRUPT

Registers 1, 3, 5, and 7 program the real-time clock alarm. During each update cycle, the bq4802Y/bq4802LY compares the date, hours, minutes, and seconds in the clock registers with the corresponding alarm registers. If a match between all the corresponding bytes is found, the alarm flag AF in the flags register is set. If the alarm interrupt is enabled with AIE, an interrupt request is generated on  $\overline{\text{INT}}$ . The alarm condition is cleared by a read to the flags register. ALM1 – ALM0 in the alarm registers, mask each alarm compare byte. Setting ALM1 (D7) and ALM0 (D6) to 1 masks an alarm byte. Alarm byte masking can be used to select the frequency of the alarm interrupt, according to Table 6. The alarm interrupt can be made active while the bq4802Y/bq4802LY is in the battery-backup mode by setting ABE in the interrupts register. Normally, the  $\overline{\text{INT}}$  pin goes high-impedance during battery backup. With ABE set,  $\overline{\text{INT}}$  is driven low if an alarm condition occurs and the AIE bit is set.

**Table 6. Alarm Frequency**

1h	3h	5h	7h	ALARM FREQUENCY
ALM1–ALM0	ALM1–ALM0	ALM1–ALM0	ALM1–ALM0	
1	1	1	1	Once per second
0	1	1	1	Once per minute when seconds match
0	0	1	1	Once per hour, when minutes and seconds match
0	0	0	1	Once per day, when hours, minutes and seconds match
0	0	0	0	When date, hours minutes and seconds match

**POWER–FAIL INTERRUPT**

When  $V_{CC}$  falls to the power-fail-detect point, the power-fail flag PWRF is set. If the power-fail interrupt enable bit (PWRIE) is also set, then  $\overline{INT}$  is asserted low. The power-fail interrupt occurs  $t_{WPT}$  before the bq4802Y/bq4802LY generates a reset and deselected.

**BATTERY–LOW WARNING**

The bq4802Y/bq4802LY checks the battery on power-up. When the battery voltage is approximately 2.1 V, the battery valid flag BVF in the flags register is set to a 0 indicating that clock and RAM data may be invalid.



MECHANICAL DATA

DW (R-PDSO-G\*\*)

PLASTIC SMALL-OUTLINE PACKAGE

16 PINS SHOWN

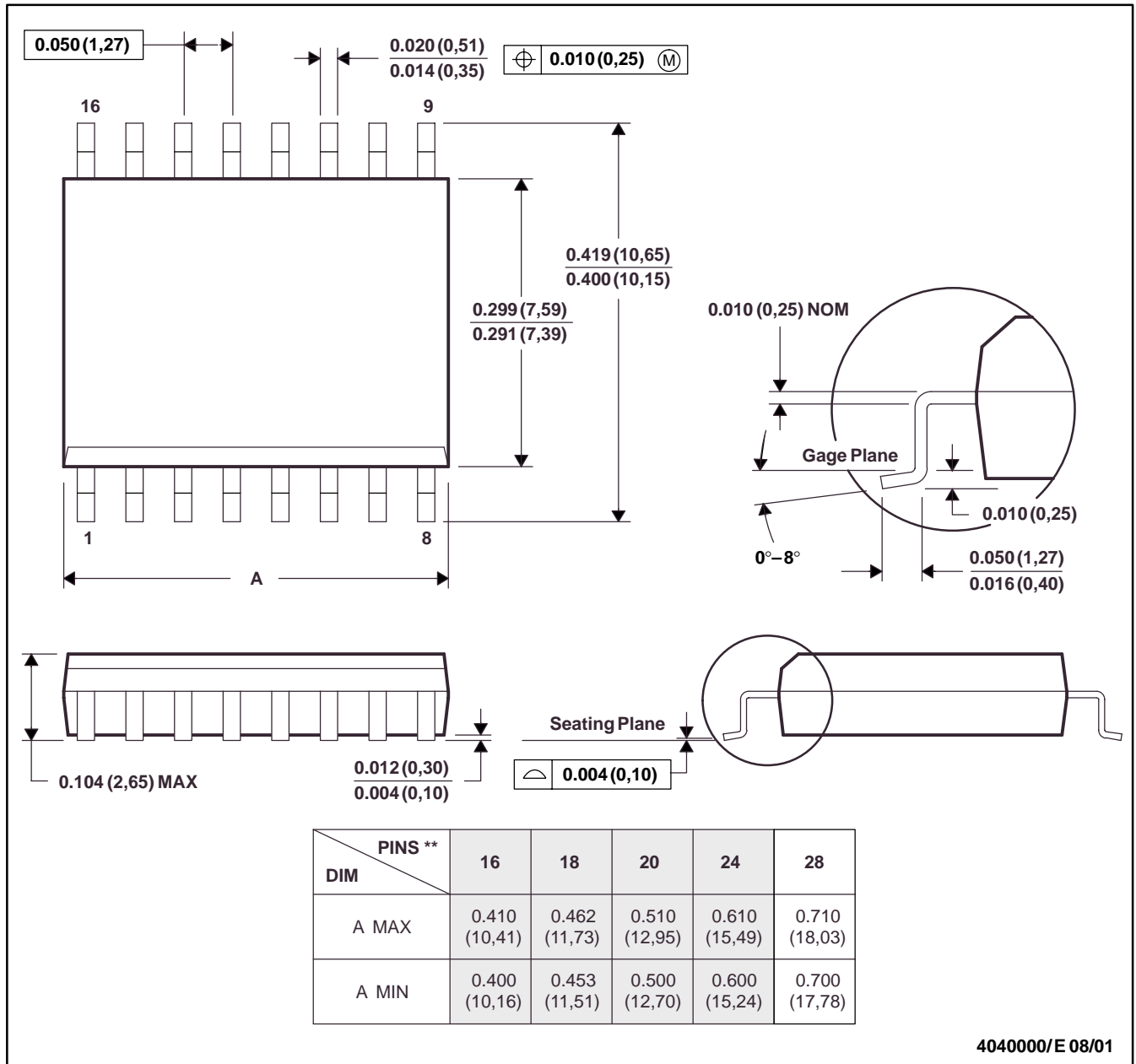

- NOTES: A. All linear dimensions are in inches (millimeters).  
 B. This drawing is subject to change without notice.  
 C. Body dimensions do not include mold flash or protrusion not to exceed 0.006 (0,15).  
 D. Falls within JEDEC MS-013

PW (R-PDSO-G\*\*)

PLASTIC SMALL-OUTLINE PACKAGE

14 PINS SHOWN

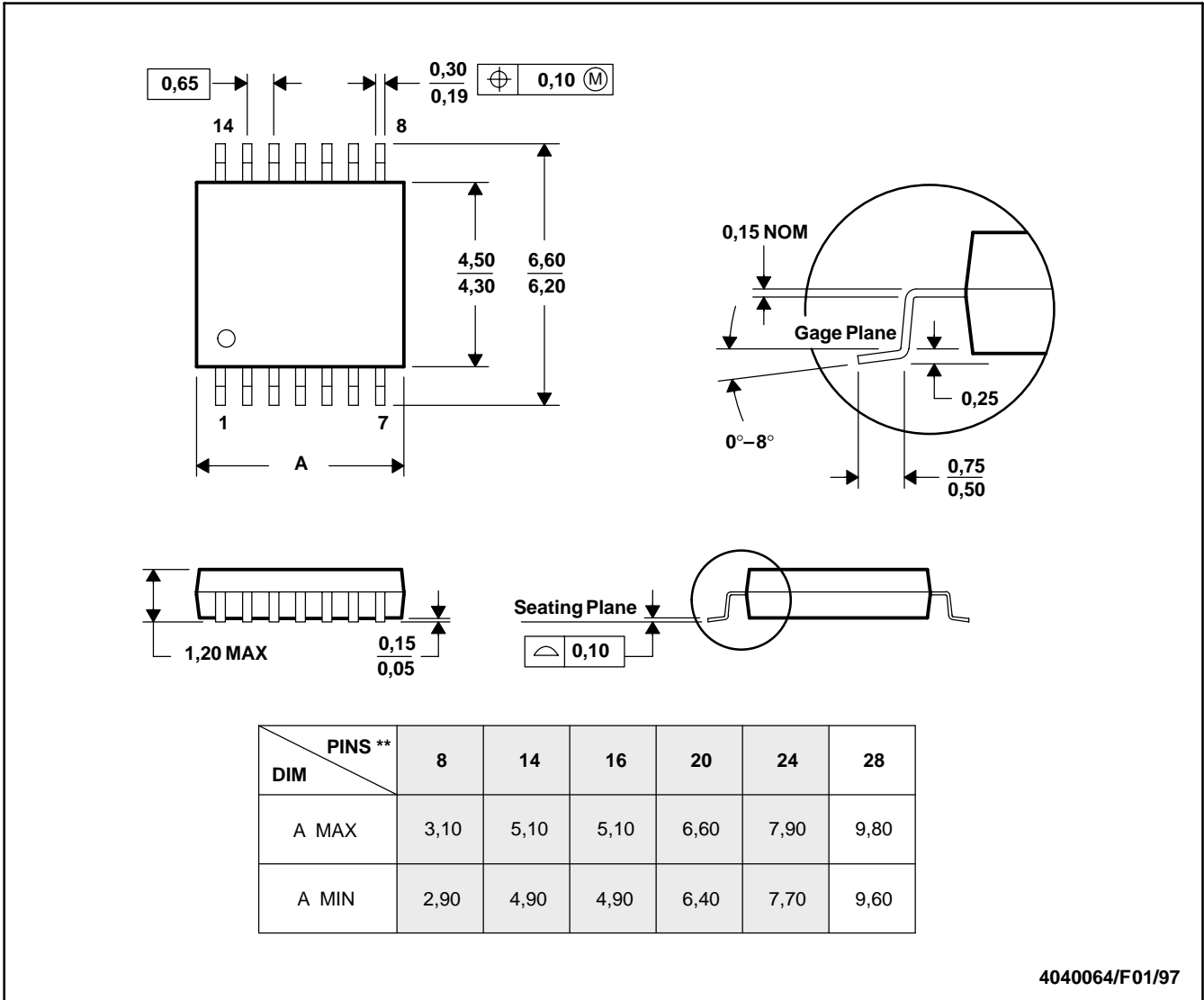

4040064/F01/97

- NOTES: A. All linear dimensions are in millimeters.  
 B. This drawing is subject to change without notice.  
 C. Body dimensions do not include mold flash or protrusion not to exceed 0,15.  
 D. Falls within JEDEC MO-153

MECHANICAL DATA

DSH (R-PDSO-G28)

PLASTIC SMALL-OUTLINE

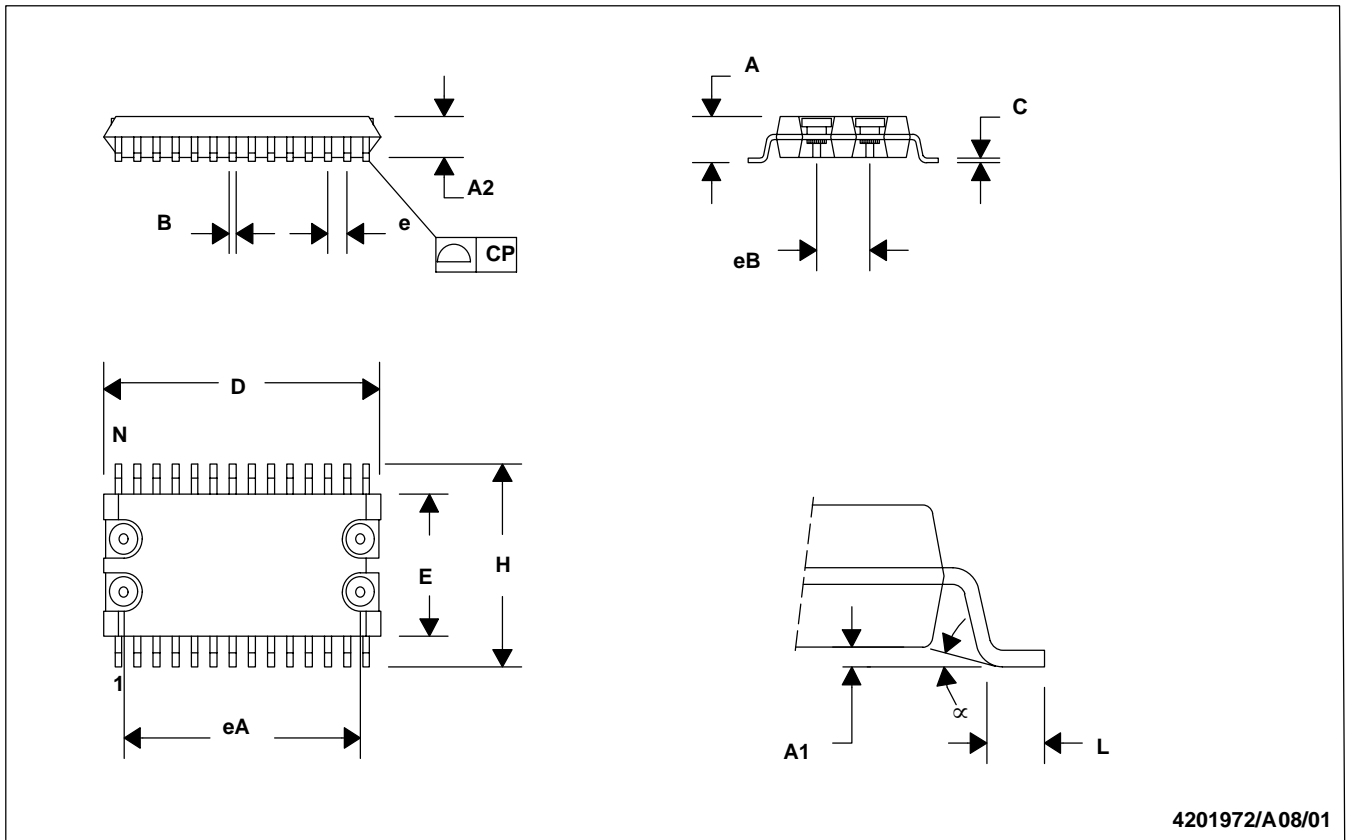

4201972/A08/01

DIMENSION	INCHES		MILLIMETERS	
	MIN	MAX	MIN	MAX
A	–	0.120	–	3,05
A1	0.002	0.014	0,05	0,36
A2	0.092	0.106	2,34	2,69
B	0.014	0.020	0,36	0,51
C	0.006	0.012	0,15	0,30
D	0.697	0.728	17,70	18,49
E	0.324	0.350	8,23	8,89
e	0.050 TYP		1,27 TYP	
eA	0.612	0.628	15,54	15,95
eB	0.126	0.142	3,20	3,61
H	0.453	0.500	11,51	12,70
L	0.016	0.050	0,41	1,27
alpha	0°	8°	0°	8°
N	28		28	
CP	–	0.004	–	0,10

NOTES:A. All linear dimensions are in millimeters.  
B. This drawing is subject to change without notice.

**PACKAGING INFORMATION**

Orderable Device	Status <sup>(1)</sup>	Package Type	Package Drawing	Pins	Package Qty	Eco Plan <sup>(2)</sup>	Lead/Ball Finish	MSL Peak Temp <sup>(3)</sup>
BQ4802LYDSH	ACTIVE	SOP	DSH	28	27	TBD	CU SNPB	Level-2-220C-1 YEAR
BQ4802LYDW	ACTIVE	SOIC	DW	28	20	Green (RoHS & no Sb/Br)	CU NIPDAU	Level-1-260C-UNLIM
BQ4802LYDWR	ACTIVE	SOIC	DW	28	1000	Green (RoHS & no Sb/Br)	CU NIPDAU	Level-1-260C-UNLIM
BQ4802LYPW	ACTIVE	TSSOP	PW	28	50	TBD	CU NIPDAU	Level-2-220C-1 YEAR
BQ4802LYPWR	ACTIVE	TSSOP	PW	28	2000	TBD	CU NIPDAU	Level-2-220C-1 YEAR
BQ4802LYPWRG4	ACTIVE	TSSOP	PW	28	2000	TBD	CU NIPDAU	Level-2-220C-1 YEAR
BQ4802YDSH	ACTIVE	SOP	DSH	28	27	TBD	CU SNPB	Level-2-220C-1 YEAR
BQ4802YDW	ACTIVE	SOIC	DW	28	20	Green (RoHS & no Sb/Br)	CU NIPDAU	Level-1-260C-UNLIM
BQ4802YDWR	ACTIVE	SOIC	DW	28	1000	Green (RoHS & no Sb/Br)	CU NIPDAU	Level-1-260C-UNLIM
BQ4802YDWRG4	ACTIVE	SOIC	DW	28	1000	Green (RoHS & no Sb/Br)	CU NIPDAU	Level-1-260C-UNLIM
BQ4802YPW	ACTIVE	TSSOP	PW	28	50	TBD	CU NIPDAU	Level-2-220C-1 YEAR
BQ4802YPWR	ACTIVE	TSSOP	PW	28	2000	TBD	CU NIPDAU	Level-2-220C-1 YEAR
BQ4802YPWRG4	ACTIVE	TSSOP	PW	28	2000	TBD	CU NIPDAU	Level-2-220C-1 YEAR

<sup>(1)</sup> The marketing status values are defined as follows:

**ACTIVE:** Product device recommended for new designs.

**LIFEBUY:** TI has announced that the device will be discontinued, and a lifetime-buy period is in effect.

**NRND:** Not recommended for new designs. Device is in production to support existing customers, but TI does not recommend using this part in a new design.

**PREVIEW:** Device has been announced but is not in production. Samples may or may not be available.

**OBSOLETE:** TI has discontinued the production of the device.

<sup>(2)</sup> Eco Plan - The planned eco-friendly classification: Pb-Free (RoHS) or Green (RoHS & no Sb/Br) - please check <http://www.ti.com/productcontent> for the latest availability information and additional product content details.

**TBD:** The Pb-Free/Green conversion plan has not been defined.

**Pb-Free (RoHS):** TI's terms "Lead-Free" or "Pb-Free" mean semiconductor products that are compatible with the current RoHS requirements for all 6 substances, including the requirement that lead not exceed 0.1% by weight in homogeneous materials. Where designed to be soldered at high temperatures, TI Pb-Free products are suitable for use in specified lead-free processes.

**Green (RoHS & no Sb/Br):** TI defines "Green" to mean Pb-Free (RoHS compatible), and free of Bromine (Br) and Antimony (Sb) based flame retardants (Br or Sb do not exceed 0.1% by weight in homogeneous material)

<sup>(3)</sup> MSL, Peak Temp. -- The Moisture Sensitivity Level rating according to the JEDEC industry standard classifications, and peak solder temperature.

**Important Information and Disclaimer:**The information provided on this page represents TI's knowledge and belief as of the date that it is provided. TI bases its knowledge and belief on information provided by third parties, and makes no representation or warranty as to the accuracy of such information. Efforts are underway to better integrate information from third parties. TI has taken and continues to take reasonable steps to provide representative and accurate information but may not have conducted destructive testing or chemical analysis on incoming materials and chemicals. TI and TI suppliers consider certain information to be proprietary, and thus CAS numbers and other limited information may not be available for release.

In no event shall TI's liability arising out of such information exceed the total purchase price of the TI part(s) at issue in this document sold by TI to Customer on an annual basis.

DW (R-PDSO-G28)

PLASTIC SMALL-OUTLINE PACKAGE

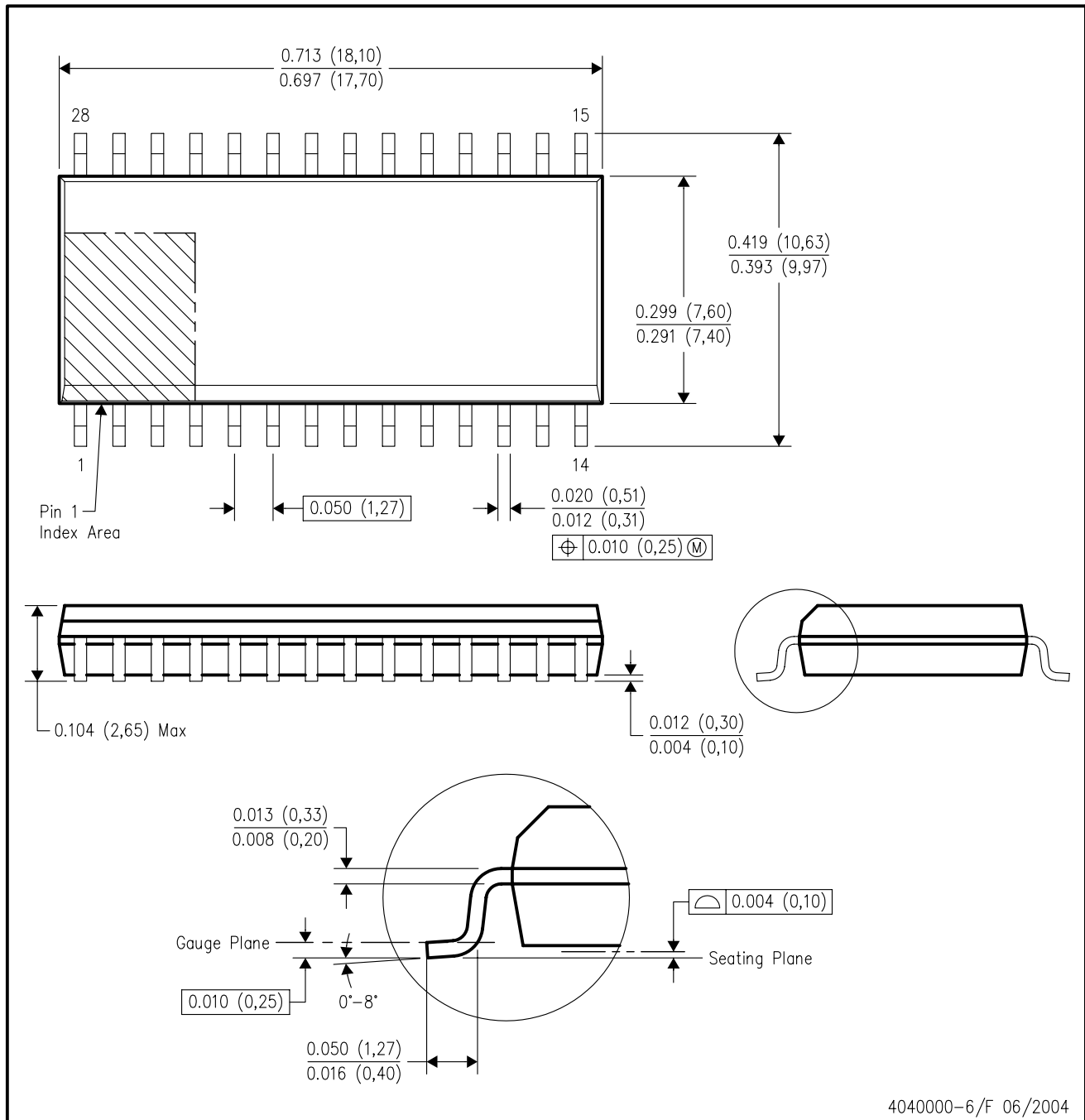

4040000-6/F 06/2004

- NOTES:
- A. All linear dimensions are in inches (millimeters).
  - B. This drawing is subject to change without notice.
  - C. Body dimensions do not include mold flash or protrusion not to exceed 0.006 (0,15).
  - D. Falls within JEDEC MS-013 variation AE.

PW (R-PDSO-G\*\*)

PLASTIC SMALL-OUTLINE PACKAGE

14 PINS SHOWN



4040064/F 01/97

- NOTES: A. All linear dimensions are in millimeters.  
 B. This drawing is subject to change without notice.  
 C. Body dimensions do not include mold flash or protrusion not to exceed 0,15.  
 D. Falls within JEDEC MO-153

## IMPORTANT NOTICE

Texas Instruments Incorporated and its subsidiaries (TI) reserve the right to make corrections, modifications, enhancements, improvements, and other changes to its products and services at any time and to discontinue any product or service without notice. Customers should obtain the latest relevant information before placing orders and should verify that such information is current and complete. All products are sold subject to TI's terms and conditions of sale supplied at the time of order acknowledgment.

TI warrants performance of its hardware products to the specifications applicable at the time of sale in accordance with TI's standard warranty. Testing and other quality control techniques are used to the extent TI deems necessary to support this warranty. Except where mandated by government requirements, testing of all parameters of each product is not necessarily performed.

TI assumes no liability for applications assistance or customer product design. Customers are responsible for their products and applications using TI components. To minimize the risks associated with customer products and applications, customers should provide adequate design and operating safeguards.

TI does not warrant or represent that any license, either express or implied, is granted under any TI patent right, copyright, mask work right, or other TI intellectual property right relating to any combination, machine, or process in which TI products or services are used. Information published by TI regarding third-party products or services does not constitute a license from TI to use such products or services or a warranty or endorsement thereof. Use of such information may require a license from a third party under the patents or other intellectual property of the third party, or a license from TI under the patents or other intellectual property of TI.

Reproduction of information in TI data books or data sheets is permissible only if reproduction is without alteration and is accompanied by all associated warranties, conditions, limitations, and notices. Reproduction of this information with alteration is an unfair and deceptive business practice. TI is not responsible or liable for such altered documentation.

Resale of TI products or services with statements different from or beyond the parameters stated by TI for that product or service voids all express and any implied warranties for the associated TI product or service and is an unfair and deceptive business practice. TI is not responsible or liable for any such statements.

Following are URLs where you can obtain information on other Texas Instruments products and application solutions:

<b>Products</b>		<b>Applications</b>	
Amplifiers	<a href="http://amplifier.ti.com">amplifier.ti.com</a>	Audio	<a href="http://www.ti.com/audio">www.ti.com/audio</a>
Data Converters	<a href="http://dataconverter.ti.com">dataconverter.ti.com</a>	Automotive	<a href="http://www.ti.com/automotive">www.ti.com/automotive</a>
DSP	<a href="http://dsp.ti.com">dsp.ti.com</a>	Broadband	<a href="http://www.ti.com/broadband">www.ti.com/broadband</a>
Interface	<a href="http://interface.ti.com">interface.ti.com</a>	Digital Control	<a href="http://www.ti.com/digitalcontrol">www.ti.com/digitalcontrol</a>
Logic	<a href="http://logic.ti.com">logic.ti.com</a>	Military	<a href="http://www.ti.com/military">www.ti.com/military</a>
Power Mgmt	<a href="http://power.ti.com">power.ti.com</a>	Optical Networking	<a href="http://www.ti.com/opticalnetwork">www.ti.com/opticalnetwork</a>
Microcontrollers	<a href="http://microcontroller.ti.com">microcontroller.ti.com</a>	Security	<a href="http://www.ti.com/security">www.ti.com/security</a>
		Telephony	<a href="http://www.ti.com/telephony">www.ti.com/telephony</a>
		Video & Imaging	<a href="http://www.ti.com/video">www.ti.com/video</a>
		Wireless	<a href="http://www.ti.com/wireless">www.ti.com/wireless</a>

Mailing Address: Texas Instruments  
Post Office Box 655303 Dallas, Texas 75265