

This is a controlled document.

Hardcopy to be endorsed by authorized person.

Check with Issuing Office or SAP system for latest update.

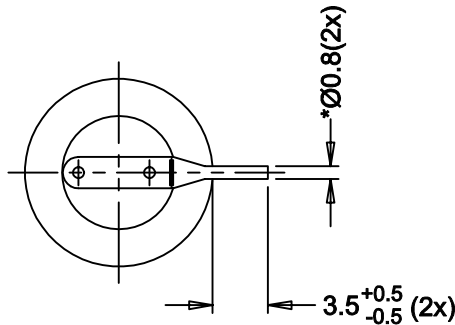
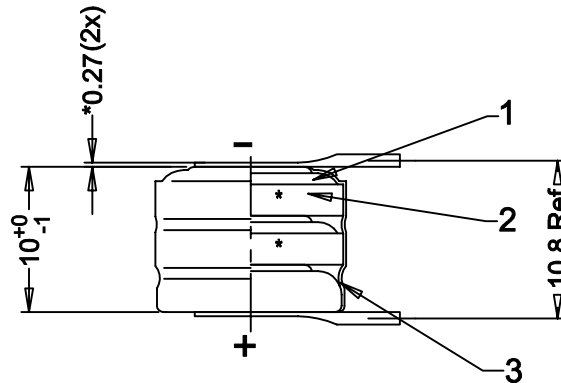
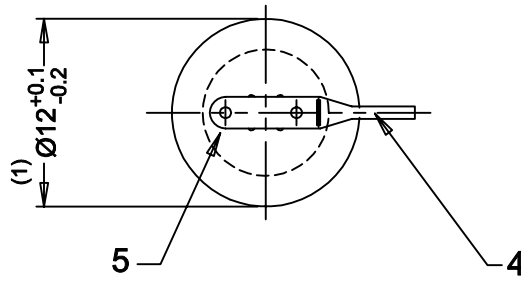

Note : 1) Special care to be taken ie: NOT to mix the polarities

2) *Dimensions for reference only

No.	Alterations:	Date:	Name:	Dimensions in mm	Material:
1	AO 329/00; to change width Ø12 +0.1/-0.2mm was max Ø12.4 mm	2000-12-21	Ratna	Tolerance: As Specified	Refer to part list no: 071068
				Projection:	Description: 3/V15H battery with shrink sleeve & terminal pins
				Scale: 2 : 1	
				Date: Name:	
				Prepared: 1998-03-06 TitisWS	
				Approved: 2001-	
RIGHTS RESERVED TO MAKE TECHNICAL CHANGES, AS A RESULT OF FURTHER DEVELOPMENT, WITHOUT NOTICE. THIS DRAWING IS THE PROPERTY OF VARTA BATTERIES PTE LTD AND MUST NOT BE COPIED OR DISCLOSED TO A THIRD PARTY WITHOUT THE WRITTEN CONSENT OF VARTA BATTERIES PTE LTD.					Dwg. No: 071068
					VKB Order No: 55602 303 013
					Orig No:

4 0 1