



FEATURES

- RoHS compliant
- UL60950 recognized
- Power density up to 0.42W/cm³
- Wide temperature performance at full 1 watt load, -40°C to 60°C
- Dual outputs
- UL 94V-0 package material
- No heatsink required
- Footprint 1.91cm²
- SIP package style
- Power sharing
- 5.2kVDC isolation
- 5V & 12V input
- 5V, 9V, 12V and 15V output
- Internal SMD construction
- Fully encapsulated with toroidal magnetics
- Pin compatible with dual output versions of the NMV series SIP DC/DC converters
- MTTF up to 1.5 million hours
- Custom solutions available

DESCRIPTION

The NMJ series are dual output DC/DC converters in a 7 pin SIP package style offering pin and functionality compatibility with the NMV series SIP DC/DC converters. The NMJ series is UL60950 recognized and suitable for applications where safety and miniaturisation are of paramount importance.

SELECTION GUIDE

Order Code	Nominal Input Voltage	Output Voltage	Output Current	Efficiency	Isolation Capacitance	MTTF ¹
	(V)	(V)	(mA)	%	pF	kHrs
NMJ0505SC	5	±5	±100	64	1.6	1517
NMJ0509SC	5	±9	±55	68	1.6	619
NMJ0512SC	5	±12	±42	69	1.8	313
NMJ0515SC	5	±15	±33	71	1.9	172
NMJ1205SC	12	±5	±100	69	1.8	456
NMJ1209SC	12	±9	±55	75	1.9	318
NMJ1212SC	12	±12	±42	75	2.0	211
NMJ1215SC	12	±15	±33	76	2.1	136

When operated **with** additional external load capacitance the rise time of the input voltage will determine the maximum external capacitance value for guaranteed start up. The slower the rise time of the input voltage the greater the maximum value of the additional external capacitance for reliable start up.

INPUT CHARACTERISTICS

Parameter	Conditions	MIN.	TYP.	MAX.	Units
Voltage range	Continuous operation, 5V input types	4.5	5	5.5	V
	Continuous operation, 12V input types	10.8	12	13.2	

OUTPUT CHARACTERISTICS

Parameter	Conditions	MIN.	TYP.	MAX.	Units
Rated Power ²	T _A = -40°C to 60°C			1	W
Voltage Set Point Accuracy	See tolerance envelope	-7.5		10	%
Line regulation	High V _{IN} to low V _{IN}		1.0	1.2	%/%
	10% load to rated load, 5V output types		10	15	
Load Regulation	10% load to rated load, 9V output types		6.0	10	%
	10% load to rated load, 12V output types		6.0	10	
	10% load to rated load, 15V output types		6.0	10	
Ripple and Noise	BW=DC to 20MHz, all output types			200	mV p-p
Zero Load Power Consumption	5V output types		290		mW
	12V output types		220		

ISOLATION CHARACTERISTICS

Parameter	Conditions	MIN.	TYP.	MAX.	Units
Isolation test voltage	Flash tested for 1 second	5200			VDC
Resistance	Viso = 500VDC		1		GΩ

GENERAL CHARACTERISTICS

Parameter	Conditions	MIN.	TYP.	MAX.	Units
Switching frequency			70		kHz

ABSOLUTE MAXIMUM RATINGS

Short-circuit protection ³	1 second
Lead temperature 1.5mm from case for 10 seconds	300°C
Input voltage V _{IN} , NMJ05 types	7V
Input voltage V _{IN} , NMJ12 types	15V

1. Calculated using MIL-HDBK-217F with nominal input voltage at full load.

2. See derating graph.

3. Supply voltage must be discontinued at the end of the short circuit duration.

All specifications typical at T_A = 25°C, nominal input voltage and rated output current unless otherwise specified.



TEMPERATURE CHARACTERISTICS					
Parameter	Conditions	MIN.	TYP.	MAX.	Units
Specification	All output types	-40		60	°C
Storage		-55		130	
Case Temperature above ambient	All output types			33	
Cooling	Free air convection				

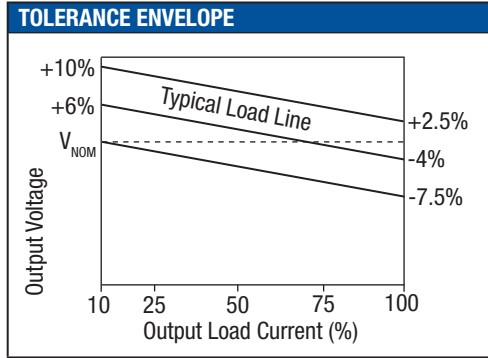
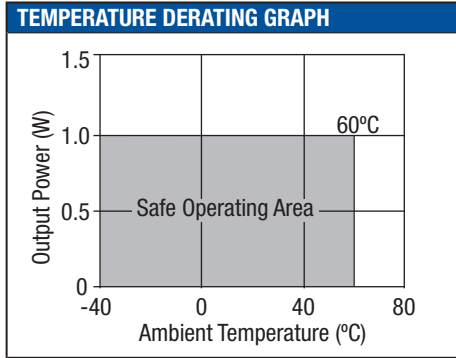

SAFETY APPROVAL

The NMJ series has been recognised by Underwriters Laboratory (UL) to UL 60950 for supplementary insulation up to 300Vrms and reinforced insulation up to 150Vrms working voltage at a maximum ambient temperature of 60°C. File number E179522 applies.

TECHNICAL NOTES

ISOLATION VOLTAGE

'Hi Pot Test', 'Flash Tested', 'Withstand Voltage', 'Proof Voltage', 'Dielectric Withstand Voltage' & 'Isolation Test Voltage' are all terms that relate to the same thing, a test voltage, applied for a specified time, across a component designed to provide electrical isolation, to verify the integrity of that isolation.

C&D Technologies NMJ series of dc/dc converters are all 100% production tested at their stated isolation voltage. This is 5.2kVDC for 1 second.

A question commonly asked is, "What is the continuous voltage that can be applied across the part in normal operation?"

The NMJ series has been recognized by Underwriters Laboratory to a working voltage of 300Vrms for Supplementary Insulation system and 150Vrms for Reinforced Insulation systems.

REPEATED HIGH-VOLTAGE ISOLATION TESTING

It is well known that repeated high-voltage isolation testing of a barrier component can actually degrade isolation capability, to a lesser or greater degree depending on materials, construction and environment. The NMJ series have toroidal isolation transformers, with an additional insulation system between the enameled wire primary and secondary windings. While manufactured parts can withstand several times the stated test voltage, the isolation capability does depend on the wire insulation. Any material, including this enamel (typically polyurethane) is susceptible to eventual chemical degradation when subject to very high applied voltages thus implying that the number of tests should be strictly limited. We therefore strongly advise against repeated high voltage isolation testing, but if it is absolutely required, that the voltage be reduced by 20% from specified test voltage.

PACKAGE SPECIFICATIONS

MECHANICAL DIMENSIONS

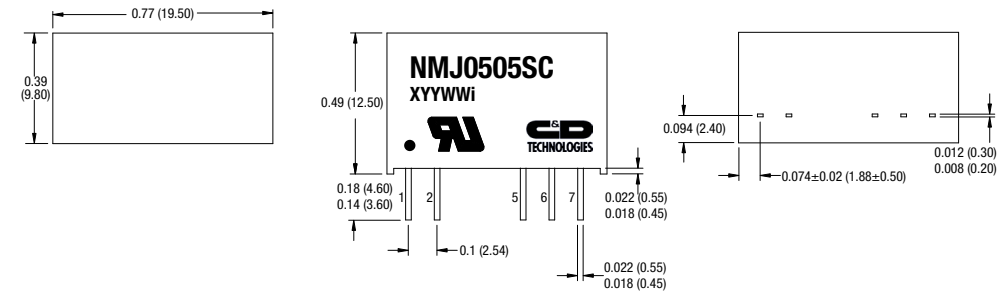

All dimensions in inches ±0.01 (mm ±0.25mm). All pins on a 0.1 (2.54) pitch and within ±0.01 (0.25) of true position.

Weight: 4.3g

PIN CONNECTIONS - 7 PIN SIP

Pin	Function
1	+VIN
2	-VIN
5	-VOUT
6	OV
7	+VOUT

RECOMMENDED FOOTPRINT DETAILS

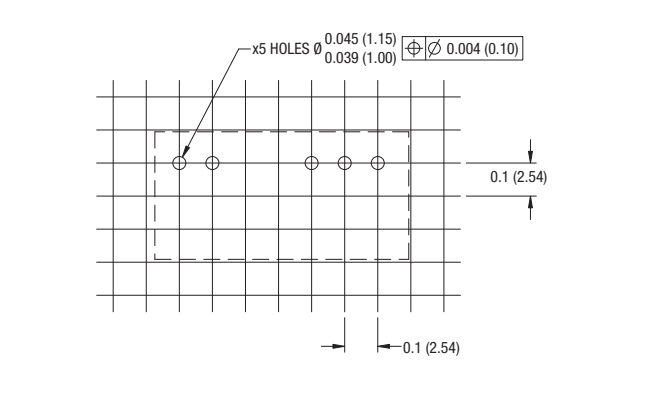

TUBE OUTLINE DIMENSIONS

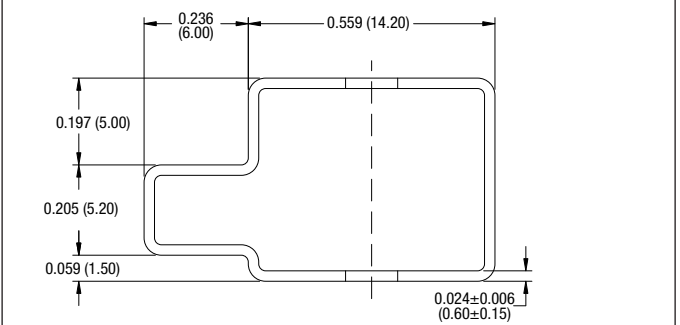

Unless otherwise stated all dimensions in inches ±0.02 (mm ±0.5mm).

Tube length : 20.669±0.079 (525mm±2mm).

Tube Quantity : 25

RoHS COMPLIANT INFORMATION



This series is compatible with RoHS soldering systems with a peak wave solder temperature of 300°C for 10 seconds. The pin termination finish on this product series is Tin Plate, Hot Dipped over Matte Tin with Nickel Preplate. The series is backward compatible with Sn/Pb soldering systems.

For further information, please visit www.cd4power.com/rohs