

Delivery address: Mackenrodtstraße 14,
36039 Fulda, Germany
Postal address: 36035 Fulda, Germany
Phone: +49 661 6003-0
Fax: +49 661 6003-607
e-mail: mail@jumo.net
Internet: www.jumo.net

JUMO House
Temple Bank, Riverway
Harlow, Essex CM 20 2TT, UK
Phone: +44 1279 635533
Fax: +44 1279 635262
e-mail: sales@jumo.co.uk
Internet: www.jumo.co.uk

885 Fox Chase, Suite 103
Coatesville PA 19320, USA
Phone: 610-380-8002
1-800-554-JUMO
Fax: 610-380-8009
e-mail: info@JumoUSA.com
Internet: www.JumoUSA.com



JUMO di eco

**Digital Temperature Indicator,
microprocessor-controlled,
with 10A changeover relay,
in 76mm x 36mm format**



Brief description

The JUMO di eco compact digital indicator is used for visualizing temperatures which are acquired through Pt100, Pt1000 or KTY2X-6 resistance thermometers in a 2-wire circuit. The measurement is shown on a 3-digit display with red background lighting. Limit infringements can be monitored by means of a 10A changeover relay and signaled via an LED.

From the 3 buttons on the front panel it is possible to configure, among others, the switching differential and alarm suppression.

The electrical connection is made via screw terminals on the back of the instrument.



Type 951540/...

Block structure

Measurement input (configurable)

- Pt100
- Pt1000
- KTY2X-6
- in 2-wire circuit

Supply

- 230 V AC +10/-15 %
- 115 V AC +10/-15 %
- 24 V DC +15/-15 %
- 12 V DC +15/-15 %



Output

- floating changeover relay
- 10 A 250 V AC
- resistive load

LC display

- 3-digit display with background lighting for visualization of temperature and parameters

Features

- Limit monitoring with a 10A changeover relay
- Adjustable switching differential
- Configurable alarm suppression
- Symbols for temperature unit, minutes and seconds in display
- Parameter level protected by code
- Each parameter can be enabled individually for operation
- Simple mounting
- Programmable switch-on delay after power ON
- UL approval applied for

Displays and controls

LC display	3-digit segment display, 13 mm high, with symbols for °C, °F, min and s, with red background lighting
LED K1	LED K1 flashes during alarm suppression period LED K1 comes on when limits are infringed or on a probe error
Buttons	<ul style="list-style-type: none"> (P) programming (▲) increase parameter value (▼) decrease parameter value (P) + (▲) version display (P) + (▼) exit, jump to basic status (temperature indication)



Technical data

Measurement input

Designation	Range	Accuracy ¹	Over/underrange
Pt100 EN 60 751	-200 to +500 °C	0.1 %	is recognized
Pt1000 EN 60 751	-200 to +500 °C	0.1 %	is recognized
KTY2X-6	-50 to 150 °C	1 %	is recognized
Sampling time	250 msec		
Input filter	1st order digital filter; filter constant adjustable from 0 – 99.9sec		
Lead compensation	adjustable via the parameter Lead compensation resistance $\sigma_{F,r}$		
Temperature offset	adjustable via the parameter $\sigma_{F,t}$		
Features	temperature display °C or °F (Fahrenheit)		

¹ The accuracy refers to the maximum range span

Environmental effects

Ambient temperature range	0 to +55 °C
Ambient temperature range for side-by-side mounting	0 to +40 °C
Storage temperature range	-40 to +70 °C
Temperature drift	≤100ppm/°C of range
Climatic conditions	≤75 % relative humidity, no condensation
Care of the front panel	The front panel can be cleaned with all the usual washing and rinsing agents. Do not use any solvents such as methylated spirits, white spirit, P1 or xylol!

Output

Relay	150,000 operations at 10A 250V AC resistive load 800,000 operations at 3A 250V AC resistive load
-------	---

Supply

Supply voltage	230V AC +10/-15 %, 115V AC +10/-15 %, 24V DC +15/-15 %, 12V DC +15/-15 %
Power consumption	<3VA

Housing

Material	polycarbonate
Mounting	in panel cut-out with bezel seal
Operating position	unrestricted
Weight	approx. 160g
Enclosure protection	front IP65, back IP20
Flammability class	UL 94 V0

Electrical data

Data backup	EEPROM
Connection circuit	via screw terminals for wire cross-sections up to 4 mm ² solid wire and 2.5 mm ² stranded wire
EMC - interference emission - immunity to interference	EN 61 326 Class B to industrial requirements
Electrical safety	to EN 61 010, Part 1 overvoltage category III, pollution degree 2

Connection diagram

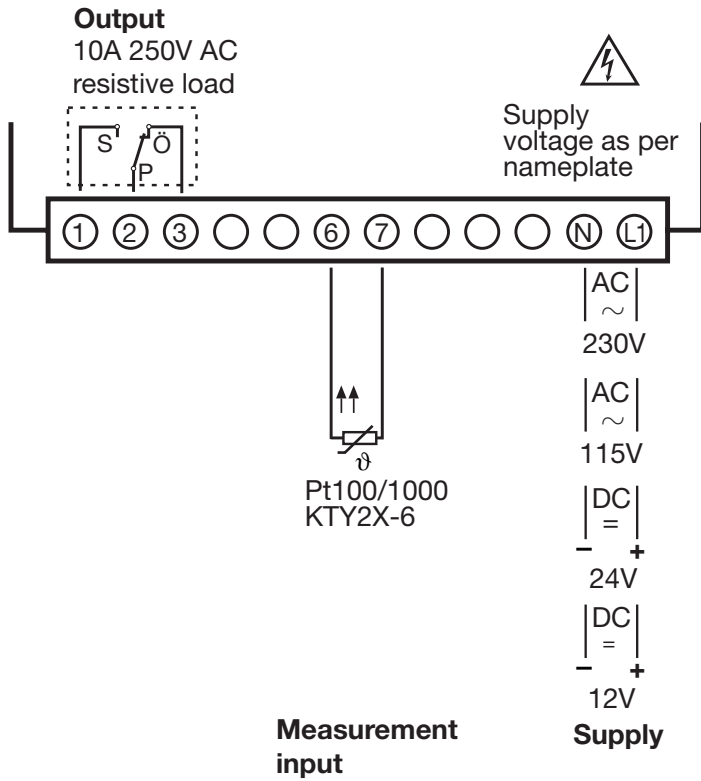

Dimensions

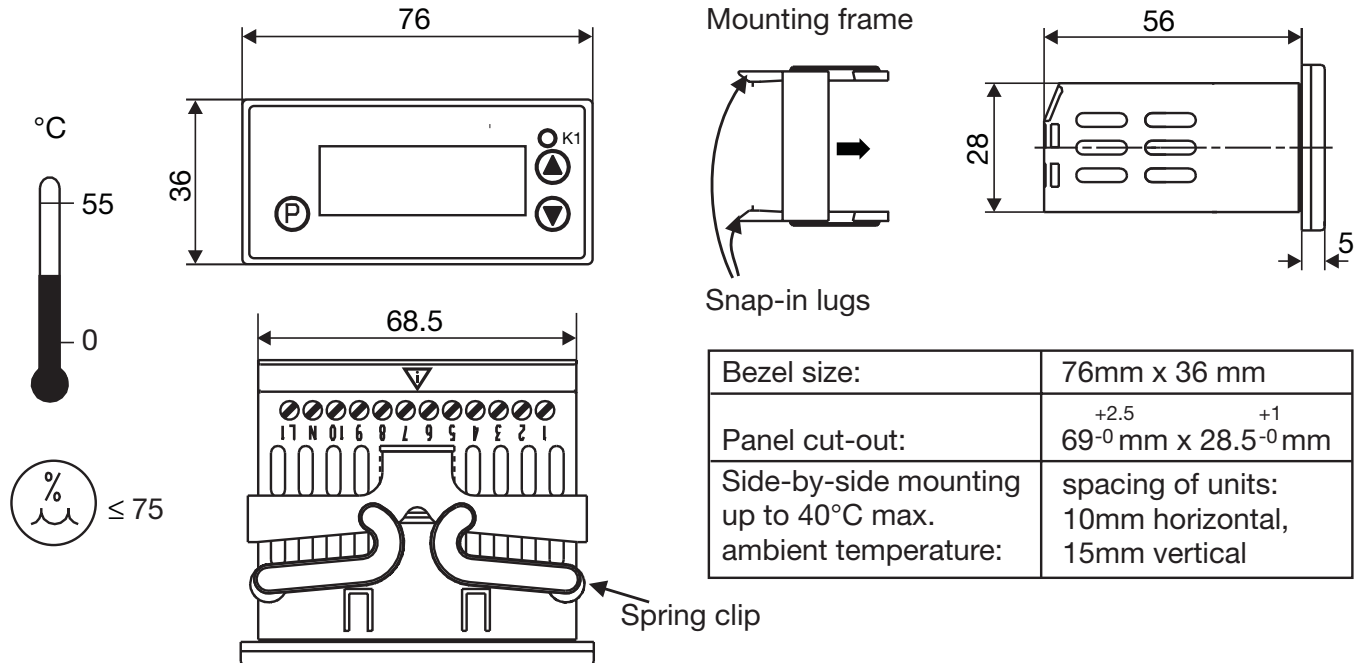

Order details: Digital Temperature Indicator,
microprocessor-controlled, with 10A changeover relay, in 76mm x 36 mm format

(1) Basic version

951540/ JUMO di eco

(2) Input (configurable)

x	888	factory-set (Pt100 in 2-wire circuit)
x	999	configuration to customer specification (Pt1000 in 2-wire circuit or KTY2X-6) ¹

(3) Supply

x	02	230V AC +10/-15 %, 48 – 63Hz
x	05	115V AC +10/-15 %, 48 – 63Hz
x	18	24V DC +15/-15 %
x	20	12V DC +15/-15 %

Order code (1) (2) (3)
Order example 951540 / 888 - 02

¹ For configuration to customer specification, please specify the probe type and the required settings in plain text

Standard accessories

- 1 Operating Instructions B 95.1540.0
- 1 mounting frame
- 1 bezel seal