

AFBR-5601Z and AFCT-5611Z

Gigabit Interface Converters (GIC) for Gigabit Ethernet



Data Sheet

Description

The AFBR-56xxZ/AFCT-56xxZ family of interface converters meet the Gigabit Interface Converter specification Rev. 5.4, an industry standard. The family provides a uniform form factor for a wide variety of standard connections to transmission media. The converters can be inserted or removed from a host chassis without removing power from the host system.

The converters are suitable for interconnections in the Gigabit Ethernet hubs and switches environment. The design of these converters is also practical for other high performance, point-to-point communication requiring gigabit interconnections. Since the converters are hot-pluggable, they allow system configuration changes simply by plugging in a different type of converter.

The mechanical and electrical interfaces of these converters to the host system are identical for all implementations of the converter regardless of external media type. A 20-pin connector is used to connect the converter to the host system. Surge currents are eliminated by using pin sequencing at this connector and a slow start circuit. Two ground tabs at this connector also make contact before any other pins, discharging possible component-damaging static electricity. In addition, the connector itself performs a two-stage contact sequence. Operational signals and power supply ground make contact in stage 1 while power makes contact in stage 2.



Features

- RoHS Compliance
- Compliant with Gigabit Interface Converter specification Rev. 5.4 (1)
- AFBR-5601Z is compliant with proposed specifications for IEEE 802.3z/D5.0 Gigabit Ethernet (1000 Base-SX)
- AFCT-5611Z is compliant with the ANSI 100-SM-LC-L revision 2 10 km link specification
- Performance:
 - AFBR-5601Z:
 - 500 m with 50/125 μ m MMF
 - 220 m with 62.5/125 μ m MMF
 - AFCT-5611Z:
 - 550 m with 50/125 μ m MMF
 - 550 m with 62.5/125 μ m MMF
 - 10 km with 9/125 μ m SMF
- Horizontal or vertical installation
- AEL Laser Class 1 eye safe per IEC 60825-1
- AEL Laser Class I eye safe per US 21 CFR
- Hot-pluggable

Related Products

- 850 nm VCSEL, 1 x 9 and SFF transceivers for 1000 base SX applications (AFBR-53D5, HFBR-5912E)
- 1300 nm, 1 x 9 Laser transceiver for 1000 base-LX applications (HFCT-53D5)
- Physical layer ICs available for optical interface (HDMP-1636A/46A)

Applications

- Switch to switch interface
- High speed I/O for file servers
- Bus extension applications

The AFBR-5601Z has been developed with 850 nm short wavelength VCSEL technology while the AFCT-5611Z is based on 1300 nm long wavelength Fabry Perot laser technology.

The AFBR-5601Z complies with Annex G of the GBIC specification Revision 5.4. In the 1000BASE-SX environment the AFBR-5601Z achieves 220 m transmission distance with 62.5 μm and 500 m with 50 μm multimode fiber respectively.

The AFCT-5611Z complies with Annex F of the GBIC specification Revision 5.4 and reaches 10 km with 9/125 μm single mode fiber. Both the AFBR-5601 and the AFCT-5611Z are Class 1 Eye Safe laser devices.

Serial Identification

The AFBR-56xx and AFCT-5611Z family complies with Annex D (Module Definition 4) of the GBIC specification Revision 5.4, which defines the Serial Identification Protocol.

Definition 4 specifies a serial definition protocol. For this definition, upon power up, MOD_DEF(1:2) (Pins 5 and 6 on the 20-pin connector) appear as NC. Pin 4 is TTL ground. When the host system detects this condition, it activates the public domain serial protocol. The protocol uses the 2-wire serial CMOS E²PROM protocol of the ATMEL AT24C01A or similar.

The data transfer protocol and the details of the mandatory and vendor specific data structures are defined in Annex D of the GBIC specification Revision 5.4.

Regulatory Compliance

See the Regulatory Compliance Table for the targeted typical and measured performance for these transceivers.

The overall equipment design will determine the level it is able to be certified to. These transceiver performance targets are offered as a figure of merit to assist the designer in considering their use in equipment designs.

Electrostatic Discharge (ESD)

There are two design cases in which immunity to ESD damage is important.

The first case is during handling of the transceiver prior to inserting it into the host system. It is important to use normal ESD handling precautions for ESD sensitive devices. These precautions include using grounded wrist straps, workbenches, and floor mats in ESD controlled areas.

The second case to consider is static discharges during insertion of the GBIC into the host system. There are two guide tabs integrated into the 20-pin connector on the GBIC. These guide tabs are connected to circuit ground. When the GBIC is inserted into the host system, these tabs will engage before any of the connector pins. The mating connector in the host system must have its tabs connected to circuit ground. This discharges any stray static charges and establishes a reference for the power supplies that are sequenced later.

Electromagnetic Interference (EMI)

Most equipment designs utilizing these high-speed transceivers from Avago will be required to meet the requirements of FCC in the United States, CENELEC EN55022 (CISPR 22) in Europe and VCCI in Japan.

Immunity

Equipment utilizing these transceivers will be subject to radio-frequency electromagnetic fields in some environments. These transceivers have good immunity to such fields due to their shielded design.

Customer Manufacturing Processes

This module is pluggable and is not designed for aqueous wash, IR reflow or wave soldering processes.

Eye Safety

Laser-based GBIC transceivers provide Class 1 (IEC 60825-1) and Class I (US 21 CFR [J]) laser eye safety by design. Avago has tested the current transceiver design for compliance with the requirements listed below under normal operating conditions and for compliance under single fault conditions.

Outline Drawing

An outline drawing is shown in Figure 1. More detailed drawings are shown in Gigabit Interface Converter specification Rev. 5.4.

Note: AFBR-5601 is non-compliant for Tx fault timing.

GBIC Serial ID Memory Contents - AFBR-5601Z

Addr	Hex	ASCII	Addr	Hex	ASCII	Addr	Hex	ASCII	Addr	Hex	ASCII
0	1		40	41	A	68	39	9	96	20	
1	7		41	46	F	69	38	8	97	20	
2	1		42	42	B	70	30	0	98	20	
3	0		43	52	R	71	36	6	99	20	
4	0		44	2D	-	72	32	2	100	20	
5	0		45	35	5	73	33	3	101	20	
6	1		46	36	6	74	30	0	102	20	
7	0		47	30	0	75	33	3	103	20	
8	0		48	31	1	76	32	2	104	20	
9	0		49	5A	Z	77	38	8	105	20	
10	0		50	20		78	33	3	106	20	
11	1		51	20		79	34	4	107	20	
12	0D		52	20		80	33	3	108	20	
13	0		53	20		81	37	7	109	20	
14	0		54	20		82	33	3	110	20	
15	0		55	20		83	30	0	111	20	
16	32		56	30	0	84	39	9	112	20	
17	16		57	30	0	85	38	8	113	20	
18	0		58	30	0	86	30	0	114	20	
19	0		59	30	0	87	36	6	115	20	
20	41	A	60	0		88	32	2	116	20	
21	47	G	61	0		89	33	3	117	20	
22	49	I	62	0		90	30	0	118	20	
23	4C	L	63	74		91	30	0	119	20	
24	45	E	64	0		92	0		120	20	
25	4E	N	65	1A		93	0		121	20	
26	54	T	66	0		94	0		122	20	
27	20		67	0		95	F3		123	20	
28	20								124	20	
29	20								125	20	
30	20								126	20	
31	20								127	20	
32	20										
33	20										
34	20										
35	20										
36	0										
37	00										
38	30										
39	D3										

Note: Blanks in ASCII column are numeric values not ASCII characters.

GBIC Serial ID Memory Contents - AFCT-5611Z

Addr	Hex	ASCII	Addr	Hex	ASCII	Addr	Hex	ASCII	Addr	Hex	ASCII
0	1		40	41	A	68	39	9	96	20	
1	6		41	46	F	69	38	8	97	20	
2	1		42	43	C	70	30	0	98	20	
3	0		43	54	T	71	36	6	99	20	
4	0		44	2D	-	72	32	2	100	20	
5	0		45	35	5	73	33	3	101	20	
6	2		46	36	6	74	30	0	102	20	
7	0		47	31	1	75	33	3	103	20	
8	0		48	31	1	76	34	4	104	20	
9	0		49	5A	Z	77	32	2	105	20	
10	0		50	20		78	30	0	106	20	
11	1		51	20		79	39	9	107	20	
12	0D		52	20		80	34	4	108	20	
13	0		53	20		81	32	2	109	20	
14	0		54	20		82	39	9	110	20	
15	64		55	20		83	30	0	111	20	
16	37		56	30	0	84	39	9	112	20	
17	37		57	30	0	85	38	8	113	20	
18	0		58	30	0	86	30	0	114	20	
19	0		59	30	0	87	36	6	115	20	
20	41	A	60	0		88	32	2	116	20	
21	47	G	61	0		89	33	3	117	20	
22	49	I	62	0		90	30	0	118	20	
23	4C	L	63	3		91	30	0	119	20	
24	45	E	64	0		92	0		120	20	
25	4E	N	65	1A		93	0		121	20	
26	54	T	66	0		94	0		122	20	
27	20		67	0		95	F3		123	20	
28	20								124	20	
29	20								125	20	
30	20								126	20	
31	20								127	20	
32	20										
33	20										
34	20										
35	20										
36	0										
37	00										
38	30										
39	D3										

Note: Blanks in ASCII column are numeric values not ASCII characters.

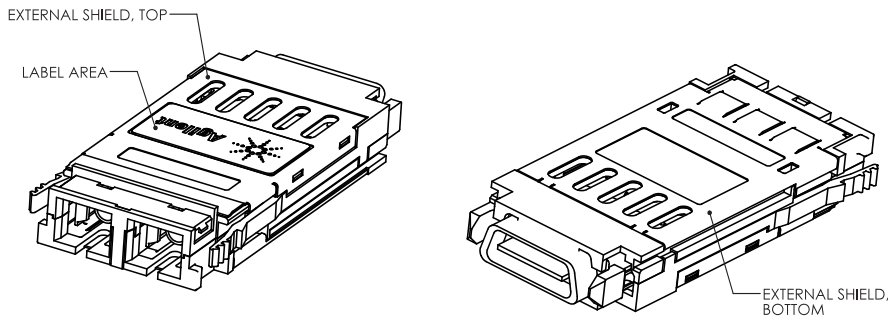
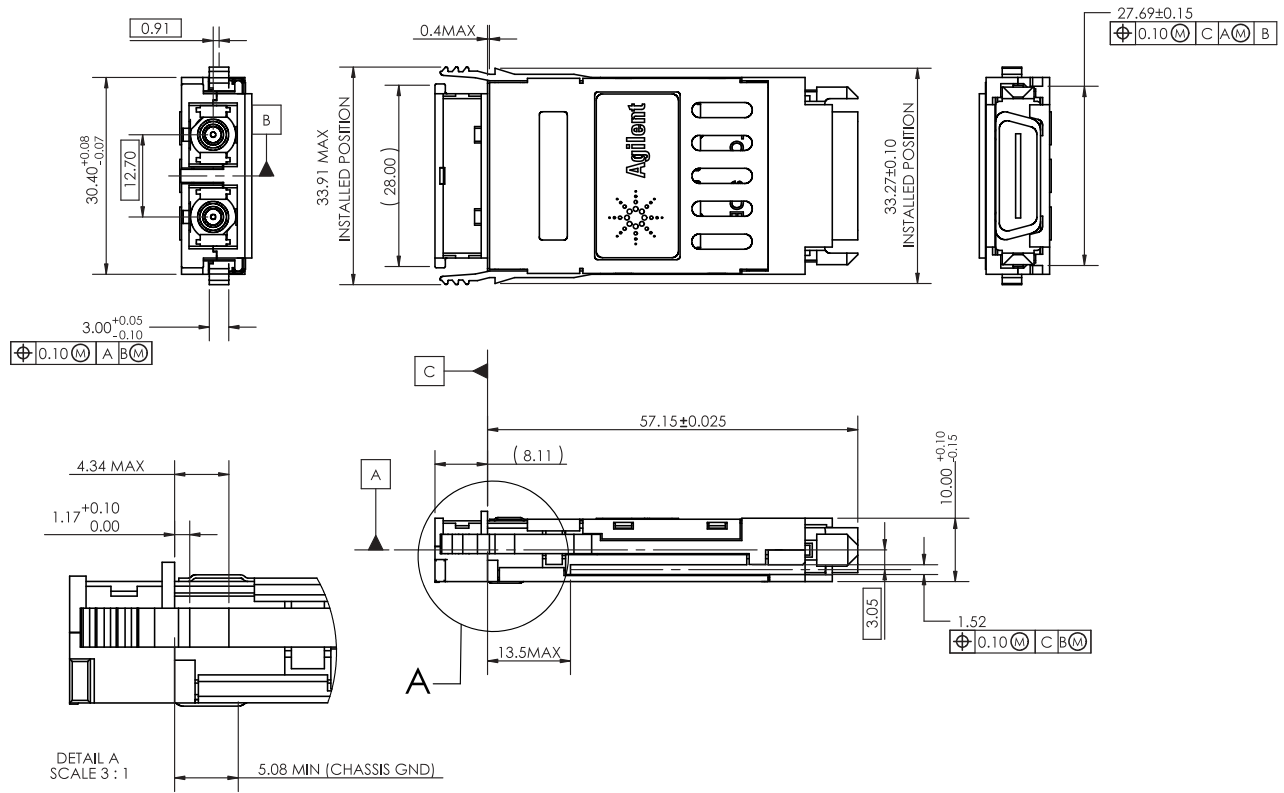

Figure 1. Outline Drawing of AFBR-5601 and AFCT-5611.

Optical Power Budget and

Link Penalties

The worst-case Optical Power Budget (OPB) in dB for a fiber optic link is determined by the difference between the minimum transmitter output optical power (dBm avg) and the lowest receiver sensitivity (dBm avg). This OPB provides the necessary optical signal range to establish a working fiber-optic link. The OPB is allocated for the fiber-optic cable length and the corresponding link penalties. For proper link performance, all penalties that affect the link performance must be accounted for within the link optical power budget. The Gigabit/sec Ethernet (GbE) IEEE 802.3z standard identifies, and has modeled, the contributions of these OPB penalties to establish the link length requirements for 62.5/125 μm and 50/125 μm multimode fiber usage. In addition, single-mode fiber with standard 1300 nm Fabry Perot lasers have been modeled and specified. Refer to IEEE 802.3z standard and its supplemental documents that develop the model, empirical results and final specifications.

10 km Link Support

As well as complying with the LX 5 km standard, the AFCT-56xx specification provides additional margin allowing for a 10 km Gigabit Ethernet link on single mode fiber. This is accomplished by limiting the

spectral width and center wavelength range of the transmitter while increasing the output optical power and improving sensitivity. All other LX cable plant recommendations should be followed.

CAUTION:

There are no user serviceable parts nor any maintenance required for the AFBR-56xx and AFCT-56xx product family. All adjustments are made at the factory before shipment to our customers. Tampering with or modifying the performance of any Avago GBIC unit will result in voided product warranty. It may also result in improper operation of the circuitry, and possible overstress of the semiconductor components. Device degradation or product failure may result.

Connection of either the AFBR-5601Z or the AFCT-5611Z to a non-approved optical source, operating above the recommended absolute maximum conditions, or operating in a manner inconsistent with unit design and function, may result in hazardous radiation exposure and may be considered an act of modifying or manufacturing a laser product. The person(s) performing such an act is required by law to recertify the laser product under the provisions of US 21 CFR (Subchapter J).

Regulatory Compliance

Feature	Test Method	Targeted Performance
Electrostatic Discharge (ESD) to the Electrical Pins	MIL-STD-883C Method 3015.7	Class 1 (>2000 V)
Electrostatic Discharge (ESD) to the Duplex SC Receptacle	Variation of IEC 61000-4-2	Typically withstand at least 15 kV without damage when port is contacted by a Human Body Model probe.
Electromagnetic Interference (EMI)	FCC Class B CENELEC EN55022 Class B (CISPR 22A) VCCI Class 1	Margins are dependent on customer board and chassis design.
Immunity	Variation of IEC 61000-4-3	Typically show no measurable effect from a 10 V/m field swept from 27 to 1000 MHz applied to the transceiver without a chassis enclosure
Laser Eye Safety	US 21 CFR, Subchapter J per paragraphs 1002.10 and 1002.12 EN 60825-1: 1994+A11 EN 60825-2: 1994+A1 EN 60950: 1992+A1+A2+A3+A4+A11	AEL Class I, FDA/CDRH AFBR-5601Z Accession No. 9720151-51 AFCT-5611Z Accession No. 9521220-120 AEL Class 1, TUV Rheinland of North America AFBR-5601Z Certificate No. R72040311.004 AFCT-5611Z Certificate No. 933/21201880/04 Protection Class III
Component Recognition	Underwriters Laboratories and Canadian Standards Association Joint Component Recognition for Information Technology Equipment Including Electrical Business Equipment.	UL File E173874
RoHS Compliance		Less than 1000 ppm of cadmium, lead, mercury, hexavalent chromium, polybrominated biphenyls, and polybrominated biphenyl ethers.

20-Pin SCA-2 Host Connector Characteristics

Table 1. SCA-2 Host connector pin assignment

Pin	Name	Sequence	Pin	Name	Sequence
1	RX_LOS	2	11	RGND	1
2	RGND	2	12	-RX_DAT	1
3	RGND	2	13	+RX_DAT	1
4	MOD_DEF(0)	2	14	RGND	1
5	MOD_DEF(1)	2	15	VDDR	2
6	MOD_DEF(2)	2	16	VDDT	2
7	TX_DISABLE*	2	17	TGND	1
8	TGND	2	18	+TX_DAT	1
9	TGND	2	19	-TX_DAT	1
10	TX_FAULT	2	20	TGND	1

Notes:

A sequence value of 1 indicates that the signal is in the first group to engage during plugging of a module. A sequence value of 2 indicates that the signal is the second and last group. The two guide pins integrated on the connector are connected to TGND. These two guide pins make contact with circuit ground prior to Sequence 1 signals.

* This pin is tied high via 10 K pull-up resistor.

Table 2. Signal Definition

Pin	Signal Name	Input/Output	Description
1	RX_LOS	Output	Receiver Loss of Signal, TTL High, open collector
2	RGND		Receiver Ground
3	RGND		Receiver Ground
4	MOD_DEF(0)	Output	TTL Low
5	MOD_DEF(1)	Input	SCL Serial Clock Signal
6	MOD_DEF(2)	Input/Output	SDA Serial Data Signal
7	TX_DISABLE	Input	Transmit Disable
8	TGND		Transmitter Ground
9	TGND		Transmitter Ground
10	TX_FAULT	Output	Transmit Fault
11	RGND		Receiver Ground
12	-RX_DAT	Output	Received Data, Differential PECL, ac coupled
13	+RX_DAT	Output	Received Data, Differential PECL, ac coupled
14	RGND		Receiver Ground
15	VDDR	Input	Receiver +5 V supply
16	VDDT	Input	Transmitter +5 V supply
17	TGND		Transmitter Ground
18	+TX_DAT	Input	Transmit Data, Differential PECL, ac coupled
19	-TX_DAT	Input	Transmit Data, Differential PECL, ac coupled
20	TGND		Transmitter Ground

Table 3. Module Definition

Defntn.	MOD_DEF(0) Pin 4	MOD_DEF(1) Pin 5	MOD_DEF(2) Pin 6	Interpretation by host
4	TTL Low	SCL	SDA	Serial module definition protocol

Note: All Avago GBIC modules comply with Module Definition 4 of the GBIC specification Rev 5.4

Short Wavelength GBIC: AFBR-5601Z

Transmitter Section

The transmitter section consists of an 850 nm VCSEL in an optical subassembly (OSA), which mates to the fiber cable. The VCSEL OSA is driven by a custom, silicon bipolar IC which converts differential logic signals into an analog Laser Diode drive current.

Receiver Section

The receiver includes a GaAs PIN photodiode mounted together with a custom, silicon bipolar transimpedance preamplifier IC, in an OSA. The OSA interfaces to a custom silicon bipolar circuit that provides post-amplification and quantization. The post-amplifier includes a Signal Detect circuit that provides TTL compatible logic-low output in response to the detection of a usable input optical signal.

Eye Safety Design

The laser driver is designed to be Class 1 eye safe (CDRH21 CFR(J), IEC 60825-1) under a single fault condition. To be eye safe, only one of two results can occur in the event of a single fault. The transmitter must either maintain normal eye safe operation or the transmitter should be disabled.

There are three key elements to the safety circuitry: a monitor diode, a window detector circuit, and direct control of the laser bias. The window detection circuit monitors the average optical power using the monitor diode. If a fault occurs such that the dc regulation circuit cannot maintain the preset bias conditions within $\pm 20\%$, the transmitter will automatically be disabled. Once this has occurred, an electrical power reset will allow an attempted turn-on of the transmitter. TX_FAULT can also be cleared by cycling TX_DISABLE high for a time interval $\geq 10 \mu\text{s}$.

Absolute Maximum Ratings

Stresses in excess of the absolute maximum ratings can cause catastrophic damage to the device. Limits apply to each parameter in isolation, all other parameters having values within the recommended operating conditions. It should not be assumed that limiting values of more than one parameter can be applied to the product at the same time. Exposure to the absolute maximum ratings for extended periods can adversely affect device reliability.

Parameter	Symbol	Min.	Typ.	Max.	Unit	Notes
Storage Temperature	T_S	-40		+85	$^{\circ}\text{C}$	
Supply Voltage	V_{DDT} V_{DDR}	-0.5		6.0	V	
Data Input Voltage	TX_DAT	-0.5		V_{DDT}	V	1
Transmitter Differential Input Voltage	$\pm\text{TX_DAT}$			2000	mV p-p	
Relative Humidity	RH	5		95	%	

Recommended Operating Conditions

Parameter	Symbol	Min.	Typ.	Max.	Unit	Notes
Ambient Operating Temperature	T_A	0		+60	$^{\circ}\text{C}$	
Case Temperature	T_{CASE}			+75	$^{\circ}\text{C}$	2
Supply Voltage	V_{DDT} V_{DDR}	4.75	5.0	5.25	V	
Supply Current	$I_{TX} + I_{RX}$		200	300	mA	3

Transceiver Electrical Characteristics

($T_A = 0^{\circ}\text{C}$ to $+60^{\circ}\text{C}$, $V_{CC} = 4.75 \text{ V}$ to 5.25 V)

Parameter	Symbol	Min.	Typ.	Max.	Unit	Notes
Surge Current	I_{SURGE}			+30	mA	4
Power Dissipation	P_{DISS}		1.00	1.58	W	5

Notes:

1. Up to applied V_{DDT} .
2. See Figure 1 for measurement point.
3. Maximum current is specified at $V_{CC} = \text{maximum}$ @ maximum operating temperature and end of life.
4. Hot plug above actual steady state current.
5. Total $T_X + R_X$.

AFBR-5601Z

Transmitter Electrical Characteristics

($T_A = 0^\circ\text{C}$ to $+60^\circ\text{C}$, $V_{CC} = 4.75\text{ V}$ to 5.25 V)

Parameter	Symbol	Min.	Typ.	Max.	Unit	Notes
Transmitter Differential Input Voltage	$\pm\text{TX_DAT}$	650		2000	mV p-p	
Transmit Fault Load	$\text{TX_FAULT}_{\text{Load}}$	4.7		10	k Ω	1
TX-DISABLE Assert Time	t_{off}			10	μsec	2
TX_DISABLE Negate Time	T-on			1	msec	3
Time to initialize, includes reset of TX_FAULT	t_{init}			300	msec	4
TX_FAULT from fault to assertion	t_{fault}			7	msec	5
TX_DISABLE time to start reset	t_{reset}	10			μsec	6

Receiver Electrical Characteristics

($T_A = 0^\circ\text{C}$ to $+60^\circ\text{C}$, $V_{CC} = 4.75\text{ V}$ to 5.25 V)

Parameter	Symbol	Min.	Typ.	Max.	Unit	Notes
Receiver Differential Output Voltage	$\pm\text{RX_DAT}$	370		2000	mV p-p	
Receiver Output Rise Time	$t_{\text{RX_DAT}}$		0.25	0.35	ns	7
Receiver Output Fall Time	$t_{\text{RX_DAT}}$		0.25	0.35	ns	7
Receiver Loss of Light Load	$\text{RX_LOS}_{\text{Load}}$	4.7		10	k Ω	1
Receiver Loss of Signal Output Voltage - Low	RX_LOS_L	0.0		0.5	V	
Receiver Loss of Signal Output Voltage - High	RX_LOS_H	V_{CC} -0.5		V_{CC} +0.3	V	
Receiver Loss of Signal Assert Time - Logic low to high	$t_{\text{A,RX_LOS}}$			100	μs	
Receiver Loss of Signal Deassert Time - Logic high to low	$t_{\text{D,RX_LOS}}$			100	μs	

Notes:

1. Pull-up resistor on host V_{CC} .
2. Rising edge of TX_DISABLE to fall of output signal below 10% of nominal.
3. Falling edge of TX_DISABLE to rise of output signal above 90% of nominal.
4. From power on or hot plug after $V_{DDT} > 4.75\text{ V}$ or From negation of TX_DISABLE during reset of TX_FAULT.
5. From occurrence of fault (output safety violation or $V_{DDT} < 4.5\text{ V}$).
6. TX_DISABLE HIGH before TX_DISABLE set LOW.
7. 20 - 80% values.

AFBR-5601Z

Transmitter Optical Characteristics

($T_A = 0^\circ\text{C}$ to $+60^\circ\text{C}$, $V_{CC} = 4.75\text{ V}$ to 5.25 V)

Parameter	Symbol	Min.	Typ.	Max.	Unit	Notes
Output Optical Power 50/125 μm , NA = 0.20 fiber	P_O	-9.5		-4	dBm avg.	
Output Optical Power 62.5/125 μm , NA = 0.275 fiber	P_O	-9.5		-4	dBm avg.	
Optical Extinction Ratio		9			dB	
Center Wavelength	λ_C	830	850	860	nm	
Spectral Width - rms				0.85	nm rms	
Optical Rise/Fall Time	t_r/t_f			0.26	ns	1, 4 and Figure 2
RIN_{12}				-117	dB/Hz	
Total Contributed Jitter	TJ			227	ps _{p-p}	
Coupled Power Ratio	CPR	9			dB	
Max. Pout TX_DISABLE Asserted	P_{OFF}			-35	dBm	

Receiver Optical Characteristics

($T_A = 0^\circ\text{C}$ to $+60^\circ\text{C}$, $V_{CC} = 4.75\text{ V}$ to 5.25 V)

Parameter	Symbol	Min.	Typ.	Max.	Unit	Notes
Input Optical Power	P_{IN}	-17	-22	0	dBm avg.	2
Operating Center Wavelength	λ_C	770		860	nm	
Return Loss		12			dB	
Receiver Loss of Signal - TTL Low	$P_{RX_LOS\ D}$		-23	-17	dBm avg.	
Receiver Loss of Signal - TTL High	$P_{RX_LOS\ A}$	-31	-26		dBm avg.	
Stressed Receiver Sensitivity 62.5 μm fiber				-12.5	dBm	3
50 μm fiber				-13.5	dBm	
Stressed Receiver Eye Opening @TP4		201			ps	3
Electrical 3 dB Upper Cutoff Frequency				1500	MHz	

Notes:

1. 20 - 80 values.
2. Modulated with 2^7-1 PRBS pattern. Results are for a BER of $1E-12$.
3. Tested in accordance with the conformance testing requirements of IEEE802.3z.
4. Laser transmitter pulse response characteristics are specified by an eye diagram (Figure 2).

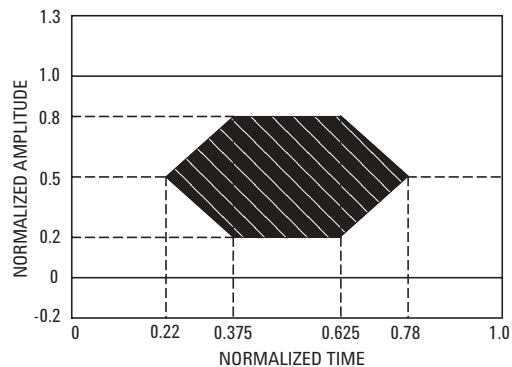

Figure 2. Transmitter Optical Eye Diagram Mask

Long Wavelength GBIC: AFCT-5611Z

Transmitter Section

The transmitter section consists of a 1300 nm MQW Fabry Perot Laser in an optical subassembly (OSA), which mates to the fiber optic cable. The Laser OSA is driven by a custom, silicon bipolar IC which converts differential PECL logic signals (ECL referenced to a +5 V supply) into an analog drive current to the laser.

The laser driver IC incorporates temperature compensation and feedback from the OSA to maintain constant output power and extinction ratio over the operating temperature range.

Receiver Section

The receiver includes a PIN photodiode mounted together with a custom, silicon bipolar transimpedance preamplifier IC, in an OSA. The OSA interfaces to a custom silicon bipolar circuit that provides post-amplification and quantization.

The post-amplifier includes a Signal Detect circuit that provides TTL compatible logic-low output in response to the detection of a usable input optical signal.

Eye Safety Design

The laser driver is designed to be Class 1 eye safe (CDRH21 CFR(J), IEC 60825-1) under a single fault condition.

There are three key elements to the safety circuitry: a monitor diode, a window detector circuit, and direct control of the laser bias. The window detection circuit monitors the average optical power using the photo diode in the laser OSA. If a fault occurs such that the dc bias circuit cannot maintain the preset conditions within $\pm 20\%$, TX_FAULT (Pin 10) will be asserted (high).

Note: Under any single fault, the laser optical output power will remain within Class 1 eye safe limits.

Absolute Maximum Ratings

Stresses in excess of the absolute maximum ratings can cause catastrophic damage to the device. Limits apply to each parameter in isolation, all other parameters having values within the recommended operating conditions. It should not be assumed that limiting values of more than one parameter can be applied to the product at the same time. Exposure to the absolute maximum ratings for extended periods can adversely affect device reliability.

Parameter	Symbol	Min.	Typ.	Max.	Unit	Notes
Storage Temperature	T_S	-40		+85	°C	
Supply Voltage	V_{DDT} V_{DDR}	-0.5		6.0	V	
Data Input Voltage	TX_DAT	-0.5		V_{DDT}	V	
Transmitter Differential Input Voltage	$\pm TX_DAT$			2000	mV p-p	
Relative Humidity	RH	5		95	%	

Recommended Operating Conditions

Parameter	Symbol	Min.	Typ.	Max.	Unit	Notes
Ambient Operating Temperature	T_A	0		+60	°C	
Case Temperature	T_{CASE}			+75	°C	1
Supply Voltage	V_{DDT} V_{DDR}	4.75	5.0	5.25	V	
Supply Current	$I_{TX} + I_{RX}$		200	300	mA	2

Transceiver Electrical Characteristics

($T_A = 0^\circ\text{C}$ to $+60^\circ\text{C}$, $V_{CC} = 4.75\text{ V}$ to 5.25 V)

Parameter	Symbol	Min.	Typ.	Max.	Unit	Notes
Surge Current	I_{SURGE}			+30	mA	3
Power Dissipation	P_{DISS}		1.00	1.58	W	4

Notes:

1. See Figure 1 for measurement point.
2. Maximum current is specified at $V_{CC} = \text{maximum}$ @ maximum operating temperature and end of life.
3. Hot plug above actual steady state current.
4. Total $T_X + R_X$.

AFCT-5611Z

Transmitter Electrical Characteristics

($T_A = 0^\circ\text{C}$ to $+60^\circ\text{C}$, $V_{CC} = 4.75\text{ V}$ to 5.25 V)

Parameter	Symbol	Min.	Typ.	Max.	Unit	Notes
Transmitter Differential Input Voltage	$\pm\text{TX_DAT}$	650		2000	mV p-p	
Transmit Fault Load	$\text{TX_FAULT}_{\text{Load}}$	4.7		10	k Ω	1
Transmit Fault Output - Low	TX_FAULT_L	0.0		0.5	v	
Transmit Fault Output - High	TX_FAULT_H	V_{CC} -0.5		V_{CC} +0.3	v	
TX_DISABLE Assert Time	t_{off}		3	10	μsec	2
TX_DISABLE Negate Time	t_{on}		0.5	1	msec	3
Time to initialize, includes reset of TX_FAULT	t_{init}		30	300	msec	4
TX_FAULT from fault to assertion	t_{fault}		20	100	μsec	5
TX_DISABLE time to start reset	t_{reset}	10			μsec	6

Receiver Electrical Characteristics

($T_A = 0^\circ\text{C}$ to $+60^\circ\text{C}$, $V_{CC} = 4.75\text{ V}$ to 5.25 V)

Parameter	Symbol	Min.	Typ.	Max.	Unit	Notes
Receiver Differential Output Voltage	$\pm\text{RX_DAT}$	370		2000	mV p-p	
Receiver Output Rise Time	$t_{\text{RX_DAT}}$			0.35	ns	7
Receiver Output Fall Time	$t_{\text{FRX_DAT}}$			0.35	ns	7
Receiver Loss of Light Load	$\text{RX_LOS}_{\text{Load}}$	4.7		10	k Ω	1
Receiver Loss of Signal Output Voltage - Low	RX_LOS_L	0.0		0.5	V	
Receiver Loss of Signal Output Voltage - High	RX_LOS_H	V_{CC} -0.5		V_{CC} +0.3	V	
Receiver Loss of Signal Assert Time (off to on)	$t_{\text{A,RX_LOS}}$			100	μs	
Receiver Loss of Signal Deassert Time (on to off)	$t_{\text{D,RX_LOS}}$			100	μs	

Notes:

1. Pull-up resistor on host V_{CC} .
2. Rising edge of TX_DISABLE to fall of output signal below 10% of nominal.
3. Falling edge of TX_DISABLE to rise of output signal above 90% of nominal.
4. From power on or hot plug after $V_{DDT} > 4.75\text{ V}$ or From negation of TX_DISABLE during reset of TX_FAULT.
5. From occurrence of fault (output safety violation or $V_{DDT} < 4.5\text{ V}$).
6. TX_DISABLE HIGH before TX_DISABLE set LOW.
7. 20 - 80% values.

AFCT-5611Z

Transmitter Optical Characteristics

($T_A = 0^\circ\text{C}$ to $+60^\circ\text{C}$, $V_{CC} = 4.75\text{ V}$ to 5.25 V)

Parameter	Symbol	Min.	Typ.	Max.	Unit	Notes
Output Optical Power	P_0					
9/125 μm SMF		-9.5	-7	-3	dBm	
62.5/125 μm MMF		-11.5		-3	dBm	
50/125 μm MMF		-11.5		-3	dBm	
Optical Extinction Ratio		9			dB	
Center Wavelength	λ_c	1285	1310	1343	nm	
Spectral Width - rms				2.8	nm rms	
Optical Rise/Fall Time	t_r/t_f			0.26	ns	1, 4 and Figure 2
RIN_{12}				-116	dB/Hz	
Total Contributed Jitter	TJ			227	ps _{p-p}	
Coupled Power Ratio	CPR	9			dB	
Max. Pout TX_DISABLE Asserted	P_{OFF}			-35	dBm	

Receiver Optical Characteristics

($T_A = 0^\circ\text{C}$ to $+60^\circ\text{C}$, $V_{CC} = 4.75\text{ V}$ to 5.25 V)

Parameter	Symbol	Min.	Typ.	Max.	Unit	Notes
Input Optical Power	P_{IN}	-20	-25	-3	dBm avg.	2
Operating Center Wavelength	λ_c	1270		1355	nm	
Return Loss		12			dB	
Receiver Loss of Signal - TTL Low	$P_{\text{RX_LOS D}}$		-28	-20	dBm avg.	
Receiver Loss of Signal - TTL High	$P_{\text{RX_LOS A}}$	-31			dBm avg.	
Stressed Receiver Sensitivity				-14.4	dBm	3
Stressed Receiver Eye Opening @TP4		201			ps	3
Electrical 3 dB Upper Cutoff Frequency				1500	MHz	

Notes:

1. 20 - 80% values.
2. Modulated with 2^7-1 PRBS pattern. Results are for a BER of $1\text{E}-12$.
3. Tested in accordance with the conformance testing requirements of IEEE802.3z.
4. Laser transmitter pulse response characteristics are specified by an eye diagram (Figure 2).

For product information and a complete list of distributors, please go to our web site: www.avagotech.com

Avago, Avago Technologies, and the A logo are trademarks of Avago Technologies, Pte. in the United States and other countries.
Data subject to change. Copyright © 2006 Avago Technologies Pte. All rights reserved. Obsoletes 5989-3082EN
5989-3792EN - January 12, 2006

