

LM044L

325-429

- 20 character x 4 lines
- Controller LSI HD44780 is built-in (See page 115).
- +5V single power supply

MECHANICAL DATA (Nominal dimensions)

Module size 98W x 60H x 12T (max.) mm
 Effective display area 76.0W x 25.2H mm
 Character size (5 x 7 dots) 2.95W x 4.15H mm
 Character pitch 3.55 mm
 Dot size 0.55W x 0.55H mm
 Weight about 65 g

ABSOLUTE MAXIMUM RATINGS

	min.	max.
Power supply for logic ($V_{DD}-V_{SS}$)	0	6.5 V
Power supply for LCD drive ($V_{DD}-V_O$)	0	6.5 V
Input voltage (V_i)	V_{SS}	V_{DD} V
Operating temperature (T_a)	0	50°C
Storage temperature (T_{stg})	-20	70°C

ELECTRICAL CHARACTERISTICS

$T_a = 25^\circ\text{C}$, $V_{DD} = 5.0 \text{ V} \pm 0.25 \text{ V}$

Input "high" voltage (V_{iH})	2.2 V min.
Input "low" voltage (V_{iL})	0.6 V max.
Output "high" voltage (V_{OH}) ($-I_{OH} = 0.2 \text{ mA}$)	2.4 V min.
Output "low" voltage (V_{OL}) ($I_{OL} = 1.2 \text{ mA}$)	0.4 V max.
Power supply current (I_{DD}) ($V_{DD} = 5.0 \text{ V}$)	1.0 mA typ. 3.5 mA max.
Power supply for LCD drive (Recommended) ($V_{DD}-V_O$)	Duty = 1/15
Range of $V_{DD}-V_O$	1.5~5.25 V
$T_a = 0^\circ\text{C}$	4.6 V typ.
$T_a = 25^\circ\text{C}$	4.4 V typ.
$T_a = 50^\circ\text{C}$	4.2 V typ.

OPTICAL DATA See page 5.

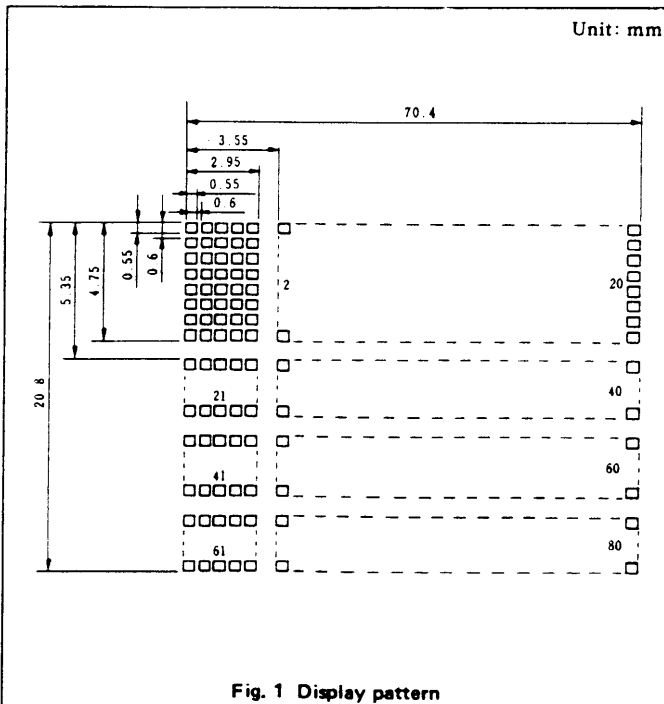

Fig. 1 Display pattern

INTERNAL PIN CONNECTION

Pin No.	Symbol	Level	Function
1	V_{SS}	-	0V
2	V_{DD}	-	+5V
3	V_O	-	-
4	RS	H/L	L: Instruction code input H: Data input
5	R/W	H/L	H: Data read (LCD module → MPU) L: Data write (LCD module ← MPU)
6	E	H, H → L	Enable signal
7	DB0	H/L	Data bus line Note (1), (2)
8	DB1	H/L	
9	DB2	H/L	
10	DB3	H/L	
11	DB4	H/L	
12	DB5	H/L	
13	DB6	H/L	
14	DB7	H/L	

Notes:

In the HD44780, the data can be sent in either 4-bit 2-operation or 8-bit 1-operation so that it can interface to both 4 and 8 bit MPU's.

- (1) When interface data is 4 bits long, data is transferred using only 4 buses of $DB_4 \sim DB_7$, and $DB_0 \sim DB_3$ are not used. Data transfer between the HD44780 and the MPU completes when 4-bit data is transferred twice. Data of the higher order 4 bits (contents of $DB_4 \sim DB_7$, when interface data is 8 bits long) is transferred first and then lower order 4 bits (contents of $DB_0 \sim DB_3$, when interface data is 8 bits long).
- (2) When interface data is 8 bits long, data is transferred using 8 data buses of $DB_0 \sim DB_7$.

DISPLAY POSITION AND DD RAM ADDRESS

Character No.	1	2	3	4	5	6	7	8	9	10	11	12	13	14	15	16	17	18	19	20
1st line	80	81	82	83	84	85	86	87	88	89	8A	8B	8C	8D	8E	8F	90	91	92	93
2nd line	C0	C1	C2	C3	C4	C5	C6	C7	C8	C9	CA	CB	CC	CD	CE	CF	D0	D1	D2	D3
3rd line	94	95	96	97	98	99	9A	9B	9C	9D	9E	9F	A0	A1	A2	A3	A4	A5	A6	A7
4th line	04	05	06	07	08	09	0A	0B	0C	0D	0E	0F	E0	E1	E2	E3	E4	E5	E6	E7

Notes:

- (1) 80 ~ E7 are described in hexadecimal for DD RAM address.
- (2) Function setting of HD44780 should be "N" = "1", "F" = "0" (2 lines of 5 x 7 + cursor).
- (3) DD RAM address is no series in line. Address setting is necessary to change the lines.
- (4) Circuit is equal to 40 characters by 2 lines type.
- (5) In case of executing shift, first line and third line are shifted continuously, also second line and fourth line. Therefore it happens that display of third line is transferred to first line.

Unit: mm

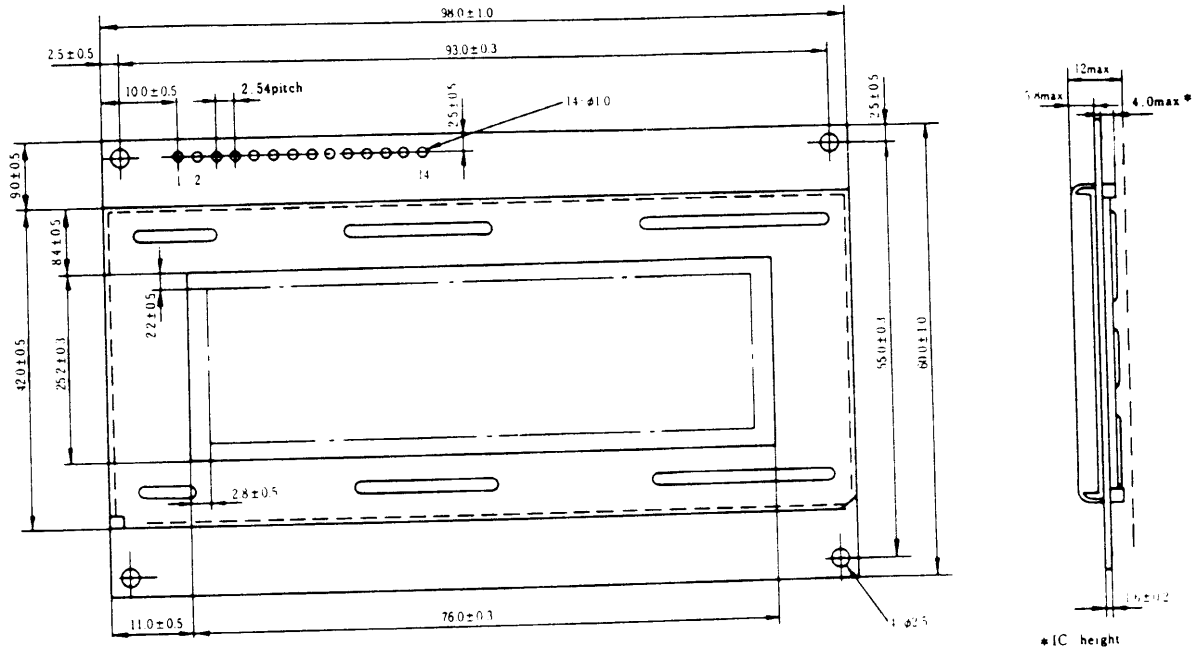

Fig. 2 External dimensions

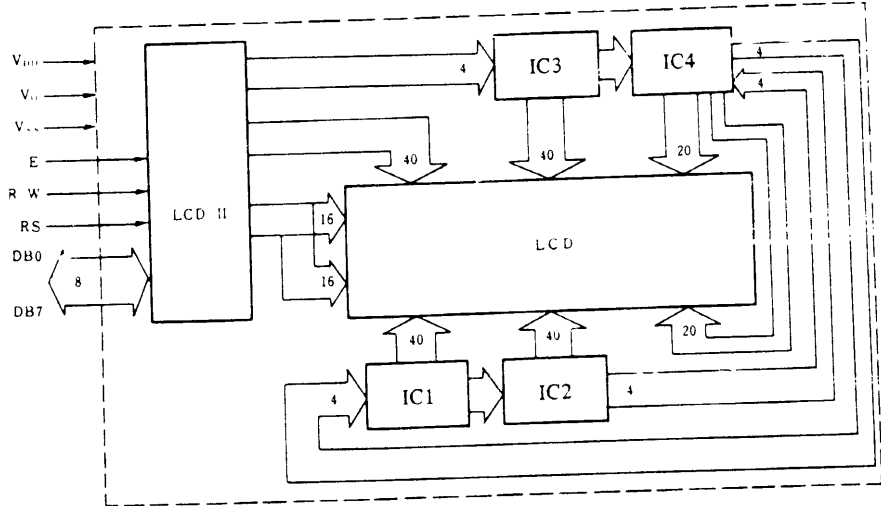

Fig. 3 Block diagram

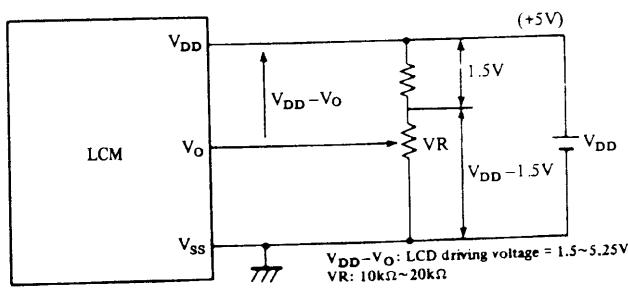

Fig. 4 Power supply

TIMING CHARACTERISTICS

Item	Symbol	Test condition	Min.	Typ.	Max.	Unit
Enable cycle time	t_{cyc}	Fig. 5, Fig. 6	1.0	—	—	μs
Enable pulse width	PW_{EH}	Fig. 5, Fig. 6	450	—	—	ns
Enable rise/fall time	t_{Er}, t_{Ef}	Fig. 5, Fig. 6	—	—	25	ns
RS, R/W set up time	t_{AS}	Fig. 5, Fig. 6	140	—	—	ns
Data delay time	t_{DDR}	Fig. 6	—	—	320	ns
Data set up time	t_{DSW}	Fig. 5	195	—	—	ns
Hold time	t_H	Fig. 5, Fig. 6	20	—	—	ns

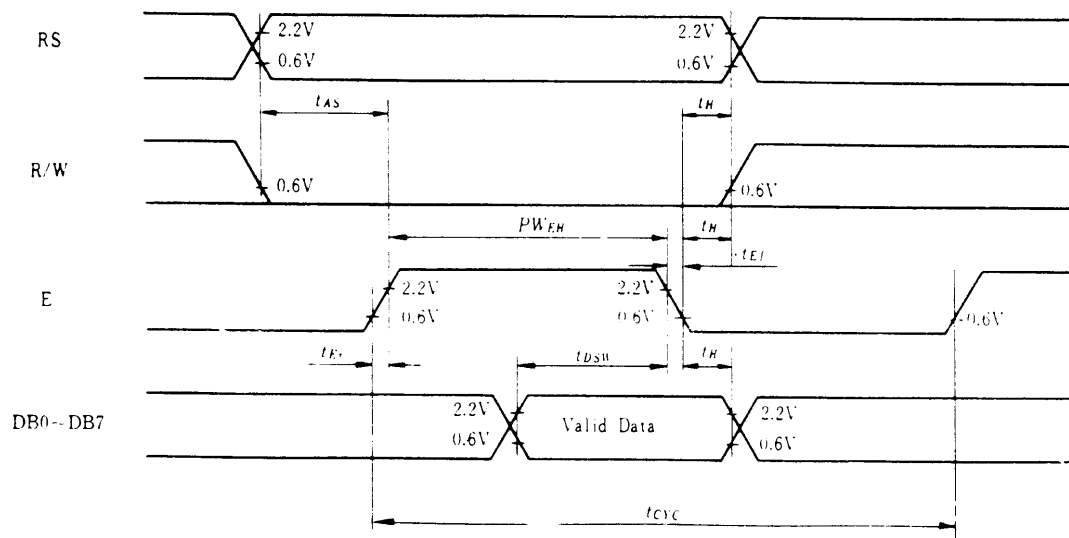

Fig. 5 Interface timing (data write)

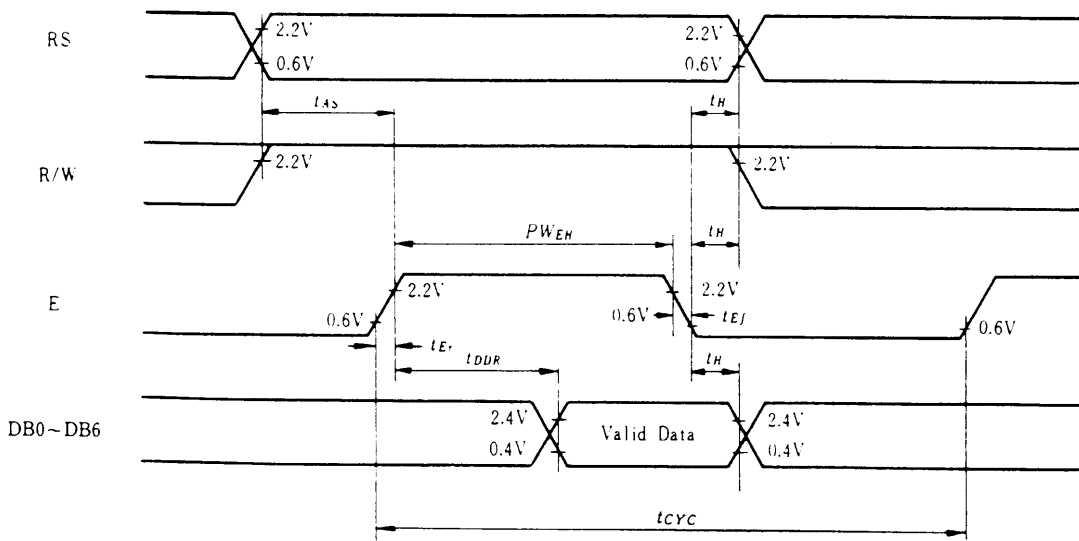

Fig. 6 Interface timing (data read)