

### 2 mode Noise Filters

Type: **EXC24CB/CP**



#### ■ Features

- Improves acoustic quality of mobile phones and portable audio equipment (Burst noise suppression)
- Suppression for both common and normal mode noise
- Small size (L 1.25 mm×W 1.00 mm×H 0.50 mm) and lightweight (About 3 mg)

#### ■ Recommended Applications

- Receiver lines, speaker lines, microphone lines and headset of mobile phones (GSM, TDMA, PDC, PHS).
- Digital audio and video equipment such as PDAs, DSC, DVC, CD Players, DVD Players, MD Players.
- Audio signal lines of PCs.

#### ■ Explanation of Part Numbers

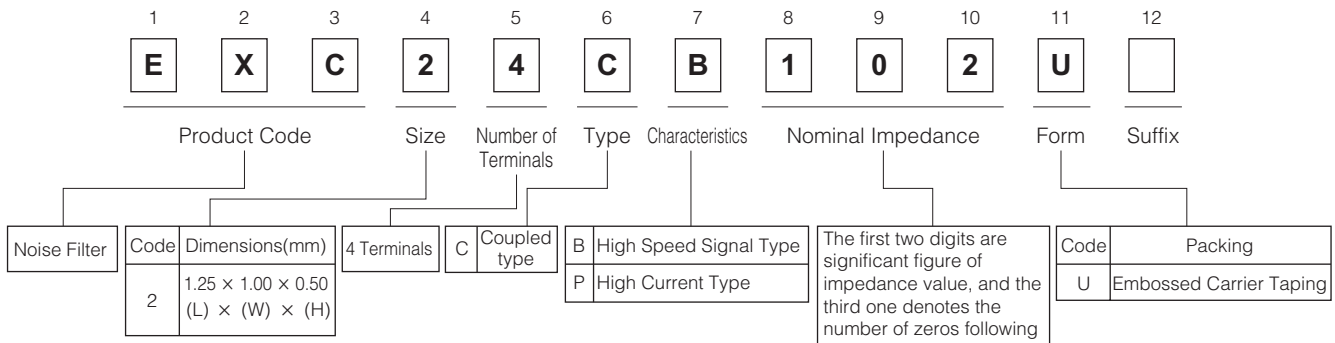

#### ■ Construction

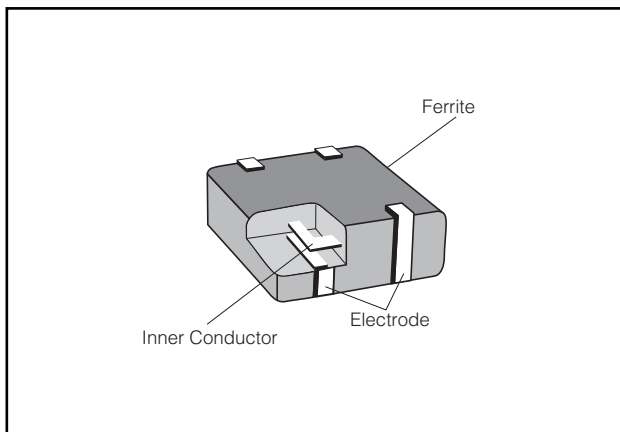

#### ■ Dimensions in mm (not to scale)

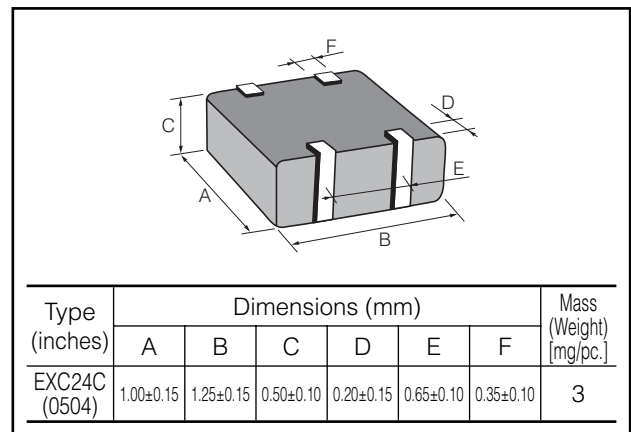

#### ■ Circuit Configuration

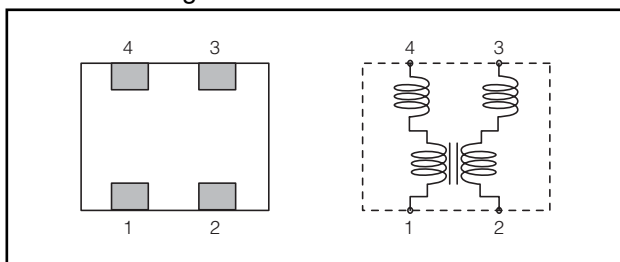

### ■ Ratings

Part Number	Impedance (Open mode)		Rated Voltage (V DC)	Rated Current (mA DC)	DC Resistance ( $\Omega$ ) max.
	( $\Omega$ ) at 100MHz	Tolerance(%)			
EXC24CP121U	120	±25	5	500	0.3
EXC24CP221U	220			350	0.4
EXC24CB221U	220			100	0.7
EXC24CB102U	1000			50	1.5

### ■ Impedance Characteristics (Typical)

Measured by HP4291A

#### ● EXC24CP121U

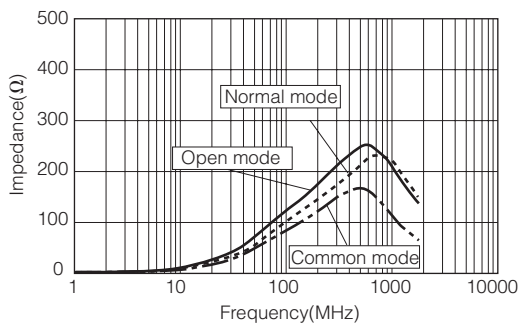

#### ● EXC24CP221U

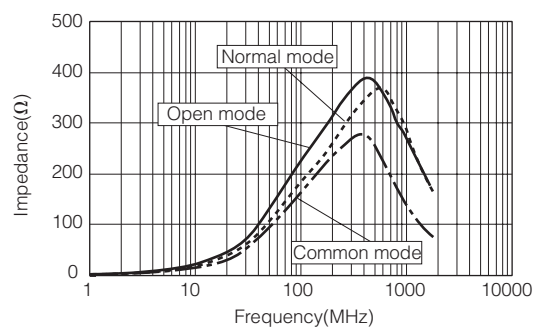

#### ● EXC24CB221U

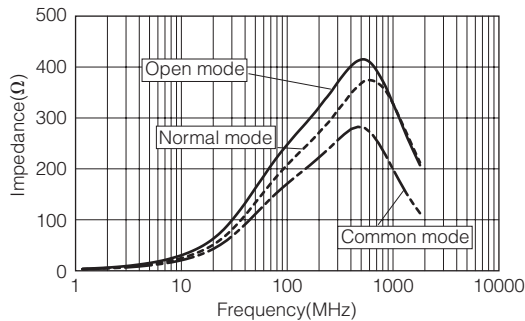

#### ● EXC24CB102U

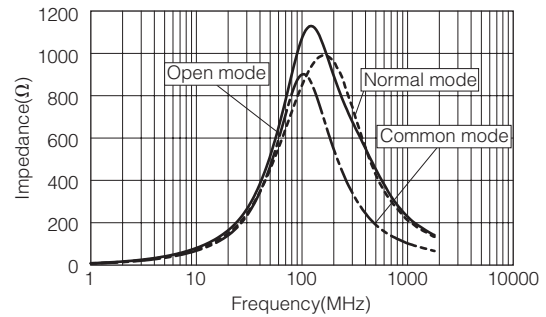

#### ● Measurement Circuit

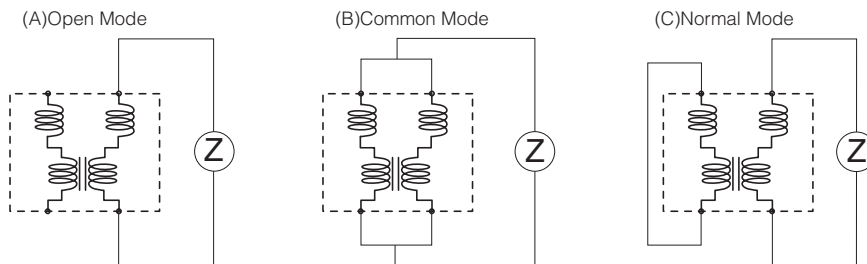

### ■ Packaging Methods (Taping)

#### ● Standard Quantity

Part Number	Kind of Taping	Pitch (P <sub>1</sub> )	Quantity
EXC24C□□□□U	Embossed Carrier Taping	4 mm	5000 pcs./reel

#### ● Embossed Carrier Taping

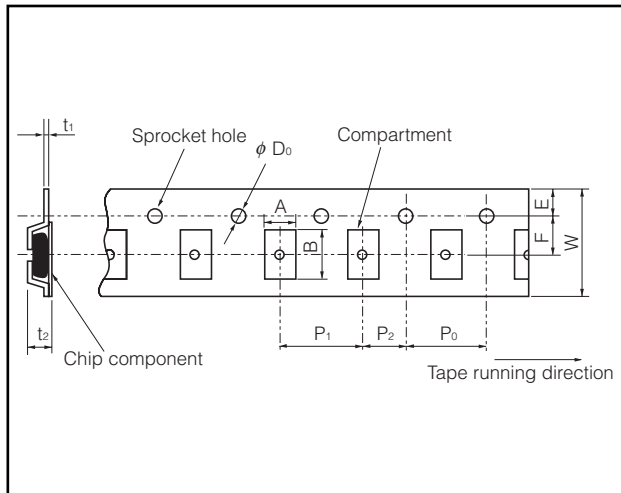

#### ● Taping Reel

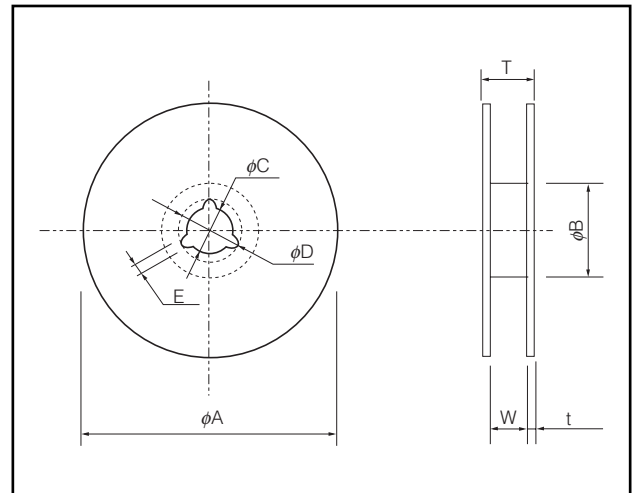

Embossed Carrier Dimensions (mm)

Part Number	A	B	W	F	E	P <sub>1</sub>	P <sub>2</sub>	P <sub>0</sub>	φD <sub>0</sub>	t <sub>1</sub>	t <sub>2</sub>
EXC24C□□□□U	1.20±0.15	1.45±0.15	8.0±0.2	3.5±0.1	1.75±0.10	4.0±0.1	2.0±0.1	4.0±0.1	1.5±0.1	0.25±0.05	0.90±0.15

Standard Reel Dimensions (mm)

Part Number	φA	φB	φC	φD	E	W	T	t
EXC24C□□□□U	180.0±3.0	60.0±1.0	13.0±0.5	21.0±0.8	2.0±0.5	9.0±0.3	11.4±1.5	1.2±0.2

### ■ Recommended Land Pattern Design

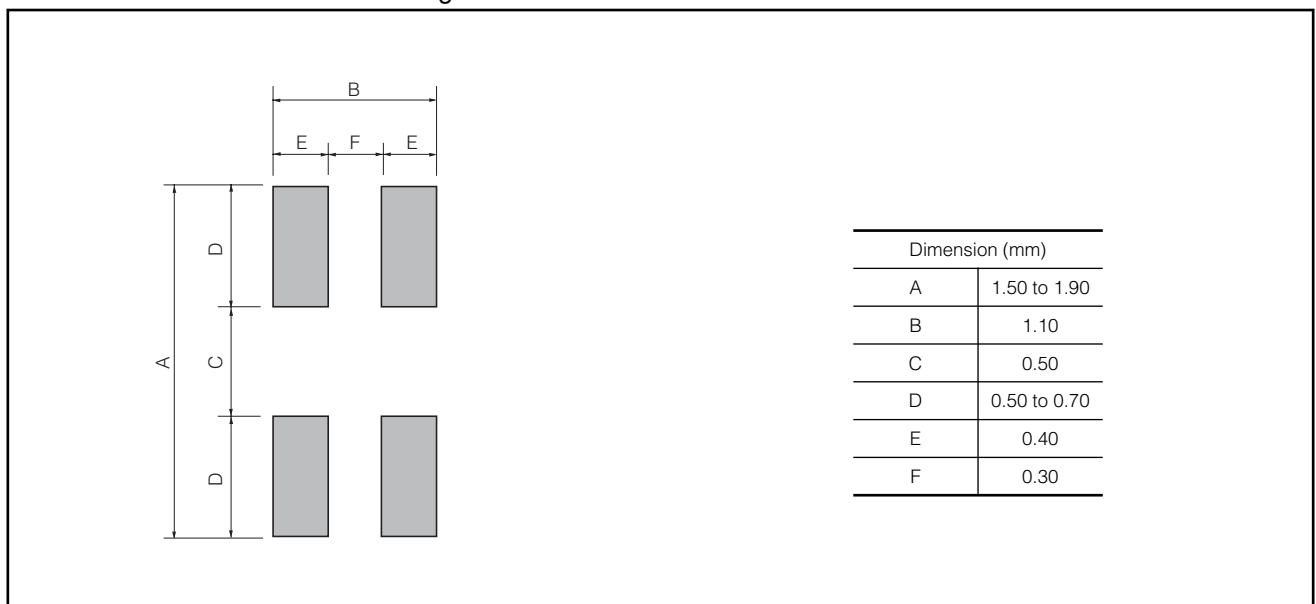

### Recommended Soldering Conditions

Recommendations and precautions are described below.

- Please contact us for additional information when used in conditions other than those specified.
- Please measure the temperature of the terminals and study every kind of solder and printed circuit board for solderability before actual use.

<Recommended reflow soldering temperature>

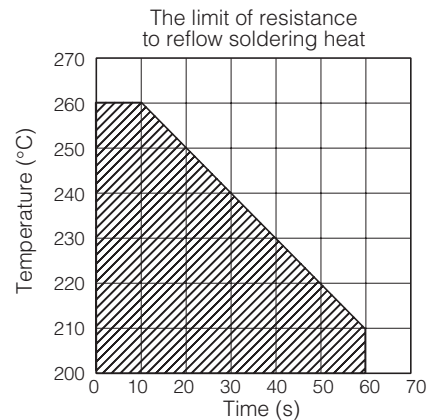
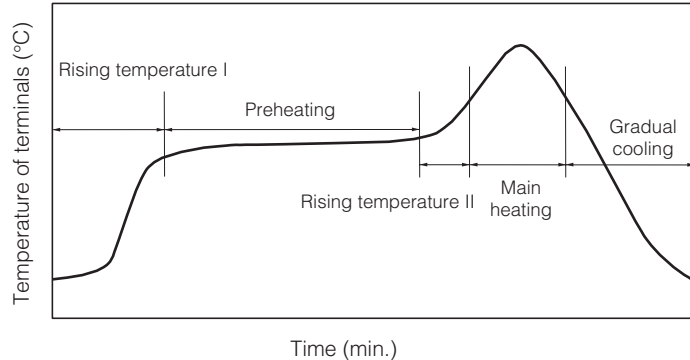

Solder	Rising temperature I	Preheating	Rising temperature II	Main heating	Gradual cooling
For soldering (Sn-37Pb)	The normal time for preheating 30 s to 60 s	140 °C to 160 °C 60 s to 120 s	Preheating to 200 °C 20 s to 40 s	235±10 °C Peak	200 °C to 100 °C 1 °C to 4 °C/s
For lead-free soldering (Sn-3Ag-0.5Cu)	The normal time for preheating 30 s to 60 s	150 °C to 170 °C 60 s to 120 s	Preheating to 210 °C 20 s to 40 s	250 <sup>+10</sup> <sub>-5</sub> °C Peak	210 °C to 100 °C 1 °C to 4 °C/s

\* Reflow soldering shall be performed a maximum of two times.

<Repair with hand soldering>

- Preheat with a blast of hot air or similar method. Use a soldering iron with a tip temperature of 350 °C or less. Solder each electrode for 3 seconds or less.
- Never touch this product with the tip of a soldering iron.

### ⚠ Safety Precautions

The following are precautions for individual products. Please also refer to the precautions common to EMI Filters, Fuses, and Sensors(MR Elements) shown on page EX2 of this catalog.

1. When possible, do not mount 2 mode Noise Filters (hereafter called the filters) by flow soldering. It is highly possible that flow soldering may cause bridges between the electrodes.
2. Use rosin-based flux or halogen-free flux.
3. For cleaning, use an alcohol-based cleaning agent. Before using any other type, consult with our sales person in advance.
4. Do not apply shock to the filters or pinch them with a hard tool (e.g. pliers and tweezers). Otherwise, their bodies may be chipped, affecting their performance. Excessive mechanical stress may damage the filters. Handle with care.
5. Store the filters in a location with a temperature ranging from -5 °C to +40 °C and a relative humidity of 40 % to 60 %, where there are no rapid changes in temperature or humidity.
6. Use the filters within half a year after the date of the outgoing inspection indicated on the packages.

## ⚠ Safety Precautions (Common precautions for EMI Filters, Fuses, and Sensors[MR Elements])

- When using our products, no matter what sort of equipment they might be used for, be sure to make a written agreement on the specifications with us in advance. The design and specifications in this catalog are subject to change without prior notice.
- Do not use the products beyond the specifications described in this catalog.
- This catalog explains the quality and performance of the products as individual components. Before use, check and evaluate their operations when installed in your products.
- Install the following systems for a failsafe design to ensure safety if these products are to be used in equipment where a defect in these products may cause the loss of human life or other significant damage, such as damage to vehicles (automobile, train, vessel), traffic lights, medical equipment, aerospace equipment, electric heating appliances, combustion/gas equipment, rotating equipment, and disaster/crime prevention equipment.
- \* Systems equipped with a protection circuit and a protection device
- \* Systems equipped with a redundant circuit or other system to prevent an unsafe status in the event of a single fault

### (1) Precautions for use

- These products are designed and manufactured for general and standard use in general electronic equipment (e.g. AV equipment, home electric appliances, office equipment, information and communication equipment)
- These products are not intended for use in the following special conditions. Before using the products, carefully check the effects on their quality and performance, and determine whether or not they can be used.
  1. In liquid, such as water, oil, chemicals, or organic solvent
  2. In direct sunlight, outdoors, or in dust
  3. In salty air or air with a high concentration of corrosive gas, such as Cl<sub>2</sub>, H<sub>2</sub>S, NH<sub>3</sub>, SO<sub>2</sub>, or NO<sub>2</sub>
  4. Electric Static Discharge (ESD) Environment  
These components are sensitive to static electricity and can be damaged under static shock (ESD). Please take measures to avoid any of these environments.  
Smaller components are more sensitive to ESD environment.
  5. Electromagnetic Environment  
Avoid any environment where strong electromagnetic waves exist.
  6. In an environment where these products cause dew condensation
  7. Sealing or coating of these products or a printed circuit board on which these products are mounted, with resin or other materials
- These products generate Joule heat when energized. Carefully position these products so that their heat will not affect the other components.
- Carefully position these products so that their temperatures will not exceed the category temperature range due to the effects of neighboring heat-generating components. Do not mount or place heat-generating components or inflammables, such as vinyl-coated wires, near these products (except Thermal Cutoffs).
- Note that non-cleaning solder, halogen-based highly active flux, or water-soluble flux may deteriorate the performance or reliability of the products.
- Carefully select a flux cleaning agent for use after soldering. An unsuitable agent may deteriorate the performance or reliability. In particular, when using water or a water-soluble cleaning agent, be careful not to leave water residues. Otherwise, the insulation performance may be deteriorated.

### (2) Precautions for storage

The performance of these products, including the solderability, is guaranteed for a year from the date of arrival at your company, provided that they remain packed as they were when delivered and stored at a temperature of 5 °C to 35 °C and a relative humidity of 45 % to 85 %. (Micro Chip Fuses: Guaranteed for 6 months from the date of arrival at your company)

The performance of EMI Filters is guaranteed for 6 months or a year from the outgoing inspection date indicated on the packages, provided that they are stored at a temperature of -5 °C to +40 °C and a relative humidity of 40 % to 60 %. Check the guarantee period in the specifications. The performance of Thermal Cutoffs is guaranteed for a year from the outgoing inspection date indicated on the packages, provided that they are stored at a temperature of -10 °C to +40 °C and a relative humidity of 30 % to 75 %.

Even within the above guarantee periods, do not store these products in the following conditions. Otherwise, their electrical performance and/or solderability may be deteriorated, and the packaging materials (e.g. taping materials) may be deformed or deteriorated, resulting in mounting failures.

1. In salty air or in air with a high concentration of corrosive gas, such as Cl<sub>2</sub>, H<sub>2</sub>S, NH<sub>3</sub>, SO<sub>2</sub>, or NO<sub>2</sub>
2. In direct sunlight

### <Package markings>

Package markings include the product number, quantity, and country of origin. In principle, the country of origin should be indicated in English.