

4

3

2

1

THIS DRAWING IS UNPUBLISHED. VERTRAULICHE UNVERÖFFENTLICHTE ZEICHNUNG
 RELEASED FOR PUBLICATION FREI FUER VERÖFFENTLICHUNG
 © COPYRIGHT 1997 BY AMP INCORPORATED. ALL RIGHTS RESERVED. ALLE RECHTE VORBEHALTEN
 MATED WITH: PASSEND ZU: Bg6
 LOC AI DIST -
 REVISIONS AENDERUNGEN
 P LTR
 PROJEKT NR.: A4 PN's 0-7 and 0-8 new ECR-05-000380
 DATE 29.11.2006 DWN SR APVD ST

Variante STS
 Variante STO

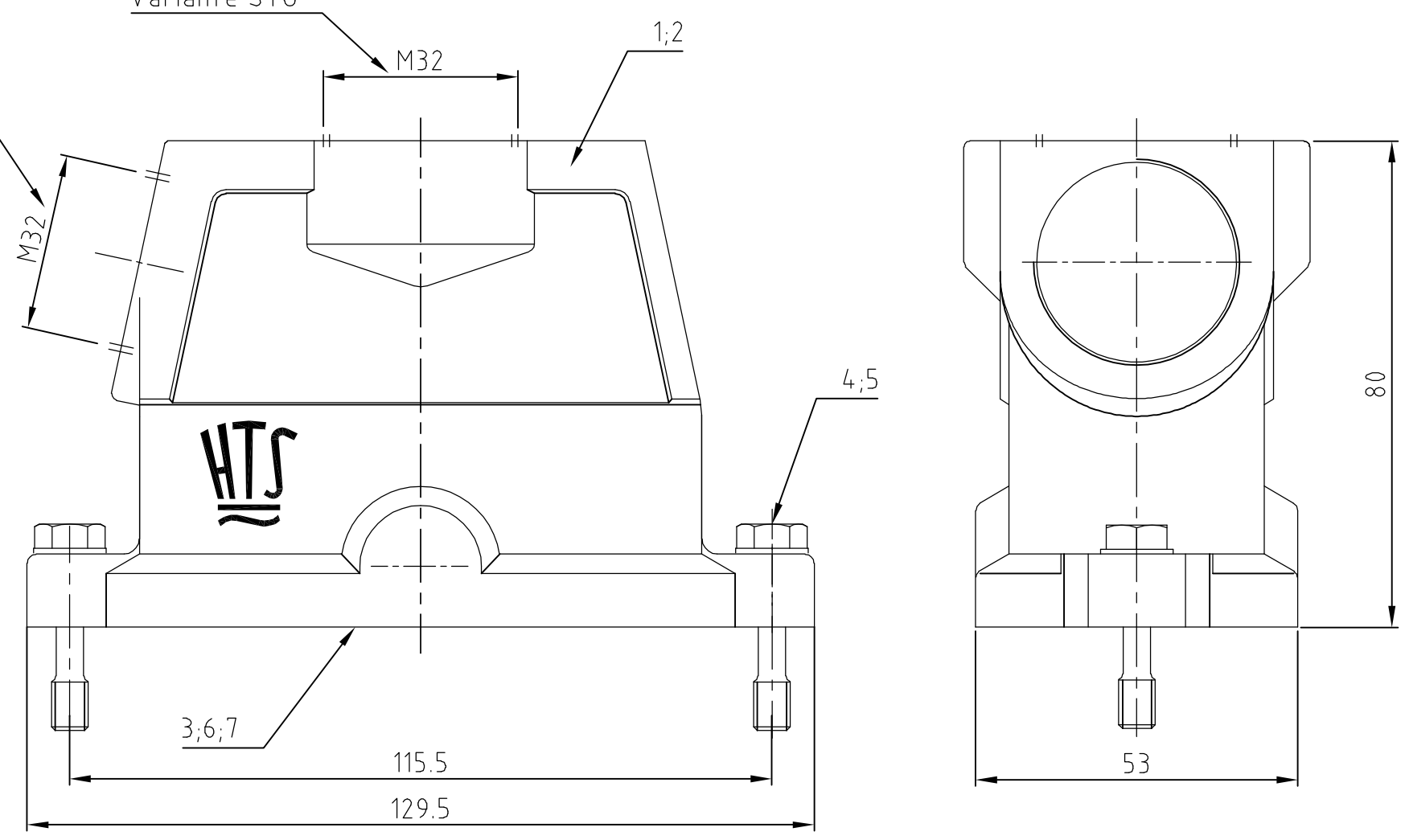

- Notes:
- 1 Material: Housing: aluminium diecasting alloy
 - 2 Surface: chromital TCP passivation + Varnisch black
 - 3 Varnisch on the inside not necessarily
 - 4 Packaging quantity 5 pieces in a carton

1									Hood EMV		grey		7	Side entry
	1								Hood EMV		grey		6	Top entry
2	2	2	2	2	2	2	2	2	Pane	V2A	blank		5	B6.4
2	2	2	2	2	2	2	2	2	Cylinder screw	V2A	blank		4	M6x30
1	1	1	1	1	1	1	1	1	Seal Bg6	Neoprene		black	3	conductiv
		1	1	1		1			Hood EMV-K	aluminium/ALU	SEE NOTE 2	black	2	Top entry
					1			1	Hood EMV	aluminium/ALU		grey	1	Top entry
0-8	0-7	0-6	0-5	0-4	0-2	0-3	0-1		DESCRIPTION / BENENNUNG	MATERIAL	SURFACE / OBERFLÄCHE	COLOR / FARBE	ITEM NO. POS.	REMARKS / BEMERKUNGEN

ORDERING TEXT / BESTELLTEXT	THIS DRAWING IS A CONTROLLED DOCUMENT FOR AMP INCORPORATED. IT IS SUBJECT TO CHANGE AND THE CONTROLLING ENGINEERING ORGANIZATION SHOULD BE CONTACTED FOR THE LATEST REVISION. DIESES ZEICHNUNGSDOKUMENT WIRD DURCH AMP INCORPORATED KONTROLLIERT. AENDERUNGEN, DIE DEM TECHNISCHEN FORTSCHRITT DIENEN, SIND VORBEHALTEN. DEN JEWEILS LETZTQUELTIGEN AENDERUNGSSTAND ERFAHREN SIE AUF ANFRAGE.		DWN Schneider 29.04.2002	HTS Elektrotechnik 53819 Neunkirchen, Germany	
	DIMENSIONS: DIMENSIONEN: mm TOLERANCES UNLESS OTHERWISE SPECIFIED: ALLGEMEINTOLERANZEN 0 PLC # 1 PLC # 2 PLC # 3 PLC # ANGLES / WINKEL #- FINISH / OBERFLAECHE / FARBE		CHK Schweiger 29.04.2002		
			APVD -		NAME HOOD
	MATERIAL		PRODUCT SPEC PRODUKTSPEZ. -		EMV.16/40.1.M32.G
		WEIGHT GEWICHT	APPLICATION SPEC VERARBEITUNGSSPEZ. -	RESTRICTED TO NUR FUER -	
		CUSTOMER DRAWING	SIZE A3 CAGE CODE 00779 DRAWING NO ZEICHNUNGS-NR. C-1106446	MASSSTAB 1:1 BLATT 1 OF VON 1 REV A4	