

THE NEW VALUE FRONTIER

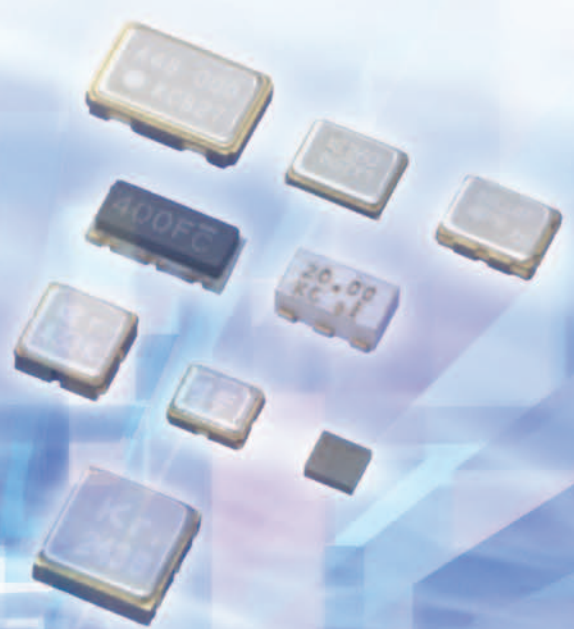

Electronic Components & Devices 2006

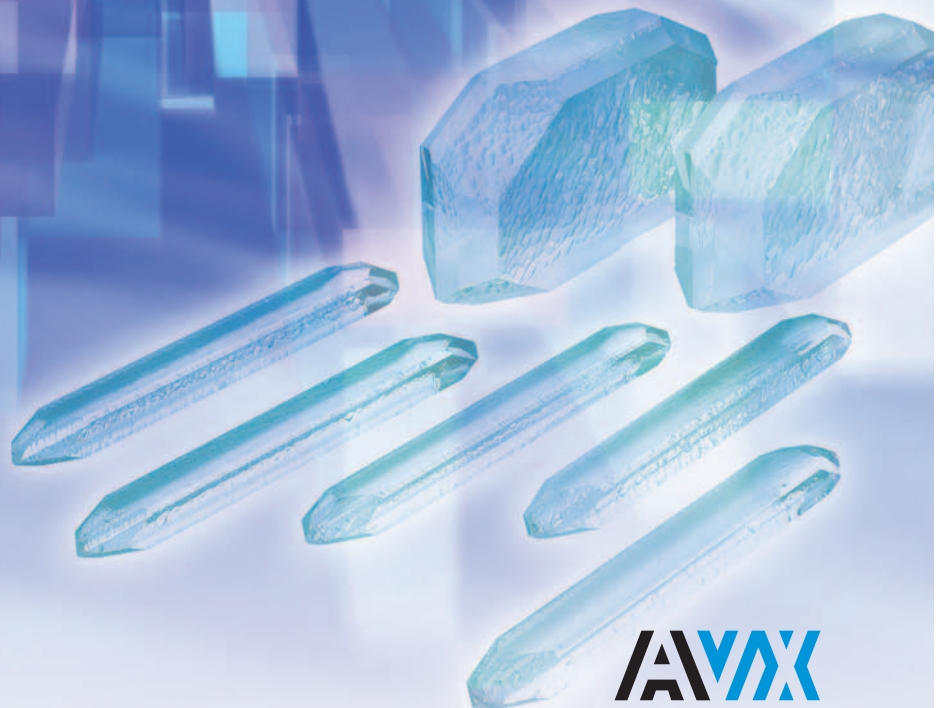
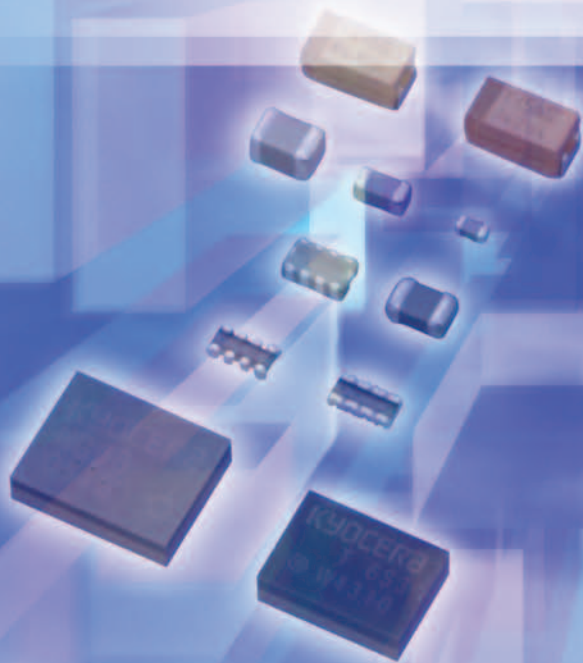

CONTENTS

<table border="0" style="width: 100%; border-collapse: collapse;"> <tr> <td style="background-color: black; color: white; padding: 5px;">1. Capacitors</td> <td style="text-align: right; padding: 5px;">1</td> </tr> <tr> <td style="padding: 5px;">Trimmer Capacitors</td> <td style="text-align: right; padding: 5px;">2</td> </tr> <tr> <td style="background-color: black; color: white; padding: 5px;">2. Resistors</td> <td style="text-align: right; padding: 5px;">5</td> </tr> <tr> <td style="padding: 5px;">Thick Film Chip Resistors</td> <td></td> </tr> <tr> <td style="padding: 5px;"> Chip Resistor Arrays</td> <td style="text-align: right; padding: 5px;">6</td> </tr> <tr> <td style="padding: 5px;"> Chip Resistor Networks</td> <td style="text-align: right; padding: 5px;">8</td> </tr> <tr> <td style="padding: 5px;"> Attenuators</td> <td style="text-align: right; padding: 5px;">9</td> </tr> <tr> <td style="padding: 5px;"> Low Resistance Chip Resistors</td> <td style="text-align: right; padding: 5px;">10</td> </tr> <tr> <td style="padding: 5px;"> Test Conditions and Standards</td> <td style="text-align: right; padding: 5px;">11</td> </tr> <tr> <td style="padding: 5px;"> Packaging/Recommended Land Patterns /Precautions</td> <td style="text-align: right; padding: 5px;">13</td> </tr> <tr> <td style="background-color: black; color: white; padding: 5px;">3. EMC Components</td> <td style="text-align: right; padding: 5px;">16</td> </tr> <tr> <td style="padding: 5px;">EMI Filters</td> <td></td> </tr> <tr> <td style="padding: 5px;"> KNF Series (Signal Lines)</td> <td style="text-align: right; padding: 5px;">17</td> </tr> <tr> <td style="padding: 5px;"> KNA Series (Array type)</td> <td style="text-align: right; padding: 5px;">19</td> </tr> <tr> <td style="padding: 5px;"> KNH Series (Power Lines)</td> <td style="text-align: right; padding: 5px;">21</td> </tr> <tr> <td style="background-color: black; color: white; padding: 5px;">4. Timing Devices</td> <td style="text-align: right; padding: 5px;">22</td> </tr> <tr> <td style="padding: 5px;">Timing Devices Selection Guide</td> <td style="text-align: right; padding: 5px;">23</td> </tr> <tr> <td style="padding: 5px;">Ceramic Resonators</td> <td></td> </tr> <tr> <td style="padding: 5px;"> PRTC Series</td> <td style="text-align: right; padding: 5px;">24</td> </tr> <tr> <td style="padding: 5px;"> SSR Series</td> <td style="text-align: right; padding: 5px;">25</td> </tr> <tr> <td style="padding: 5px;"> PBRC•PRQC/PBRV•PRQV Series</td> <td style="text-align: right; padding: 5px;">26</td> </tr> <tr> <td style="padding: 5px;">SAW Resonators</td> <td style="text-align: right; padding: 5px;">31</td> </tr> <tr> <td style="padding: 5px;">Crystal Units (Consumer Applications)</td> <td></td> </tr> <tr> <td style="padding: 5px;"> CX2520SB (CX-2520SB)</td> <td style="text-align: right; padding: 5px;">34</td> </tr> <tr> <td style="padding: 5px;"> CX3225SB (CX-2520SB)</td> <td style="text-align: right; padding: 5px;">36</td> </tr> <tr> <td style="padding: 5px;"> CX4025SB (CX-4025S)</td> <td style="text-align: right; padding: 5px;">38</td> </tr> <tr> <td style="padding: 5px;"> CX5032SB (CX-96F)</td> <td style="text-align: right; padding: 5px;">39</td> </tr> <tr> <td style="padding: 5px;"> CX5032GB (CX-53F)</td> <td style="text-align: right; padding: 5px;">40</td> </tr> <tr> <td style="padding: 5px;"> CX8045GB (CX-8045G)</td> <td style="text-align: right; padding: 5px;">41</td> </tr> <tr> <td style="padding: 5px;"> CXB855GB (CX-5FD)</td> <td style="text-align: right; padding: 5px;">42</td> </tr> <tr> <td style="padding: 5px;"> CXH49SFB (HC-49/U-S)</td> <td style="text-align: right; padding: 5px;">43</td> </tr> <tr> <td style="padding: 5px;"> CXZ49GFB (CX-49G)</td> <td style="text-align: right; padding: 5px;">44</td> </tr> <tr> <td style="padding: 5px;">Crystal Units (Automotive)</td> <td></td> </tr> <tr> <td style="padding: 5px;"> CX5032GA (CX-53G)</td> <td style="text-align: right; padding: 5px;">45</td> </tr> <tr> <td style="padding: 5px;"> CX8045JA (CX-17F)</td> <td style="text-align: right; padding: 5px;">46</td> </tr> <tr> <td style="padding: 5px;"> CXB855GA (CX-5FW)</td> <td style="text-align: right; padding: 5px;">47</td> </tr> <tr> <td style="padding: 5px;"> CXH49SFA (HC-49/U-S)</td> <td style="text-align: right; padding: 5px;">48</td> </tr> <tr> <td style="padding: 5px;"> CXZ49FFA (CX-49F)</td> <td style="text-align: right; padding: 5px;">49</td> </tr> <tr> <td style="padding: 5px;"> CXZ49LFA (CX-49L)</td> <td style="text-align: right; padding: 5px;">50</td> </tr> <tr> <td style="padding: 5px;">Handling Notes for Crystal Units</td> <td style="text-align: right; padding: 5px;">51</td> </tr> <tr> <td style="padding: 5px;">Characteristics of Crystal Units/ Oscillation Circuits</td> <td style="text-align: right; padding: 5px;">52</td> </tr> <tr> <td style="padding: 5px;">Packaging for Crystal Units</td> <td style="text-align: right; padding: 5px;">60</td> </tr> <tr> <td style="padding: 5px;">Crystal Oscillators (CMOS Output)</td> <td></td> </tr> <tr> <td style="padding: 5px;"> KC2520A-C1 (KC2520)</td> <td style="text-align: right; padding: 5px;">61</td> </tr> <tr> <td style="padding: 5px;"> KC2520A-C2 (KC2520)</td> <td style="text-align: right; padding: 5px;">62</td> </tr> <tr> <td style="padding: 5px;"> KC2520A-C3 (KC2520)</td> <td style="text-align: right; padding: 5px;">63</td> </tr> </table>	1. Capacitors	1	Trimmer Capacitors	2	2. Resistors	5	Thick Film Chip Resistors		Chip Resistor Arrays	6	Chip Resistor Networks	8	Attenuators	9	Low Resistance Chip Resistors	10	Test Conditions and Standards	11	Packaging/Recommended Land Patterns /Precautions	13	3. EMC Components	16	EMI Filters		KNF Series (Signal Lines)	17	KNA Series (Array type)	19	KNH Series (Power Lines)	21	4. Timing Devices	22	Timing Devices Selection Guide	23	Ceramic Resonators		PRTC Series	24	SSR Series	25	PBRC•PRQC/PBRV•PRQV Series	26	SAW Resonators	31	Crystal Units (Consumer Applications)		CX2520SB (CX-2520SB)	34	CX3225SB (CX-2520SB)	36	CX4025SB (CX-4025S)	38	CX5032SB (CX-96F)	39	CX5032GB (CX-53F)	40	CX8045GB (CX-8045G)	41	CXB855GB (CX-5FD)	42	CXH49SFB (HC-49/U-S)	43	CXZ49GFB (CX-49G)	44	Crystal Units (Automotive)		CX5032GA (CX-53G)	45	CX8045JA (CX-17F)	46	CXB855GA (CX-5FW)	47	CXH49SFA (HC-49/U-S)	48	CXZ49FFA (CX-49F)	49	CXZ49LFA (CX-49L)	50	Handling Notes for Crystal Units	51	Characteristics of Crystal Units/ Oscillation Circuits	52	Packaging for Crystal Units	60	Crystal Oscillators (CMOS Output)		KC2520A-C1 (KC2520)	61	KC2520A-C2 (KC2520)	62	KC2520A-C3 (KC2520)	63	<table border="0" style="width: 100%; border-collapse: collapse;"> <tr> <td style="padding: 5px;">KC3225A-C2 (K25-2C)</td> <td style="text-align: right; padding: 5px;">64</td> </tr> <tr> <td style="padding: 5px;">KC3225A-C3 (K25-3C)</td> <td style="text-align: right; padding: 5px;">65</td> </tr> <tr> <td style="padding: 5px;">KC5032C-C1 (K30-1C)</td> <td style="text-align: right; padding: 5px;">66</td> </tr> <tr> <td style="padding: 5px;">KC5032C-C2 (K30-2C)</td> <td style="text-align: right; padding: 5px;">67</td> </tr> <tr> <td style="padding: 5px;">KC5032C-C3 (K30-3C)</td> <td style="text-align: right; padding: 5px;">68</td> </tr> <tr> <td style="padding: 5px;">KC5032C-C3 (K30-3C Heavy Load Type)</td> <td style="text-align: right; padding: 5px;">69</td> </tr> <tr> <td style="padding: 5px;">KC5032C-C5 (K30-HC)</td> <td style="text-align: right; padding: 5px;">70</td> </tr> <tr> <td style="padding: 5px;">KC5032D (FXO-61F2)</td> <td style="text-align: right; padding: 5px;">71</td> </tr> <tr> <td style="padding: 5px;">KC5032D (FXO-64F2)</td> <td style="text-align: right; padding: 5px;">72</td> </tr> <tr> <td style="padding: 5px;">KC5032H (MFO-208F)</td> <td style="text-align: right; padding: 5px;">73</td> </tr> <tr> <td style="padding: 5px;">KC7050A-C1 (K53-1C)</td> <td style="text-align: right; padding: 5px;">74</td> </tr> <tr> <td style="padding: 5px;">KC7050A-C2 (K53-2C)</td> <td style="text-align: right; padding: 5px;">75</td> </tr> <tr> <td style="padding: 5px;">KC7050A-C3 (K53-3C)</td> <td style="text-align: right; padding: 5px;">76</td> </tr> <tr> <td style="padding: 5px;">KC7050A-C5 (K53-HC)</td> <td style="text-align: right; padding: 5px;">77</td> </tr> <tr> <td style="padding: 5px;">KC7050H-C3 (K50H-3C)</td> <td style="text-align: right; padding: 5px;">78</td> </tr> <tr> <td style="padding: 5px;">KC7050S-C1 (FSO-2B)</td> <td style="text-align: right; padding: 5px;">79</td> </tr> <tr> <td style="padding: 5px;">KC7050S-C2 (FSO-2C)</td> <td style="text-align: right; padding: 5px;">80</td> </tr> <tr> <td style="padding: 5px;">KC7050S-C3 (FSO-2D)</td> <td style="text-align: right; padding: 5px;">81</td> </tr> <tr> <td style="padding: 5px;">KC7050B (FXO-31F)</td> <td style="text-align: right; padding: 5px;">82</td> </tr> <tr> <td style="padding: 5px;">KC7050B (FXO-37F,N)</td> <td style="text-align: right; padding: 5px;">83</td> </tr> <tr> <td style="padding: 5px;">KC7050B (FXO-34F)</td> <td style="text-align: right; padding: 5px;">84</td> </tr> <tr> <td style="padding: 5px;">KC7050C-C3 (K50-3C)</td> <td style="text-align: right; padding: 5px;">85</td> </tr> <tr> <td style="padding: 5px;">KC7050C-C5 (K50-HC)</td> <td style="text-align: right; padding: 5px;">86</td> </tr> <tr> <td style="padding: 5px;">KCJXO (JXO)</td> <td style="text-align: right; padding: 5px;">87</td> </tr> <tr> <td style="padding: 5px;">KCEX03 (EXO-3)</td> <td style="text-align: right; padding: 5px;">88</td> </tr> <tr> <td style="padding: 5px;">Crystal Oscillators (LV-PECL Output)</td> <td></td> </tr> <tr> <td style="padding: 5px;"> KC5032P-P2</td> <td style="text-align: right; padding: 5px;">89</td> </tr> <tr> <td style="padding: 5px;"> KC5032P-P3</td> <td style="text-align: right; padding: 5px;">90</td> </tr> <tr> <td style="padding: 5px;"> KC7050P-P2</td> <td style="text-align: right; padding: 5px;">91</td> </tr> <tr> <td style="padding: 5px;"> KC7050P-P3</td> <td style="text-align: right; padding: 5px;">92</td> </tr> <tr> <td style="padding: 5px;"> KC7050S-P2 (FSO-1C)</td> <td style="text-align: right; padding: 5px;">93</td> </tr> <tr> <td style="padding: 5px;"> KC7050S-P3 (FSO-1D)</td> <td style="text-align: right; padding: 5px;">94</td> </tr> <tr> <td style="padding: 5px;">Crystal Oscillators (LVDS Output)</td> <td></td> </tr> <tr> <td style="padding: 5px;"> KC5032P-L2</td> <td style="text-align: right; padding: 5px;">95</td> </tr> <tr> <td style="padding: 5px;"> KC5032P-L3</td> <td style="text-align: right; padding: 5px;">96</td> </tr> <tr> <td style="padding: 5px;"> KC7050P-L2</td> <td style="text-align: right; padding: 5px;">97</td> </tr> <tr> <td style="padding: 5px;"> KC7050P-L3</td> <td style="text-align: right; padding: 5px;">98</td> </tr> <tr> <td style="padding: 5px;">Voltage Controlled Oscillators</td> <td></td> </tr> <tr> <td style="padding: 5px;"> KV5032A (VC-FXO-65F)</td> <td style="text-align: right; padding: 5px;">99</td> </tr> <tr> <td style="padding: 5px;"> KV7050A (VC-FXO-35F)</td> <td style="text-align: right; padding: 5px;">100</td> </tr> <tr> <td style="padding: 5px;"> KV7050L-C (VCXO-7050/7050L)</td> <td style="text-align: right; padding: 5px;">101</td> </tr> <tr> <td style="padding: 5px;"> KV7050W-P3 (K50V-3P)</td> <td style="text-align: right; padding: 5px;">102</td> </tr> <tr> <td style="padding: 5px;"> KV7050S-P3 (VC-FSO-1D)</td> <td style="text-align: right; padding: 5px;">103</td> </tr> <tr> <td style="padding: 5px;">Temperature Compensated Crystal Oscillators (TCXO)</td> <td></td> </tr> <tr> <td style="padding: 5px;"> KT2520Y</td> <td style="text-align: right; padding: 5px;">104</td> </tr> <tr> <td style="padding: 5px;"> KT3225 (KT21) for GPS</td> <td style="text-align: right; padding: 5px;">105</td> </tr> <tr> <td style="padding: 5px;"> KT3225 (KT21)</td> <td style="text-align: right; padding: 5px;">106</td> </tr> <tr> <td style="padding: 5px;"> KT5032 (KT18B, (VC)-TCXO-208Cx)</td> <td style="text-align: right; padding: 5px;">107</td> </tr> </table>	KC3225A-C2 (K25-2C)	64	KC3225A-C3 (K25-3C)	65	KC5032C-C1 (K30-1C)	66	KC5032C-C2 (K30-2C)	67	KC5032C-C3 (K30-3C)	68	KC5032C-C3 (K30-3C Heavy Load Type)	69	KC5032C-C5 (K30-HC)	70	KC5032D (FXO-61F2)	71	KC5032D (FXO-64F2)	72	KC5032H (MFO-208F)	73	KC7050A-C1 (K53-1C)	74	KC7050A-C2 (K53-2C)	75	KC7050A-C3 (K53-3C)	76	KC7050A-C5 (K53-HC)	77	KC7050H-C3 (K50H-3C)	78	KC7050S-C1 (FSO-2B)	79	KC7050S-C2 (FSO-2C)	80	KC7050S-C3 (FSO-2D)	81	KC7050B (FXO-31F)	82	KC7050B (FXO-37F,N)	83	KC7050B (FXO-34F)	84	KC7050C-C3 (K50-3C)	85	KC7050C-C5 (K50-HC)	86	KCJXO (JXO)	87	KCEX03 (EXO-3)	88	Crystal Oscillators (LV-PECL Output)		KC5032P-P2	89	KC5032P-P3	90	KC7050P-P2	91	KC7050P-P3	92	KC7050S-P2 (FSO-1C)	93	KC7050S-P3 (FSO-1D)	94	Crystal Oscillators (LVDS Output)		KC5032P-L2	95	KC5032P-L3	96	KC7050P-L2	97	KC7050P-L3	98	Voltage Controlled Oscillators		KV5032A (VC-FXO-65F)	99	KV7050A (VC-FXO-35F)	100	KV7050L-C (VCXO-7050/7050L)	101	KV7050W-P3 (K50V-3P)	102	KV7050S-P3 (VC-FSO-1D)	103	Temperature Compensated Crystal Oscillators (TCXO)		KT2520Y	104	KT3225 (KT21) for GPS	105	KT3225 (KT21)	106	KT5032 (KT18B, (VC)-TCXO-208Cx)	107
1. Capacitors	1																																																																																																																																																																																												
Trimmer Capacitors	2																																																																																																																																																																																												
2. Resistors	5																																																																																																																																																																																												
Thick Film Chip Resistors																																																																																																																																																																																													
Chip Resistor Arrays	6																																																																																																																																																																																												
Chip Resistor Networks	8																																																																																																																																																																																												
Attenuators	9																																																																																																																																																																																												
Low Resistance Chip Resistors	10																																																																																																																																																																																												
Test Conditions and Standards	11																																																																																																																																																																																												
Packaging/Recommended Land Patterns /Precautions	13																																																																																																																																																																																												
3. EMC Components	16																																																																																																																																																																																												
EMI Filters																																																																																																																																																																																													
KNF Series (Signal Lines)	17																																																																																																																																																																																												
KNA Series (Array type)	19																																																																																																																																																																																												
KNH Series (Power Lines)	21																																																																																																																																																																																												
4. Timing Devices	22																																																																																																																																																																																												
Timing Devices Selection Guide	23																																																																																																																																																																																												
Ceramic Resonators																																																																																																																																																																																													
PRTC Series	24																																																																																																																																																																																												
SSR Series	25																																																																																																																																																																																												
PBRC•PRQC/PBRV•PRQV Series	26																																																																																																																																																																																												
SAW Resonators	31																																																																																																																																																																																												
Crystal Units (Consumer Applications)																																																																																																																																																																																													
CX2520SB (CX-2520SB)	34																																																																																																																																																																																												
CX3225SB (CX-2520SB)	36																																																																																																																																																																																												
CX4025SB (CX-4025S)	38																																																																																																																																																																																												
CX5032SB (CX-96F)	39																																																																																																																																																																																												
CX5032GB (CX-53F)	40																																																																																																																																																																																												
CX8045GB (CX-8045G)	41																																																																																																																																																																																												
CXB855GB (CX-5FD)	42																																																																																																																																																																																												
CXH49SFB (HC-49/U-S)	43																																																																																																																																																																																												
CXZ49GFB (CX-49G)	44																																																																																																																																																																																												
Crystal Units (Automotive)																																																																																																																																																																																													
CX5032GA (CX-53G)	45																																																																																																																																																																																												
CX8045JA (CX-17F)	46																																																																																																																																																																																												
CXB855GA (CX-5FW)	47																																																																																																																																																																																												
CXH49SFA (HC-49/U-S)	48																																																																																																																																																																																												
CXZ49FFA (CX-49F)	49																																																																																																																																																																																												
CXZ49LFA (CX-49L)	50																																																																																																																																																																																												
Handling Notes for Crystal Units	51																																																																																																																																																																																												
Characteristics of Crystal Units/ Oscillation Circuits	52																																																																																																																																																																																												
Packaging for Crystal Units	60																																																																																																																																																																																												
Crystal Oscillators (CMOS Output)																																																																																																																																																																																													
KC2520A-C1 (KC2520)	61																																																																																																																																																																																												
KC2520A-C2 (KC2520)	62																																																																																																																																																																																												
KC2520A-C3 (KC2520)	63																																																																																																																																																																																												
KC3225A-C2 (K25-2C)	64																																																																																																																																																																																												
KC3225A-C3 (K25-3C)	65																																																																																																																																																																																												
KC5032C-C1 (K30-1C)	66																																																																																																																																																																																												
KC5032C-C2 (K30-2C)	67																																																																																																																																																																																												
KC5032C-C3 (K30-3C)	68																																																																																																																																																																																												
KC5032C-C3 (K30-3C Heavy Load Type)	69																																																																																																																																																																																												
KC5032C-C5 (K30-HC)	70																																																																																																																																																																																												
KC5032D (FXO-61F2)	71																																																																																																																																																																																												
KC5032D (FXO-64F2)	72																																																																																																																																																																																												
KC5032H (MFO-208F)	73																																																																																																																																																																																												
KC7050A-C1 (K53-1C)	74																																																																																																																																																																																												
KC7050A-C2 (K53-2C)	75																																																																																																																																																																																												
KC7050A-C3 (K53-3C)	76																																																																																																																																																																																												
KC7050A-C5 (K53-HC)	77																																																																																																																																																																																												
KC7050H-C3 (K50H-3C)	78																																																																																																																																																																																												
KC7050S-C1 (FSO-2B)	79																																																																																																																																																																																												
KC7050S-C2 (FSO-2C)	80																																																																																																																																																																																												
KC7050S-C3 (FSO-2D)	81																																																																																																																																																																																												
KC7050B (FXO-31F)	82																																																																																																																																																																																												
KC7050B (FXO-37F,N)	83																																																																																																																																																																																												
KC7050B (FXO-34F)	84																																																																																																																																																																																												
KC7050C-C3 (K50-3C)	85																																																																																																																																																																																												
KC7050C-C5 (K50-HC)	86																																																																																																																																																																																												
KCJXO (JXO)	87																																																																																																																																																																																												
KCEX03 (EXO-3)	88																																																																																																																																																																																												
Crystal Oscillators (LV-PECL Output)																																																																																																																																																																																													
KC5032P-P2	89																																																																																																																																																																																												
KC5032P-P3	90																																																																																																																																																																																												
KC7050P-P2	91																																																																																																																																																																																												
KC7050P-P3	92																																																																																																																																																																																												
KC7050S-P2 (FSO-1C)	93																																																																																																																																																																																												
KC7050S-P3 (FSO-1D)	94																																																																																																																																																																																												
Crystal Oscillators (LVDS Output)																																																																																																																																																																																													
KC5032P-L2	95																																																																																																																																																																																												
KC5032P-L3	96																																																																																																																																																																																												
KC7050P-L2	97																																																																																																																																																																																												
KC7050P-L3	98																																																																																																																																																																																												
Voltage Controlled Oscillators																																																																																																																																																																																													
KV5032A (VC-FXO-65F)	99																																																																																																																																																																																												
KV7050A (VC-FXO-35F)	100																																																																																																																																																																																												
KV7050L-C (VCXO-7050/7050L)	101																																																																																																																																																																																												
KV7050W-P3 (K50V-3P)	102																																																																																																																																																																																												
KV7050S-P3 (VC-FSO-1D)	103																																																																																																																																																																																												
Temperature Compensated Crystal Oscillators (TCXO)																																																																																																																																																																																													
KT2520Y	104																																																																																																																																																																																												
KT3225 (KT21) for GPS	105																																																																																																																																																																																												
KT3225 (KT21)	106																																																																																																																																																																																												
KT5032 (KT18B, (VC)-TCXO-208Cx)	107																																																																																																																																																																																												

CONTENTS

High Precision Oscillators	108
(VC-) DTCXO-12A	108
(VC-) DTCXO-13A	109
DTCXO-15A	110
OCVCXO-120A	111
MCXO-094B	112
Handling Notes for Crystal Oscillators	113
Packaging for Crystal Oscillators	116

5. Crystal Applied Products 117

Synthetic Quartz Crystals	118
Crystal Blanks	121
Optical Devices	
Crystal Optical Low Pass Filters	122
IR-cut Filters	123
Phase Plates	124
Phase Plates for LCD Projectors	125
Quartz Crystal Plates for LCD Projectors	126

6. Filters 127

SAW Filters	
SF Series	128
SF3030B190M00B04MA00 (W-CDMA)	132
SF3838B190M00B04MA00 (W-CDMA)	132
SF5032B190M00B03MA02 (W-CDMA)	133
SF5032B380M00B03MA00 (W-CDMA)	133
SF6035B183M60C01MA00 (CDMA)	134
SF7050C110M00C01MA00 (cdmaOne)	135
SF9148B085M38C01MA00 (cdmaOne)	136
SF7050B204M00C600A00 (SCDMA)	137
SF7050C083M16C026A00 (AMPS)	138
SF7050C085M38C026A01 (AMPS)	138
SF7050C183M60C022B00 (AMPS)	139
SF3838B315M00C300A00 (RKE)	140
SF3838B315M00B200A00 (RKE)	140
SF3838B433M92C300A00 (RKE)	141
SF3838B433M92B200A00 (RKE)	141
PAFC433.92 (RKE)	142
SF5050B868M30C600A00 (RKE)	143
SF3030B428M00T04MA02 (Radio Communications)	144
SF3535B426M54B800A00 (Radio Communications)	145
SF3838B426M07C080A00 (Radio Communications)	145
SF3535B429M55B800A00 (Radio Communications)	145
SF3838B429M17C080A00 (Radio Communications)	145
SF3838B440M20B400A00 (Radio Communications)	145

SF7050B469M18B01MA00 (Radio Communications)	145
PAFA (PHS)	146
SF3535B243M95B220A00 (PHS)	147
SF3838B243M95B220A00 (PHS)	148
SF3838B248M45B220A00 (PHS)	148
PAFC243B (PHS)	149
SF9148B155M52C155A00 (Fiber Optics)	151
SF9148B622M08C622A00 (Fiber Optics)	151
Monolithic Crystal Filters (MCF)	
FP2	152
FP4	153
49/U	154
Characteristic Diagram and Terms of MCF	155
Packaging for Filters	156

7. RF Modules 157

Antenna Switch Modules	158
Bluetooth™ Modules	163

8. Others 166

Shock Sensors	167
Piezo Ceramic Elements	168
Piezo Buzzers	170
Manufacturing Plants	171
Kyocera Network in Japan	172
Sales Offices	173
Notes for Using the Catalog	175

THE NEW VALUE FRONTIER



Capacitors

Trimmer Capacitors





Features

- SMD small & thin package
- Wide capacitance range
- Washable and non-washable types available
- Plus slot(+) suitable for auto-adjustment

Applications

- AV Equipment
- Cellular Phone
- Cordless Phone
- TCXO
- Keyless Entry

How to Order

CTZ3 S - 05 A - W 1 - P F
① ② ③ ④ ⑤ ⑥ ⑦ ⑧

① Series

CTZ3	CTZ3 Series
CTZ2	CTZ2 Series

② Type

S	Reflow non washable type
E	Reflow washable type

③ Maximum Capacitance

03	3pF	30	30pF
05	5pF	40	40pF
10	10pF	50	50pF
20	20pF		

④ Temperature Coefficient (ppm/°C)

A	NPO±500	C	N750±500
B	N400±500		

⑤ Packaging

W	W Direction Taping
X	X Direction Taping
B	Bulk

⑥ Taping Quantity (Unit : pcs)

1	1,000	CTZ3 Series
2	2,000	CTZ2 Series

⑦ Pin Head Type

P	Plus Slot
----------	-----------

⑧ Lead Specification

F	Lead Forming Type (CTZ3 type)
----------	-------------------------------

* ⑧ is denoted by space for CTZ2 series.

Specifications

Part No.	Capacitance(pF)		Q 1±0.1 (MHz)	Temperature Coefficient (ppm/°C)	
	Cmax.	Cmin.			
CTZ2 S/E	03A	3 ^{+100%} / _{-0%}	2.0max.	≥150	NPO±500
	05A	5 ^{+100%} / _{-0%}	3.0max.	≥150	NPO±500
	10A	10 ^{+100%} / _{-0%}	3.0max.	≥150	NPO±500
	20C	20 ^{+100%} / _{-0%}	5.5max.	≥150	N750±500
CTZ3 S/E	03A	3 ^{+100%} / _{-0%}	1.0max.	≥300	NPO±500
	05A	5 ^{+100%} / _{-0%}	1.5max.	≥300	NPO±500
	10A	10 ^{+100%} / _{-0%}	2.5max.	≥300	NPO±500
	10B	10 ^{+100%} / _{-0%}	1.5max.	≥300	N400±500
	20C	20 ^{+100%} / _{-0%}	4.5max.	≥300	N750±500
	30C	30 ^{+100%} / _{-0%}	4.5max.	≥300	N750±500
	40C	40 ^{+100%} / _{-0%}	4.5max.	≥300	N750±500
	50C	50 ^{+100%} / _{-0%}	4.5max.	≥200	N750±500

Series	Rated Voltage (V•DC)	Temperature Range (°C)	Insulation Resistance (MΩ)	Torque (g•cm)
CTZ2S/E	25	-40 to +85	≥10 ⁴	10 to 150
CTZ3S/E	25	-40 to +85	≥10 ⁴	10 to 150

Series	Dimensions (Unit : mm)	Recommended Land Pattern (Unit: mm)
CTZ2 Series		
CTZ3 Series		

Frequency Characteristics

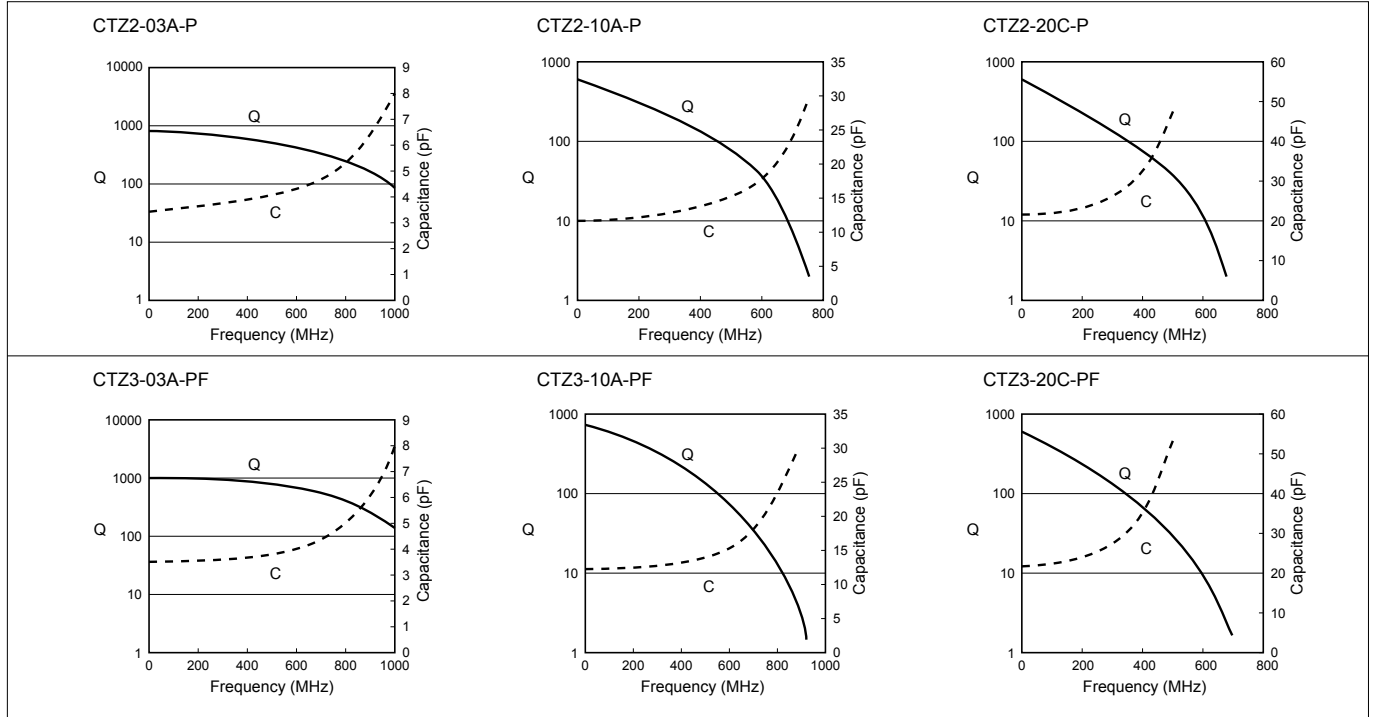

Tape & Reel

• Reel

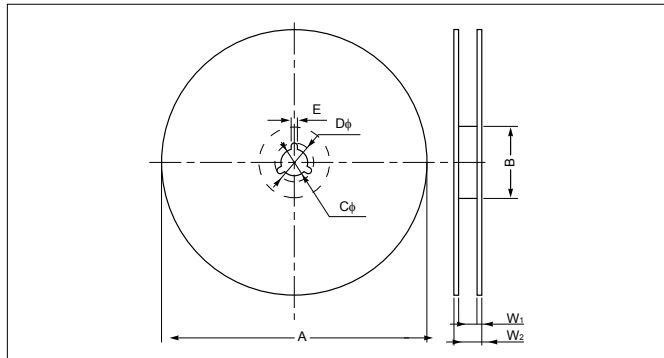

• Carrier Tape

(Unit : mm)

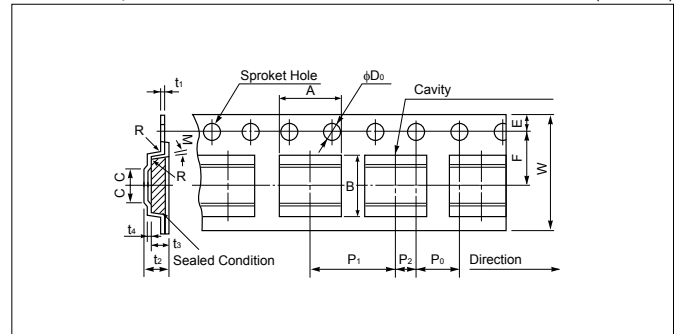

• Tape Loading

W Direction — Standard
X Direction — Option

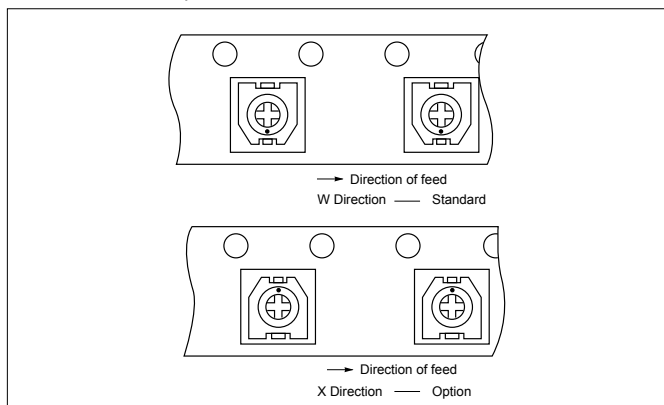

	CTZ2 Series	CTZ3 Series
A	2.7±0.1	3.35±0.1
B	3.2±0.1	4.6 ^{+0.2} _{-0.0}
W	12.0±0.3	12.0±0.3
F	5.5±0.05	5.5±0.05
E	1.75±0.1	1.75±0.1
P0	4.0±0.1	4.0±0.1
P1	4.0±0.1	8.0±0.1
P2	2.0±0.05	2.0±0.05
φD0	1.5 ^{+0.1} _{-0.0}	1.5 ^{+0.1} _{-0.0}
t1	0.3±0.1	0.3±0.1
t2	1.9±0.1	2.5±0.1
t3	1.3 ^{+0.15} _{-0.0}	2.0±0.1
t4	0.3±0.1	0.3±0.05
C	2.06±0.1	2.7±0.1

(Unit : mm)

	A	B	C	D	E	W ₁	W ₂
CTZ2 Series (2,000pcs.)	180 ^{+0.0} _{-3.0}	60.0 ^{+1.0} _{-0.0}	13.0±0.2	21.0±0.8	2.0±0.5	13.0±0.3	15.4±1.0
CTZ3 Series (1,000pcs.)							

PCB Mounting

- When our recommended landpattern is not used, please check mounting alignment.
- When mounting on PCB, please do not apply pressure to trimmer capacitors over 500g.f.

Soldering

- When using soldering iron, adjust iron tip to 280°C. max.
- Please find below recommended solder profile.

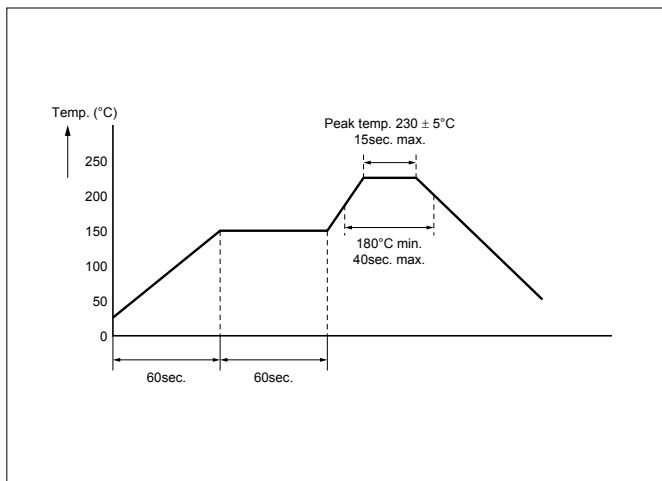

Storage Conditions

- 1) Do not store components in corrosive condition such as chloric or sulfuric environment.
- 2) Components before use should be stored under the condition with temperature of 5 to 40 degrees Celsius and humidity of 20 to 70% RH.
- 3) It is recommended to use components within 6 months of incoming.
- 4) Do not open the minimal package until right before the use.
- 5) Do not store components under direct sunlight or dewy environment.

Screwdrivers

Please use proper screwdriver for adjustment of the capacitor. Kyocera can supply suitable ceramic type screwdrivers specially designed for the use of CTZ series. Please contact your local AVX office for the details.

CTZ-3

Pin Head

⊕: CTZ-3 Plus Ceramic Driver

CTZ-2

Pin Head

⊕: CTZ-2 Plus Ceramic Driver

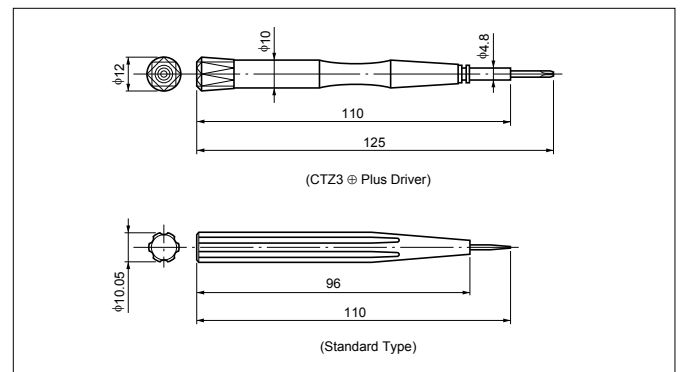

Driver Head Type

(CTZ3 Plus)

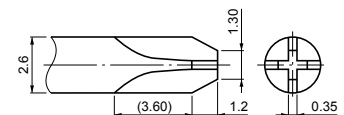

(CTZ2 Plus)

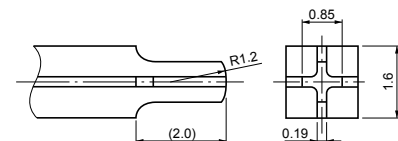

THE NEW VALUE FRONTIER



Resistors

Chip Resistor Arrays
Chip Resistor Networks
Attenuators
Low Resistance Chip Resistors



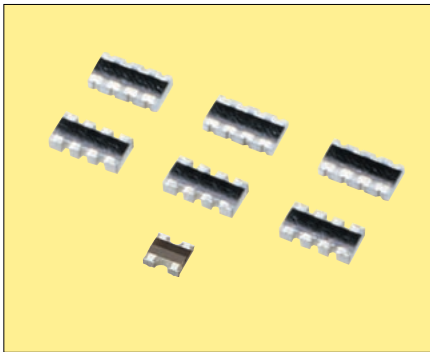

RoHS Compliant

Miniature chip resistor arrays have 4 and 2 resistor elements integrated as a single component.

Features

- Miniature (2.0×1.0mm) Resistor Arrays
 Max 60% space saving compared with the use of standard chip array (3.2×1.6mm)
- 0.5mm Termination pitch (Same as IC lead-pin pitch)
 Easy designing of pattern layout and improve electrical characteristics for circuit

*Please consult combination of different resistance type.

How to Order

CRB2A 4E 103 J T
 ① ② ③ ④ ⑤

- ① Series(CRB2A: 2.0×1.0mm, concave termination, 4elements)
 (CRC2A: 2.0×1.0mm, convex termination, 4elements)
 (CRC11A: 1.0×1.0mm, convex termination, 2elements)

- ② Number of elements(4E: 4 elements)
 (2E: 2 elements)

- ③ Resistance Value(3 digits numbering)
 472 = 4.7kΩ, 103 = 10kΩ
 000 = 0Ω(Chip Jumper Array)

- ④ Tolerance

J	±5%	Blank	Chip Jumper Array
----------	-----	--------------	-------------------

- ⑤ Packaging

	Code	Style	Form	Material	Packing unit
• 4 element chip Resistors Array	CRB2A4E series (Concave Termination)	H	CRB2A	Taping	Paper 10000pcs/reel
• 2 element chip Resistors Array	CRC11A2E series (Convex Termination)	T	CRC11A	Taping	Paper 10000pcs/reel
			CRB2A/CRC2A	Taping	Paper 10000pcs/reel (*2mm pitch taping)

Dimensions

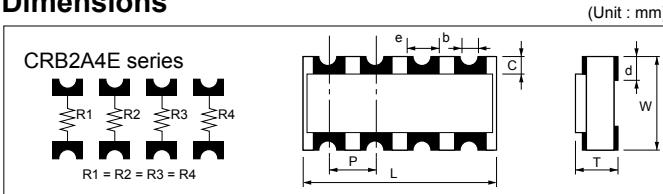

Code	L	W	T	P	b
Dimensions	2.0 ^{+0.10} _{-0.10}	1.0 ^{+0.10} _{-0.10}	0.4 ^{+0.10} _{-0.10}	0.5typ	φ0.15typ
Code	c	d	e		
Dimensions	0.2 ^{+0.15} _{-0.15}	0.25 ^{+0.15} _{-0.15}	0.25typ		

• Non-marking on chips

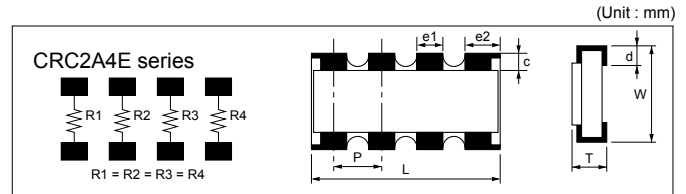

Code	L	W	T	P
Dimensions	2.0 ^{+0.10} _{-0.10}	1.0 ^{+0.10} _{-0.10}	0.4 ^{+0.10} _{-0.10}	0.5typ
Code	c	d	e1	e2
Dimensions	0.15 ^{+0.15} _{-0.15}	0.25 ^{+0.15} _{-0.15}	0.3 ^{+0.10} _{-0.10}	0.4 ^{+0.10} _{-0.10}

• Non-marking on chips

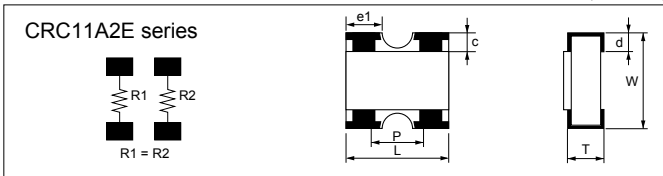

Code	L	W	T	P
Dimensions	1.00 ^{+0.10} _{-0.10}	1.00 ^{+0.10} _{-0.10}	0.35 ^{+0.05} _{-0.05}	0.65typ
Code	c	d	e1	
Dimensions	0.20 ^{+0.15} _{-0.15}	0.20 ^{+0.15} _{-0.15}	0.33 ^{+0.10} _{-0.10}	

• Non-marking on chips

Rating

Chip resistor arrays		Chip jumper array	
Item	Rating	Item	Rating
Rated power(70°C)	1/32W/element	Rated current	1A
Max working * voltage	25V		
Max Over-load voltage	50V		
Resistance value	10Ω to 1MΩ	Conductive resistance value	50mΩmax
Tolerance	J : ±5%		
Working Temperature	-55 to +125°C		
Number of elements	4E : 4Elements, 2E : 2Elements		

* Rated Voltage : √Rated power × Resistance value, whichever is less.

* Standard Resistance Value: E-6 Series

* Please contact sales engineer for any other requirements of the nominal resistance value and the tolerance.

8 element chip Resistor Array / CRC4A8E series (Convex Termination)

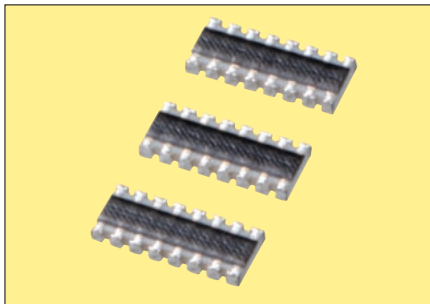

RoHS Compliant

Features

- 0.5mm termination pitch (same as IC lead-pin pitch).
- Easy designing of pattern layout and improve electrical characteristics for circuit.
- 3.8mm length of the chip makes the assembly of the next chip possible without changing the pattern pitch.

How to Order

CRC4A 8E 103 J T

① ② ③ ④ ⑤

- ① Series CRC4A
- ② Number of elements
8E = 8 elements
- ③ Resistance value
3 digits numbering
- ④ Tolerance

J	±5%
---	-----

- ⑤ Packaging

T	Taping paper 5,000pcs/reel
---	----------------------------

Dimensions

(Unit : mm)

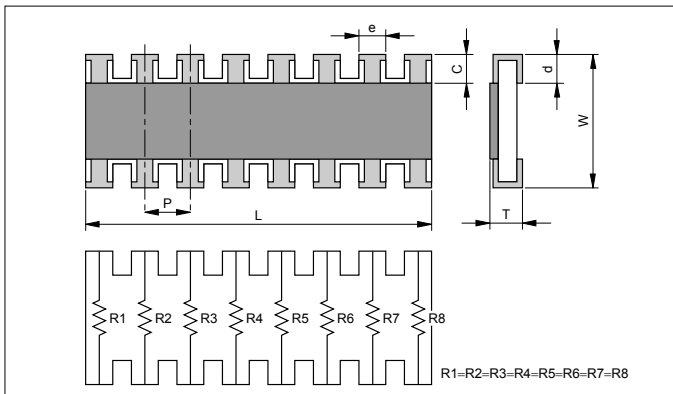

Code	Dimensions
L	3.8±0.1
W	1.6±0.1
T	0.45±0.1
P	0.5typ
c	0.3±0.2
d	0.3±0.15
e	0.3±0.1

• No marking on chips.

Rating

Chip Resistor Arrays	
Item	Rating
Rated power (70°C)	1/16W/element 1/4W/package
Max working voltage*	25V
Max over-load voltage	50V
Resistance value	10Ω to 1MΩ
Tolerance	J:±5%
Working temperature	-55 to +125°C
Number of elements	8E:8elements

- * Rated Voltage : $\sqrt{\text{Rated power} \times \text{Resistance value}}$, whichever is less.
- * Standard Resistance Value: E-6 Series
- * Please contact sales engineer for any other requirements of the nominal resistance value and the tolerance.

8 element chip Resistor Array / CRB6A8E series (Concave Termination)

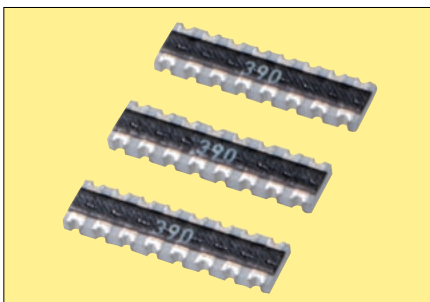

RoHS Compliant

Features

- Equal length conductors can be traced out from 0.8mm pitch termination.

How to Order

CRB6A 8E 390 G U

① ② ③ ④ ⑤

- ① Series CRB6A
- ② Number of elements
8E = 8 elements
- ③ Resistance value
3 digits numbering
- ④ Tolerance

G	±2%	J	±5%
---	-----	---	-----

- ⑤ Packaging

U	Taping plastic 4,000pcs/reel
---	------------------------------

Dimensions

(Unit : mm)

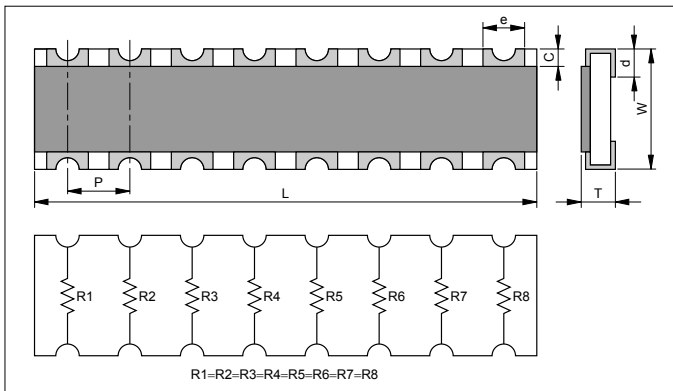

Code	Dimensions
L	6.4±0.2
W	1.6±0.2
T	0.6±0.1
P	0.8typ
c	0.3±0.2
d	0.4±0.15
e (Top side)	0.5±0.1
e (Bottom side)	0.4±0.15

Rating

Chip Resistor Arrays	
Item	Rating
Rated power (70°C)	1/16W/element
Max working voltage*	50V
Max over-load voltage	100V
Resistance value	10Ω to 1MΩ
Tolerance	G:±2%, J:±5%
Working temperature	-55 to +125°C
Number of elements	8E:8elements

- * Rated Voltage : $\sqrt{\text{Rated power} \times \text{Resistance value}}$, whichever is less.
- * Standard Resistance Value: E-6 Series
- * Please contact sales engineer for any other requirements of the nominal resistance value and the tolerance.

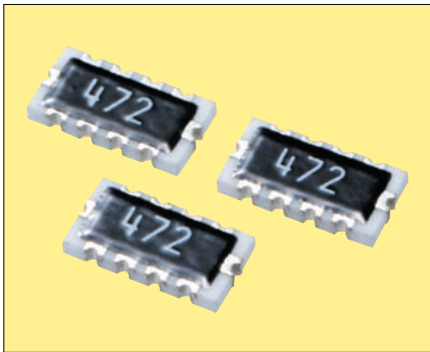

RoHS Compliant

Features

- Reduction in mounting costs & Process
- Save PCB space
- Eight resistors in one SMD package
- Reduction of inventory control costs

Applications

- Lap Top Computer
- Notebook Computer
- Printer
- Hard Disk Drive
- CD ROM
- Facsimile

How to Order

RNA4A 8E 103 J U
① ② ③ ④ ⑤

- ① Series
- ② Number of elements (8E : 8 elements)
- ③ Resistance code (3 digits)
- ④ Resistance tolerance (J : ±5%)
- ⑤ Packaging

U Plastic Taping, 4,000pcs/reel

* Taping Qty: 4000pcs/7 inch reel (4mm pitch)
Carrier Tape: plastic

Shape and Dimensions

(Unit : mm)

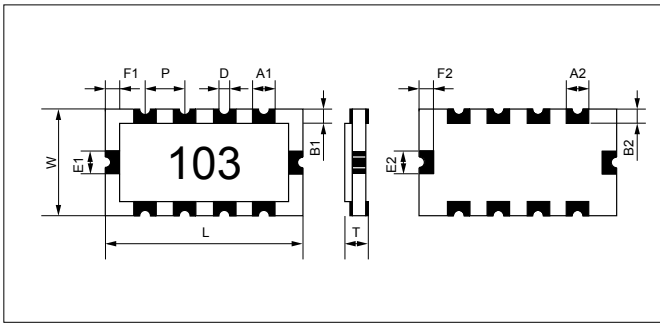

Code	L	W	T	A1	B1
Dimensions	4.0±0.15	2.1±0.15	0.6±0.1	0.5±0.1	0.25±0.15
Code	E1	F1	D	P	A2
Dimensions	0.5±0.1	0.3±0.15	0.3typ	0.8typ	0.4±0.1
Code	B2	E2	F2		
Dimensions	0.4±0.15	0.5±0.1	0.35±0.15		

Circuit Diagram

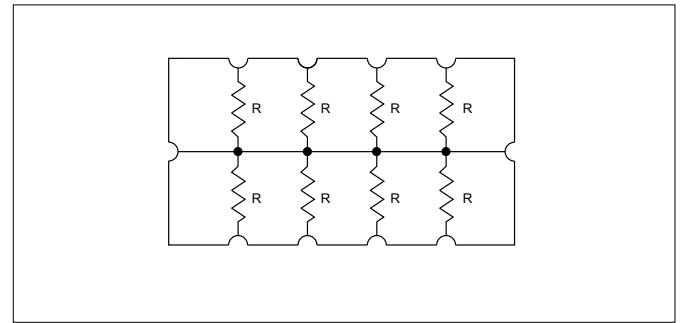

* nominal resistance value is all the same.

Specifications

Item	Rating
Rated power (70°C)	1/16W(0.0625W)/Element
Max working voltage*	25V
Max over-load voltage	50V
Resistance value	100Ω to 220KΩ
Tolerance	J:±5%
Number of elements	8E:8 Elements
Working temperature	-55 to +125°C

* Rated Voltage: √Rated power ×Resistance value, whichever is less.

* Standard Resistance Value: E-6 Series

* If resistance value under 100Ω is needed, please contact sales.

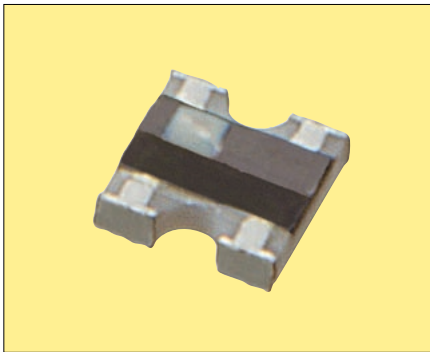

RoHS Compliant

Features

- Compared with three past in the chip resistor use, reduction in mounting costs and process, save PCB space

How to Order

ATC 1A 2 C H
① ② ③ ④ ⑤

- ① Series
- ② Size (1A : 1.0×1.0mm)
- ③ Attenuation (1 digit numbering)
1: 1dB, 2: 2dB, 3: 3dB, 4: 4dB, 5: 5dB
6: 6dB, 7: 7dB, 8: 8dB, 9: 9dB, A: 10dB
- ④ Attenuation tolerance

C	±0.3dB	D	±0.5dB
----------	--------	----------	--------

- ⑤ Packaging

Code	Form	Material	Packing unit
H	Taping	Paper	10000pcs/reel

* 2mm pitch taping

Dimensions

(Unit : mm)

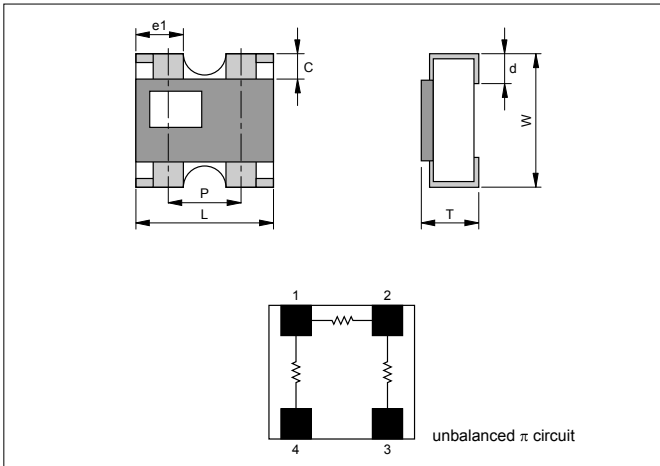

Code	L	W	T	P	c
Dimensions	1.00±0.10	1.00±0.10	0.35±0.05	0.65typ	0.20±0.15
Code	d	e1			
Dimensions	0.20±0.15	0.33±0.10			

Rating

Chip attenuators	
Item	Rating
Impedance	50Ω
Attenuation	1dB, 2dB, 3dB, 4dB, 5dB 6dB, 7dB, 8dB, 9dB, 10dB
Attenuation tolerance	±0.3dB: 1dB to 5dB ±0.5dB: 6dB to 10dB
Rated power	40mW/package
Applicable frequency	DC to 2GHz
VSWR	1.3 max
Working temperature	-55 to +125°C

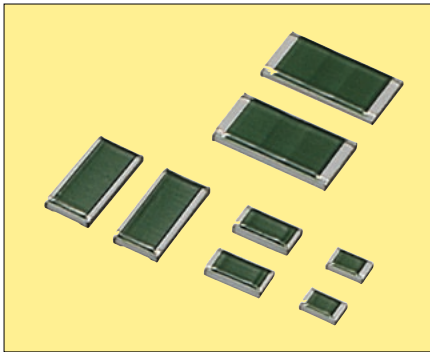

RoHS Compliant

Features

- Suitable for voltage detector circuit of mobile computing device and cellular phone.

How to Order

LR 21 - R100 F - T
① ② ③ ④ ⑤

- ① Series LR
- ② Size (EIA)

21	0805	50	1020
32	1206	63	2512

- ③ Resistance Value (4 digits)
R047 = 47mΩ
R330 = 330mΩ
1R00 = 1000mΩ
- ④ Tolerance

K	±10%
F	±1%

- ⑤ Packaging

T	Paper Taping(LR21, LR32), 5,000pcs/7"reel
U	Plastic Taping(LR50, LR63), 4,000pcs/7"reel

Dimensions

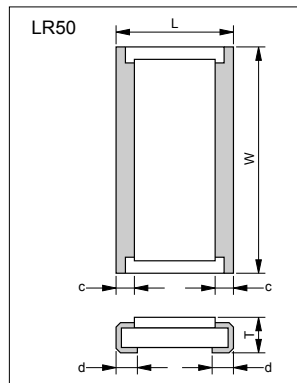
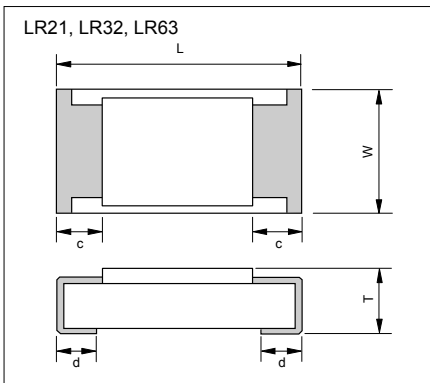

*No marking

(Unit : mm)

	W	L	c	d	T
LR21 (0805)	1.25 ^{+0.15} _{-0.15}	2.00±0.10	0.25±0.20	0.40±0.20	0.55±0.10
LR32 (1206)	1.55 ^{+0.15} _{-0.15}	3.10±0.10	0.25±0.20	0.45±0.20	0.55 ^{+0.10} _{-0.10}
LR50 (1020)	5.00±0.20	2.50±0.20	0.20±0.15	0.50±0.20	0.60±0.10
LR63 (2512)	3.20±0.20	6.30±0.20	0.45±0.20	0.45±0.20	0.60±0.10

Specifications

Series	Item	Rated power	Max working voltage	Resistance tolerance	Resistance value	Working temperature	Temperature characteristics
LR21 (0805)	0.25W (1/4W)	287mV	F: ±1%	100 to 149mΩ	-55 to +125°C	±150ppm/°C	
				150 to 330mΩ		±100ppm/°C	
LR32 (1206)	0.5W (1/2W)	707mV	K: ±10%	20 to 50mΩ	-55 to +125°C	±3000ppm/°C	
				100 to 149mΩ		±150ppm/°C	
LR50 (1020)	1W	316mV	F: ±1%	150 to 1000mΩ	-55 to +125°C	±100ppm/°C	
				20 to 29mΩ		±150ppm/°C	
LR63 (2512)	1W	1000mV	F: ±1%	30 to 100mΩ	-55 to +125°C	±100ppm/°C	
				100 to 1000mΩ		±150ppm/°C	

Electrical Characteristics

Item	Standard		Test Conditions									
	Resistor	Jumper	Resistor	Jumper								
DC Resistance	Within Initial Tolerance		Power Condition A (20°C, 65%RH)									
Temperature Characteristics	<table border="1"> <thead> <tr> <th>Resistance(Ω)</th> <th>TCR(ppm/°C)</th> </tr> </thead> <tbody> <tr> <td>R <10</td> <td>-100 to +600</td> </tr> <tr> <td>10 ≤ R ≤ 1M</td> <td>-250 to +250</td> </tr> <tr> <td>1M < R</td> <td>-500 to +300</td> </tr> </tbody> </table>	Resistance(Ω)	TCR(ppm/°C)	R <10	-100 to +600	10 ≤ R ≤ 1M	-250 to +250	1M < R	-500 to +300	50mΩmax	Test Temperature: 25,125(°C) $\Delta R/R = R_2 - R_1 / R_1 \times 1 / T_2 - T_1 \times 10^6$ ΔR/R: Temp. Coefficient (ppm/°C) T ₁ : 25(°C) T ₂ : 125(°C) R ₁ : T ₁ Resistance at (Ω) R ₂ : T ₂ Resistance at (Ω)	
	Resistance(Ω)	TCR(ppm/°C)										
R <10	-100 to +600											
10 ≤ R ≤ 1M	-250 to +250											
1M < R	-500 to +300											
Short-time Overload	ΔR/R	±(2.0%+0.10Ω)max of the initial value	50mΩmax	(1) Apply 2.5×rated voltage for 5sec. (2) Wait 30minutes (3) Measure resistance	(1) 2A for 5sec. (2) Wait 30minutes (3) Measure resistance							
	Visual	No evidence of mechanical damage intermittent overload										
Intermittent Overload	ΔR/R	±(5%+0.1Ω)max of the initial value	50mΩmax	(1) Perform 10000voltage cycles as follows: ON (2.5×rated voltage) 1sec. OFF 25sec. (2) Stabilization time 30min without loading (3) Measure resistance	(1) Perform 10000 current cycles as follows: ON (2A) 1sec. OFF 25sec. (2) Wait 30minutes (3) Measure resistance							
	Visual	No evidence of mechanical damage										
Dielectric Withstanding Voltage	No evidence of mechanical damage		Apply 300VAC for 1sec									
Insulation Resistance	10 ⁹ Ωmin		<p>Apply 100V DC.</p>									



Mechanical Characteristics

Item		Standard		Test Conditions	
		Resistor	Jumper	Resistor	Jumper
Terminal Strength	ΔR/R	±(1%+0.05Ω)max of the initial value	50mΩmax	Apply the load as show: Measure resistance during load application Unit: mm 	
	Visual	No evidence of mechanical damage after loading			
Soldering Heat Resistance	ΔR/R	±(1%+0.05Ω)max of the initial value	50mΩmax	Immerse into molten solder at 260±5°C for 10±1sec. Stabilize component at room temperature for 1hr. Measure resistance.	
	Visual	No evidence of leaching			
Solderability		Coverage ≥95% each termination end		Immerse in Rogin Flux for 2±0.5 sec. and in SN62 solder at 235±5°C for 2±0.5 sec.	
Anti-Vibration Test	ΔR/R	±(1%+0.1Ω)max of the initial value	50mΩmax	2 hrs. each in X, Y and Z axis. (TTL 6hrs.)10 to 55 Hz sweep in 1min.at 1.5mm amplitude.	
	Visual	No evidence of mechanical damage			
Solvent Resistance	ΔR/R	±(0.5%+0.05Ω)max of the initial value	50mΩmax	Immerse in static state butyl acetate at 20°C to 25°C for 30±5sec. Stabilize component at room temperature for 30min then measure Value.	
	Visual	No evidence of mechanical damage			

Environmental Characteristics

Item		Standard		Test Conditions	
		Resistor	Jumper	Resistor	Jumper
Temperature Cycle	ΔR/R	±(1%+0.05Ω)max of the initial value	50mΩmax	1) Run 5cycles as follows: -55±3°C for 30min. 125±3°C for 30min. Room temp for 10-15min. 2) Stabilize component at room temperature for 1hr. then measure value.	
	Visual	No evidence of mechanical damage			
Low Temperature Storage	ΔR/R	±(2%+0.1Ω)max of the initial value	50mΩmax	1) Dwell in -55°C chamber without loading for 1000 ^{±48} hrs. 2) Stabilize component at room temperature for 1hr. then measure value.	
	Visual	No evidence of mechanical damage			
High Temperature Storage	ΔR/R	±(3%+0.1Ω)max of the initial value	50mΩmax	1) Dwell in 125°C chamber without loading for 1000 ^{±48} hrs. 2) Stabilize component at room temperature for 1hr. then measure value.	
	Visual	No evidence of mechanical damage			
Moisture Resistance	ΔR/R	±(3%+0.1Ω)max of the initial value	50mΩmax	1) Dwell in temp: 65°C RH90 to 95%RH chamber without loading for 1000 ^{±48} hrs. 2) Stabilize component at room temperature for 1hr. then measure value.	
	Visual	No evidence of mechanical damage			
Life Test	ΔR/R	±(3%+0.1Ω)max of the initial value	50mΩmax	1) Temp: 70±3°C Voltage: (rated voltage) on 90 min off 30min. Duration: 1000 ^{±48} hrs. 2) Stabilize component at room temperature for 1hr. then measure value.	
	Visual	No evidence of mechanical damage			
Loading Life in Moisture	ΔR/R	±(3%+0.1Ω)max of the initial value	50mΩmax	1) Temp: 40±2°C RH: 90-95% Voltage Cycle: on 90 min(rated voltage) off 30min. Duration: 1000 ^{±48} hrs. 2) Stabilize component at room temperature for 1hr. then measure value.	
	Visual	No evidence of mechanical damage			

Tape & Reel

• Reel

(Unit : mm)

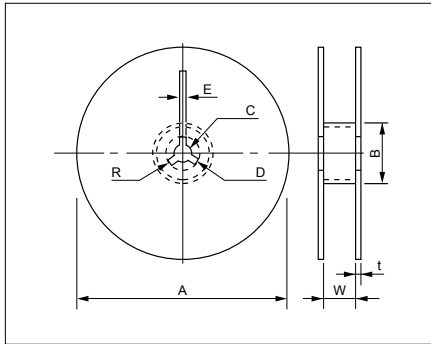

Code	A	B	C	D	E	W	t	R
Width: 8mm	$\phi 178 \pm 2.0$	$\phi 50 \text{min.}$	$\phi 13.0 \pm 0.5$	$\phi 21.0 \pm 0.8$	2.0 ± 0.5	10.0 ± 1.5	2.5MAX.	1.0
Width: 12mm						13.0 ± 1.5		

• Carrier Tape (8mm)

(Unit : mm)

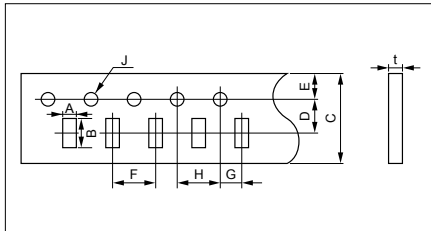

Dimension Code TYPE	A	B	C	D	E	F	G	H	J	t
0404	1.2 ± 0.1	1.2 ± 0.1	8.0 ± 0.2	3.5 ± 0.05	1.75 ± 0.1	2.0 ± 0.1	2.0 ± 0.05	4.0 ± 0.1	$\phi 1.5 \text{ } ^{-0.1}$	0.6max.
0804	1.25 ± 0.2	2.25 ± 0.2								1.1max.
0805	1.65 ± 0.2	2.4 ± 0.2				4.0 ± 0.1				
1206	2.0 ± 0.2	3.6 ± 0.2								
1506	1.9 ± 0.2	4.1 ± 0.2								

• Carrier Tape (12mm)

(Unit : mm)

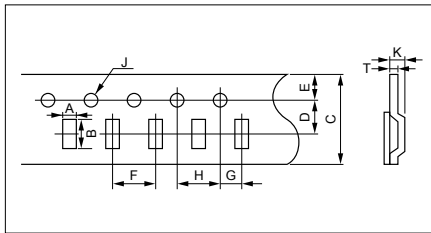

Dimension Code TYPE	A	B	C	D	E	F	G	H	J	T	K
1020	2.9 ± 0.2	5.3 ± 0.2	12.0 ± 0.3	5.5 ± 0.05	1.75 ± 0.1	4.0 ± 0.1	2.0 ± 0.1	4.0 ± 0.1	$\phi 1.5 \text{ } ^{-0.1}$	0.6max.	1.4max.
1608	2.5 ± 0.2	4.4 ± 0.2									
2512	3.5 ± 0.2	6.7 ± 0.2									
2506	2.0 ± 0.2	6.9 ± 0.2									

• Taping Quantity per reel

(Unit : pcs)

TYPE	Series	Paper ($\phi 178$ reel)
0404	CRC11A2E, ATC1A	10000 (2mm pitch)
0804	CRB2A4E, CRC2A4E	10000 (2mm pitch)
0805	LR21	5000 (4mm pitch)
1206	LR32	5000 (4mm pitch)
1506	CRC4A8E	5000 (4mm pitch)
1020	LR50	4000 (4mm pitch)
1608	RNA4A	4000 (4mm pitch)
2512	LR63	4000 (4mm pitch)
2506	CRB6A8E	4000 (4mm pitch)

Recommended Land Patterns

Chip Type

(Unit : mm)

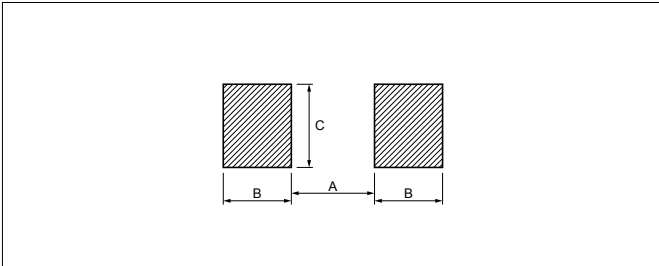

EIA Size	A	B	C
0805	1.0	0.8	1.2
1206	2.2	0.9	1.5
1020	1.4	1.0	5.0
2512	5.0	1.0	3.0

Array Type

(Unit : mm)

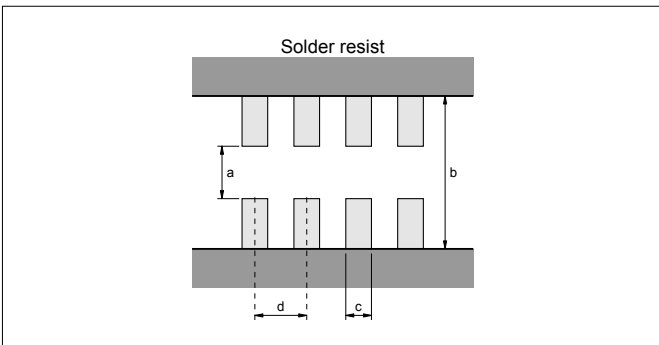

Series	a	b	c	d
CRB2A4E	0.4	1.5	0.25	0.5
CRC11A2E	0.5	1.5	0.4	0.65
CRC4A8E	0.8	2.4	0.3	0.5
CRB6A8E	0.7	2.3	0.4	0.8
ATC1A	0.5	1.5	0.4	0.65

(Unit : mm)

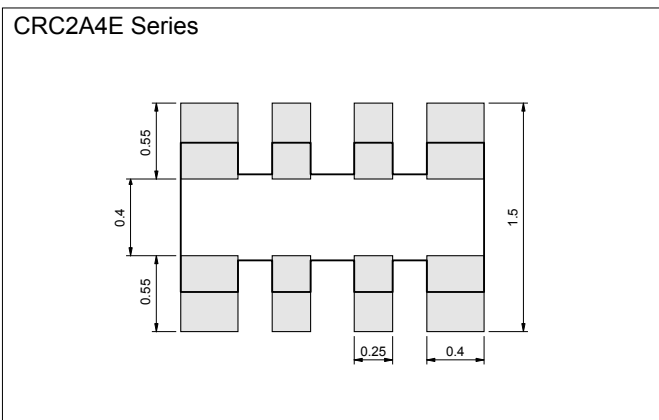

(Unit : mm)

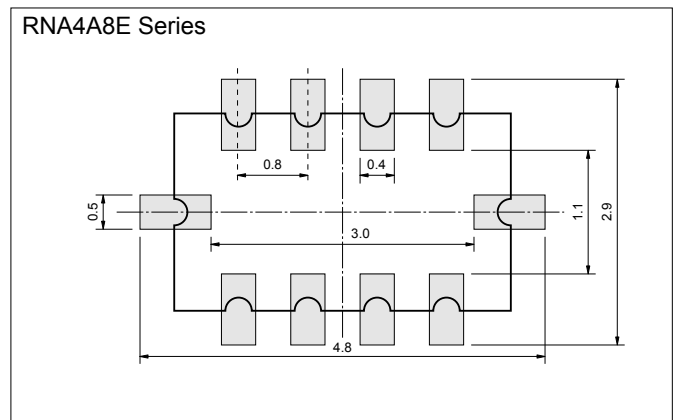

Circuit design

- 1) Once application and assembly environments have been checked, the resistors may be used in conformance with the catalog and the specifications.
- 2) Please consult the manufacturer in advance when the resistors is used in devices such as: devices which deal with human life, i.e. medical devices; devices which are highly public orientated; and devices which demand a high standard of liability.
- 3) Please use the resistors in conformance with the operating temperature provided in both the catalog and the specifications.
- 4) Please keep voltage under the rated voltage which is applied to the resistor.
- 5) Do not use the resistor in an environment where it might easily exceed the respective provisions concerning shock and vibration specified in the catalog and specifications.
- 6) Please do not use the resistor in the following environments.
 - ① State that water, oil, and solvent hang in resistor
 - ② State where poisonous gas (sulfur and chlorine, etc.) exists
 - ③ State that direct sunshine, radiation, and ultraviolet, etc. are irradiated
- 7) There is a thing that resistance changes according to the stuff of the resin when the coating with the resin is given. Please use resin coating after confirming the characteristic.
- 8) There is a thing that resistance changes according to flux and cleaner. Please use flux and cleaner after confirming the characteristic.
- 9) Please consult about a lead free products.

Storage

- 1) Keep storage place temperature +5 to +35°C, humidity 45 to 75% RH.
- 2) Please keep parts out of poisonous gas such as sulfur or chlorine in the air, and out of salty moisture. Or they may cause rust of terminal, and poor solderability. and, please consider the above-mentioned item after mounting your company.
- 3) Soldering iron

Temperature	soldering iron 300±5°C *
Time	3 sec. max. *

*Do not place the soldering iron on the chip. Soldering iron is 30W max.

Soldering method

1) Recommendable temperature profile

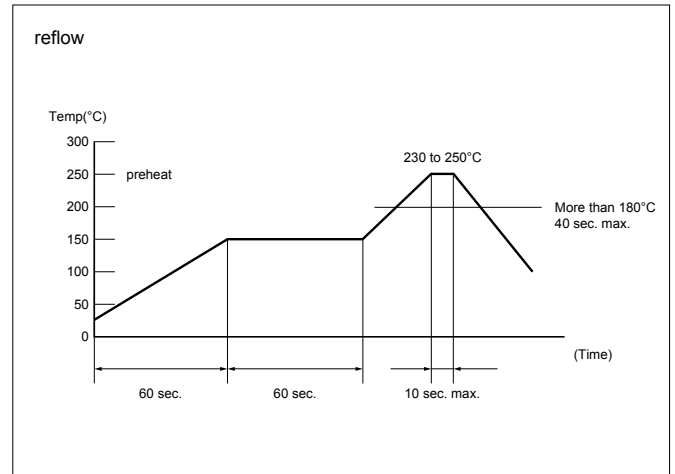

2) Recommendable temperature profile

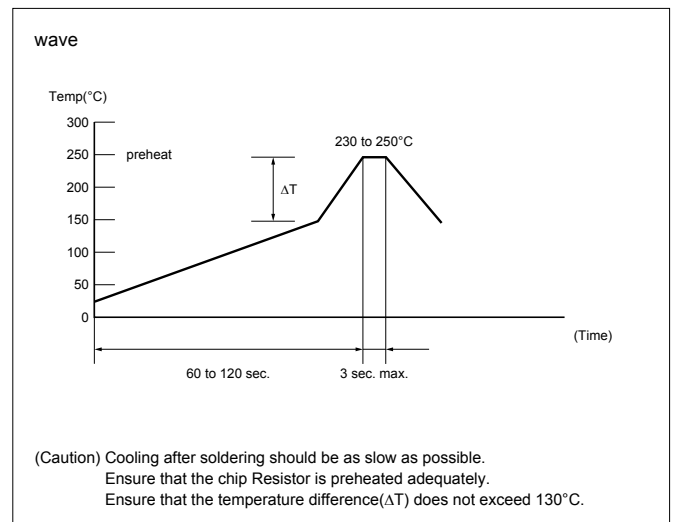

3) pb-free recommendable temperature profile

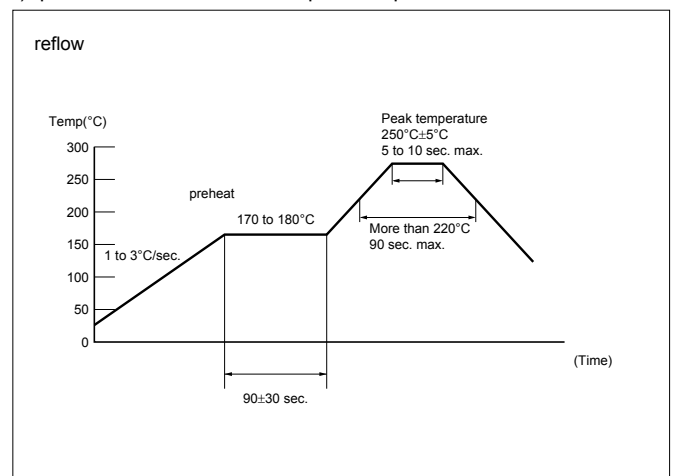

THE NEW VALUE FRONTIER



EMC Components

EMI Filters



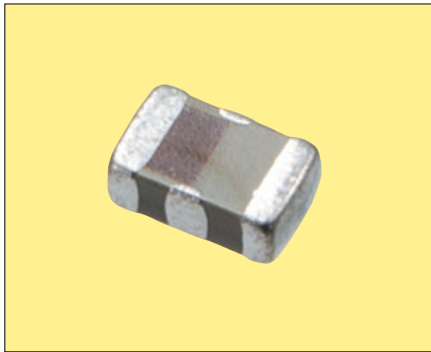

RoHS Compliant

Features

- Distributed constant type LC filter. Prevents ringing caused by circuit impedance. Suitable for high speed digital circuits and video signal lines.
- Stable noise attenuation over wide frequency ranges.
- Low profile (T=0.95mm max.) suitable for miniature electronic equipments.
- First class auto-placement

Applications

- PCs, Laser Printers, Cellular Phone, Clock Data Lines for LCD Display
- High Speed Video Signal Circuits and Interface Circuits
- High Speed Digital Circuits
- Anti-Noise Solution
Achieves Effective Noise Suppression in Noisy High Speed Circuits without Signal Waveform Distortion

How to Order

KNF 21 050 - W 3
① ② ③ ④ ⑤

- ① Series
- ② Size EIA (EIAJ)
21 :0805 (2012)
- ③ Frequency

025	25MHz	200	200MHz
050	50MHz	400	400MHz
100	100MHz		

- ④ Taping Direction (See Fig 1)
W: Standard
- ⑤ Quantity per Reel

3	3000pcs.
----------	----------

Dimensions

(Unit : mm)

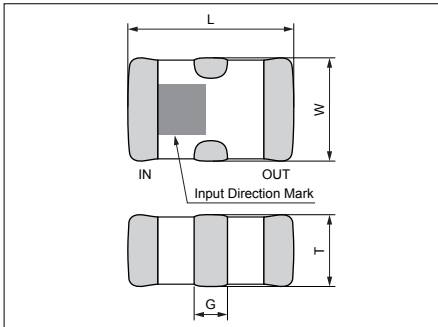

KNF21	
L	2.0±0.2
W	1.25±0.2
T	0.8±0.15
G	0.4±0.3

Specifications

Part Number	Cut off Freq. (MHz)	Capacitance (+50/-20%) (pF)	20dB Attenuation (Typical)	Rated current(mA)	Rated voltage(VDC)
KNF21025	25MHz	235pF	200- 600MHz	150mA	25VDC
KNF21050	50MHz	130pF	350- 850MHz		
KNF21100	100MHz	65pF	450- 950MHz		
KNF21200	200MHz	33pF	700-1200MHz		
KNF21400	400MHz	17pF	900-1400MHz		

*Cut off Frequency at Attenuation typical 3dB, max. 6dB
Operating Temperature: -25 to 85(°C)

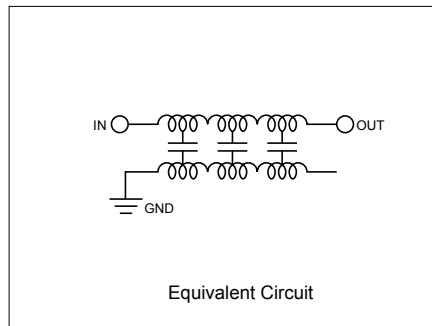

Frequency Characteristics

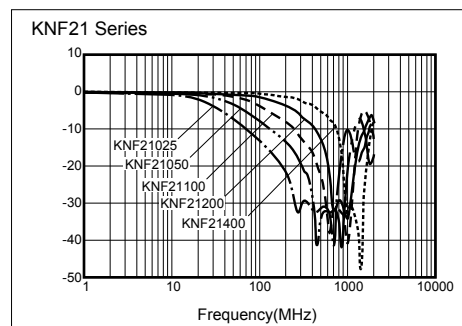

<Impedance Matching Free>

- Stable attenuation against impedance change
- Good impedance matching without ringing on distortion even at the time of IC ON/OFF and pattern layout change

Test circuit

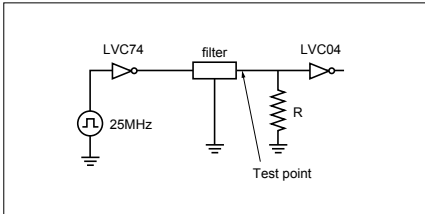

Output Waveform (Clock frequency 25MHz)

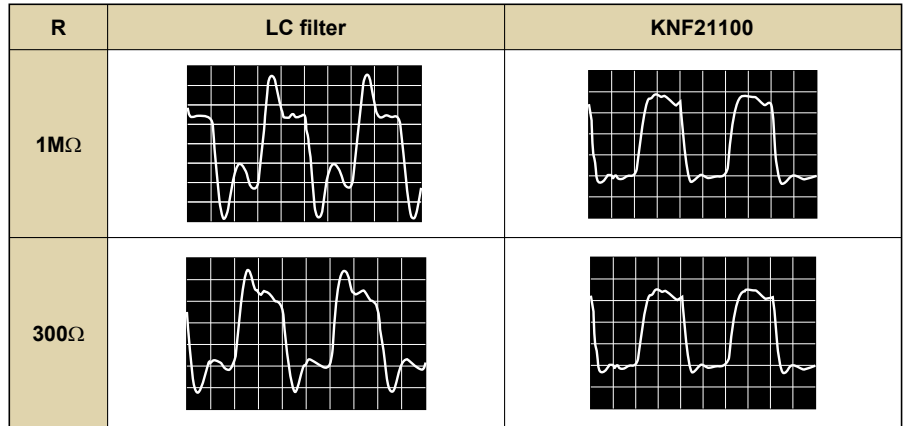

<No Ringing>

Excellent Impedance Matching

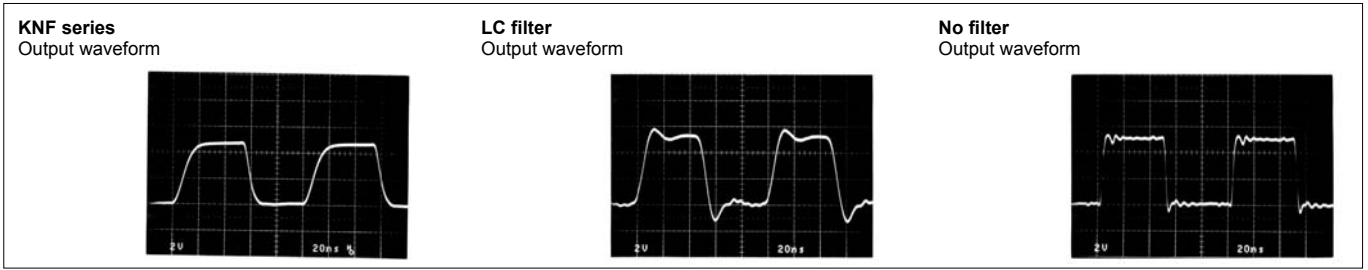

- Wide attenuation up to high frequency range without distortion

Wide Attenuation Bandwidth

Test Circuit

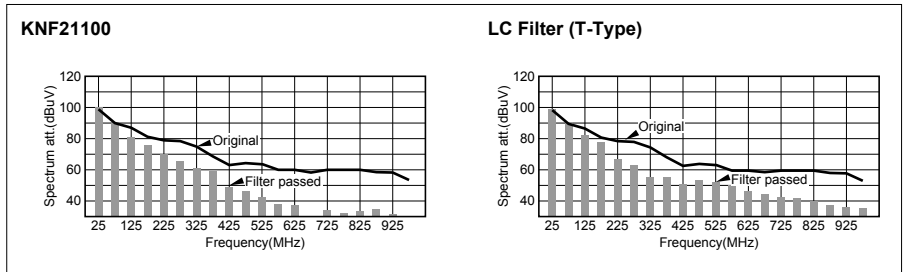
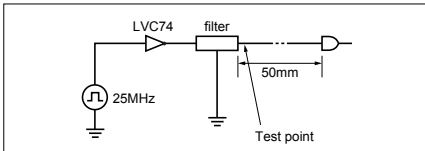

Recommended Land Pattern

(Unit : mm)

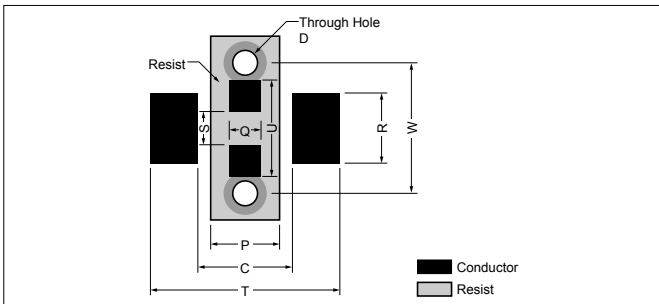

	T	W	R	C	P	Q	S	D	U
KNF21	3.20	2.30	1.00	1.20	0.80	0.40	0.60	0.3-0.4	2.00

Packaging Specification (Fig.1)

- Taping (3,000/reel)

(Unit : mm)

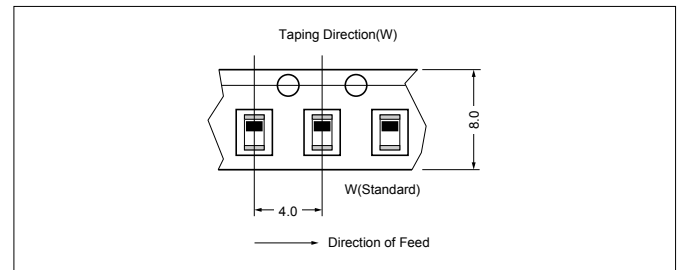

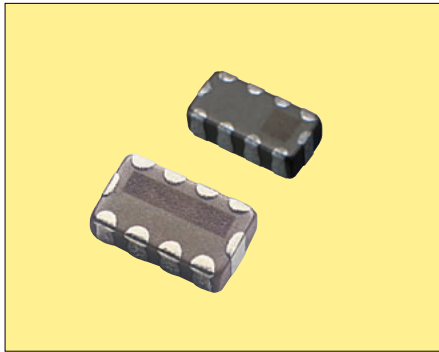

RoHS Compliant

Features

- Distributed constant type LC filter. Prevents ringing caused by circuit impedance. Suitable for high speed digital circuits and video signal lines.
- Stable noise attenuation over wide frequency ranges.
- Small and low profile.

Applications

- Data Lines for Mobile Phones (LCD Lines, Video Lines, Bus Lines)
- Bus Lines for Digital Equipment

How to Order

KNA 16 300 - W 3
 ① ② ③ ④ ⑤

- ① Series
- ② Size

	EIA	EIAJ
16	0603	1608
21	0805	2012

- ③ Frequency

300(KNA16)	300MHz
400(KNA21)	400MHz

*Frequency at Attenuation typical 3dB, max. 6dB

- ④ Taping Direction
W: Standard

- ⑤ Quantity per Reel

3	3000pcs.	KNA21 : std.
4	4000pcs.	KNA16 : option
5	5000pcs.	KNA16 : std.

Specifications

Part Number	Cut off Freq. (MHz)	Capacitance (+25/-20%) (pF)	Attenuation (Typical)	Rated current(mA)	Rated voltage(VDC)
KNA16300	300MHz	16pF	800-1000MHz@-25dB	35mA	25VDC
KNA21301	300MHz	15pF	800-2000MHz@-20dB	35mA	25VDC
KNA21400	400MHz	18pF	800-1000MHz@-20dB	50mA	25VDC

Operating Temperature: -25 to 85(°C)

Dimensions

(Unit : mm)

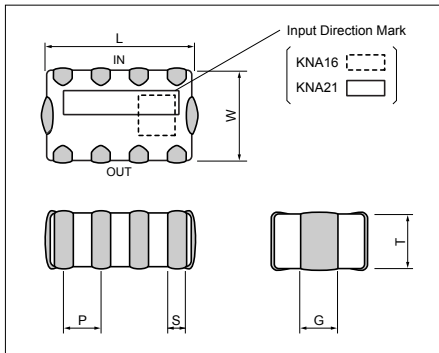

Frequency Characteristics

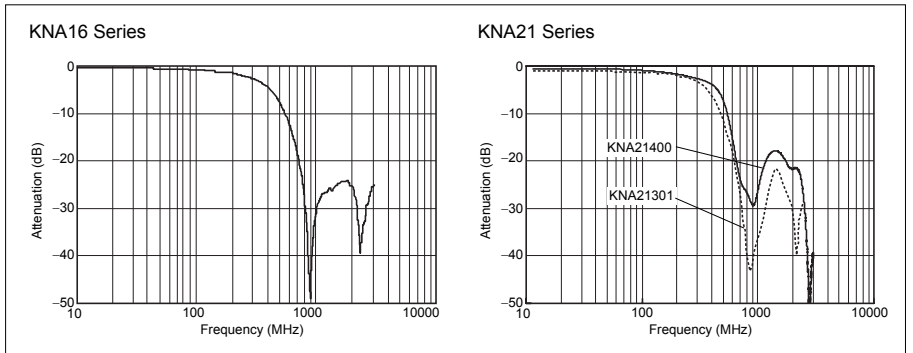

	L	W	T	P	S	G
KNA16	1.60±0.08	0.8±0.08	0.50±0.1	0.40	0.20±0.075	0.20±0.075
KNA21	2.0±0.2	1.25±0.2	0.7±0.15	0.50	0.25±0.1	0.40±0.15

Recommended Land Pattern

(Unit : mm)

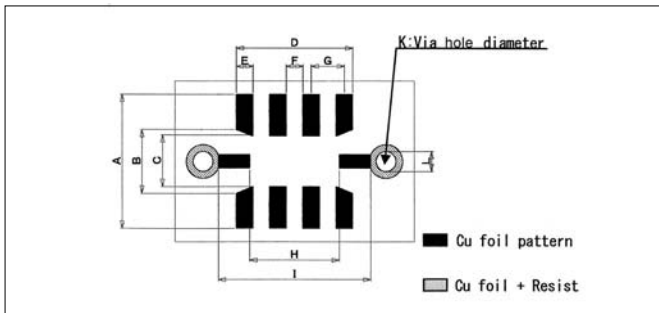

Packaging Specification

- Taping
 (KNA16 : 5,000/reel : STD.
 4,000/reel : Opt.
 KNA21 : 3,000/reel : STD.)

(Unit : mm)

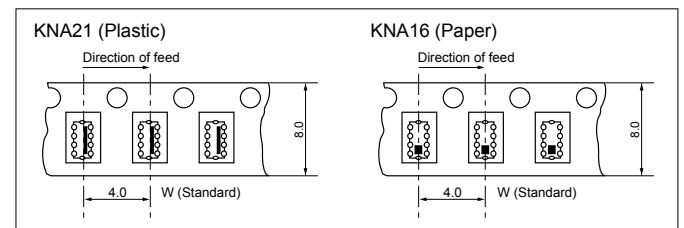

CODE	A	B	C	D	E	F	G	H	I	K	L
KNA16	1.10	0.60	0.50	1.40	0.20	0.20	0.40	1.30	1.80	0.20	0.20
KNA21	2.00	0.95	0.75	1.75	0.25	0.25	0.50	1.35	2.45	0.30	0.20

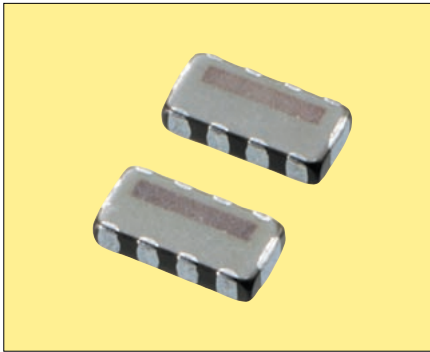

RoHS Compliant

Features

- Distributed constant type LC filter. Prevents ringing caused by circuit impedance. Suitable for high speed digital circuits and video signal lines.
- Stable noise attenuation over wide frequency ranges.
- Low profile (H=0.85mm max.) suitable for miniature electronic equipments.
- First class auto-placement

Applications

- PCs, Laser Printers, Cellular Phone, Clock Data Lines for LCD Display
- High Speed Video Signal Circuits and Interface Circuits
- High Speed Digital Circuits
- Anti-Noise Solution
- Achieves Effective Noise Suppression in Noisy High Speed Circuits without Signal Waveform Distortion

How to Order

KNA 32 050 - W 3
① ② ③ ④ ⑤

- ① Series
- ② Size EIA (EIAJ)
32 :1206 (3216)
- ③ Frequency

050	50MHz	200	200MHz
100	100MHz		

*Frequency at Attenuation typical 3dB, max. 6dB

- ④ Taping Direction (See Fig.1)
W: Standard
- ⑤ Quantity per Reel

3	3000pcs.
----------	----------

Specifications

Part Number	Cut off Freq. (MHz)	Capacitance (+25/-20%) (pF)	20dB Attenuation (Typecal)	Rated current(mA)	Rated voltage(VDC)
KNA32050	50MHz	115pF	350 – 850MHz	100mA	25VDC
KNA32075	75MHz	82pF	400 – 900MHz	100mA	25VDC
KNA32100	100MHz	65pF	450 – 950MHz	100mA	25VDC
KNA32150	150MHz	45pF	600–1100MHz	100mA	25VDC
KNA32200	200MHz	35pF	700–1200MHz	100mA	25VDC

Operating Temperature: -25 to 85(°C)

Dimensions

(Unit : mm)

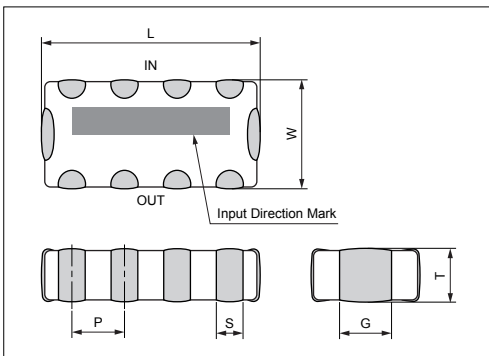

	KNA32
L	3.2±0.2
W	1.6±0.2
T	0.75±0.1
P	0.8
S	0.35±0.15
G	0.80±0.20

Frequency Characteristics

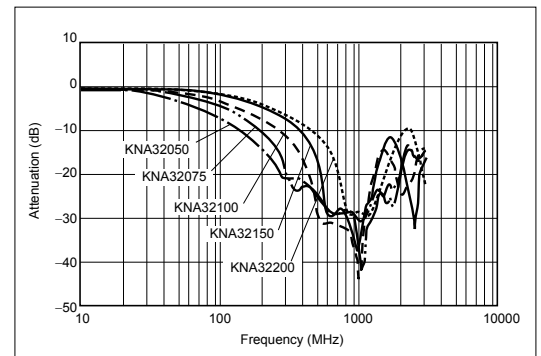

Recommended Land Pattern

(Unit : mm)

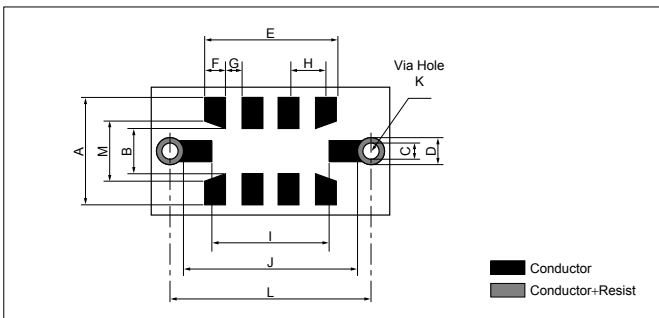

Packaging Specification (Fig.1)

- Taping (3,000/reel)

(Unit : mm)

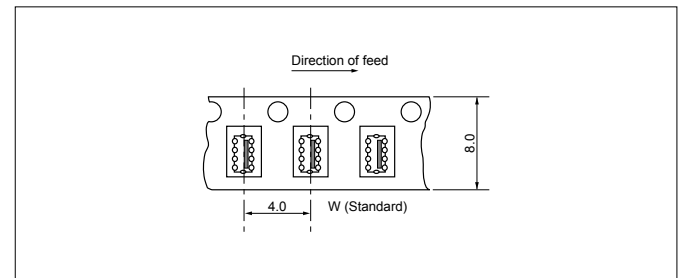

CODE	A	B	C	D	E	F	G	H	I	J	K	L	M
DIMENSION	2.2	1.0	0.4	0.6	2.8	0.4	0.4	0.8	2.6	3.8	0.3 to 0.4	4.2	1.3

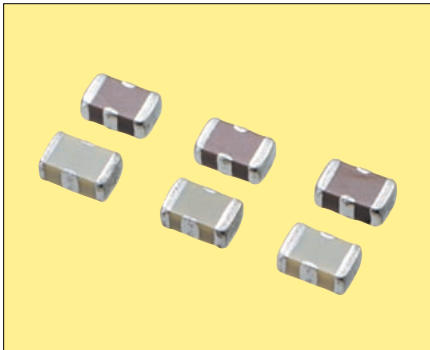

Pb Free

RoHS Compliant

Features

- 0805 Size. Rated current up to 2A.
- Effective for filtering noise on power (Vcc) lines.

Applications

- PCs, Laser Printers, Cellular Phone, Power/Signal Lines for LCD Display, Office Equipments
- AV Power Supply/Signal Line, TV, VCR, etc.
- High Current Signal Lines

How to Order

KNH 21 104 - 3 AA
① ② ③ ④ ⑤

- ① Series
- ② Size EIA (EIAJ)
21: 0805 (2012)
- ③ Capacitance Value

104	100nF	101	100pF
473	47nF	470	47pF
471	470pF	220	22pF
221	220pF		

- ④ Quantity per Reel

3	3000pcs.
----------	----------

- ⑤ Code (AA : STD)

Dimensions

(Unit : mm)

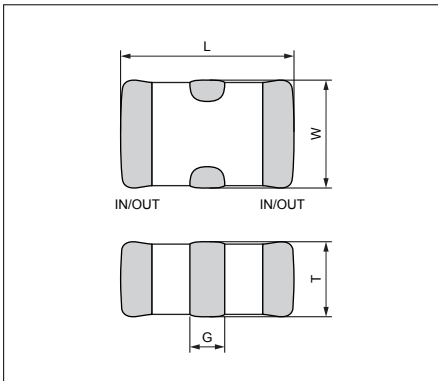

	KNH21
L	2.0±0.2
W	1.25±0.2
T	0.85±0.15
G	0.40±0.30

Specifications

Type	Capacitance Value(pF) (+50/-20%)	Rated Current (A)	Rated Voltage (VDC)	Direct-current resistance(Ω)
KNH21104	100,000	2.0	25	≤0.02
KNH21473	47,000	2.0	50	≤0.02
KNH21471	470	1.0	50	≤0.08
KNH21221	220	1.0	50	≤0.08
KNH21101	100	1.0	50	≤0.08
KNH21470	47	1.0	50	≤0.08
KNH21220	22	1.0	50	≤0.08

Operating Temperature: -25 to 85(°C)

Attenuation Characteristics

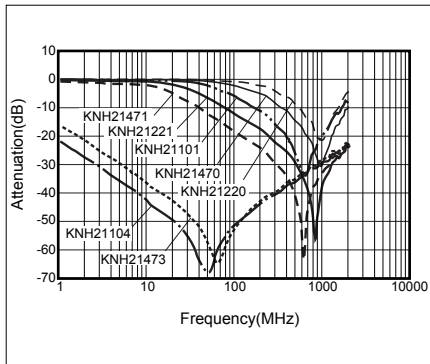

Recommended Land Pattern (Unit : mm)

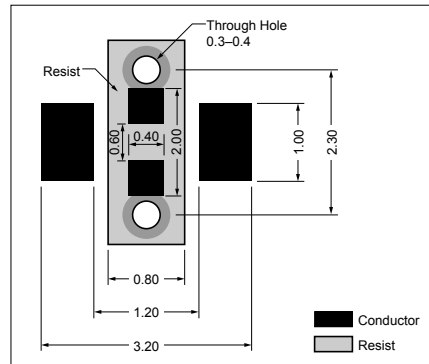

Packaging specifications

- Taping (3000/reel) (Unit : mm)

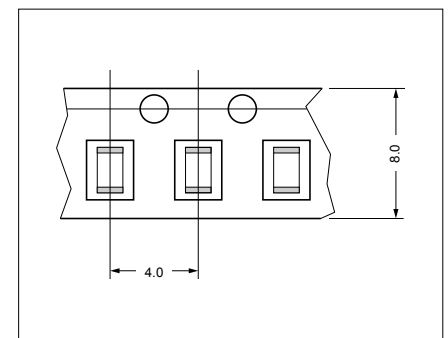

<Electrical Characteristics>

- Wide attenuation range including surrounding circuit.

Test Circuit

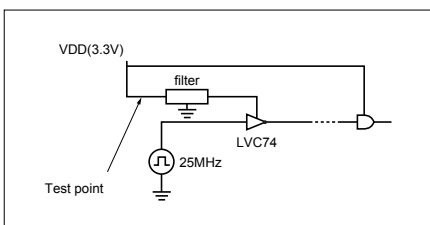

Attenuation Effect of Power Supply Noise

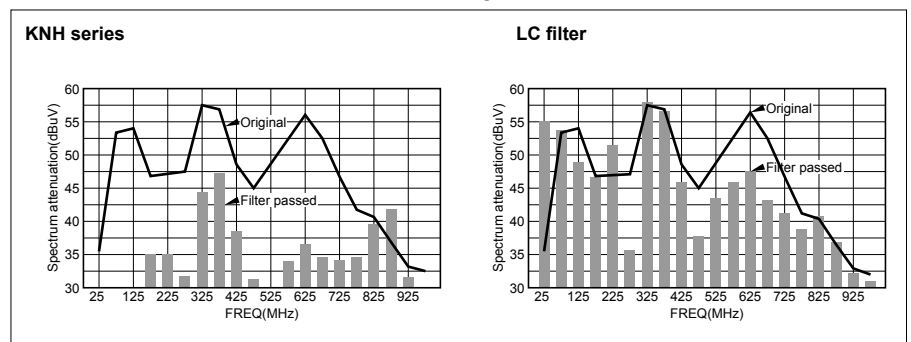

THE NEW VALUE FRONTIER



Timing Devices

Ceramic Resonators

SAW Resonators

Crystal Units

Crystal Oscillators

Voltage Controlled Oscillators

Temperature Compensated Crystal Oscillators (TCXO)

High Precision Oscillators



Products		Dimensions (mm)			Applications					Frequency Range (MHz)					Conditions of Use				Lead-free Status	RoHS Compliant
		L	W	T	Digital Electronics OA, PC Peripherals Amusement	Car Electronics ITS Car Audio Car Navigation	Car Electronics (ECU, Air Bag, ABS, TPMS etc.)	Mobile Comm. Wireless LAN Dedicated Short Range Comm. (DSRC)	Industrial Use (Broadcast, Medical, Base Station etc.)	1	10	50	100	300 ~ 400	Solder			Washable	A: Lead-free Products B: Products with Lead-free Terminations C: Non Lead-free	
										Manual	Reflow	Flow								
Ceramic Resonators	PRTC	2.5	2.0	0.8 max.	○	○		○			25	60			Yes	Yes	No	No	B	Yes
	SSR-B	3.2	2.1	1.5	○	○		○			16	60			Yes	Yes	No	No	B	Yes
	PBRC-G/H	7.4	3.4	2.0 max.	○	○			○		2	20			Yes	Yes	No	Yes	B	Yes
	PBRC-L/M	4.5	2.0	1.2 max.	○	○			○		3.68	20			Yes	Yes	No	Yes	B	Yes
	PRQC	3.2	1.3	1.3	○	○			○		8	20			Yes	Yes	No	Yes	B	Yes
	PBRV-H	7.4	3.4	2.0 max.	○	○			○		4	20			Yes	Yes	No	Yes	B	Yes
	PBRV-M	4.5	2.0	1.2 max.	○	○			○		4	20			Yes	Yes	No	Yes	B	Yes
PPQV	3.2	1.3	1.3	○	○			○		8	20			Yes	Yes	No	Yes	B	Yes	
SAW Resonators	PARM	3.0	3.0	1.5 max.	○	○		○	○					300--479	Yes	Yes	No	Yes	A	Yes
	PARS	5.5	3.8	1.5 max.	○	○		○	○					300--479	Yes	Yes	No	Yes	A	Yes
	PARV	5.5	3.8	1.5 max.	○	○		○	○					300--479	Yes	Yes	No	Yes	A	Yes
Crystal Units	CX2520SB(CX-2520SB)	2.5	2.0	0.45	○	○		○			13.56	60			Yes	Yes	No	Yes	A	Yes
	CX3225SB(CX-101F)	3.2	2.5	0.6 max.	○	○		○			12	54			Yes	Yes	No	Yes	A	Yes
	CX4025SB(CX-4025S)	4.0	2.5	0.75	○	○		○			12	40			Yes	Yes	No	Yes	A	Yes
	CX5032SB(CX-96F)	4.9	3.1	0.7	○	○		○			9.84375	120			Yes	Yes	No	Yes	A	Yes
	CX5032GB(CX-53F)	5.0	3.2	1.0	○	○					9.84375	54			Yes	Yes	No	Yes	B	Yes
	CX8045JA(CX-17F)	8.0	4.5	1.9	○	○		○			8	30			Yes	Yes	No	Yes	B	Yes
	CX8045GB(CX-8045G)	8.0	4.5	1.8	○	○					7.2	48			Yes	Yes	No	Yes	B	Yes
	CX5032GA(CX-53G)	5.0	3.2	1.3	○	○		○			9.84375	40			Yes	Yes	No	Yes	B	Yes
	CXB855GA(CX-5FW)	11.8	5.5	2.5	○	○		○			3.5	20			Yes	Yes	No	Yes	B	Yes
	CXB855GB(CX-5FD)	11.8	5.5	1.8	○	○		○			3.5	60			Yes	Yes	No	Yes	B	Yes
	CXF49FFA(CX-49F)	11.4	5.0	5	○	○		○			3.2	20			Yes	Yes	No	Yes	A	Yes
	CXZ49GFB(CX-49G)	12.3	4.8	4.5 max.	○	○		○			3.2	60			Yes	Yes	No	Yes	A	Yes
	CXZ49CPA(CX-49L)	11.05	4.65	5.08 max.	○	○		○			3.2	20			Yes	Yes	No	Yes	C	No
	CXH49SFB(HC-49/U-S)	11.0	5.0	3.5 max.	○	○		○			3.2	60			Yes	No	Yes	Yes	A	Yes
	CXH49SFA(HC-49/U-S)(Automotive)	11.0	5.0	3.5 max.	○	○		○			3.2	20			Yes	No	Yes	Yes	A	Yes
Oscillators	KC2520A-C1/C2/C3	2.5	2.0	0.8	○	○		○			2	50			Yes	Yes	No	No	A	Yes
	KC3225A-C2/C3(K25-2C/3C)	3.2	2.5	1.0 max.	○	○		○			1	125			Yes	Yes	No	Yes	A	Yes
	KC5032C-C1(K30-1C)	5.0	3.2	1.2 max.	○	○		○			1.8	39.99			Yes	Yes	No	Yes	A	Yes
	KC5032C-C2(K30-2C)	5.0	3.2	1.2 max.	○	○		○			1.8	125			Yes	Yes	No	Yes	A	Yes
	KC5032C-C3(K30-3C)	5.0	3.2	1.2 max.	○	○		○			1.8	160			Yes	Yes	No	Yes	A	Yes
	KC5032C-C3(K30-3C Heavy Load Type)	5.0	3.2	1.2 max.	○	○		○			1.8	14	32		Yes	Yes	No	Yes	A	Yes
	KC5032C-C5(K30-HC)	5.0	3.2	1.2 max.	○	○		○			1.8	50			Yes	Yes	No	Yes	A	Yes
	KC5032P-P2	5.0	3.2	1.2 max.	○	○		○				75	170		Yes	Yes	No	Yes	A	Yes
	KC5032P-P3	5.0	3.2	1.2 max.	○	○		○				75	190		Yes	Yes	No	Yes	A	Yes
	KC5032D(FXO-61F2)	5.0	3.2	1.2 max.	○	○		○			1.8	50			Yes	Yes	No	No	A	Yes
	KC5032D(FXO-64F2)	5.0	3.2	1.2 max.	○	○		○			1.8	50			Yes	Yes	No	No	A	Yes
	KC5032H(MFO-208F)	5.0	3.2	1.35	○	○		○	○		1.5	50			TBA	Yes	No	No	A	Yes
	KC7050A-C1(K53-1C)	7.0	5.0	1.8 max.	○	○		○			1.8	39.99			Yes	Yes	No	Yes	A	Yes
	KC7050A-C2(K53-2C)	7.0	5.0	1.8 max.	○	○		○			1.8	125			Yes	Yes	No	Yes	A	Yes
	KC7050A-C3(K53-3C)	7.0	5.0	1.8 max.	○	○		○			1.8	160			Yes	Yes	No	Yes	A	Yes
	KC7050A-C5(K53-HC)	7.0	5.0	1.8 max.	○	○		○			1.8	50			Yes	Yes	No	Yes	A	Yes
	KC7050B(FXO-31F)	7.0	5.0	1.8	○	○		○			1.8	50			Yes	Yes	No	No	A	Yes
	KC7050B(FXO-37F,N)	7.0	5.0	1.8	○	○		○			1.8	50			Yes	Yes	No	No	A	Yes
	KC7050B(FXO-34F)	7.0	5.0	1.8	○	○		○			1.8	40			Yes	Yes	No	No	A	Yes
	KC7050H-C3(K50H-3C)	7.0	5.0	1.8 max.	○	○		○				50	170		Yes	Yes	No	Yes	A	Yes
	KC5032P-L2/L3	5.0	3.2	1.2 max.	○	○		○				75	170		Yes	Yes	No	Yes	A	Yes
	KC7050P-P2	7.0	5.0	1.8 max.	○	○		○				75	170		Yes	Yes	No	Yes	A	Yes
	KC7050P-P3	7.0	5.0	1.8 max.	○	○		○				75	190		Yes	Yes	No	Yes	A	Yes
	KC7050P-L2/L3	7.0	5.0	1.8 max.	○	○		○				75	170		Yes	Yes	No	Yes	A	Yes
	KC7050S-C1(FSO-2B)	7.0	5.0	2.0 max.	○	○		○				100	170		Yes	Yes	No	Yes*	A	Yes
	KC7050S-C2(FSO-2C)	7.0	5.0	2.0 max.	○	○		○				100	200		Yes	Yes	No	Yes*	A	Yes
	KC7050S-C3(FSO-2D)	7.0	5.0	2.0 max.	○	○		○				100	200		Yes	Yes	No	Yes*	A	Yes
	KCJXO(JXO)	11.0	5.0	3.6 max.	○	○		○			1	70			Yes	Yes	Yes	No	A	Yes
	KCEX03(EXO-3)	12.8	7.0	5.08 max.	○	○		○				11.0592	24.576		Yes	No	Yes	No	A	Yes
	KC7050S-P2/P3(FSO-1C, FSO-1D)	7.0	5.0	2.0 max.	○	○		○				50	700		Yes	Yes	No	Yes*	A	Yes
	KV5032A(VC-FXO-65F)	5.0	3.2	1.2 max.	○	○		○				8	40		Yes	Yes	No	No	A	Yes
	KV7050A(VC-FXO-35F)	7.0	5.0	1.8	○	○		○				8	40		Yes	Yes	No	No	A	Yes
	KV7050L(VCXO-7050/7050L)	7.0	5.0	1.8	○	○		○				7.2	50		Yes	Yes	No	No	A	Yes
	KV7050W-P3(K50V-3P)	7.0	5.0	1.8	○	○		○					155.52		Yes	Yes	No	Yes	A	Yes
	KV7050S-P3(VC-FSO-1D)	7.0	5.0	2.0 max.	○	○		○					600--700		Yes	Yes	No	Yes*	A	Yes
	KT2520Y	2.5	2.0	0.9 max.	○	○		○				12.6	40		TBA	Yes	No	No	A	Yes
	KT33225(KT21)	3.2	2.5	1.0 max.	○	○		○				12.6	38.4		TBA	Yes	No	No	A	Yes
	KT5032(KT18B, VC-TCXO-208Cx)	5.0	3.2	1.5 max.	○	○		○				13	26		TBA	Yes	No	No	A	Yes
	(VC-)DTCXO-12A	30.0	30.0	10.0 max.	○	○		○			1	32			Yes	No	TBA	No	C	No
	(VC-)DTCXO-13A	40.0	40.0	10.0 max.	○	○		○				30	320		Yes	No	TBA	No	C	No
(VC-)DTCXO-15A	14.0	11.5	8.0	○	○		○				10	40		Yes	No	TBA	No	B	No	
OCVCXO-120A	36.1	27.2	19.5 max.	○	○		○				10			Yes	No	TBA	No	C	No	
MCXO-094B	480	450	99	○	○		○				10									

*No ultrasonic washing

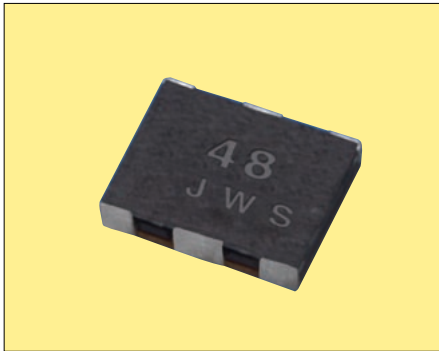

RoHS Compliant

Ultra-miniature chip resonator with 0.8mm maximum height
 Best suited for compact and low profile electronic devices

Features

- Ultra-miniature (2.5×2.0×0.8mm) SMD type
- High precision type is available for full speed USB

Applications

- CD-R/W
- HDD
- DVD-ROM
- MD
- Printer
- Cellular (CDMA/PCS)
- Portable Electronic Equipment
- Memory Card
- USB

How to Order

PRTC 25.00 T R 50 10 W 000
 ① ② ③ ④ ⑤ ⑥ ⑦ ⑧

- ① Series
- ② Oscillating Frequency (MHz)
- ③ Oscillating Mode
- ④ Packaging : Tape & Reel
4000pcs./Reel
- ⑤ Initial Frequency Tolerance (0.5%)
- ⑥ Load Capacitance
- ⑦ Operating Temperature (-20°C to 80°C)
- ⑧ Unique Code

Notice

- Non Washable

Dimensions

(Unit : mm)

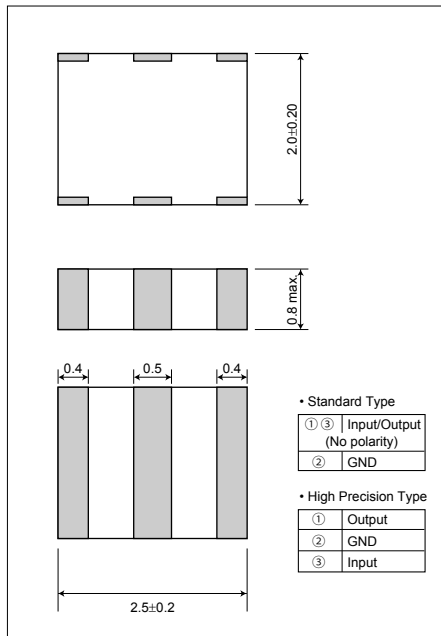

Test Circuit

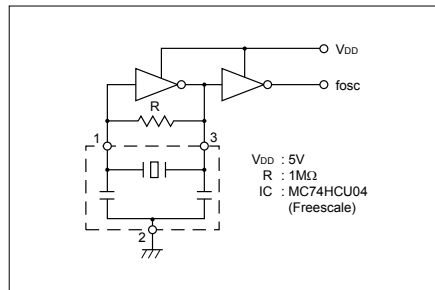

Specifications

• Standard Type

Frequency Range	Frequency Tolerance (25°C)	Temperature Stability (-20 to 80°C)	IC	Standard Frequency (MHz)
25.0 to 60.0MHz	±0.5%	±0.2%	MC74HCU04 (Freescale)	25.0, 30.0, 33.86, 40.0

Please contact your local sales office for IC matching.

• High Precision Type

Frequency Range	Frequency Tolerance (25°C)	Temperature Stability (-20 to 70°C)	Aging (10 years)	IC	Standard Frequency (MHz)
25.0 to 60.0MHz	±0.16%	±0.08%	±0.01%	MC74HCU04 (Freescale)	48.0

Recommended Land Pattern (Unit : mm)

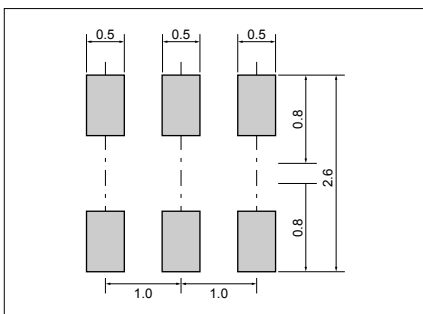

Recommended Reflow Profile

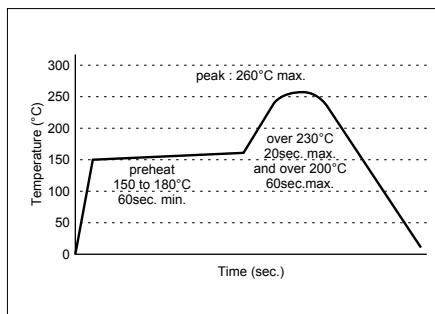

Packaging : Taping

(Unit : mm)

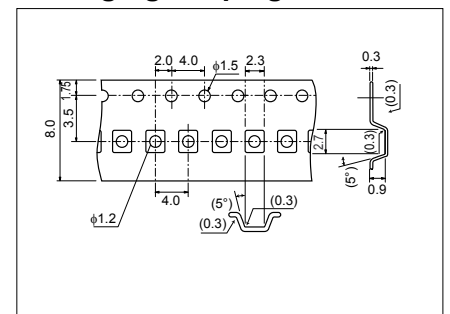



RoHS Compliant

Features

- Miniature size (3.2×2.1×1.5 mm)
- Wide frequency range
- High precision type is available for full speed USB

Applications

- CD-ROM
- HDD
- DVD-ROM
- MD
- Printer
- Cellular (CDMA/PCS)
- Portable Electronic Equipment
- USB

How to Order

SSR 33.86 B R
① ② ③ ④

- ① Series
- ② Oscillating Frequency (MHz)
- ③ Type B: 3rd-Overtone Mode Built-in Capacitor
F: Fundamental Mode Built-in Capacitor
- ④ Packaging : Tape & Reel
2000pcs./Reel

Notice

- Non Washable
- Operating Temperature -20°C to +80°C

Dimensions

(Unit : mm)

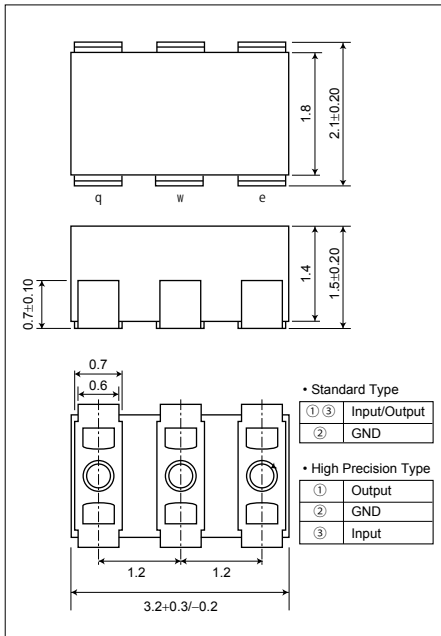

Test Circuit

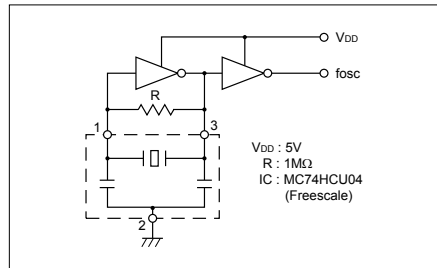

Specifications

• Standard Type

	Frequency Range	Frequency Tolerance (25°C)	Temperature Stability (-20 to 80°C)	IC	Main Frequency (MHz)
B	16.0 to 60.0MHz (3rd-overtone)	±0.5%	±0.3%	MC74HCU04 (Freescale)	16.93, 20.0, 27.0, 33.86, 50.8
F	16.0 to 20.0MHz (Fundamental)				16.93

Please contact your local AVX office for IC matching.

• High Precision Type

	Frequency Range	Frequency Tolerance (25°C)	Temperature Stability (-20 to 70°C)	Aging (10 years)	IC	Main Frequency (MHz)
B	16.0 to 60.0MHz (3rd-overtone)	±0.18% (Option ±0.08%)	±0.06%	±0.01%	MC74HCU04 (Freescale)	48.0

Recommended Land Pattern

(Unit : mm)

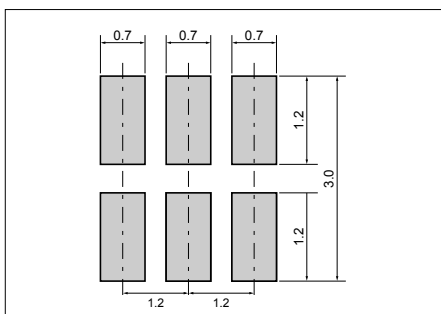

Recommended Reflow Profile

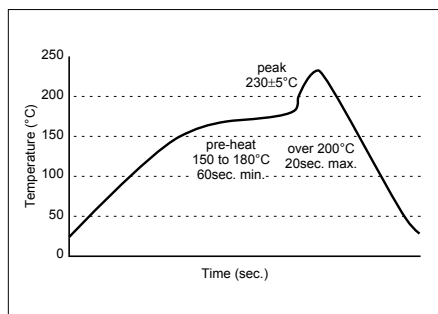

Packaging : Taping

(Unit : mm)

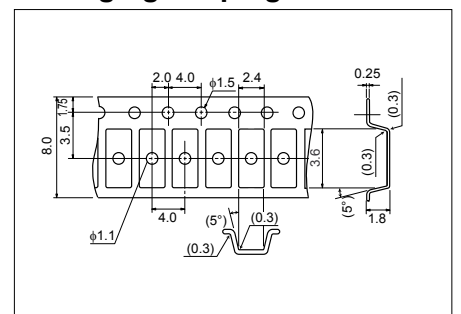



RoHS Compliant

Features

- High reliability, high temperature withstanding ceramic case
- Rectangular shape allows easy pick and placement
- Small & low profile
- Reflow solderable
- Excellent solderability (Nickel barrier+Au flash terminations)

How to Order

PBRC 15.00 G R 50 Y 000
 ① ② ③ ④ ⑤ ⑥ ⑦

- ① Series
- ② Frequency (MHz)
- ③ Type (G,L)
- ④ Packing _ Bulk (Null)
 R Reel (G: 2k/reel, L: 3k/reel)
- ⑤ Frequency Tolerance at 25°C

10	±0.1%	20	±0.2%
30	±0.3%	40	±0.4%
50	±0.5%	70	±0.7%

- ⑥ Operating Temperature

X	-40°C to 85°C	Y	-40°C to 125°C
Z	-40°C to 150°C		

- ⑦ Unique Code

Specifications

Series	Frequency Range(MHz)	Frequency Tolerance(25°C)	Temperature Stability
PBRC-G	2.00 to 8.00	±0.5% (op. ±0.3%)	±0.5% (-40 to 85°C)
	8.01 to 20.0	±0.7% (op. ±0.5%)	±0.1% (-40 to 85°C)
PBRC-L	4.00 to 8.00	±0.5% (op. ±0.3%)	±0.5% (-40 to 85°C)
	8.01 to 20.0	±0.7% (op. ±0.5%)	±0.1% (-40 to 85°C)

* Aging for 10 years is within ±0.3% from the initial frequency at 25°C.

Test Circuit

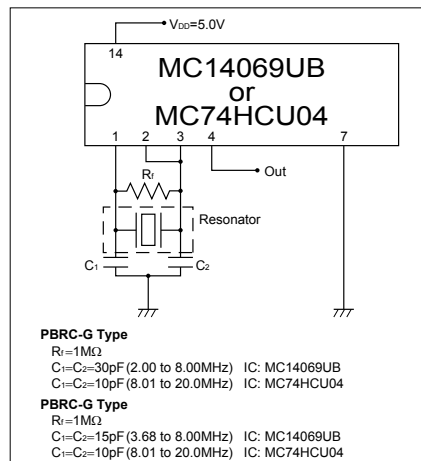

Note)

- Values of C1, C2 and Rf are evaluated with IC, MC14069UB, and evaluation of circuit is necessary when using other IC's.
- IC circuit matching may be referenced with
 1) IC data books
 2) List of Recommended circuits in Kyocera website.
- Please contact IC manufacturer or Kyocera when there are difficulties in finding recommended circuits.

Dimensions

(Unit : mm)

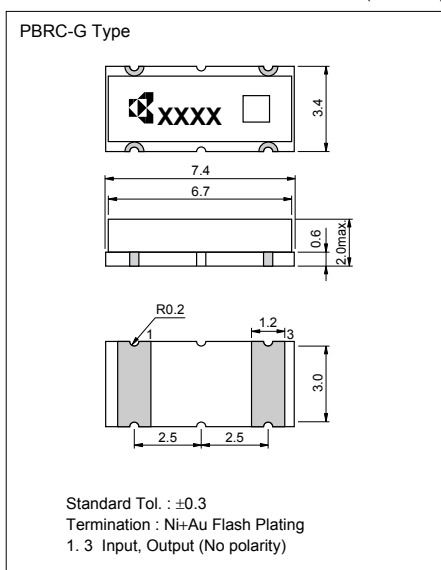

(Unit : mm)

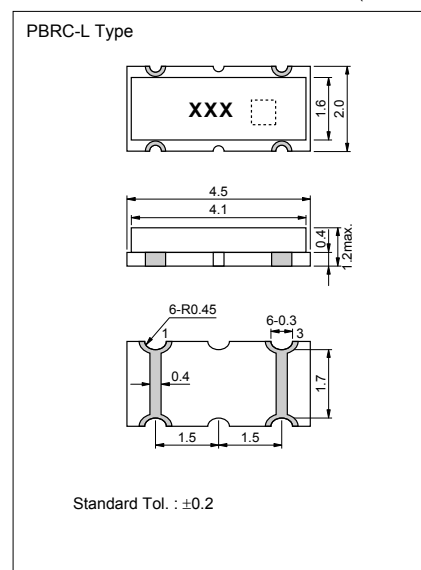

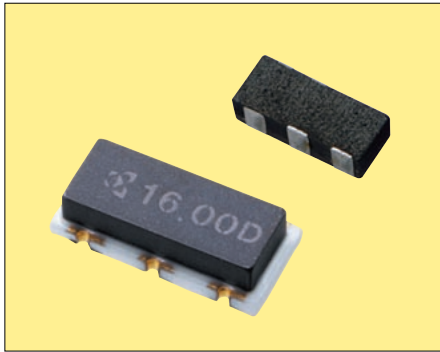

RoHS Compliant

Features

- High reliability, high temperature withstanding ceramic case
- Rectangular shape allows easy pick and placement
- Small & low profile
- Reflow solderable
- Excellent solderability (Nickel barrier+Au flash terminations)

How to Order (PBRC-H,PBRC-M)

PBRC 15.00 H R 50 Y 000
① ② ③ ④ ⑤ ⑥ ⑦

- ① Series
- ② Frequency (MHz)
- ③ Type (H,M)
- ④ Packing _ Bulk (Null) R Reel (H: 2k/reel, M: 3k/reel)
- ⑤ Frequency Tolerance at 25°C

10	±0.1%	20	±0.2%
30	±0.3%	40	±0.4%
50	±0.5%	70	±0.7%

- ⑥ Operating Temperature

X	-40°C to 85°C	Y	-40°C to 125°C
Z	-40°C to 150°C		

- ⑦ Unique Code

How to Order (PRQC)

PRQC 8.00 S R 50 10 X 000
① ② ③ ④ ⑤ ⑥ ⑦ ⑧

- ① Series
- ② Frequency (MHz)
- ③ Type (S)
- ④ Packing _ Bulk (Null) R Reel (3k/reel)
- ⑤ Frequency Tolerance at 25°C

10	±0.1%	20	±0.2%
30	±0.3%	40	±0.4%
50	±0.5%	70	±0.7%

- ⑥ Built-in Capacitance 10pF : 10

- ⑦ Operating Temperature

W	-20°C to 80°C	Y	-40°C to 125°C
X	-40°C to 85°C	Z	-40°C to 150°C

- ⑧ Unique Code

Specifications

Series	Frequency Range(MHz)	Frequency Tolerance(25°C)	Temperature Stability
PBRC-H	2.00 to 8.00	±0.5% (op. ±0.3%)	±0.5% (-40 to 85°C)
	8.01 to 20.0	±0.7% (op. ±0.5%)	±0.1% (-40 to 85°C)
PBRC-M	4.00 to 8.00	±0.5% (op. ±0.3%)	±0.5% (-40 to 85°C)
	8.01 to 20.0	±0.7% (op. ±0.5%)	±0.1% (-40 to 85°C)
PRQC	8.00 to 20.0	±0.5% (op. ±0.3%)	±0.5% (-40 to 85°C)

* Aging for 10 years is within ±0.3% from the initial frequency at 25°C.

Test Circuit

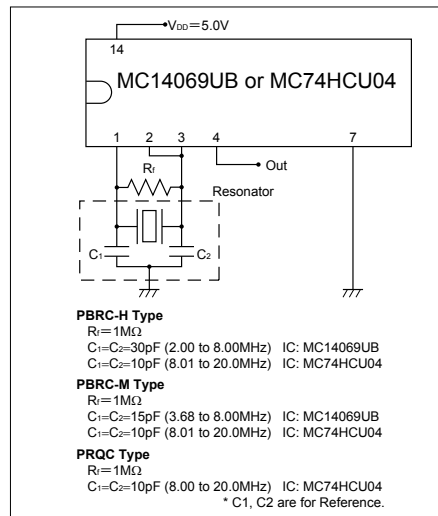

Note)

- This product includes built-in capacitors, but values may not be the most appropriate depending on IC's.
- Evaluation of circuit with IC is necessary. IC circuit matching may be referenced with
 - 1) IC data books
 - 2) List of Recommended circuits in Kyocera website.
- Please contact IC manufacturer or Kyocera when there are difficulties in finding recommended circuits.

Dimensions

(Unit : mm)

(Unit : mm)

(Unit : mm)

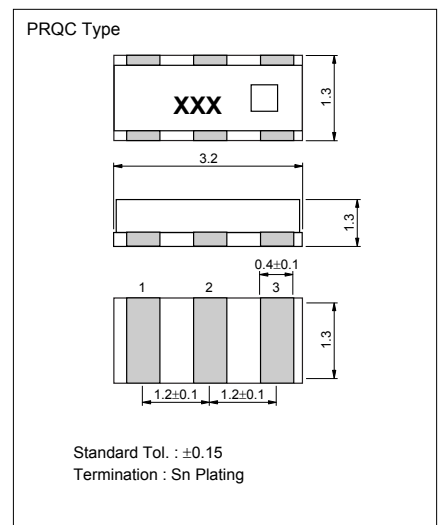
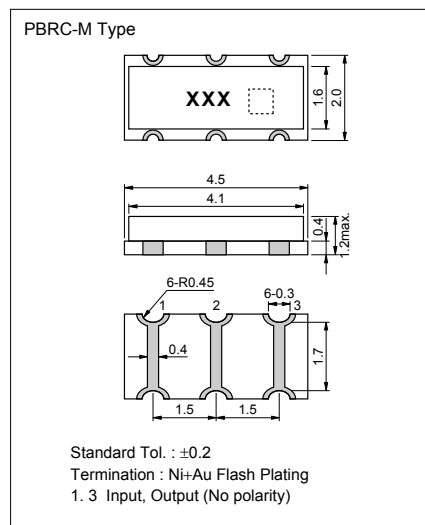
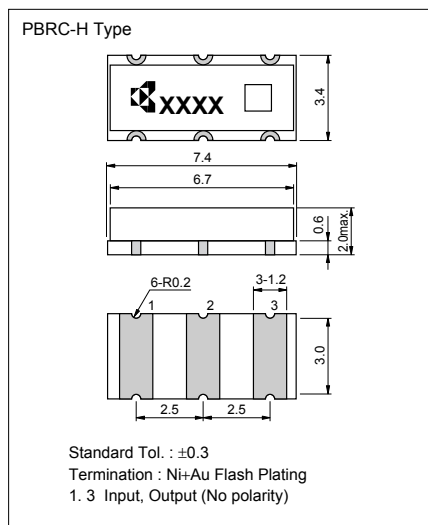

#	Pin #
1	Input
2	Ground
3	Output

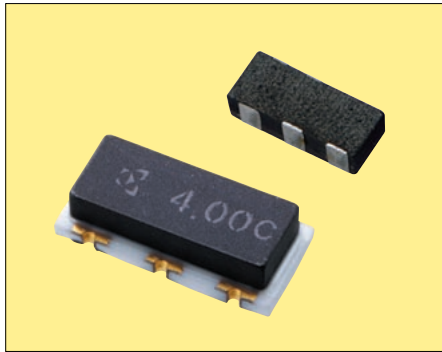

RoHS Compliant

Features

- Miniature & low profile
- Rectangular shape allows easy pick and placement
- Component cost and space saving
- High density mounting possible
- Reflow solderable & washable
- High reliability, high temperature operating with ceramic case

Applications

- Automotive
- ABS
- ECU
- Air-Bag System

How to Order (PBRV-H,PBRV-M)

PBRV 15.00 H R 50 Y 000
① ② ③ ④ ⑤ ⑥ ⑦

- ① Series (PBRV: Automotive)
- ② Frequency (MHz)
- ③ Type (H,M)
- ④ Packing _ Bulk (Null) R Reel (H: 2k/reel, M: 3k/reel)
- ⑤ Frequency Tolerance at 25°C

10	±0.1%	20	±0.2%
30	±0.3%	40	±0.4%
50	±0.5%	70	±0.7%

- ⑥ Operating Temperature

X	-40°C to 85°C	Y	-40°C to 125°C
Z	-40°C to 150°C		

- ⑦ Unique Code

How to Order (PRQV)

PRQV 8.00 S R 50 10 Y 000
① ② ③ ④ ⑤ ⑥ ⑦ ⑧

- ① Series (PRQV: Automotive)
- ② Frequency (MHz)
- ③ Type (S)
- ④ Packing _ Bulk (Null) R Reel (3k/reel)

- ⑤ Frequency Tolerance at 25°C

10	±0.1%	20	±0.2%
30	±0.3%	40	±0.4%
50	±0.5%	70	±0.7%

- ⑥ Built-in Capacitance 10pF : 10

- ⑦ Operating Temperature

X	-40°C to 85°C	Y	-40°C to 125°C
Z	-40°C to 150°C		

- ⑧ Unique Code

Specifications

Series	Frequency Range(MHz)	Frequency Tolerance(25°C)	Temperature Stability
PBRV-H	4.00 to 8.00	±0.5% (op. ±0.3%)	Y: ±0.5%(-40 to +125°C) Z: ±0.5%(-40 to +150°C)
PBRV-M	8.01 to 20.00	±0.7% (op. ±0.5%)	Y: ±0.1%(-40 to +125°C) Z: ±0.2%(-40 to +150°C)
PRQV	8.00 to 20.00	±0.5% (op. ±0.3%)	Y: ±0.5%(-40 to +125°C) Z: ±0.5%(-40 to +150°C)

* Aging for 10 years is within ±0.3% from the initial frequency at 25°C.

* Please contact us for products without built-in capacitors.

Note)

- This product includes built-in capacitors, but values may not be the most appropriate depending on IC's.
- Evaluation of circuit with IC is necessary. IC circuit matching may be referenced with
 - 1) IC data books
 - 2) List of Recommended circuits in Kyocera website.
- Please contact IC manufacturer or Kyocera when there are difficulties in finding recommended circuits.

Test Circuit

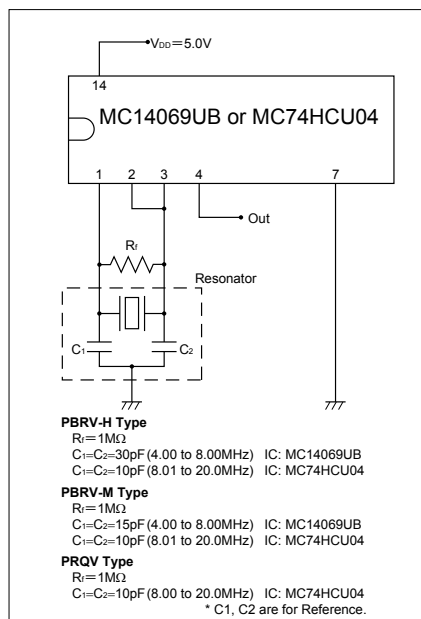

Dimensions

(Unit : mm)

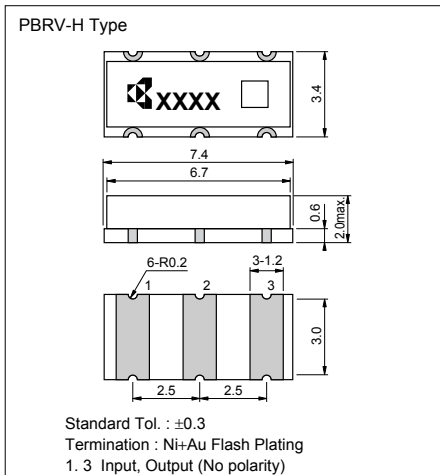

#	Pin #
1	Input
2	Ground
3	Output

(Unit : mm)

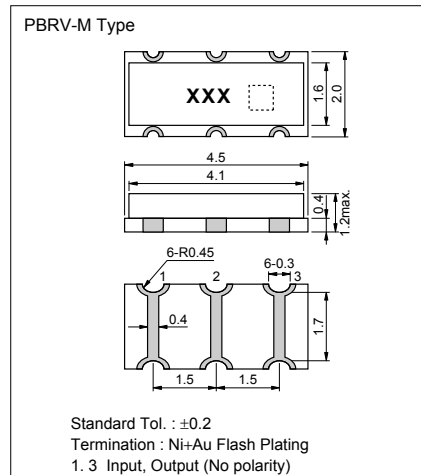

(Unit : mm)

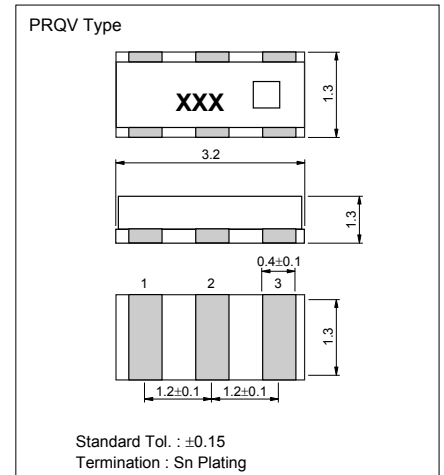

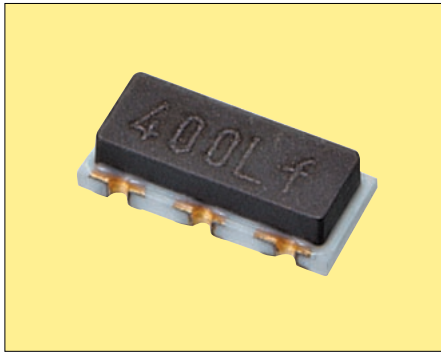

RoHS Compliant

Features

- Improved frequency tolerance for CANBUS application of automotive

How to Order (PBRV)

PBRV 15.00 H R 10 Y 000
① ② ③ ④ ⑤ ⑥ ⑦

- Series (PBRV: Automotive)
- Frequency (MHz)
- Type (H,M)
- Packing _ Bulk (Null)
R Reel (H: 2k/reel, M: 3k/reel)
- Frequency Tolerance at 25°C
10 ±0.1%
- Operating Temperature
X -40°C to 85°C **Y** -40°C to 125°C
Z -40°C to 150°C
- Unique Code

How to Order (PRQV)

PRQV 8.00 S R 10 10 Y 000
① ② ③ ④ ⑤ ⑥ ⑦ ⑧

- Series (PRQV: Automotive)
- Frequency (MHz)
- Type (S)
- Packing _ Bulk (Null)
R Reel (3k/reel)
- Frequency Tolerance at 25°C
10 ±0.1%
- Built-in Capacitance 10pF : 10
- Operating Temperature
X -40°C to 85°C **Y** -40°C to 125°C
Z -40°C to 150°C
- Unique Code

Specifications

Series	PBRV-HR/MR	PBRV-HR/MR	PRQV-S
Part Number	PBRV-HR/MR 10Y□□□	PBRV-HR/MR 10Y□□□	PRQV-SR□10Y□□□
Operating Temperature Range	-40 to +125°C	-40 to +125°C	-40 to +125°C
Frequency Range	4.0 to 7.9MHz	8.0 to 20.0MHz	8.0 to 20.0MHz
Frequency Tolerance	Initial+Temperature	±0.2%	±0.25%
	Aging	±0.1%	±0.05%
Total Frequency Tolerance	±0.4%	±0.3%	±0.3%

* Please refer to the specification sheet of each product for information including detail dimensions.

* Aging characteristics is specified at 25°C, and for the period of 10 years.

Dimensions

(Unit : mm)

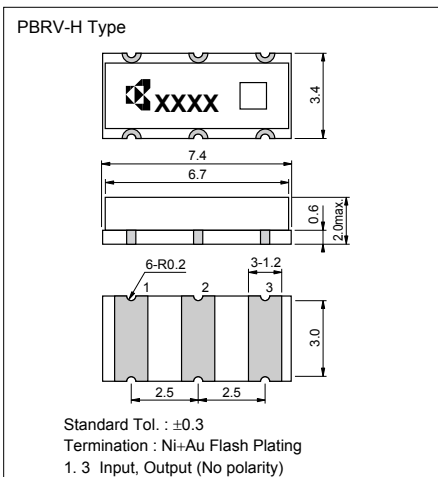

#	Pin #
1	Input
2	Ground
3	Output

(Unit : mm)

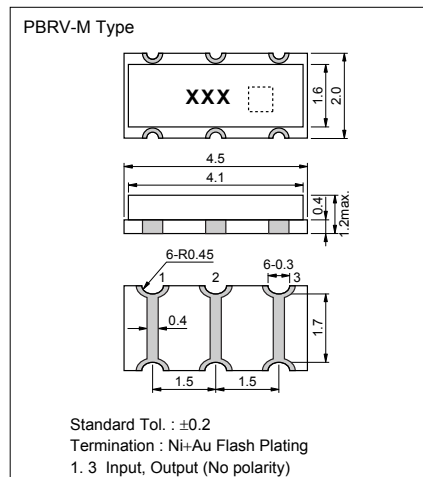

(Unit : mm)

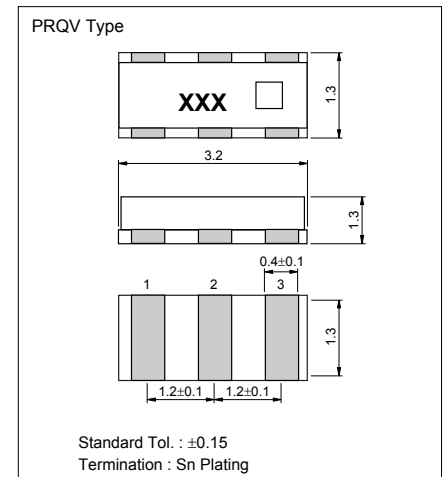



Recommended Land Pattern

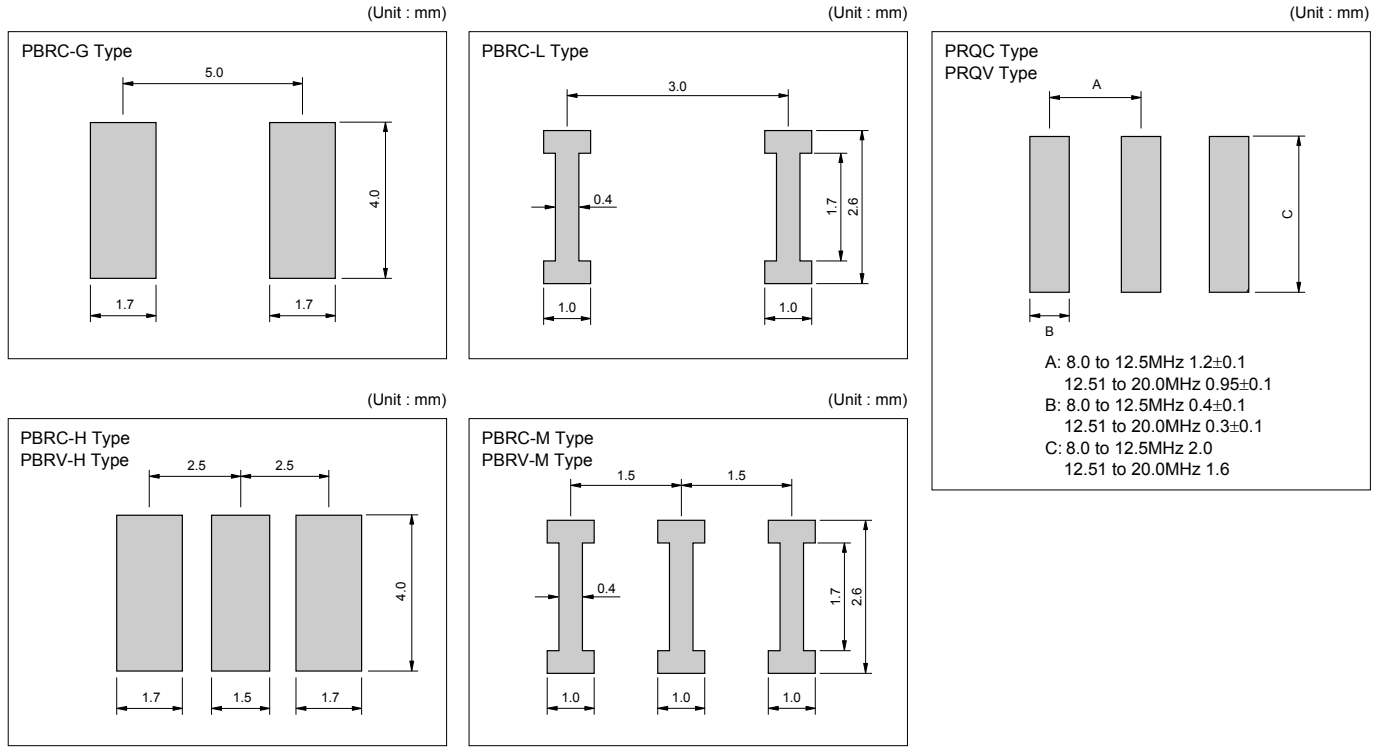

Packaging

Reel

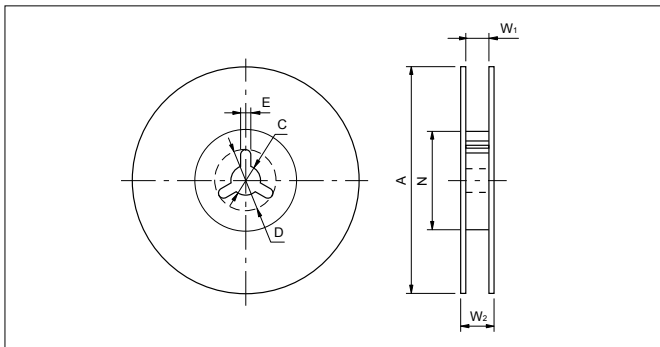

Taping

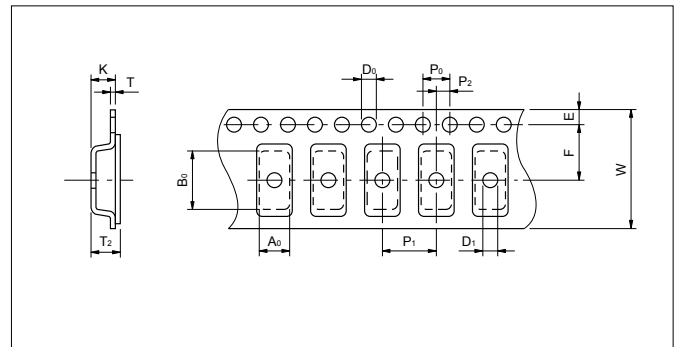

Code	A	N	W ₁	W ₂	C	D	E
7.4×3.4×2.0mm	250±2.0	80±2.0	16.5 ^{+0.1} _{-0.0}	23.6max.	13.0±0.5	21.0±0.8	2.0±0.5
4.5×2.0×1.2mm	180 ⁺⁰ ₋₃	60 ⁺¹ ₋₀	13.0±0.3	15.4±1	13.0±0.2	21.0±0.8	2.0±0.5
3.2×1.3×1.3mm	180±2	60 ⁺¹ ₋₀	9.0 ^{+0.0} _{-1.0}	140min.	13.0±0.2	21.0±0.8	2.0±0.5

Code	A ₀	B ₀	W	F	E	P ₁	P ₂	P ₀	D ₀	D ₁	T	T ₂	K
7.4×3.4×2.0mm	3.80±0.1	7.80±0.1	16.00±0.3	7.50±0.1	1.75±0.1	8.00±0.1	2.0±0.1	4.00±0.1	1.50 ^{-0.1} _{-0.0}	1.50 ^{-0.1} _{-0.0}	0.30±0.05	2.45±0.2	2.40±0.2
4.5×2.0×1.2mm	2.20±0.1	4.70±0.1	12.00±0.2	5.5±0.05	1.75±0.1	4.00±0.1	2.0±0.05	4.00±0.1	1.50 ^{-0.1} _{-0.0}	1.0±0.1	0.30±0.05	1.85max.	1.80max.
3.2×1.3×1.3mm	1.50±0.1	3.40±0.1	8.00±0.2	3.50±0.05	1.75±0.1	4.00±0.1	2.0±0.05	4.00±0.1	1.50 ^{-0.1} _{-0.0}	1.0 ^{+0.2} _{-0.0}	0.25±0.05	1.30max.	0.90±0.1

* 7.4×3.4×2.0mm=PBRC-G, PBRC-H, PBRV-G, PBRV-H 2000pcs./Reel
 4.5×2.0×1.2mm=PBRC-L, PBRC-M, PBRV-L, PBRV-M 3000pcs./Reel
 3.2×1.3×1.3mm=PRQC-S, PRQV-S 3000pcs./Reel



Pb Free

RoHS Compliant

Features

- Frequency range 300 to 480MHz
- 1 port type SMD resonator
- Small size (5.5×3.8mm)
- Low profile (1.5mm max.)
- SMT ceramic package
- High reliability sealing
- Excellent temperature characteristics
- +100ppm to -250ppm (-40°C to 85°C)

Applications

- Keyless Entry Systems
- Garage Openers
- Security Systems

How to Order

PARS 315.00 K 00 R

① ② ③ ④ ⑤

- ① Series
- ② Resonant Frequency (MHz)
- ③ Marking Code
- ④ Frequency Tolerance or Custom Spec.

00	±250kHz	03	±100kHz
01	±200kHz	04	±75kHz
02	±150kHz	11≤	Custom Spec.

- ⑤ Packaging
R : Tape & Reel (2000pcs./Reel)

Dimensions

(Unit : mm)

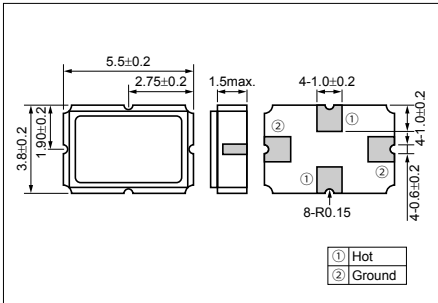

Recommended Land Pattern

(Unit : mm)

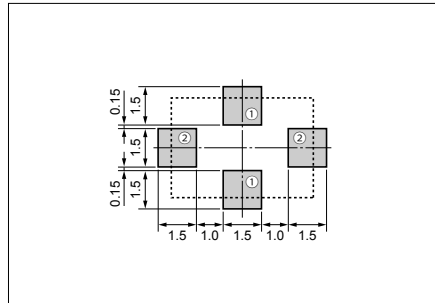

Packaging

(Unit : mm)

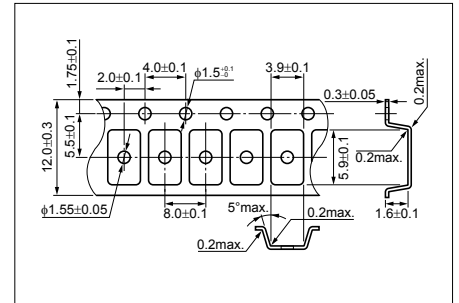

Specifications

Part Number	Resonant Frequency(MHz)	Resonant Loss(dB)	Parallel Capacitance(pF)	Temperature Characteristics (ppm/°C)
PARS303.00N04R	303.000±0.075	2.5 max.	4.0 max.	±8 max.
PARS303.33L04R	303.330±0.075			
PARS303.82M04R	303.825±0.075			
PARS303.87K04R	303.875±0.075			
PARS304.30K04R	304.300±0.075			
PARS304.45L04R	304.450±0.075			
PARS310.00K04R	310.000±0.075		3.2 max.	
PARS314.00K04R	314.000±0.075			
PARS314.50L04R	314.500±0.075			
PARS315.00K04R	315.000±0.075			
PARS320.65K04R	320.650±0.075			
PARS345.00K04R	345.000±0.075			
PARS418.00K04R	418.000±0.075		2.3 max.	
PARS423.22K04R	423.220±0.075			
PARS432.92K04R	432.920±0.075			
PARS433.92K04R	433.920±0.075			
PARS479.50K04R	479.500±0.075			

*Please contact your local sales office for custom frequency.

Recommended Temperature IR Reflow

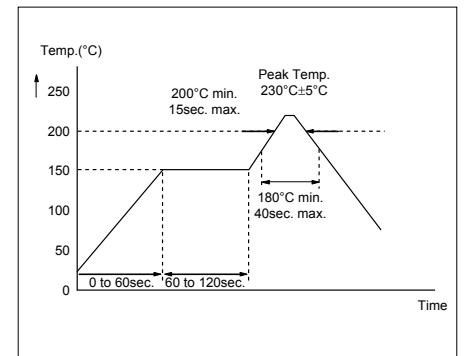



Pb Free

RoHS Compliant

Surface Acoustic Wave Resonator for Remote Keyless Entry System (RKE)

Features

- Ultra-miniature size
- 1 port type SMD resonator
- High reliability
- Excellent temperature characteristics

Applications

- Remote Keyless Entry System (RKE)
- Garage Openers
- Security Systems

How to Order

PARM 315.00 K 04 R

① ② ③ ④ ⑤

- ① Series
- ② Resonant Frequency (MHz)
- ③ Marking Code
- ④ Frequency Tolerance or Custom Spec.

00	$\pm 250\text{kHz}$	03	$\pm 100\text{kHz}$
01	$\pm 200\text{kHz}$	04	$\pm 75\text{kHz}$
02	$\pm 150\text{kHz}$	11	Custom spec.

⑤ Type

Dimensions

(Unit : mm)

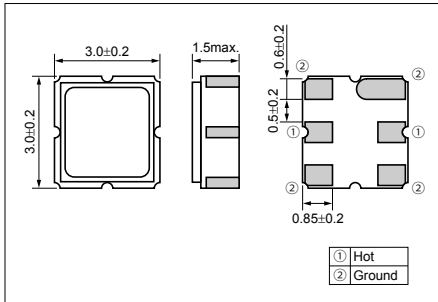

Recommended Land Pattern

(Unit : mm)

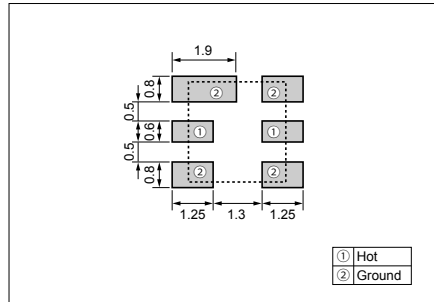

Packaging

(Unit : mm)

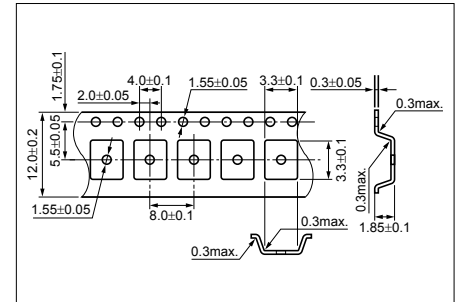

Specifications

Part Number	Resonant Frequency(MHz)	Resonant Loss(dB)	Parallel Capacitance(pF)	Temperature Characteristics(ppm/°C)	Operating Temperature(°C)	Storage Temperature(°C)
PARM315.00K04R	315.000±0.075	2.5 max.	4.0 max.	±8 max.	-40 to 85	-40 to 85
PARM433.92K04R	433.920±0.075					

Recommended Temperature IR Reflow

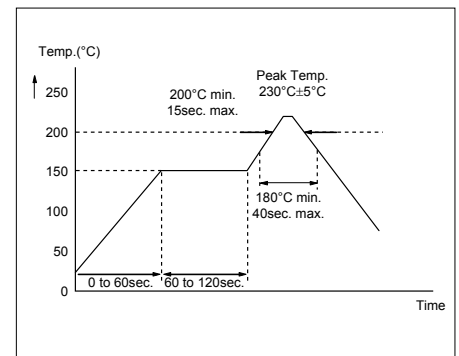



Pb Free

RoHS Compliant

Features

- Crystal unit for audio-visual, office equipment
- Ultra-miniature and low profile (2.5x2.0x0.45mm)
- Ceramic package
- A lead free product
- Reflow compatible

Applications

- Digital Electronics
- Audio-Visual, Office Equipment

How to Order

CX2520SB 27000 D0 P E S ZZ
 ① ② ③ ④ ⑤ ⑥ ⑦

① Code

② Typical Frequencies

Code	Freq.(kHz)	Code	Freq.(kHz)
13560	13560.000	30000	30000.000
16000	16000.000	32000	32000.000
18000	18000.000	33000	33000.000
20000	20000.000	33333	33333.000
24000	24000.000	40000	40000.000
26000	26000.000	48000	48000.000
27000	27000.000	54000	54000.000
27120	27120.000		

*Please inquire about frequencies other than the above.

③ Load Capacitance

D0	8pF
-----------	-----

④ Frequency Stability

P	±50×10 ⁻⁶
----------	----------------------

⑤ Operating Temperature Range

E	-10°C to +70°C
----------	----------------

⑥ Frequency Temperature Stability

S	±50×10 ⁻⁶
----------	----------------------

⑦ Special

ZZ	Custom Specification
-----------	----------------------

Specifications

Items	Symbol	Specification	Units	Remarks
Frequency Range	f _{nom}	13560 to 60000	kHz	
Overtone Order	OT	Fundamental	—	
Frequency Tolerance	f _{tol}	±50	×10 ⁻⁶	@ 25°C
Frequency Temp. Characteristics	f _{tem}	±50	×10 ⁻⁶	ref.@ 25°C Over Operating Temp. Range
Motional Series Resistance	R1	Table 1	ohm	
Level of Drive	DL	Table 2	μW	
Load Capacitance	CL	8	pF	
Operating Temp. Range	T _{use}	-10 to +70	°C	
Storage Temp. Range	T _{stg}	-40 to +85	°C	

* Please inquire about specifications other than the above.

Table1 Motional Series Resistances

Frequency Range	Motional Series Resistance	Units
13560 to 15999kHz	300	ohm
16000 to 19999kHz	150	
20000 to 39999kHz	100	
40000 to 60000kHz	50	

Table2 Level of Drive

Frequency Range	Level of Drive	Units
13560 to 60000kHz	10 (100 max.)	μW

Dimensions

(Unit : mm)

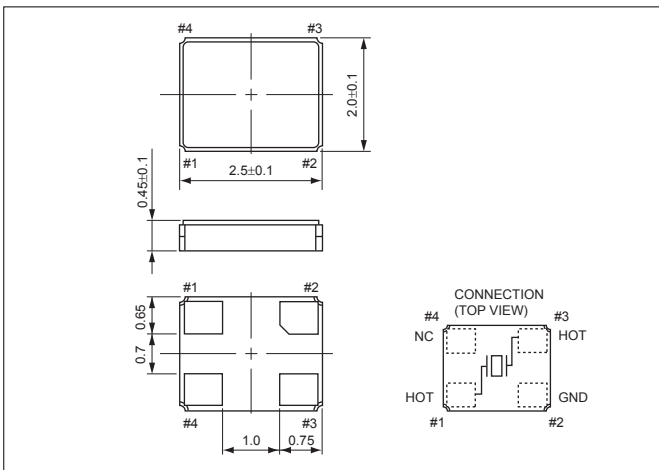

Recommended Land Pattern

(Unit : mm)

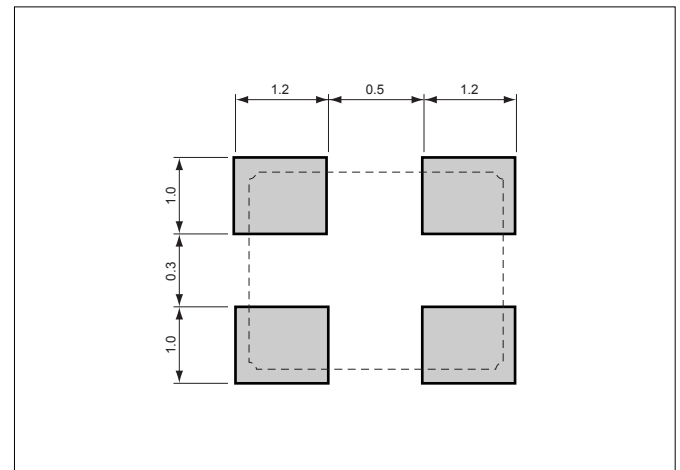

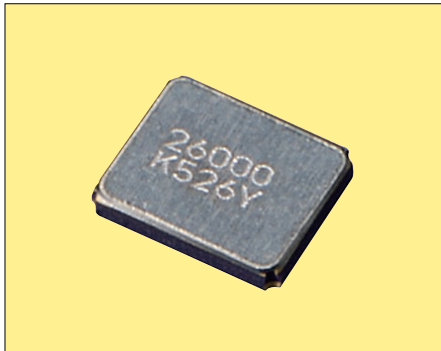

Pb Free

RoHS Compliant

Features

- Reference frequency for telecommunication systems
- Reflow compatible
- Using ceramic package resulting in high reliability
- Small and low profile

Applications

- Mobile Communications, Bluetooth, Wireless LAN

How to Order

CX2520SB 32000 D0 F L J ZZ
 ① ② ③ ④ ⑤ ⑥ ⑦

① Code

② Typical Frequencies

Code	Freq.(kHz)	Code	Freq.(kHz)
13560	13560.000	27120	27120.000
16000	16000.000	32000	32000.000
18000	18000.000	38400	38400.000
19200	19200.000	40000	40000.000
24000	24000.000	44000	44000.000
26000	26000.000		

*Please inquire about frequencies other than the above.

③ Load Capacitance

D0	8pF
-----------	-----

④ Frequency Stability

F	$\pm 10 \times 10^{-6}$
----------	-------------------------

⑤ Operating Temperature Range

L	-30°C to +85°C
----------	----------------

⑥ Frequency Temperature Stability

J	$\pm 15 \times 10^{-6}$
----------	-------------------------

⑦ Special

ZZ	Custom Specification
-----------	----------------------

Specifications

Items	Symbol	Specification	Units	Remarks
Frequency Range	f _{nom}	13560 to 60000	kHz	
Overtone Order	OT	Fundamental	—	
Frequency Tolerance	f _{tol}	±10	×10 ⁻⁶	@ 25°C
Frequency Temp. Characteristics	f _{tem}	±15	×10 ⁻⁶	ref.@ 25°C Over Operating Temp. Range
Motional Series Resistance	R1	Table 1	ohm	
Level of Drive	DL	Table 2	μW	
Load Capacitance	CL	8	pF	
Operating Temp. Range	T _{use}	-30 to +85	°C	
Storage Temp. Range	T _{stg}	-40 to +85	°C	

* Please inquire about specifications other than the above.

Table1 Motional Series Resistances

Frequency Range	Motional Series Resistance	Units
13560 to 15999kHz	300	ohm
16000 to 19999kHz	150	
20000 to 39999kHz	100	
40000 to 60000kHz	50	

Table2 Level of Drive

Frequency Range	Level of Drive	Units
13560 to 60000kHz	10 (100 max.)	μW

Dimensions

(Unit : mm)

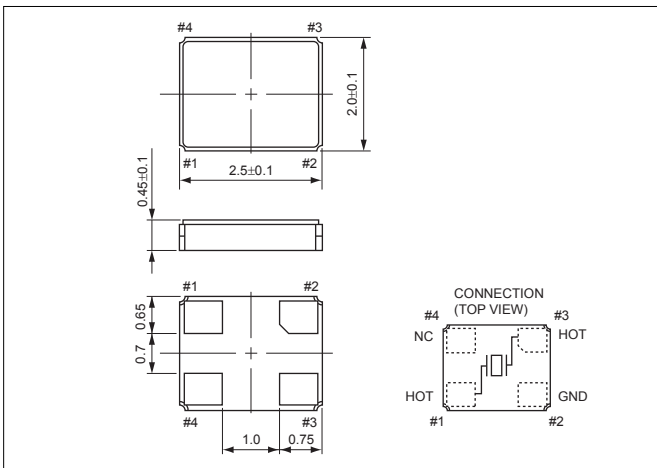

Recommended Land Pattern

(Unit : mm)

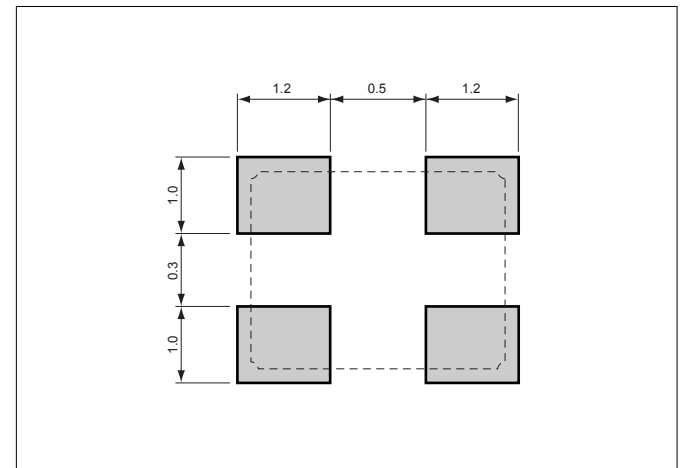



Pb Free

RoHS Compliant

Features

- Crystal unit for audio-visual, office equipment
- Miniature and low profile (3.2x2.5x0.55mm)
- Ceramic package
- A lead free product
- Reflow compatible

Applications

- Digital Electronics
- Audio-Visual, Office Equipment

How to Order

CX3225SB 24000 D0 P E S ZZ
 ① ② ③ ④ ⑤ ⑥ ⑦

① Code

② Typical Frequencies

Code	Freq.(kHz)	Code	Freq.(kHz)
12000	12000.000	25000	25000.000
13560	13560.000	26000	26000.000
14318	14318.180	27000	27000.000
14745	14745.600	27120	27120.000
16000	16000.000	30000	30000.000
18432	18432.000	33000	33000.000
20000	20000.000	33333	33333.000
22579	22579.000	40000	40000.000
24000	24000.000	48000	48000.000
24576	24576.000	54000	54000.000

*Please inquire about frequencies other than the above.

③ Load Capacitance

D0	8pF
-----------	-----

④ Frequency Stability

P	$\pm 50 \times 10^{-6}$
----------	-------------------------

⑤ Operating Temperature Range

E	-10°C to +70°C
----------	----------------

⑥ Frequency Temperature Stability

S	$\pm 50 \times 10^{-6}$
----------	-------------------------

⑦ Special

ZZ	Custom Specification
-----------	----------------------

Specifications

Items	Symbol	Specification	Units	Remarks
Frequency Range	f _{nom}	12000 to 54000	kHz	
Overtone Order	OT	Fundamental	—	
Frequency Tolerance	f _{tol}	±50	×10 ⁻⁶	@ 25°C
Frequency Temp. Characteristics	f _{tem}	±50	×10 ⁻⁶	ref.@ 25°C Over Operating Temp. Range
Motional Series Resistance	R1	Table 1	ohm	
Level of Drive	DL	Table 2	μW	
Load Capacitance	CL	8	pF	
Operating Temp. Range	T _{use}	-10 to +70	°C	
Storage Temp. Range	T _{stg}	-40 to +85	°C	

*Please inquire about specifications other than the above.

Table1 Motional Series Resistances

Frequency Range	Motional Series Resistance	Units
12000 to 13999kHz	300	ohm
14000 to 15999kHz	200	
16000 to 26999kHz	100	
27000 to 54000kHz	50	

Table2 Level of Drive

Frequency Range	Level of Drive	Units
12000 to 54000kHz	10 (100 max.)	μW

Dimensions

(Unit : mm)

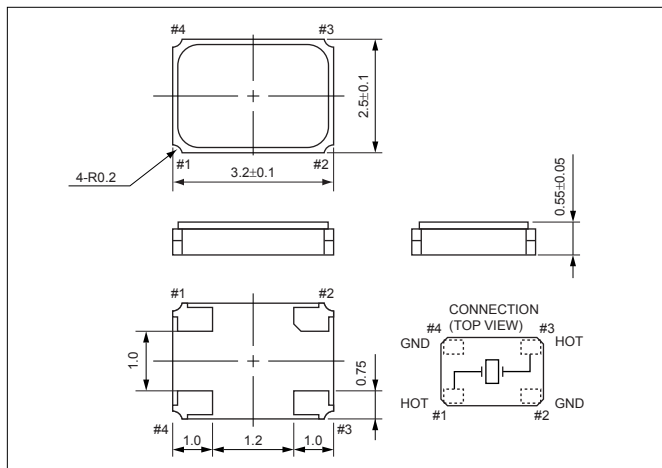

Recommended Land Pattern

(Unit : mm)

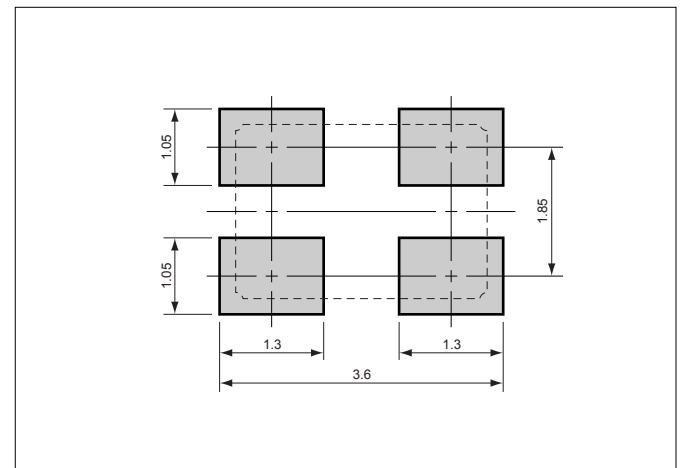



Pb Free

RoHS Compliant

Features

- Reference frequency for telecommunication systems
- Reflow compatible
- Using ceramic package resulting in high reliability
- Small and low profile

Applications

- Mobile Communications, Bluetooth, Wireless LAN

How to Order

CX3225SB 26000 D0 F L J ZZ
 ① ② ③ ④ ⑤ ⑥ ⑦

- ① Code
- ② Typical Frequencies

Code	Freq.(kHz)	Code	Freq.(kHz)
12000	12000.000	20000	20000.000
13000	13000.000	26000	26000.000
13560	13560.000	32000	32000.000
16000	16000.000	38400	38400.000
19200	19200.000	40000	40000.000

*Please inquire about frequencies other than the above.

③ Load Capacitance	D0 8pF
④ Frequency Stability	F ±10×10 ⁻⁶
⑤ Operating Temperature Range	L -30°C to +85°C
⑥ Frequency Temperature Stability	J ±15×10 ⁻⁶
⑦ Special	ZZ Custom Specification

Specifications

Items	Symbol	Specification	Units	Remarks
Frequency Range	f _{nom}	12000 to 54000	kHz	
Overtone Order	OT	Fundamental	—	
Frequency Tolerance	f _{tol}	±10	×10 ⁻⁶	@ 25°C
Frequency Temp. Characteristics	f _{tem}	±15	×10 ⁻⁶	ref.@ 25°C Over Operating Temp. Range
Motional Series Resistance	R1	Table 1	ohm	
Level of Drive	DL	Table 2	μW	
Load Capacitance	CL	8	pF	
Operating Temp. Range	T _{use}	-30 to +85	°C	
Storage Temp. Range	T _{stg}	-40 to +85	°C	

* Please inquire about specifications other than the above.

Table1 Motional Series Resistances

Frequency Range	Motional Series Resistance	Units
12000 to 13999kHz	300	ohm
14000 to 15999kHz	200	
16000 to 26999kHz	100	
27000 to 54000kHz	50	

Table2 Level of Drive

Frequency Range	Level of Drive	Units
12000 to 54000kHz	10 (100 max.)	μW

Dimensions

(Unit : mm)

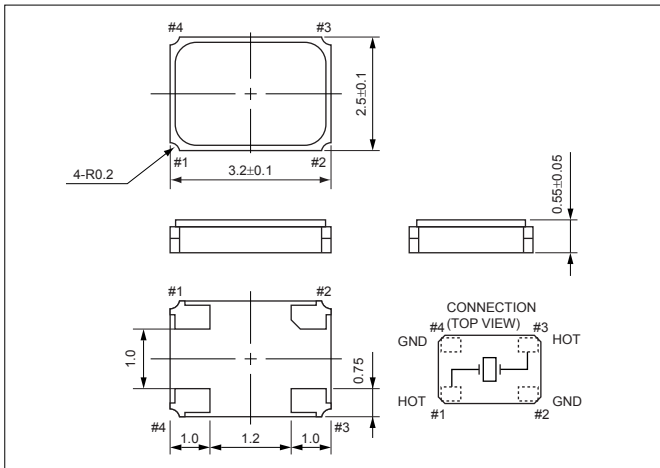

Recommended Land Pattern

(Unit : mm)

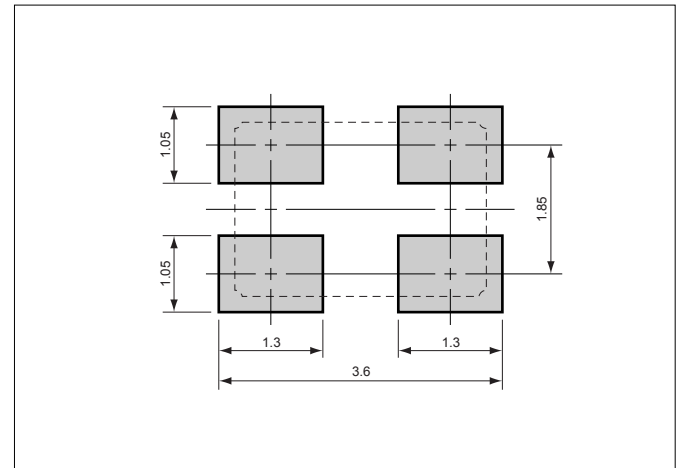

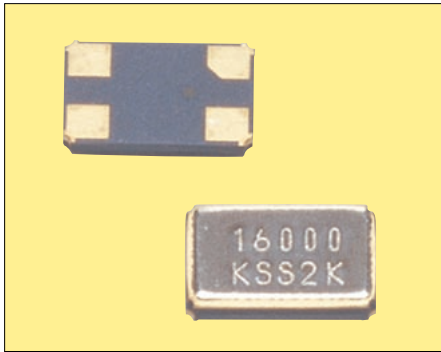

Pb Free

RoHS Compliant

Features

- Reference frequency for telecommunication systems
- Reflow compatible
- Using ceramic package resulting in high reliability
- Small and low profile

Applications

- Mobile Communications, Bluetooth, Wireless LAN

How to Order

CX4025SB 26000 F0 F L J ZZ
 ① ② ③ ④ ⑤ ⑥ ⑦

① Code

② Typical Frequencies

Code	Freq.(kHz)	Code	Freq.(kHz)
12000	12000.000	26000	26000.000
13000	13000.000	32000	32000.000
16000	16000.000	40000	40000.000
20000	20000.000		

*Please inquire about frequencies other than the above.

③ Load Capacitance

F0	10pF
-----------	------

④ Frequency Stability

F	±10×10 ⁻⁶
----------	----------------------

⑤ Operating Temperature Range

L	-30°C to +85°C
----------	----------------

⑥ Frequency Temperature Stability

J	±15×10 ⁻⁶
----------	----------------------

⑦ Special

ZZ	Custom Specification
-----------	----------------------

Specifications

Items	Symbol	Specification	Units	Remarks
Frequency Range	f _{nom}	12000 to 40000	kHz	
Overtone Order	OT	Fundamental	—	
Frequency Tolerance	f _{tol}	±10	×10 ⁻⁶	@ 25°C
Frequency Temp. Characteristics	f _{tem}	±15	×10 ⁻⁶	ref.@ 25°C Over Operating Temp. Range
Motional Series Resistance	R1	Table 1	ohm	
Level of Drive	DL	Table 2	μW	
Load Capacitance	CL	10	pF	
Operating Temp. Range	T _{use}	-30 to +85	°C	
Storage Temp. Range	T _{stg}	-40 to +85	°C	

* Please inquire about specifications other than the above.

Table1 Motional Series Resistances

Frequency Range	Motional Series Resistance	Units
12000 to 19999kHz	80	ohm
20000 to 40000kHz	50	

Table2 Level of Drive

Frequency Range	Level of Drive	Units
12000 to 40000kHz	10 (100 max.)	μW

Dimensions

(Unit : mm)

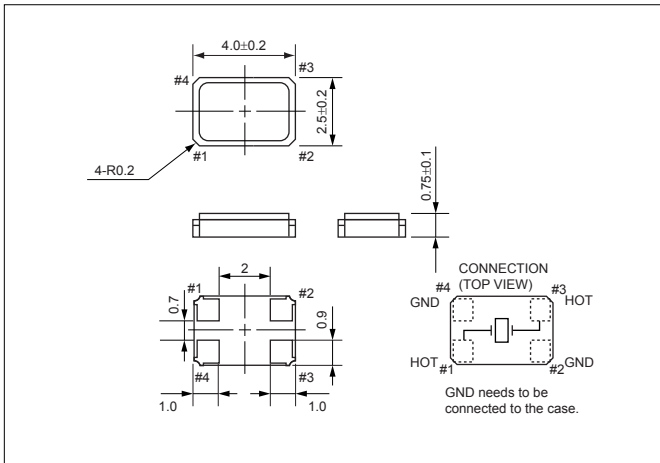

Recommended Land Pattern

(Unit : mm)

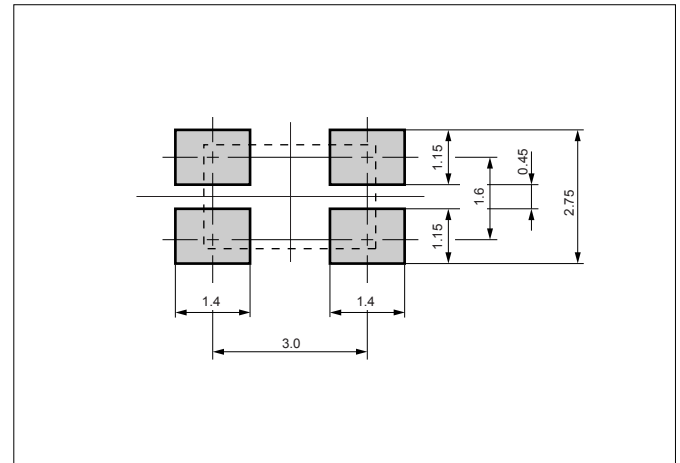

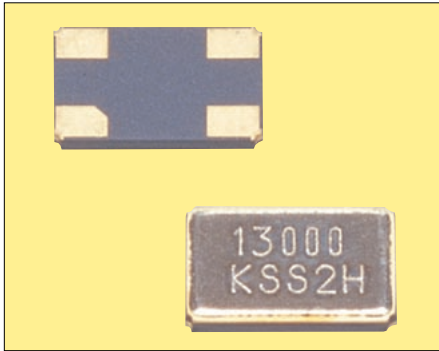

Pb Free

RoHS Compliant

Features

- Reference frequency for telecommunication systems
- Reflow compatible
- Using ceramic package resulting in high reliability
- Small and low profile

Applications

- Mobile Communications, Bluetooth, Wireless LAN

How to Order

CX5032SB 26000 F0 F L J ZZ
① ② ③ ④ ⑤ ⑥ ⑦

① Code

② Typical Frequencies

Code	Freq.(kHz)	Code	Freq.(kHz)
12000	12000.000	19200	19200.000
12800	12800.000	26000	26000.000
13000	13000.000	32000	32000.000
14400	14400.000	40000	40000.000
16000	16000.000	48000	48000.000

*Please inquire about frequencies other than the above.

③ Load Capacitance

F0	10pF
-----------	------

④ Frequency Stability

F	±10×10 ⁻⁶
----------	----------------------

⑤ Operating Temperature Range

L	-30°C to +85°C
----------	----------------

⑥ Frequency Temperature Stability

J	±15×10 ⁻⁶
----------	----------------------

⑦ Special

ZZ	Custom Specification
-----------	----------------------

Specifications

Items	Symbol	Specification	Units	Remarks
Frequency Range	f _{nom}	9843.75 to 49999	50 to 120(MHz)	kHz
Overtone Order	OT	Fundamental	3rd Overtone	—
Frequency Tolerance	f _{tol}	±10	×10 ⁻⁶	@ 25°C
Frequency Temp. Characteristics	f _{tem}	±15	×10 ⁻⁶	ref.@ 25°C Over Operating Temp. Range
Motional Series Resistance	R1	Table 1	ohm	
Level of Drive	DL	Table 2	μW	
Load Capacitance	CL	10	pF	
Operating Temp. Range	T _{use}	-30 to +85	°C	
Storage Temp. Range	T _{stg}	-40 to +85	°C	

* Please inquire about specifications other than the above.

Table1 Motional Series Resistances

Frequency Range	Motional Series Resistance	Units
9843.75 to 9999kHz	150	ohm
10000 to 11999kHz	80	
12000 to 25999kHz	50	
26000 to 49999kHz	40	
50 to 120(MHz)	80	

Table2 Level of Drive

Frequency Range	Level of Drive	Units
9843.75 to 49999kHz	10 (100 max.)	μW
50 to 120(MHz)(3rdO.T)	10 (100 max.)	

Dimensions

(Unit : mm)

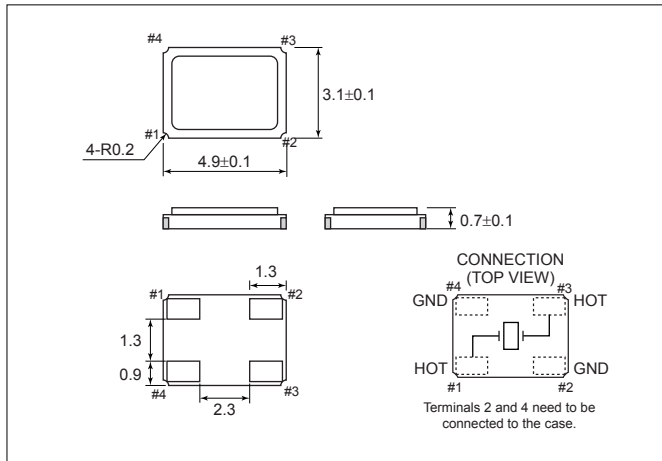

Recommended Land Pattern

(Unit : mm)

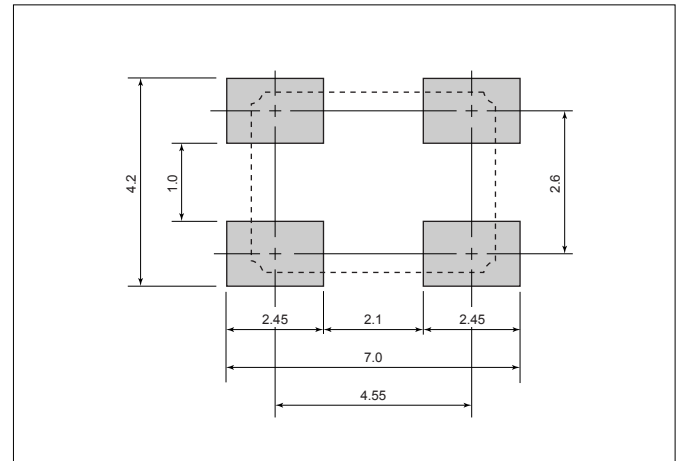

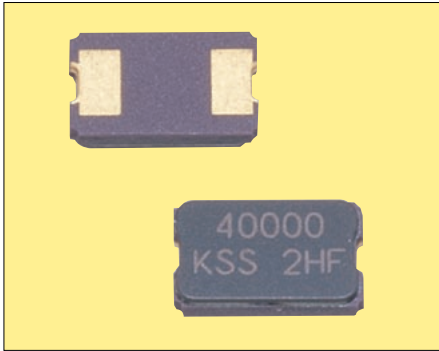

RoHS Compliant

Features

- Crystal unit for audio-visual, office equipment
- Small and low profile (5.0x3.2x1.0mm)
- Ceramic package
- Product with lead free terminations
- Reflow compatible

Applications

- Digital Electronics
- Audio-Visual, Office Equipment

How to Order

CX5032GB 48000 H0 P E S ZZ
 ① ② ③ ④ ⑤ ⑥ ⑦

① Code

② Typical Frequencies

Code	Freq.(kHz)	Code	Freq.(kHz)
10000	10000.000	24000	24000.000
12000	12000.000	24545	24545.450
14318	14318.180	24576	24576.000
14745	14745.600	27000	27000.000
16934	16934.400	36000	36000.000
18432	18432.000	48000	48000.000
22579	22579.200	54000	54000.000

*Please inquire about frequencies other than the above.

③ Load Capacitance

H0	12pF
-----------	------

④ Frequency Stability

P	$\pm 50 \times 10^{-6}$
----------	-------------------------

⑤ Operating Temperature Range

E	-10°C to +70°C
----------	----------------

⑥ Frequency Temperature Stability

S	$\pm 50 \times 10^{-6}$
----------	-------------------------

⑦ Special

ZZ	Custom Specification
-----------	----------------------

Specifications

Items	Symbol	Specification	Units	Remarks
Frequency Range	f _{nom}	9843.75 to 54000	kHz	
Overtone Order	OT	Fundamental	—	
Frequency Tolerance	f _{tol}	±50	×10 ⁻⁶	@ 25°C
Frequency Temp. Characteristics	f _{tem}	±50	×10 ⁻⁶	ref.@ 25°C Over Operating Temp. Range
Motional Series Resistance	R1	Table 1	ohm	
Level of Drive	DL	Table 2	μW	
Load Capacitance	CL	12	pF	
Operating Temp. Range	T _{use}	-10 to +70	°C	
Storage Temp. Range	T _{stg}	-40 to +85	°C	

* Please inquire about specifications other than the above.

Table1 Motional Series Resistances

Frequency Range	Motional Series Resistance	Units
9843.75 to 11999kHz	200	ohm
12000 to 13999kHz	150	
14000 to 29999kHz	100	
30000 to 54000kHz	50	

Table2 Level of Drive

Frequency Range	Level of Drive	Units
9843.75 to 15999kHz	10 (500 max.)	μW
16000 to 24999kHz	10 (300 max.)	
25000 to 54000kHz	10 (100 max.)	

Dimensions

(Unit : mm)

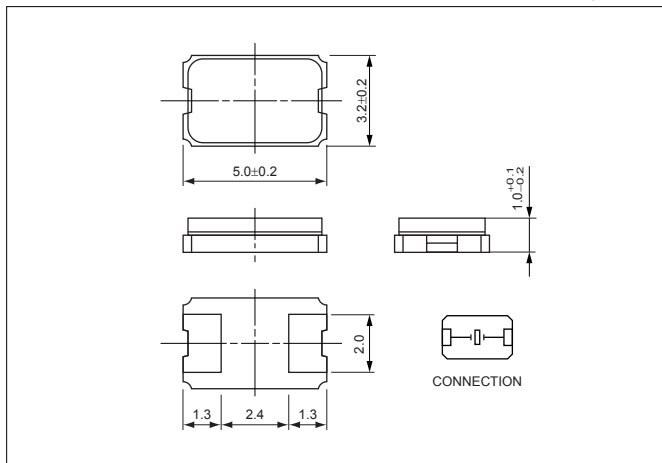

Recommended Land Pattern

(Unit : mm)

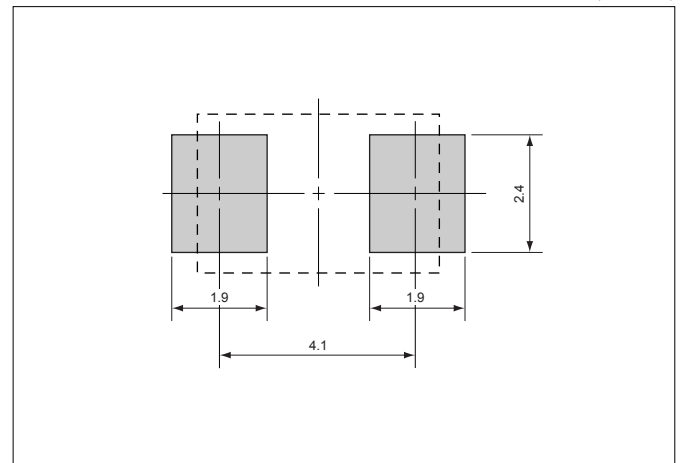



RoHS Compliant

Features

- Crystal unit for audio-visual, office equipment
- Small and low profile (8.0x4.5x1.8mm)
- Ceramic package
- Product with lead free terminations
- Reflow compatible

Applications

- Audio-Visual, Office Equipment

How to Order

CX8045GB 30000 H0 P E S ZZ
 ① ② ③ ④ ⑤ ⑥ ⑦

① Code

② Typical Frequencies

Code	Freq.(kHz)	Code	Freq.(kHz)
14318	14318.180	24576	24576.000
16000	16000.000	27000	27000.000
16384	16384.000	28636	28636.000
16934	16934.400	30000	30000.000
19660	19660.800	32000	32000.000
20000	20000.000	36000	36000.000
21477	21477.720	40000	40000.000
24000	24000.000		

*Please inquire about frequencies other than the above.

③ Load Capacitance

H0	12pF
----	------

④ Frequency Stability

P	$\pm 50 \times 10^{-6}$
---	-------------------------

⑤ Operating Temperature Range

E	-10°C to +70°C
---	----------------

⑥ Frequency Temperature Stability

S	$\pm 50 \times 10^{-6}$
---	-------------------------

⑦ Special

ZZ	Custom Specification
----	----------------------

Specifications

Items	Symbol	Specification	Units	Remarks
Frequency Range	f _{nom}	7200 to 48000	kHz	
Overtone Order	OT	Fundamental	—	
Frequency Tolerance	f _{tol}	±50	×10 ⁻⁶	@ 25°C
Frequency Temp. Characteristics	f _{tem}	±50	×10 ⁻⁶	ref.@ 25°C Over Operating Temp. Range
Motional Series Resistance	R1	Table 1	ohm	
Level of Drive	DL	Table 2	μW	
Load Capacitance	CL	12	pF	
Operating Temp. Range	T _{use}	-10 to +70	°C	
Storage Temp. Range	T _{stg}	-40 to +85	°C	

* Please inquire about specifications other than the above.

Table1 Motional Series Resistances

Frequency Range	Motional Series Resistance	Units
7200 to 9999kHz	200	ohm
10000 to 11999kHz	150	
12000 to 48000kHz	50	

Table2 Level of Drive

Frequency Range	Level of Drive	Units
7200 to 9999kHz	10 (500 max.)	μW
16000 to 24999kHz	10 (300 max.)	
25000 to 48000kHz	10 (100 max.)	

Dimensions

(Unit : mm)

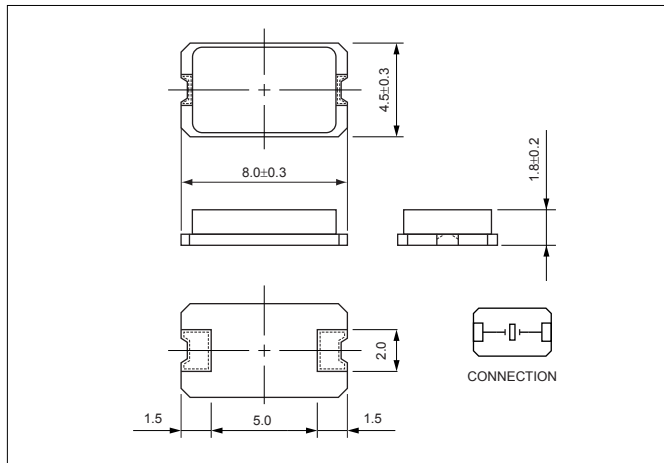

Recommended Land Pattern

(Unit : mm)

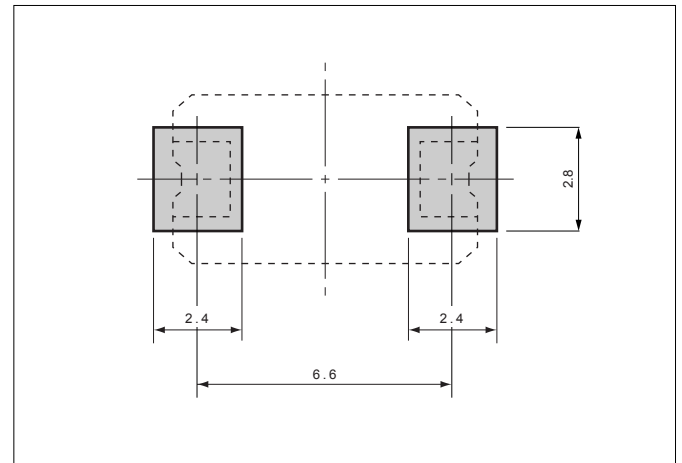

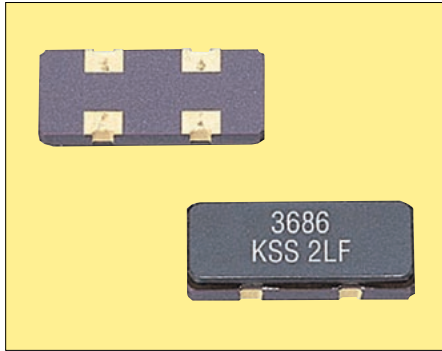

RoHS Compliant

Features

- Crystal unit for audio-visual, office equipment
- Small and low profile (11.8x5.5x1.8mm)
- Ceramic package
- Product with lead free terminations
- Reflow compatible

Applications

- Digital Electronics
- Audio-Visual, Office Equipment

How to Order

CXB855GB 03579 H0 P E S ZZ
 ① ② ③ ④ ⑤ ⑥ ⑦

① Code

② Typical Frequencies

Code	Freq.(kHz)	Code	Freq.(kHz)
03579	3579.545	14318	14318.180
03686	3686.400	16000	16000.000
04000	4000.000	16934	16934.400
06000	6000.000	19660	19660.800
08000	8000.000	20000	20000.000
12000	12000.000		

*Please inquire about frequencies other than the above.

③ Load Capacitance

H0	12pF
----	------

④ Frequency Stability

P	$\pm 50 \times 10^{-6}$
---	-------------------------

⑤ Operating Temperature Range

E	-10°C to +70°C
---	----------------

⑥ Frequency Temperature Stability

S	$\pm 50 \times 10^{-6}$
---	-------------------------

⑦ Special

ZZ	Custom Specification
----	----------------------

Specifications

Items	Symbol	Specification		Units	Remarks
Frequency Range	f _{nom}	3500 to 28999	29 to 60(MHz)	kHz	
Overtone Order	OT	Fundamental	3rd Overtone	—	
Frequency Tolerance	f _{tol}	±50		$\times 10^{-6}$	@ 25°C
Frequency Temp. Characteristics	f _{tem}	±50		$\times 10^{-6}$	ref. @ 25°C Over Operating Temp. Range
Motional Series Resistance	R1	Table 1		ohm	
Level of Drive	DL	Table 2		μW	
Load Capacitance	CL	12		pF	
Operating Temp. Range	T _{use}	-10 to +70		°C	
Storage Temp. Range	T _{stg}	-40 to +85		°C	

* Please inquire about specifications other than the above.

Table1 Motional Series Resistances

Frequency Range	Motional Series Resistance	Units
3500 to 3999kHz	300	ohm
4000 to 7999kHz	200	
8000 to 11999kHz	120	
12000 to 28999kHz	100	
29 to 60MHz	150	

Table2 Level of Drive

Frequency Range	Level of Drive	Units
3500 to 15999kHz	10 (500 max.)	μW
16000 to 28999kHz	10 (300 max.)	
29 to 60MHz	10 (300 max.)	

Dimensions

(Unit : mm)

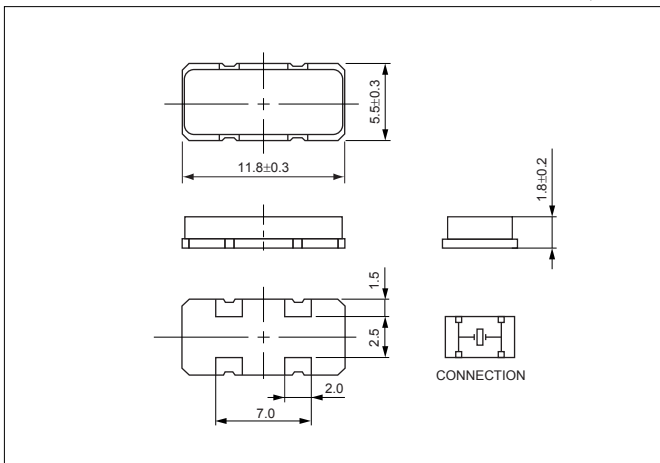

Recommended Land Pattern

(Unit : mm)

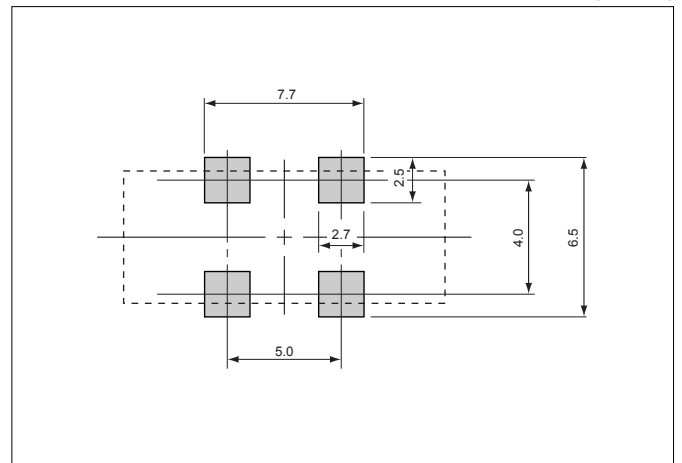

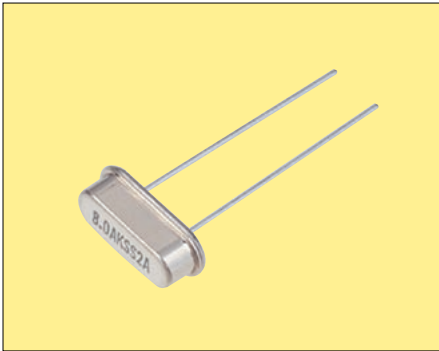

Pb Free

RoHS Compliant

Features

- Crystal unit for audio-visual, office equipment
- Metal package, leaded type
- A resistance weld hermetic sealed type
- Suitable for high density assembly and mass production

Applications

- Digital Electronics
- Audio-Visual, Office Equipment

How to Order

CXH49SFB 03579 H0 P E S ZZ
 ① ② ③ ④ ⑤ ⑥ ⑦

- ① Code
- ② Typical Frequencies

Code	Freq.(kHz)	Code	Freq.(kHz)
03200	3200.000	11000	11000.000
03579	3579.545	11059	11059.200
03686	3686.400	12000	12000.000
04000	4000.000	12288	12288.000
04194	4194.304	13500	13500.000
04332	4332.000	14318	14318.180
04433	4433.619	16000	16000.000
04500	4500.000	16934	16934.400
04915	4915.200	17280	17280.000
06000	6000.000	17734	17734.476
06144	6144.000	20000	20000.000
07200	7200.000	21477	21477.270
07372	7372.800	24000	24000.000
08000	8000.000	24576	24576.000
10000	10000.000	25000	25000.000
10240	10240.000	27000	27000.000
10738	10738.635		

*Please inquire about frequencies other than the above.

③ Load Capacitance

H0	12pF
-----------	------

④ Frequency Stability

P	$\pm 50 \times 10^{-6}$
----------	-------------------------

⑤ Operating Temperature Range

E	-10°C to +70°C
----------	----------------

⑥ Frequency Temperature Stability

S	$\pm 50 \times 10^{-6}$
----------	-------------------------

⑦ Special

ZZ	Custom Specification
-----------	----------------------

Specifications

Items	Symbol	Specification	Units	Remarks
Frequency Range	f _{nom}	3200 to 33999, 30 to 60(MHz)	kHz	
Overtone Order	OT	Fundamental, 3rd Overtone	—	
Frequency Tolerance	f _{tol}	±50	×10 ⁻⁶	@ 25°C
Frequency Temp. Characteristics	f _{tem}	±50	×10 ⁻⁶	ref.@ 25°C Over Operating Temp. Range
Motional Series Resistance	R1	Table 1	ohm	
Level of Drive	DL	Table 2	μW	
Load Capacitance	CL	12	pF	
Operating Temp. Range	T _{use}	-10 to +70	°C	
Storage Temp. Range	T _{stg}	-40 to +85	°C	

* Please inquire about specifications other than the above.

Table1 Motional Series Resistances

Frequency Range	Motional Series Resistance	Units
3200 to 3499kHz	300	ohm
3500 to 4099kHz	150	
4100 to 4799kHz	120	
4800 to 5999kHz	100	
6000 to 11999kHz	90	
12000 to 13499kHz	70	
13500 to 33999kHz	50	
30 to 60MHz	150	

Table2 Level of Drive

Frequency Range	Level of Drive	Units
3200 to 15999kHz	10 (500 max.)	μW
16000 to 24999kHz	10 (300 max.)	
25000 to 33999kHz	10 (100 max.)	
30 to 60MHz	10 (300 max.)	

Recommended Land Pattern

(Unit : mm)

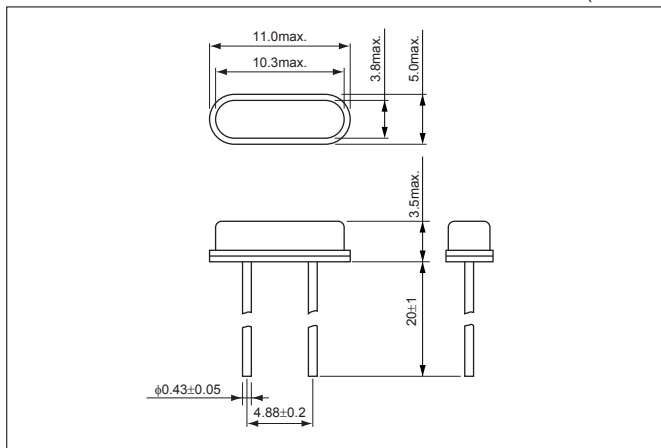



Pb Free

RoHS Compliant

Features

- Crystal unit for audio-visual, office equipment
- Metal package, leaded type
- A resistance weld hermetic sealed type
- Suitable for high density assembly and mass production

Applications

- Digital Electronics
- Audio-Visual, Office Equipment

How to Order

CXZ49GFB 03579 H0 P E S ZZ
 ① ② ③ ④ ⑤ ⑥ ⑦

① Code

② Typical Frequencies

Code	Freq.(kHz)	Code	Freq.(kHz)
03200	3200.000	11000	11000.000
03579	3579.545	11059	11059.200
03686	3686.400	12000	12000.000
04000	4000.000	12288	12288.000
04194	4194.304	13500	13500.000
04332	4332.000	14318	14318.180
04433	4433.619	16000	16000.000
04500	4500.000	16934	16934.400
04915	4915.200	17280	17280.000
06000	6000.000	17734	17734.476
06144	6144.000	20000	20000.000
07200	7200.000	21477	21477.270
07372	7372.800	24000	24000.000
08000	8000.000	24576	24576.000
10000	10000.000	25000	25000.000
10240	10240.000	27000	27000.000
10738	10738.635		

*Please inquire about frequencies other than the above.

③ Load Capacitance

H0	12pF
-----------	------

④ Frequency Stability

P	$\pm 50 \times 10^{-6}$
----------	-------------------------

⑤ Operating Temperature Range

E	-10°C to +70°C
----------	----------------

⑥ Frequency Temperature Stability

S	$\pm 50 \times 10^{-6}$
----------	-------------------------

⑦ Special

ZZ	Custom Specification
-----------	----------------------

Specifications

Items	Symbol	Specification	Units	Remarks
Frequency Range	f _{nom}	3200 to 33999, 30 to 60(MHz)	kHz	
Overtone Order	OT	Fundamental, 3rd Overtone	—	
Frequency Tolerance	f _{tol}	±50	×10 ⁻⁶	@ 25°C
Frequency Temp. Characteristics	f _{tem}	±50	×10 ⁻⁶	ref.@ 25°C Over Operating Temp. Range
Motional Series Resistance	R1	Table 1	ohm	
Level of Drive	DL	Table 2	μW	
Load Capacitance	CL	12	pF	
Operating Temp. Range	T _{use}	-10 to +70	°C	
Storage Temp. Range	T _{stg}	-40 to +85	°C	

* Please inquire about specifications other than the above.

Table1 Motional Series Resistances

Frequency Range	Motional Series Resistance	Units
3200 to 3499kHz	300	ohm
3500 to 4099kHz	150	
4100 to 4799kHz	120	
4800 to 5999kHz	100	
6000 to 11999kHz	90	
12000 to 13499kHz	70	
13500 to 33999kHz	50	
30 to 60MHz	150	

Table2 Level of Drive

Frequency Range	Level of Drive	Units
3200 to 15999kHz	10 (500 max.)	μW
16000 to 24999kHz	10 (300 max.)	
25000 to 33999kHz	10 (100 max.)	
30 to 60MHz	10 (300 max.)	

Dimensions

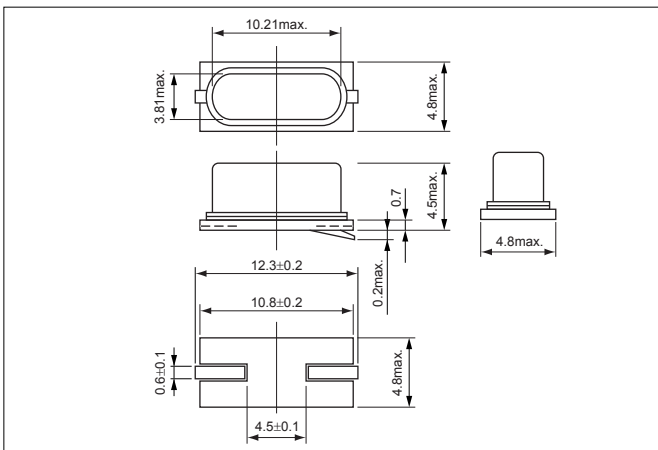

Recommended Land Pattern

(Unit : mm)

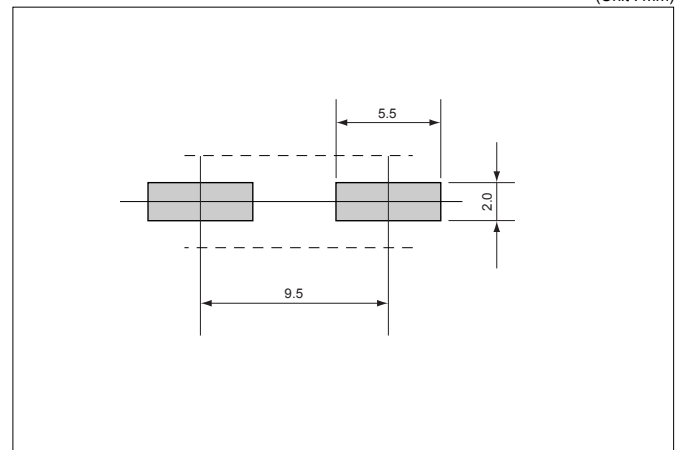



RoHS Compliant

Features

- Crystal unit for automotive electronics
- Small and low profile (5.0x3.2x1.3mm)
- Ceramic package
- Product with lead free terminations
- Reflow compatible

Applications

- Engine Control

How to Order

CX5032GA 16000 H0 Q S W ZZ
 ① ② ③ ④ ⑤ ⑥ ⑦

① Code

② Typical Frequencies

Code	Freq.(kHz)	Code	Freq.(kHz)
10000	10000.000	18000	18000.000
12000	12000.000	20000	20000.000
15000	15000.000	24000	24000.000
16000	16000.000	25000	25000.000

*Please inquire about frequencies other than the above.

③ Load Capacitance

H0	12pF
----	------

④ Frequency Stability

Q	$\pm 100 \times 10^{-6}$
---	--------------------------

⑤ Operating Temperature Range

S	-40°C to +125°C
---	-----------------

⑥ Frequency Temperature Stability

W	$\pm 200 \times 10^{-6}$
---	--------------------------

⑦ Special

ZZ	Custom Specification
----	----------------------

Specifications

Items	Symbol	Specification	Units	Remarks
Frequency Range	f _{nom}	9843.75 to 40000	kHz	
Overtone Order	OT	Fundamental	—	
Frequency Tolerance	f _{tol}	± 100	$\times 10^{-6}$	@ 25°C
Frequency Temp. Characteristics	f _{tem}	± 200	$\times 10^{-6}$	ref.@ 25°C Over Operating Temp. Range
Motional Series Resistance	R1	Table 1	ohm	
Level of Drive	DL	Table 2	μ W	
Load Capacitance	CL	12	pF	
Operating Temp. Range	T _{use}	-40 to +125	°C	
Storage Temp. Range	T _{stg}	-40 to +150	°C	

* Please inquire about specifications other than the above.

Table1 Motional Series Resistances

Frequency Range	Motional Series Resistance	Units
9843.75 to 11999kHz	200	ohm
12000 to 13999kHz	150	
14000 to 29999kHz	100	
30000 to 40000kHz	50	

Table2 Level of Drive

Frequency Range	Level of Drive	Units
9843.75 to 15999kHz	10 (500 max.)	μ W
16000 to 24999kHz	10 (300 max.)	
25000 to 40000kHz	10 (100 max.)	

Dimensions

(Unit : mm)

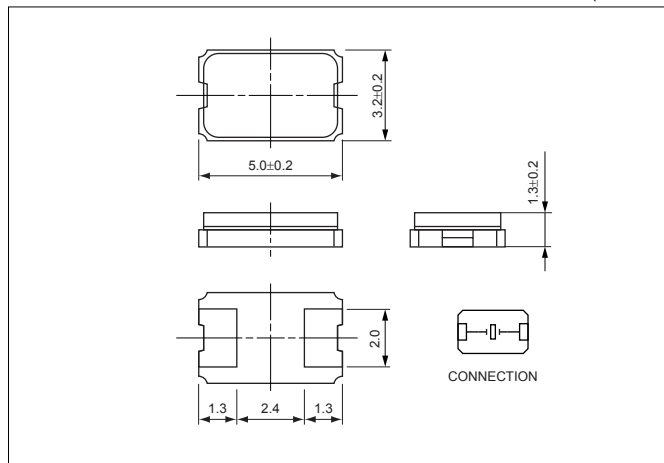

Recommended Land Pattern

(Unit : mm)

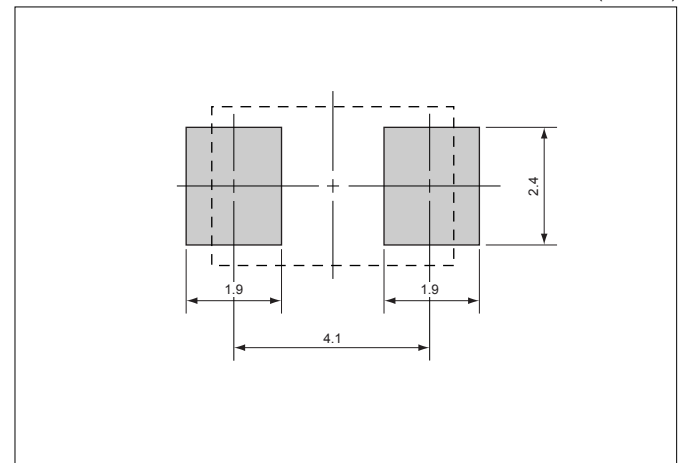



RoHS Compliant

Features

- Crystal unit for automotive electronics
- Small and low profile (8.0x4.5x1.9mm)
- Ceramic package, J lead type
- Product with lead free terminations
- Reflow compatible

Applications

- Engine Control, TPMS

How to Order

CX8045JA 08000 H0 Q S W ZZ
 ① ② ③ ④ ⑤ ⑥ ⑦

①Code

②Typical Frequencies

Code	Freq.(kHz)	Code	Freq.(kHz)
08000	8000.000	16000	16000.000
09843	9843.750	18000	18000.000
10000	10000.000	20000	20000.000
12000	12000.000	24000	24000.000
13560	13560.000	25000	25000.000
14000	14000.000	30000	30000.000

*Please inquire about frequencies other than the above.

③Load Capacitance

H0	12pF
----	------

④Frequency Stability

Q	±100×10 ⁻⁶
---	-----------------------

⑤Operating Temperature Range

S	-40°C to +125°C
---	-----------------

⑥Frequency Temperature Stability

W	±200×10 ⁻⁶
---	-----------------------

⑦Special

ZZ	Custom Specification
----	----------------------

Specifications

Items	Symbol	Specification	Units	Remarks
Frequency Range	f _{nom}	8000 to 30000	kHz	
Overtone Order	OT	Fundamental	—	
Frequency Tolerance	f _{tol}	±100	×10 ⁻⁶	@ 25°C
Frequency Temp. Characteristics	f _{tem}	±200	×10 ⁻⁶	ref.@ 25°C Over Operating Temp. Range
Motional Series Resistance	R1	Table 1	ohm	
Level of Drive	DL	Table 2	μW	
Load Capacitance	CL	12	pF	
Operating Temp. Range	T _{use}	-40 to +125	°C	
Storage Temp. Range	T _{stg}	-40 to +150	°C	

* Please inquire about specifications other than the above.

Table1 Motional Series Resistances

Frequency Range	Motional Series Resistance	Units
8000 to 9999kHz	200	ohm
10000 to 11999kHz	150	
12000 to 30000kHz	100	

Table2 Level of Drive

Frequency Range	Level of Drive	Units
8000 to 15999kHz	10 (500 max.)	μW
16000 to 24999kHz	10 (300 max.)	
25000 to 30000kHz	10 (100 max.)	

Dimensions

(Unit : mm)

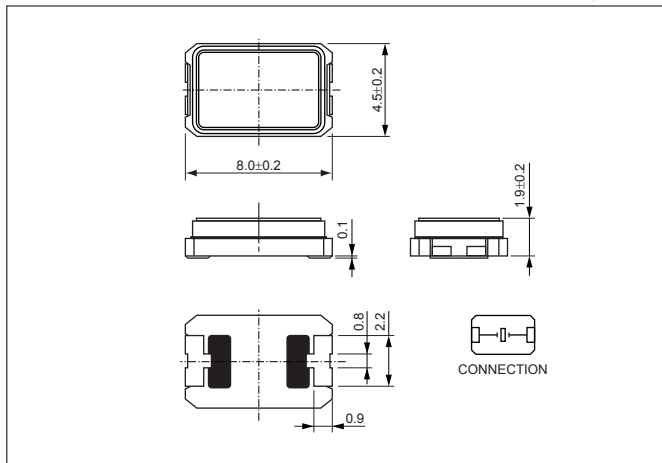

Recommended Land Pattern

(Unit : mm)

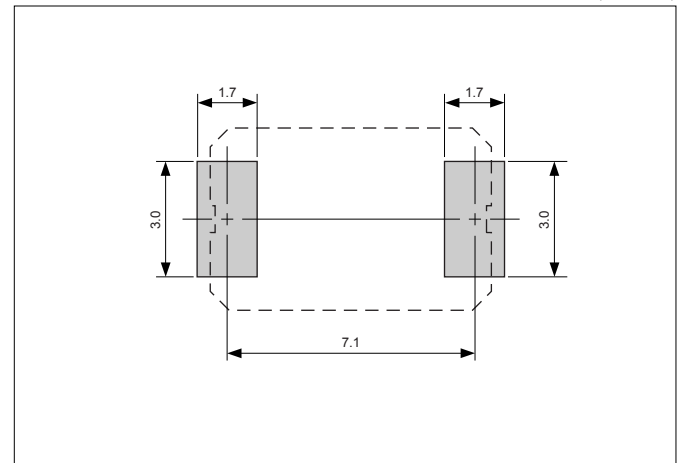

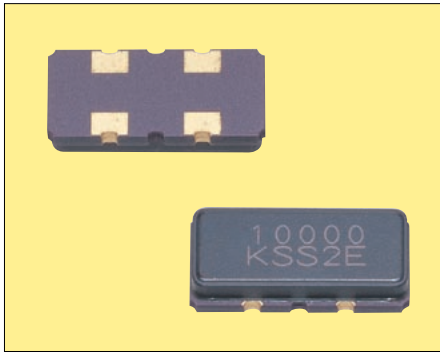

RoHS Compliant

Features

- Crystal unit for automotive electronics
- Small and low profile (11.8×5.5×2.5mm)
- Ceramic package
- Product with lead free terminations
- Reflow compatible

Applications

- Engine Control

How to Order

CXB855GA 06000 H0 Q S W ZZ
 ① ② ③ ④ ⑤ ⑥ ⑦

① Code

② Typical Frequencies

Code	Freq.(kHz)	Code	Freq.(kHz)
04000	4000.000	12000	12000.000
05000	5000.000	16000	16000.000
06000	6000.000	18000	18000.000
08000	8000.000	20000	20000.000
10000	10000.000		

*Please inquire about frequencies other than the above.

③ Load Capacitance

H0	12pF
-----------	------

④ Frequency Stability

Q	±100×10 ⁻⁶
----------	-----------------------

⑤ Operating Temperature Range

S	-40°C to +125°C
----------	-----------------

⑥ Frequency Temperature Stability

W	±200×10 ⁻⁶
----------	-----------------------

⑦ Special

ZZ	Custom Specification
-----------	----------------------

Specifications

Items	Symbol	Specification	Units	Remarks
Frequency Range	f _{nom}	3500 to 20000	kHz	
Overtone Order	OT	Fundamental	—	
Frequency Tolerance	f _{tol}	±100	×10 ⁻⁶	@ 25°C
Frequency Temp. Characteristics	f _{tem}	±200	×10 ⁻⁶	ref.@ 25°C Over Operating Temp. Range
Motional Series Resistance	R1	Table 1	ohm	
Level of Drive	DL	Table 2	μW	
Load Capacitance	CL	12	pF	
Operating Temp. Range	T _{use}	-40 to +125	°C	
Storage Temp. Range	T _{stg}	-40 to +125	°C	

* Please inquire about specifications other than the above.

Table1 Motional Series Resistances

Frequency Range	Motional Series Resistance	Units
3500 to 3999kHz	300	ohm
4000 to 7999kHz	200	
8000 to 11999kHz	120	
12000 to 20000kHz	100	

Table2 Level of Drive

Frequency Range	Level of Drive	Units
3500 to 15999kHz	10 (500 max.)	μW
16000 to 20000kHz	10 (300 max.)	

Dimensions

(Unit : mm)

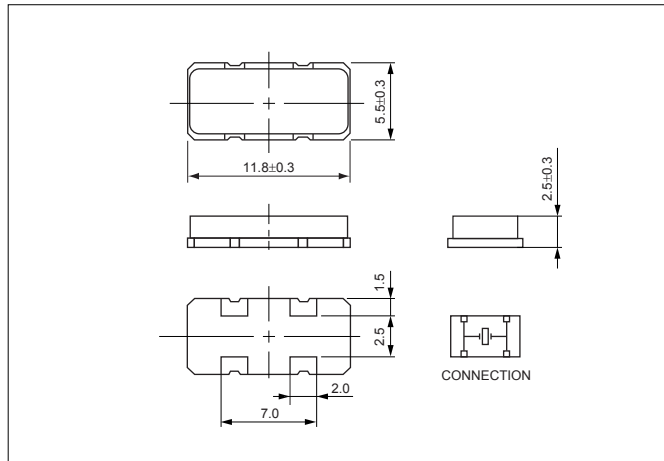

Recommended Land Pattern

(Unit : mm)

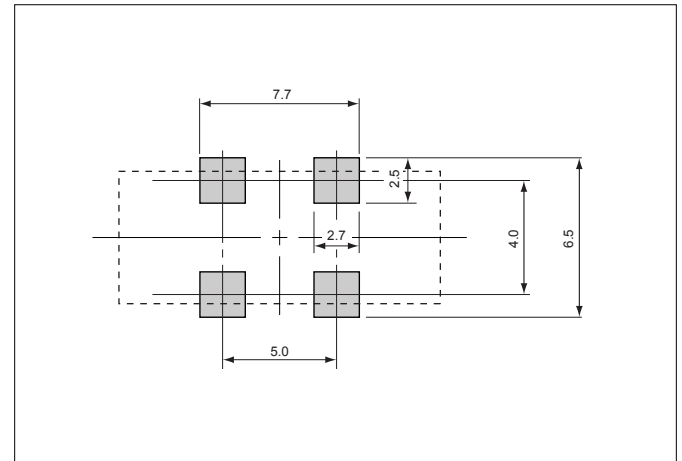

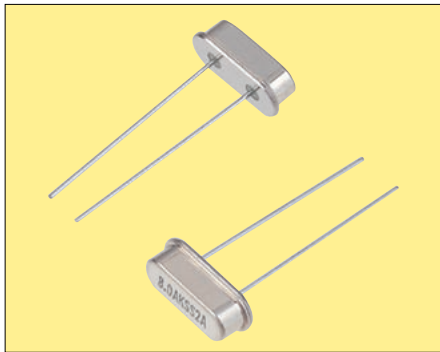

Pb Free

RoHS Compliant

Features

- Crystal unit for automotive electronics
- Metal package, leaded type
- A resistance weld hermetic sealed type
- Suitable for high density assembly and mass production

Applications

- Engine Control

How to Order

CXH49SFA 06000 H0 Q S W ZZ
 ① ② ③ ④ ⑤ ⑥ ⑦

① Code

② Typical Frequencies

Code	Freq.(kHz)	Code	Freq.(kHz)
04000	4000.000	12000	12000.000
05000	5000.000	16000	16000.000
06000	6000.000	18000	18000.000
08000	8000.000	20000	20000.000
10000	10000.000		

*Please inquire about frequencies other than the above.

③ Load Capacitance

H0	12pF
-----------	------

④ Frequency Stability

Q	$\pm 100 \times 10^{-6}$
----------	--------------------------

⑤ Operating Temperature Range

S	-40°C to +125°C
----------	-----------------

⑥ Frequency Temperature Stability

W	$\pm 200 \times 10^{-6}$
----------	--------------------------

⑦ Special

ZZ	Custom Specification
-----------	----------------------

Specifications

Items	Symbol	Specification	Units	Remarks
Frequency Range	f _{nom}	3200 to 20000	kHz	
Overtone Order	OT	Fundamental	—	
Frequency Tolerance	f _{tol}	± 100	$\times 10^{-6}$	@ 25°C
Frequency Temp. Characteristics	f _{tem}	± 200	$\times 10^{-6}$	ref.@ 25°C Over Operating Temp. Range
Motional Series Resistance	R1	Table 1	ohm	
Level of Drive	DL	Table 2	μW	
Load Capacitance	CL	12	pF	
Operating Temp. Range	T _{use}	-40 to +125	°C	
Storage Temp. Range	T _{stg}	-40 to +125	°C	

* Please inquire about specifications other than the above.

Table1 Motional Series Resistances

Frequency Range	Motional Series Resistance	Units
3200 to 3499kHz	300	ohm
3500 to 4099kHz	150	
4100 to 4799kHz	120	
4800 to 5999kHz	100	
6000 to 11999kHz	90	
12000 to 13499kHz	70	
13500 to 20000kHz	50	

Table2 Level of Drive

Frequency Range	Level of Drive	Units
3200 to 15999kHz	10 (500 max.)	μW
16000 to 20000kHz	10 (300 max.)	

Dimensions

(Unit : mm)

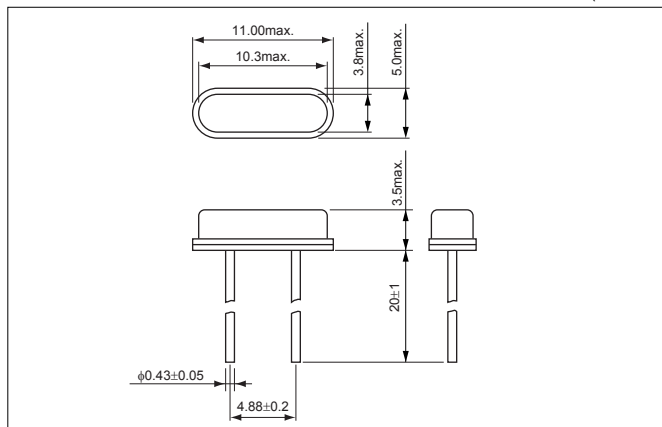



Pb Free

RoHS Compliant

Features

- Crystal unit for automotive electronics
- Metal package, leaded type
- A resistance weld hermetic sealed type
- Suitable for high density assembly and mass production

Applications

- Engine Control

How to Order

CXZ49FFA 06000 H0 Q S W ZZ
 ① ② ③ ④ ⑤ ⑥ ⑦

- ① Code
- ② Typical Frequencies

Code	Freq.(kHz)	Code	Freq.(kHz)
04000	4000.000	12000	12000.000
05000	5000.000	16000	16000.000
06000	6000.000	18000	18000.000
08000	8000.000	20000	20000.000
10000	10000.000		

*Please inquire about frequencies other than the above.

- ③ Load Capacitance

H0	12pF
-----------	------

- ④ Frequency Stability

Q	$\pm 100 \times 10^{-6}$
----------	--------------------------

- ⑤ Operating Temperature Range

S	-40°C to +125°C
----------	-----------------

- ⑥ Frequency Temperature Stability

W	$\pm 200 \times 10^{-6}$
----------	--------------------------

- ⑦ Special

ZZ	Custom Specification
-----------	----------------------

Specifications

Items	Symbol	Specification	Units	Remarks
Frequency Range	f _{nom}	3200 to 20000	kHz	
Overtone Order	OT	Fundamental	—	
Frequency Tolerance	f _{tol}	± 100	$\times 10^{-6}$	@ 25°C
Frequency Temp. Characteristics	f _{tem}	± 200	$\times 10^{-6}$	ref.@ 25°C Over Operating Temp. Range
Motional Series Resistance	R1	Table 1	ohm	
Level of Drive	DL	Table 2	μW	
Load Capacitance	CL	12	pF	
Operating Temp. Range	T _{use}	-40 to +125	°C	
Storage Temp. Range	T _{stg}	-40 to +125	°C	

* Please inquire about specifications other than the above.

Table1 Motional Series Resistances

Frequency Range	Motional Series Resistance	Units
3200 to 3499kHz	300	ohm
3500 to 4099kHz	150	
4100 to 4799kHz	120	
4800 to 5999kHz	100	
6000 to 11999kHz	90	
12000 to 13499kHz	70	
13500 to 20000kHz	50	

Table2 Level of Drive

Frequency Range	Level of Drive	Units
3200 to 15999kHz	10 (500 max.)	μW
16000 to 20000kHz	10 (300 max.)	

Dimensions

(Unit : mm)

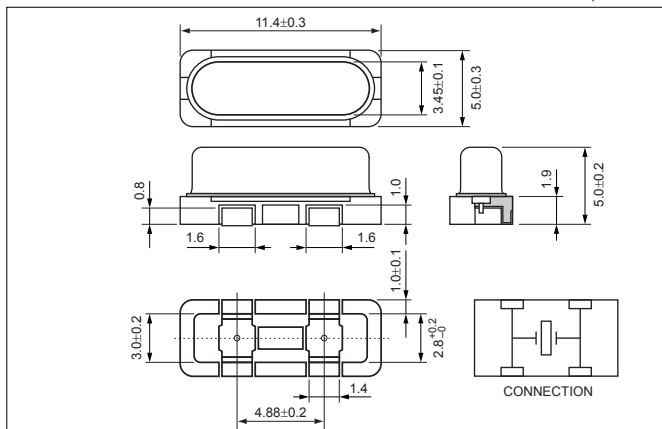

Recommended Land Pattern

(Unit : mm)

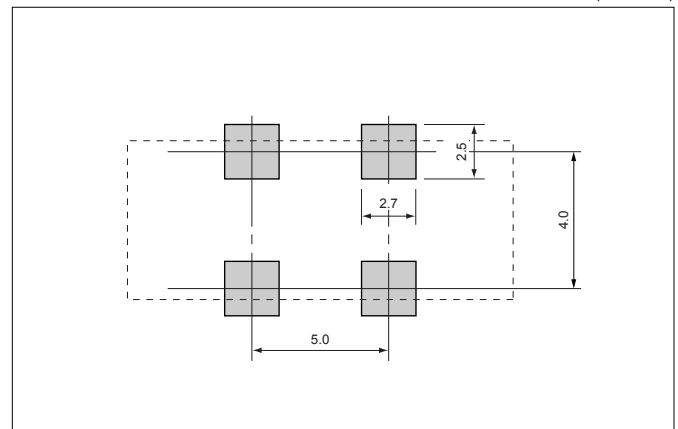



Features

- Crystal unit for automotive electronics
- Metal package, leaded type
- A resistance weld hermetic sealed type
- Suitable for high density assembly and mass production

Applications

- Engine Control

How to Order

CXZ49LFA 06000 H0 Q S W ZZ
 ① ② ③ ④ ⑤ ⑥ ⑦

- ① Code
- ② Typical Frequencies

Code	Freq.(kHz)	Code	Freq.(kHz)
04000	4000.000	12000	12000.000
05000	5000.000	16000	16000.000
06000	6000.000	18000	18000.000
08000	8000.000	20000	20000.000
10000	10000.000		

*Please inquire about frequencies other than the above.

- ③ Load Capacitance

H0	12pF
-----------	------

- ④ Frequency Stability

Q	$\pm 100 \times 10^{-6}$
----------	--------------------------

- ⑤ Operating Temperature Range

S	-40°C to +125°C
----------	-----------------

- ⑥ Frequency Temperature Stability

W	$\pm 200 \times 10^{-6}$
----------	--------------------------

- ⑦ Special

ZZ	Custom Specification
-----------	----------------------

Specifications

Items	Symbol	Specification	Units	Remarks
Frequency Range	f _{nom}	3200 to 20000	kHz	
Overtone Order	OT	Fundamental	—	
Frequency Tolerance	f _{tol}	±100	×10 ⁻⁶	@ 25°C
Frequency Temp. Characteristics	f _{tem}	±200	×10 ⁻⁶	ref.@ 25°C Over Operating Temp. Range
Motional Series Resistance	R1	Table 1	ohm	
Level of Drive	DL	Table 2	μW	
Load Capacitance	CL	12	pF	
Operating Temp. Range	T _{use}	-40 to +125	°C	
Storage Temp. Range	T _{stg}	-40 to +125	°C	

* Please inquire about specifications other than the above.

Table1 Motional Series Resistances

Frequency Range	Motional Series Resistance	Units
3200 to 3499kHz	300	ohm
3500 to 4099kHz	150	
4100 to 4799kHz	120	
4800 to 5999kHz	100	
6000 to 11999kHz	90	
12000 to 13499kHz	70	
13500 to 20000kHz	50	

Table2 Level of Drive

Frequency Range	Level of Drive	Units
3200 to 15999kHz	10 (500 max.)	μW
16000 to 20000kHz	10 (300 max.)	

Dimensions

(Unit : mm)

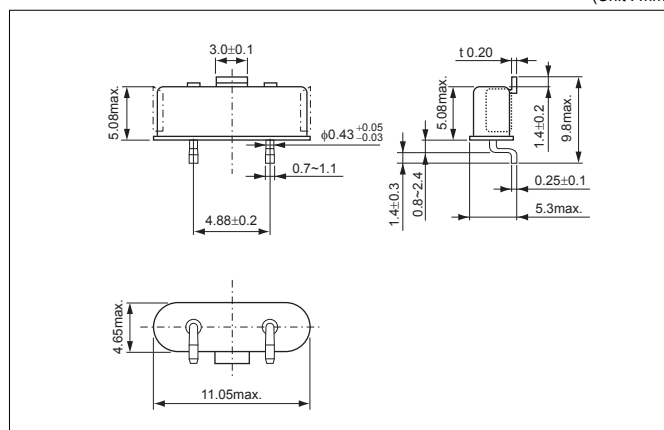

Recommended Land Pattern

(Unit : mm)

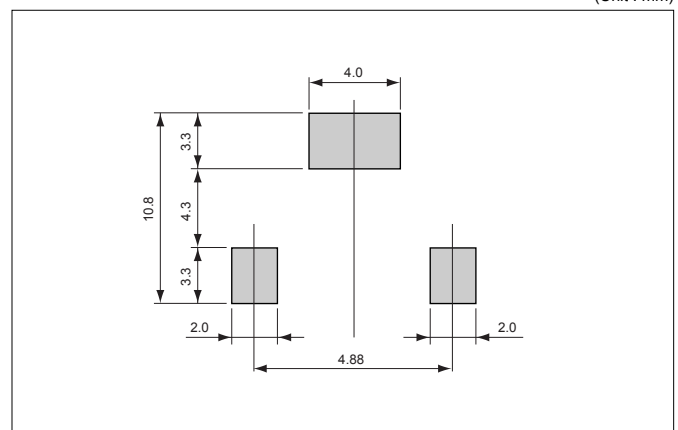

1. Shock & Drop • Vibration

Do not inflict excessive shock and mechanical vibration that exceeds the norm, such as hitting or mistakenly dropping, when transporting and mounting on a board. There are cases when pieces of crystal break, and pieces that are used become damaged, and become inoperable. When a shock or vibration that exceeds the norm has been inflicted, make sure to check the characteristics.

2. Cleaning

Since a crystal piece can be broken by resonance when a crystal device is cleaned by ultrasonic cleaning. Be careful when carrying out ultrasonic cleaning.

3. Soldering conditions

To maintain the product reliability, please follow recommended conditions.

Standard soldering iron conditions

	Crystal Units
Soldering iron	280°C to 340°C
Time	3+ 1/-0sec. max.

Reflow conditions (Example)

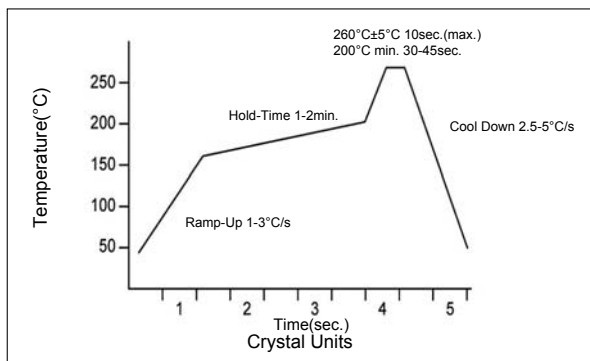

Recommended reflow Conditions vary depending upon products. Please check with the respective specification for details.

4. Mounting Precautions

Leaded Devices

The special glass, located where the lead of the retainer base comes out, is aligned with the coefficient of thermal expansion of the lead, If the glass is damaged and cracks appear, there may be cases in which performance deteriorates and it fails to operate.

Consequently, when making the device adhere closely and applying solder, align the gap of the hole of the board with the gap of the lead and insert without excessive force.

When making the device adhere closely to a through hole board and applying solder, be careful that the solder does not get into the metal part of the retainer base and cause a short. Putting in an insulation spacer is one more method of preventing a short circuit.

When the lead is mounted floating, fix it as far as possible so that contact with other parts and the breakage due to the fatigue, and the mechanical resonance of the lead will not occur.

When the lead is bent and used, do not bend the lead directly from the base, separate it 0.5mm or more and then bend it. When bending, before attaching to the board, fix the place where the lead comes out in advance and attach it after bending so that a crack does not occur in the glass part.

Surface Mount Devices

The lead of the device and the pattern of the board is soldered on the surface. Since extreme deformation of the board tears off the pattern, tears off the lead metal, cracks the solder and damages the sealed part of the device and there are cases in which performance deteriorates and operation fails, use it within the stipulated bending conditions. Due to the small cracks in the board resulting from mounting, please pay sufficient attention when attaching a device at the position where the warping of the board is great.

When using an automatic loading machine, as far as possible, select a type that has a small impact and use it while confirming that there is no damage.

Surface mount devices are NOT flow soldering compatible.

5. Storage Condition

Since the long hour high temperature and low temperature storage, as well as the storage at high humidity are causes of deterioration in frequency accuracy and solderability.

Parts should be stored in temperature range of -5 to +40°C, humidity 40 to 60% RH, and avoid direct sunlight. Then use within 6 months.

For Proper Use of Crystal Units

1. Characteristics of crystal units

The thickness of crystal vibrator of the AT cut crystal unit as described in the previous page differs depending on the overtone mode.

(1) Relationship between thickness of crystal blank and oscillation frequency

Cut angle/mode overtone	Frequency range (MHz)	Formula of thickness of crystal blank
AT/Fundamental mode	3.5 to 33	$1.67/f$
AT/3 rd O. T	33 to 100	$5.01/f$
AT/5 th O. T	100 to 150	$8.35/f$
AT/7 th O. T	150 to 200	$11.69/f$

f : Series resonance frequency (MHz)

In case of calculating the thickness of AT-cut 16MHz
 $t = 1.67/16 = 0.104(\text{mm})$

(2) Examples of specifications for frequency-temperature characteristics

The frequency-temperature characteristics of the AT cut crystal unit are tertiary curves.

The diagram below shows examples of the tertiary curves that pass temperature range and frequency deviation specifications.

The range enclosed by the smaller rectangular satisfies the following specification:

$$\pm 10 \times 10^{-6} \text{ (-10 to 60: 25}^\circ\text{C)}$$

The range enclosed by the larger rectangular satisfies the following specification:

$$\pm 50 \times 10^{-6} \text{ (-20 to 70: 25}^\circ\text{C)}$$

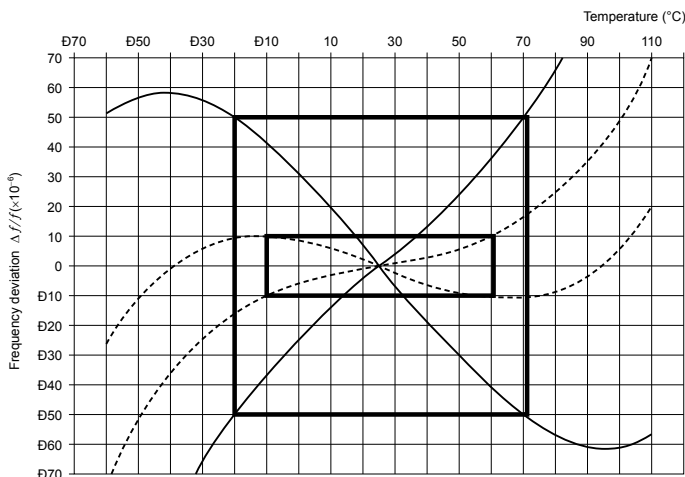

* These are examples. Required frequency-temperature specifications are determined through individual consultations.

(3) Equivalent electric circuit and equivalent constant of crystal unit

The following equivalent constants are used near the resonance frequency.

L_1 : Motional inductance in the equivalent electric circuit

C_1 : Motional capacitance in the equivalent electric circuit

R : Motional resistance in the equivalent electric circuit

C_0 : Parallel capacitance in the equivalent electric circuit

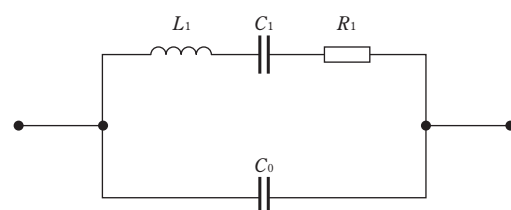

Equivalent electric circuit of a quartz crystal unit

(4) Items calculated by equivalent constants and load capacitance

f_s : Series resonance frequency	$f_s = \frac{1}{2\pi\sqrt{L_1 \cdot C_1}}$
f_p : Parallel resonance frequency	$f_p = \frac{1}{2\pi\sqrt{L_1 \frac{C_0 \cdot C_1}{C_0 + C_1}}}$
γ : Capacitance ratio	$\gamma = \frac{C_0}{C_1}$
f_L : Load resonance frequency	$f_L = f_s \left(\frac{C_1}{2 \cdot (C_0 + C_L)} + 1 \right)$
R_L : Load resistance	$R_L = R_1 \left(1 + \frac{C_0}{C_L} \right)^2$
C_L : Load capacitance	$C_L = \frac{C_1}{2} \cdot \frac{1}{(f_L/f_s)^2 - 1} - C_0$
Q : Quality factor	$Q = \frac{2\pi \cdot f_s \cdot L_1}{R_1} = \frac{1}{2\pi \cdot f_s \cdot C_1 \cdot R_1}$

The equation f_L shows that f_L varies as load capacitance C_L connected to the crystal unit changes and that f_L becomes larger as C_L becomes smaller.

The equation R_L shows the change in impedance with a load capacitance connected. The impedance of crystal unit becomes larger as C_L becomes smaller.

2. Oscillation circuit and crystal unit

(1) Equivalent circuit of oscillation circuit and oscillation conditions

A simplified equivalent circuit is shown below.

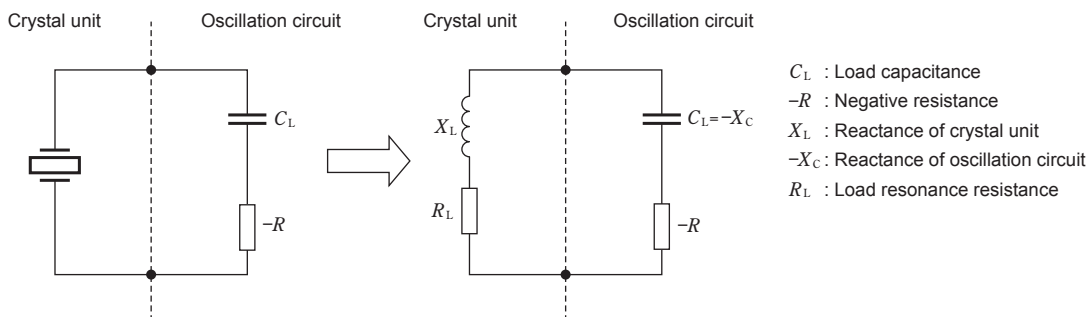

The oscillation start-up conditions are described as

$$R_L \leq |-R|$$

and in order to oscillate the crystal unit accurately, it must be designed such that the negative resistance of the oscillation circuit becomes bigger comparing with the resonance resistance value at the time of loading. This ratio is called oscillation margin degree M_{osc} and it is one of critical factors when designing the oscillation circuit and is described as below.

For oscillation circuit designing conditions, it is recommended that an oscillation circuit be designed using a negative resistance of a value five to ten times or more larger than R_L calculated from the resonance resistance specification value.

$$M_{osc} = |-R| / R_L \geq 5$$

In a steady oscillation state, the load resonance resistance is given as follows:

$$R_L = |-R|$$

The mutual conductance of the oscillation circuit decreases after the oscillation has started to continuously compensate for the power loss due to the load resonance resistance of the crystal unit, which continues oscillation.

The frequency condition is given as follows:

$$X_L = X_C, X_L - X_C = 0$$

As shown in the following figure, the reactance of the crystal unit varies to a value matching the load capacitance of the oscillation circuit $C_L = X_C$. Thus an oscillation frequency is determined.

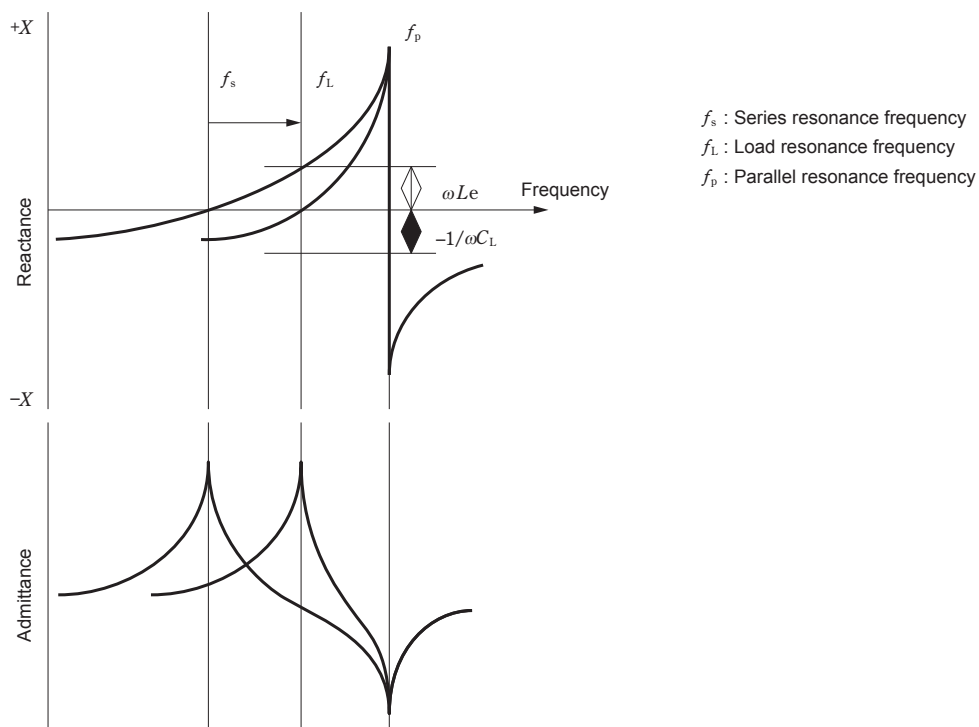

(2) Changes of load capacitance and oscillation frequency

As shown above, the series resonance frequency of the crystal unit changes with load capacitance C_L of the oscillation circuit. In the actual oscillation circuit, however, fine adjustments of oscillation frequencies are carried out by varying C_L by the trimmer capacitor or the like. The following figure shows an example of load capacity characteristics. The slope of the characteristics varies depending on the frequency, shape, the number of overtone mode, etc.

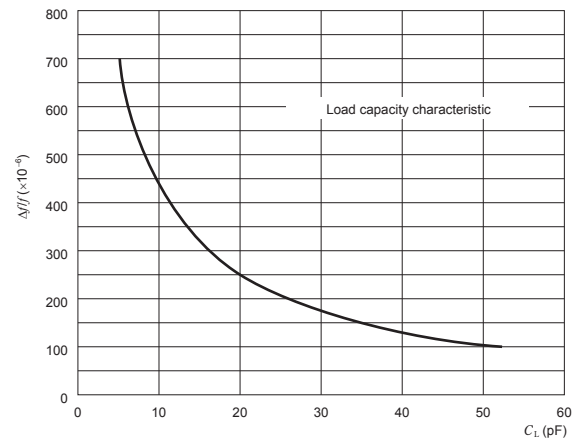

3. Crystal oscillation circuit

(1) CMOS fundamental crystal oscillation circuit

As shown above, the series resonance frequency of the crystal The figure on the right shows a standard CMOS inverter crystal oscillation circuit for oscillating crystal unit with fundamental mode. * R_x is an element to reduce excitation current of the crystal unit preventing frequency fluctuation, but R_x is not used in some cases.

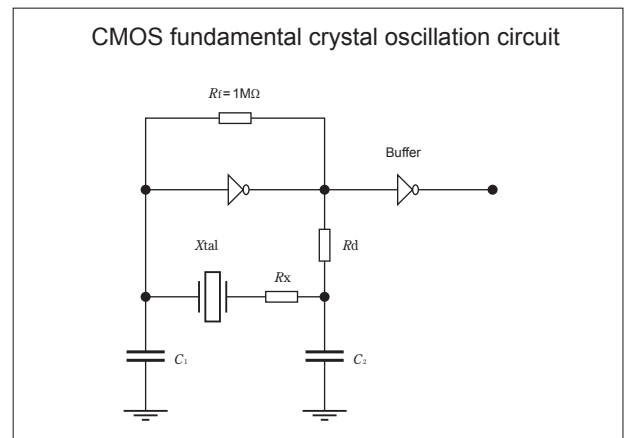

Characteristics of the circuit when load capacitances C_1 and C_2 are changed under the condition of $C_1 = C_2$ are shown in the figure on the right. It is not desirable that the excessive increase of the value of condenser leads to a decrease of the negative resistance resulting in increasing the possibility of oscillation failure.

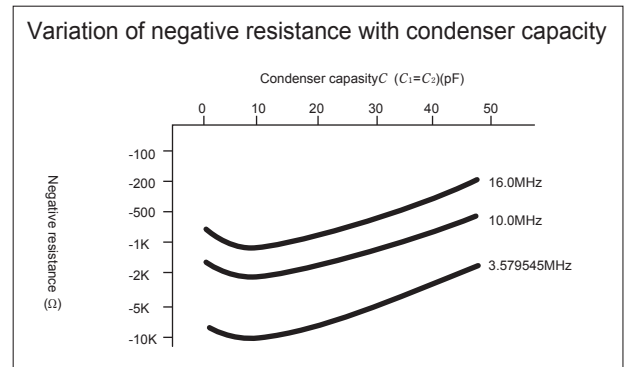

R_d mainly adjusts frequency characteristics of the negative resistance and is used to prevent oscillating by third Overtone mode. In case of a bigger circuit of the negative resistance, there is a case it is used to prevent the abnormal oscillation.

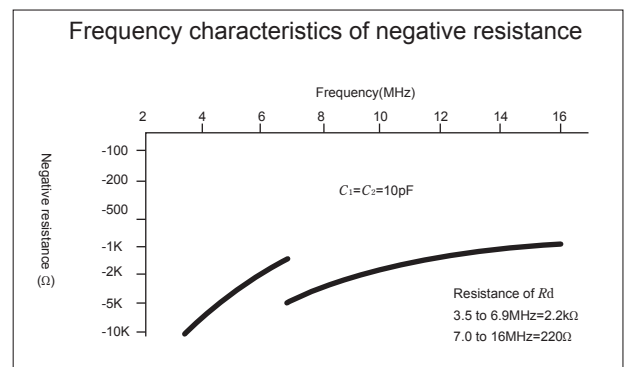

Selection of ICs and circuit constants by frequency bands

Frequency	3 to 4.9(MHz)	5 to 6.9(MHz)	7 to 9.9(MHz)	10 to 19.9(MHz)	20 to 30(MHz)
IC	TC4069UB TC4SU69F			TC74HCU04A TC7SU04F TC7WU04FU	TC74VHCU04 TC7SHU04F TC7WHU04FU
R_f	1M Ω				
R_d *1	1500(Ω)	470(Ω)	0(Ω)	0(Ω)	0(Ω)
R_x *2	0 to 1500 Ω				
C_1, C_2 *3	6 to 22(pF)			6 to 15(pF)	6 to 15(pF)

*1: Necessary for preventing overtone oscillation and must be changed depending on the frequency band or the C_1 and C_2 values.

*2: Used to reduce excitation current of the crystal unit. Necessary for stable operation of small-sized crystal units.

*3: The optimum value differs with the values of load capacitance and R_d .

(2) CMOS overtone crystal oscillation circuit

This figure shows a standard CMOS inverter crystal oscillation circuit to oscillate a crystal unit using the overtone mode.

CMOS overtone crystal oscillation circuit

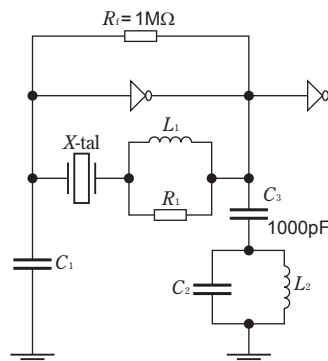

There are same cases when L_1 and R_1 are matched to the value of load capacitance.

(3) Selection of ICs and circuit constants by frequency bands

Frequency range	20 to 60(MHz)
IC	TC74VHCU04 TC7SHU04F TC7WHU04FU
C_1	3 to 10pF
C_2	10 to 22pF

(4) Method of selecting circuit constants and functions of elements

C_1 : Forms load capacitance of the circuit together with C_2 , L_1 and L_2 . A value of approx. 5pF is used.

C_2 : Forms load capacitance of the circuit together with C_1 , L_1 and L_2 . Prevents fundamental wave oscillation. Shall be selected so that C_2 comes between the third overtone frequency at which resonance frequency with L_2 is to make oscillation and 1/3 of the third overtone frequency. A value of 10 to 22pF is used.

C_3 : A bypass capacitor

L_1 : A coil to adjust load capacitance of the oscillation circuit to a value near the series. A value of several μ H is used.

L_2 : Forms load capacitance of the circuit together with C_1 , C_2 and L_1 . Prevents fundamental wave oscillation. Shall be selected so that L_2 comes between the third overtone frequency at which resonance frequency with C_2 is to make oscillation and 1/3 of the third overtone frequency. A value of 10 to 22pF is used.

R_1 : A Q dump resistor for L_1 . As an element for preventing self-excited oscillation, A value of several k Ω to several tens of k Ω is used.

* L_1 and R_1 might not be used.

(5) Method of checking oscillation circuit

- ① Some ICs have a low upper-limit value of usable frequency, so refer to individual IC catalog to make sure that the IC can oscillate a crystal unit with an adequate negative resistance.
- ② The following figure shows an example of a CMOS oscillation circuit. Check resistance R_{sup} is connected in series with the crystal unit to check the negative resistance. Use 3 to 22pF for C_1 and C_2 , and see the table below for values of check resistance.

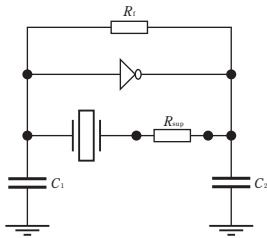

Frequency range	Values of check resistance
3.5 to 4.5MHz	1.5kΩ
4.6 to 6.0MHz	1.0kΩ
6.1 to 10.0MHz	800Ω
10.1 to 14.0MHz	500Ω
14.1 to 20.0MHz	400Ω

- ③ Using a spectrum analyzer or oscilloscope, check that every oscillation is normally activated while turning the power on and off several times. For oscillation circuits with no power regulator ICs, carefully check changes in the negative resistance against supply voltage and in frequencies.
- ④ When oscillation is normal, remove the check resistance before using the crystal circuit.
- ⑤ If oscillation is unstable or is not generated, gradually decrease the values of C_1 and C_2 until normal oscillation is obtained.
- ⑥ If normal oscillation cannot be generated near 10MHz or near 20MHz, replace the IC with a new one suitable for higher frequencies.

(6) Load capacitance and oscillation frequency of transistor/fundamental crystal oscillation circuit

Viewed from the connection terminals of a crystal unit, the load capacitance C_L of an oscillation circuit is generally comprised of C_1 , C_t , C_2 , and C_3 if stray capacitance of the circuit and the capacitance between base and emitter of the transistor are ignored. Since trimmer capacitor is adjusted to $C_T = \text{MIN. to MAX.}$ for zero adjustment of the oscillation frequency, the value of C_L at this time can be obtained from the following equation.

$$C_{L\text{MIN.}} = \left(\frac{1}{C_1 + C_T} + \frac{1}{C_2} + \frac{1}{C_3} \right)^{-1} \text{ to } C_{L\text{MAX.}} = \left(\frac{1}{C_1 + C_T} + \frac{1}{C_2} + \frac{1}{C_3} \right)^{-1}$$

When these calculation results are substituted for the following equation for load resonance frequency, the oscillation frequency can be obtained.

$$f_L = f_s \left(\frac{C_1}{2 \cdot (C_0 + C_L)} + 1 \right)$$

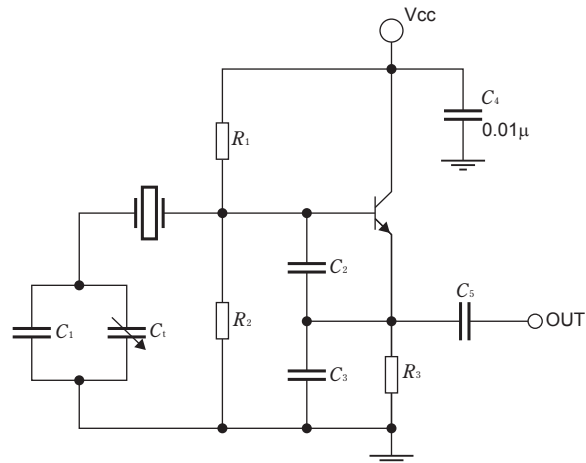

Select each circuit constant so that the adjustment ranges of upper and lower frequencies of this circuit are even on the basis of the frequency of a single crystal unit measured using a specified load capacity, and that the margin of ± 8 to 10×10^{-6} of the room temperature deviation of the crystal unit can be reserved.

To prevent the decrease in the negative resistance, always connect the crystal unit to the base of the transistor. For transistors used for oscillation circuits, h_{fe} and f_T are important.

To obtain the large negative resistance with small current consumption, select a transistor for high frequency amplification with h_{fe} of over 250 and f_T of 1GHz or more.

(7) Transistor third overtone oscillation circuit

- ① The resonance circuit comprised of L_2 and C_3 is required on the emitter side for preventing fundamental mode crystal oscillation. Set the resonance frequency to a value higher than the intermediate between fundamental wave frequency and third overtone frequency.
- ② Use L_1 , referred to as an elongation coil, to connect the load capacitance of the oscillation circuit in series. R_1 prevents self-excited oscillation by L_1 . Since it is difficult in general to design the oscillation circuit having adequate negative resistance in the overtone oscillation frequency band, there are no other effective means of obtaining adequate oscillation margin except for preventing the increase of load resonance resistance R_L of the crystal unit.

R_L in the equation of load resonance resistance can be made equal to R_s by connecting C_L in series, or making it infinite, which prevents increase in the load resonance resistance.

$$R_L = R_1 \left(1 + \frac{C_0}{C_L} \right)^2$$

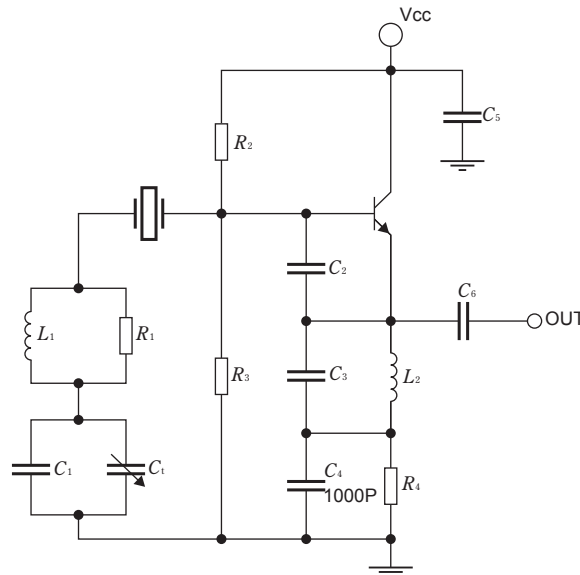

To prevent decrease in the negative resistance, connect the crystal unit to the base of the transistor as in the fundamental mode crystal oscillation circuit. To use the crystal circuit for both oscillation and multiplication, connect a parallel resonance circuit having multiplication frequency as resonance frequency to the collector of the transistor.

When selecting circuit constants for zero adjustment range by trimmer capacitor, set the constants to values obtained by adding approx. ± 12 to 15×10^{-6} to the room temperature deviation of the crystal unit, centering the value obtained by measuring the crystal unit with load capacitances in series. (When the room temperature deviation specification of the crystal unit is $\pm 10 \times 10^{-6}$)

(8) Excitation power of oscillation circuit

Normal operation of crystal units is not assured when excitation power is raised. The allowable excitation power varies depending on the shape of the crystal unit or the stability of targeted frequency. When highly accurate oscillation is required, however, it is recommended to use an oscillation circuit with an excitation power of 5 to 50 μ W or less. For other cases, refer to individual relevant crystal units on the pages of the catalog.

(9) Precautions for designing printed circuit board

Be sure to design printed circuit board patterns that connect a crystal unit with other oscillation elements so that the lengths of such patterns become shortest possible to prevent deterioration of characteristics due to stray capacitances and wiring inductance. For multi-layer circuit boards, it is important not to wire the ground and other signal patterns right beneath the oscillation circuit.

Tape & Reel Specifications

Crystal Units

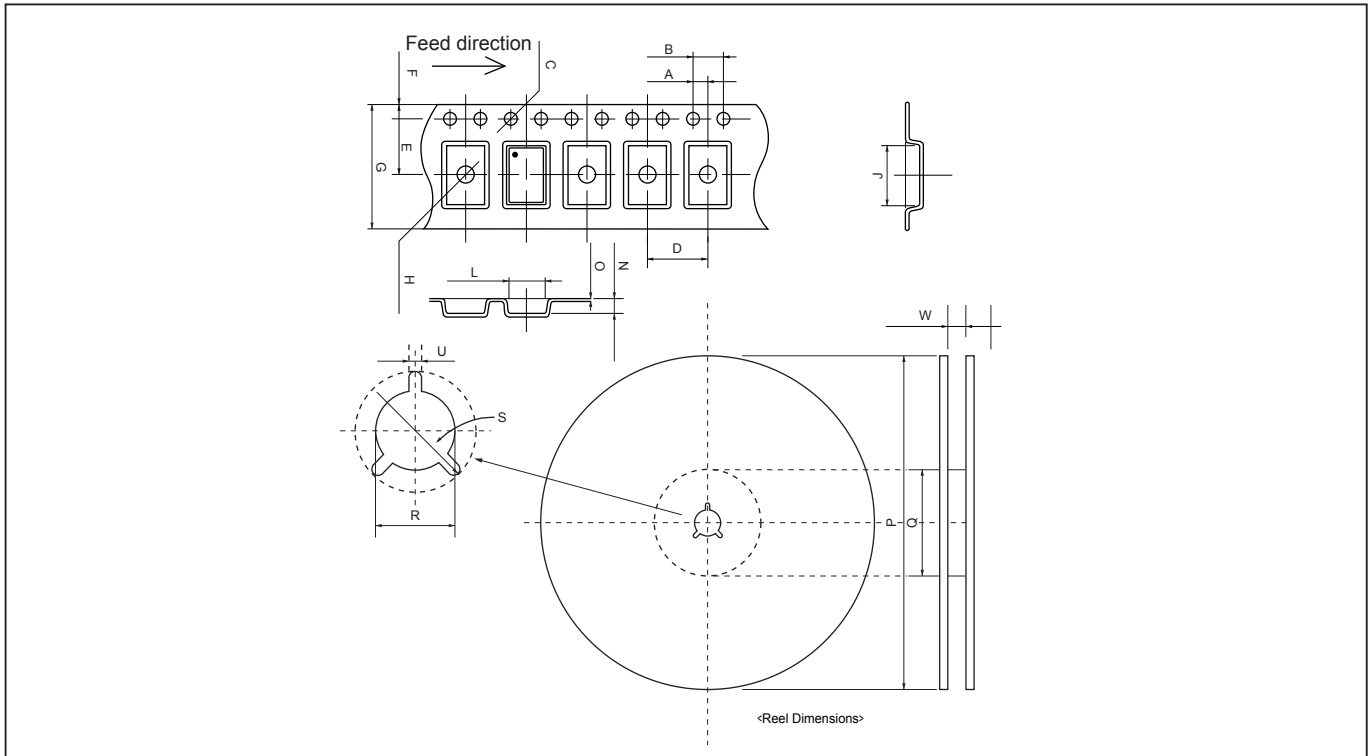

		CX2520SB (CX-2520SB)	CX3225SB (CX-101F)	CX4025SB (CX-4025S)	CX5032SB (CX-96F)	CX5032GB (CX-53F)	CX8045GB (CX-8045G) CX8045JA (CX-17F)	CXZ49FFA (CX-49F)	CX855GA (CX-5FW) CXB855GB (CX-5FD)	CXZ9LPA (CX-49L)
T A P E	A	2.0±0.05	2.0±0.05	2.0±0.1	2.0±0.1	2.0±0.1	2.0±0.1	2.0±0.1	2.0±0.1	2.0±0.1
	B	4.0±0.1	4.0±0.1	4.0±0.1	4.0±0.1	4.0±0.1	4.0±0.1	4.0±0.1	4.0±0.1	4.0±0.1
	C	φ1.55±0.05	φ1.55±0.05	φ1.55±0.05	φ1.5±0.1	φ1.55±0.1	φ1.5±0.1	φ1.55±0.05	φ1.55±0.05	φ1.5±0.1
	D	4.0±0.05	4.0±0.05	4.0±0.1	8.0±0.1	8.0±0.1	8.0±0.1	8.0±0.1	12.0±0.1	16.0±0.1
	E	3.5±0.05	3.5±0.05	5.5±0.1	5.5±0.1	5.5±0.1	7.5±0.1	11.5±0.1	11.5±0.1	11.5±0.1
	F	1.75±0.1	1.75±0.1	1.75±0.1	1.75±0.1	1.75±0.1	1.75±0.1	1.75±0.1	1.75±0.1	1.75±0.1
	G	8.0±0.2	8.0±0.2	12.0±0.3	12.0±0.3	12.0±0.2	16.0±0.3	24.0±0.3	24.0±0.3	24.0±0.3
	H	φ1.05±0.1	φ1.05±0.1	φ1.05±0.1	φ1.5±0.1	φ1.55±0.1	φ1.55±0.05	φ2.05±0.05	φ2.05±0.05	φ2.2±0.1
	J	3.5±0.1	3.5±0.1	4.2±0.1	5.5±0.1	5.4±0.1	8.4±0.1	11.5±0.1	12.2±0.1	—
	L	2.8±0.1	2.8±0.1	2.7±0.1	3.7±0.1	3.6±0.1	4.9±0.1	5.4±0.1	5.85±0.1	—
	N	0.85±0.1	0.85±0.1	0.95±0.05	1.4±0.1	1.7±0.1	2.1±0.1	5.5±0.1	2.8±0.1	6.5±0.1
O	0.25±0.05	0.25±0.05	0.2±0.05	0.3±0.05	0.25±0.05	0.3±0.05	0.3±0.05	0.3±0.05	0.5±0.05	
R E E L	P	φ180+0/-3	φ180+0/-3	φ180+0/-3	φ330±2/φ178±2	φ330±2/φ254±2	φ330±2/φ254±2	φ330±2	φ330±2	φ330±2
	Q	φ60+1/-0	φ60+1/-0	φ60+1/-0	φ80±2/φ100±1	φ100±1	φ80±1	φ100±1	φ100±1	φ100±1
	R	φ13±0.2	φ13±0.2	φ13±0.2	φ13±0.2	φ13±0.2	φ13±0.2	φ13±0.5	φ13±0.5	φ13±0.5
	S	φ21±0.8	φ21±0.8	φ21±0.8	φ21±0.8	φ21±0.8	φ21±0.8	φ21±0.5	φ21±0.5	—
	U	2.0±0.5	2.0±0.5	2.0±0.5	2.0±0.5	2.0±0.5	2.0±0.5	2.0±0.2	2.0±0.5	—
	W	9±1	9±1	13±1	13.5+1/-0.5	13.4+2/-0	16.0+2/-0	25.5±0.5	24.4+2/-0	25.5+1/-0.5
Qty		3000/1000	3000/1000	3000/1000	5000/1000	3000/1000	3000/1000	1000	1000	600



Pb Free

RoHS Compliant

Features

- Miniature ceramic package
- Highly reliable with seam welding
- CMOS output
- Supply voltage $V_{DD} = 1.8V$
Lower voltage available

Table 1

Freq. Tol. Code	Tol. $\times 10^{-6}$	Operating Temperature Range (°C)	Note
0	± 50	-10 to +70	Standard specifications
S	± 30		
U	± 25		
F	± 100	-40 to +85	With only certain frequencies
G	± 50		

How to Order

KC2520A 25.0000 C 1 0 E 00
 ① ② ③ ④ ⑤ ⑥ ⑦

- ① Type (2.5×2.0mm SMD)
- ② Output Frequency
- ③ Output Type (CMOS)
- ④ Supply Voltage (1.8V)
- ⑤ Frequency Tolerance (See Table 1)
- ⑥ Symmetry/Enable Function (45/55%, Stand-by)
- ⑦ Customer Special Model Suffix (STD Specification is "00")

Packaging (Tape & Reel 2000pcs./reel)

Specifications

Item	Symbol	Conditions	Min.	Max.	Units	
Output Frequency Range	Fo		1.5	50	MHz	
Frequency Tolerance	F _{tol}	Initial tolerance, Operating temperature range, Rated power supply voltage change, Load change, Aging (1year @25°C), Shock and vibration	Op. Temp.: -40 to +85°C	-100	+100	$\times 10^{-6}$
			Op. Temp.: -10 to +70°C / -40 to +85°C	-50	+50	
			Op. Temp.: -10 to +70°C / -40 to +85°C	-30	+30	
			Op. Temp.: -10 to +70°C	-25	+25	
Storage Temperature Range	T _{stg}		-55	+125	°C	
Operating Temperature Range	T _{use}	Standard Specifications	-10	+70	°C	
		Extend (Option)	-40	+85		
Max. Supply Voltage	—		-0.5	+7.0	V	
Supply Voltage	V _{DD}	Freq. Tol.Code: 0, S, F	1.62	1.98	V	
		Freq. Tol.Code: U, G	1.71	1.89		
Current Consumption (Maximum Loaded)	I _{DD}	1.5 ≤ Fo ≤ 24MHz	—	3	mA	
		24 < Fo ≤ 40MHz	—	4		
		40 < Fo ≤ 50MHz	—	5		
Stand-by Current	I _{std}		—	10	μA	
Symmetry	SYM	@50% V _{DD}	45	55	%	
Rise/ Fall Time (10% V _{DD} to 90% V _{DD} Maximum Loaded)	Tr/Tf	1.8 ≤ Fo ≤ 26MHz	—	9	nS	
		26 < Fo ≤ 50MHz	—	7		
Output Voltage-"L"	V _{OL}	I _{OL} = 2mA	—	10% V _{DD}	V	
Output Voltage-"H"	V _{OH}	I _{OH} = -2mA	90% V _{DD}	—	V	
Output Load	L _{CMOS}	CMOS Output	—	15	pF	
Input Voltage Range	V _{IN}		0	V _{DD}	V	
Input Voltage-"L"	V _{IL}		—	30% V _{DD}	V	
Input Voltage-"H"	V _{IH}		70% V _{DD}	—	V	
Disable Time	—		—	100	nS	
Enable Time	—		—	3	mS	
Start-up Time	ST	@ Minimum operation voltage to be 0 sec.	—	10	mS	

Note: All electrical characteristics are defined at the maximum load and operating temperature range.
 Please contact us for inquiries about operating temperature range, available frequencies and other conditions.

Dimensions

(Unit : mm)

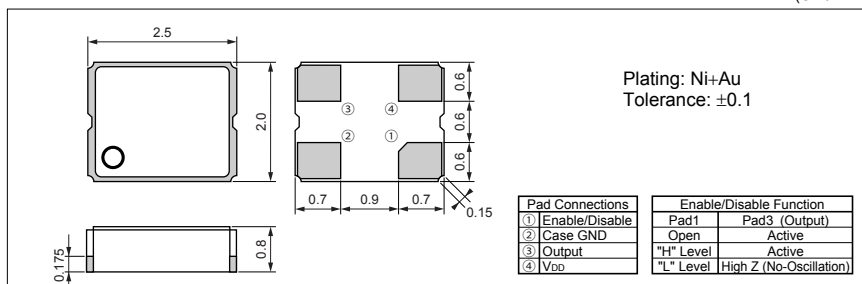

Recommended Land Pattern

(Unit : mm)

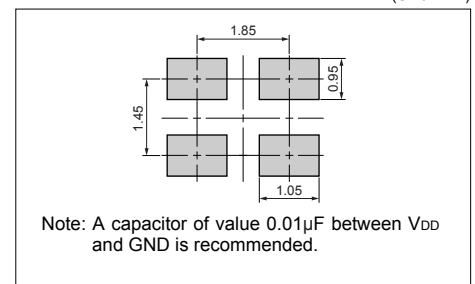



Pb-free

RoHS Compliant

Features

- Miniature ceramic package
- Highly reliable with seam welding
- CMOS output
- Supply voltage $V_{DD} = 2.5V$
Lower voltage available

How to Order

KC2520A 25.0000 C 2 0 E 00
① ② ③ ④ ⑤ ⑥ ⑦

- ① Type (2.5x2.0mm SMD)
- ② Output Frequency
- ③ Output Type (CMOS)
- ④ Supply Voltage (2.5V)
- ⑤ Frequency Tolerance (See Table 1)
- ⑥ Symmetry/Enable Function (45/55%, Stand-by)
- ⑦ Customer Special Model Suffix (STD Specification is "00")

Packaging (Tape & Reel 2000pcs./reel)

Table 1

Freq. Tol. Code	Tol. $\times 10^{-6}$	Operating Temperature Range (°C)	Note
0	± 50	-10 to +70	Standard specifications
S	± 30		
U	± 25		
F	± 100	-40 to +85	With only certain frequencies
G	± 50		

Specifications

Item	Symbol	Conditions	Min.	Max.	Units	
Output Frequency Range	Fo		1.5	50	MHz	
Frequency Tolerance	F _{tol}	Initial tolerance, Operating temperature range, Rated power supply voltage change, Load change, Aging (1year @25°C), Shock and vibration	Op. Temp.: -40 to +85°C	-100	+100	$\times 10^{-6}$
			Op. Temp.: -10 to +70°C / -40 to +85°C	-50	+50	
			Op. Temp.: -10 to +70°C / -40 to +85°C	-30	+30	
			Op. Temp.: -10 to +70°C	-25	+25	
Storage Temperature Range	T _{stg}		-55	+125	°C	
Operating Temperature Range	T _{use}	Standard Specifications	-10	+70	°C	
		Extend (Option)	-40	+85		
Max. Supply Voltage	—		-0.5	+7.0	V	
Supply Voltage	V _{DD}	Freq. Tol.Code: 0, S, F	2.25	2.75	V	
		Freq. Tol.Code: U, G	2.38	2.63		
Current Consumption (Maximum Loaded)	I _{DD}	1.5 ≤ Fo ≤ 24MHz	—	4	mA	
		24 < Fo ≤ 40MHz	—	5		
		40 < Fo ≤ 50MHz	—	6		
Stand-by Current	I _{std}		—	10	μA	
Symmetry	SYM	@50% V _{DD}	45	55	%	
Rise/ Fall Time (10% V_{DD} to 90% V_{DD} Maximum Loaded)	Tr/Tf	1.8 ≤ Fo ≤ 26MHz	—	8	nS	
		26 < Fo ≤ 50MHz	—	6		
Output Voltage-"L"	V _{OL}	I _{OL} =5mA	—	10% V _{DD}	V	
Output Voltage-"H"	V _{OH}	I _{OH} =-5mA	90% V _{DD}	—	V	
Output Load	L _{CMOS}	CMOS Output	—	15	pF	
Input Voltage Range	V _{IN}		0	V _{DD}	V	
Input Voltage-"L"	V _{IL}		—	30% V _{DD}	V	
Input Voltage-"H"	V _{IH}		70% V _{DD}	—	V	
Disable Time	—		—	100	nS	
Enable Time	—		—	3	mS	
Start-up Time	ST	@ Minimum operation voltage to be 0 sec.	—	10	mS	

Note: All electrical characteristics are defined at the maximum load and operating temperature range.
Please contact us for inquiries about operating temperature range, available frequencies and other conditions.

Dimensions

(Unit : mm)

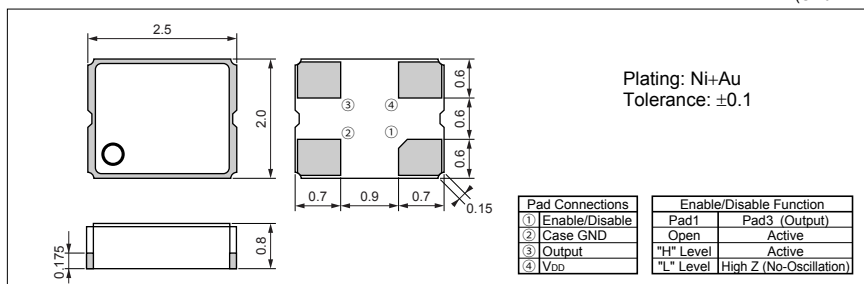

Recommended Land Pattern

(Unit : mm)

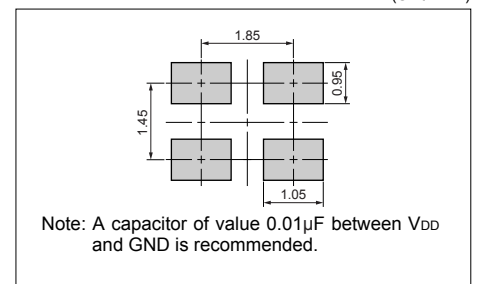



Pb-free

RoHS Compliant

Features

- Miniature ceramic package
- Highly reliable with seam welding
- CMOS output
- Supply voltage $V_{DD} = 3.3V$

How to Order

KC2520A 25.0000 C 3 0 E 00
 ① ② ③ ④ ⑤ ⑥ ⑦

- ① Type (2.5×2.0mm SMD)
- ② Output Frequency
- ③ Output Type (CMOS)
- ④ Supply Voltage (3.3V)
- ⑤ Frequency Tolerance (See Table 1)
- ⑥ Symmetry/Enable Function (45/55%, Stand-by)
- ⑦ Customer Special Model Suffix (STD Specification is "00")

Packaging (Tape & Reel 2000pcs./reel)

Table 1

Freq. Tol. Code	Tol. $\times 10^{-6}$	Operating Temperature Range (°C)	Note
0	± 50	-10 to +70	Standard specifications
S	± 30		
U	± 25		
F	± 100	-40 to +85	With only certain frequencies
G	± 50		

Specifications

Item	Symbol	Conditions	Min.	Max.	Units	
Output Frequency Range	Fo		1.5	50	MHz	
Frequency Tolerance	F _{tol}	Initial tolerance, Operating temperature range, Rated power supply voltage change, Load change, Aging (1year @25°C), Shock and vibration	Op. Temp.: -40 to +85°C	-100	+100	$\times 10^{-6}$
			Op. Temp.: -10 to +70°C / -40 to +85°C	-50	+50	
			Op. Temp.: -10 to +70°C / -40 to +85°C	-30	+30	
			Op. Temp.: -10 to +70°C	-25	+25	
Storage Temperature Range	T _{stg}		-55	+125	°C	
Operating Temperature Range	T _{use}	Standard Specifications	-10	+70	°C	
		Extend (Option)	-40	+85		
Max. Supply Voltage	—		-0.5	+7.0	V	
Supply Voltage	V _{DD}	Freq. Tol.Code: 0, S, F	2.97	3.63	V	
		Freq. Tol.Code: U, G	3.14	3.46		
Current Consumption (Maximum Loaded)	I _{DD}	1.5 ≤ Fo ≤ 24MHz	—	5	mA	
		24 < Fo ≤ 40MHz	—	6		
		40 < Fo ≤ 50MHz	—	8		
Stand-by Current	I _{std}		—	10	μA	
Symmetry	SYM	@50% V _{DD}	45	55	%	
Rise/ Fall Time (10% V _{DD} to 90% V _{DD} Maximum Loaded)	Tr/Tf	1.8 ≤ Fo ≤ 26MHz	—	8	nS	
		26 < Fo ≤ 50MHz	—	6		
Output Voltage-"L"	V _{OL}	I _{OL} =6mA	—	10% V _{DD}	V	
Output Voltage-"H"	V _{OH}	I _{OH} =-6mA	90% V _{DD}	—	V	
Output Load	L _{CMOS}	CMOS Output	—	15	pF	
Input Voltage Range	V _{IN}		0	V _{DD}	V	
Input Voltage-"L"	V _{IL}		—	30% V _{DD}	V	
Input Voltage-"H"	V _{IH}		70% V _{DD}	—	V	
Disable Time	—		—	100	nS	
Enable Time	—		—	3	mS	
Start-up Time	ST	@ Minimum operation voltage to be 0 sec.	—	10	mS	

Note: All electrical characteristics are defined at the maximum load and operating temperature range.
 Please contact us for inquiries about operating temperature range, available frequencies and other conditions.

Dimensions

(Unit : mm)

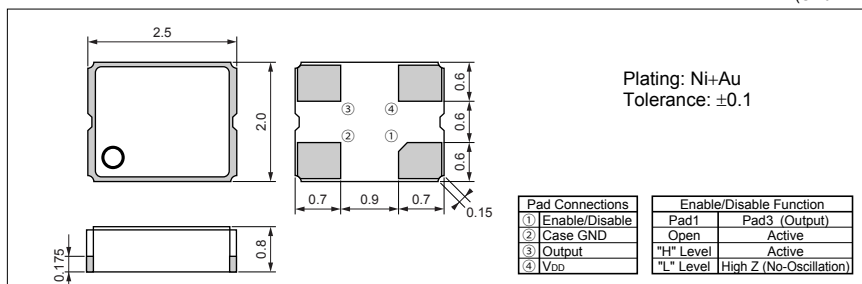

Recommended Land Pattern

(Unit : mm)

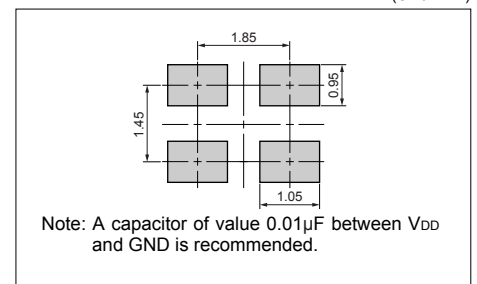



Pb-free

RoHS Compliant

Features

- Miniature ceramic package
- Highly reliable with seam welding
- CMOS output
- Supply voltage $V_{DD} = 2.5V$
Lower voltage available
- $\pm 25 \times 10^{-6}$ available

Table 1

Freq. Tol. Code	Tol. $\times 10^{-6}$	Operating Temperature Range (°C)	Note
0	± 50	-10 to +70	Standard specifications
S	± 30		
U	± 25		
F	± 100	-40 to +85	With only certain frequencies
G	± 50		

How to Order

KC3225A 25.0000 C 2 0 E 00
 ① ② ③ ④ ⑤ ⑥ ⑦

- ① Type (3.2×2.5mm SMD)
- ② Output Frequency
- ③ Output Type (CMOS)
- ④ Supply Voltage (2.5V)
- ⑤ Frequency Tolerance (See Table 1)
- ⑥ Symmetry/Enable Function (45/55%, Stand-by)
- ⑦ Customer Special Model Suffix (STD Specification is "00")

Packaging (Tape & Reel 2000pcs./reel)

Specifications

Item	Symbol	Conditions	Min.	Max.	Units	
Output Frequency Range	Fo		1.5	125	MHz	
Frequency Tolerance	F _{tol}	Initial tolerance, Operating temperature range, Rated power supply voltage change, Load change, Aging (1year @25°C), Shock and vibration	Op. Temp.: -40 to +85°C	-100	+100	$\times 10^{-6}$
			Op. Temp.: -10 to +70°C / -40 to +85°C	-50	+50	
			Op. Temp.: -10 to +70°C / -40 to +85°C	-30	+30	
			Op. Temp.: -10 to +70°C	-25	+25	
Storage Temperature Range	T _{stg}		-55	+125	°C	
Operating Temperature Range	T _{use}	Standard Specifications	-10	+70	°C	
		Extend (Option)	-40	+85		
Max. Supply Voltage	—		-0.5	+7.0	V	
Supply Voltage	V _{DD}	Freq. Tol.Code: 0, S, F	2.25	2.75	V	
		Freq. Tol.Code: U, G	2.38	2.63		
Current Consumption (Maximum Loaded)	I _{DD}	1.5 ≤ Fo ≤ 26MHz	—	4	mA	
		26 < Fo ≤ 50MHz	—	6		
		50 < Fo ≤ 68MHz	—	9		
		68 < Fo ≤ 90MHz	—	12		
		90 < Fo ≤ 125MHz	—	18		
Stand-by Current	I _{std}		—	10	μA	
Symmetry	SYM	@50% V _{DD}	45	55	%	
Rise/ Fall Time (10% V _{DD} to 90% V _{DD} Maximum Loaded)	Tr/Tf	1.5 ≤ Fo ≤ 68MHz	—	6	nS	
		68 < Fo ≤ 90MHz	—	5		
		90 < Fo ≤ 125MHz	—	4		
Output Voltage-"L"	V _{OL}	I _{OL} =4mA	—	10% V _{DD}	V	
Output Voltage-"H"	V _{OH}	I _{OH} =-4mA	90% V _{DD}	—	V	
Output Load	L _{CMOS}	CMOS Output	—	15	pF	
Input Voltage Range	V _{IN}		0	V _{DD}	V	
Input Voltage-"L"	V _{IL}		—	30% V _{DD}	V	
Input Voltage-"H"	V _{IH}		70% V _{DD}	—	V	
Disable Time	—		—	150	nS	
Enable Time	—		—	5	mS	
Start-up Time	ST	@ Minimum operation voltage to be 0 sec.	—	10	mS	

Note: All electrical characteristics are defined at the maximum load and operating temperature range.
 Please contact us for inquiries about operating temperature range, available frequencies and other conditions.

Dimensions

(Unit : mm)

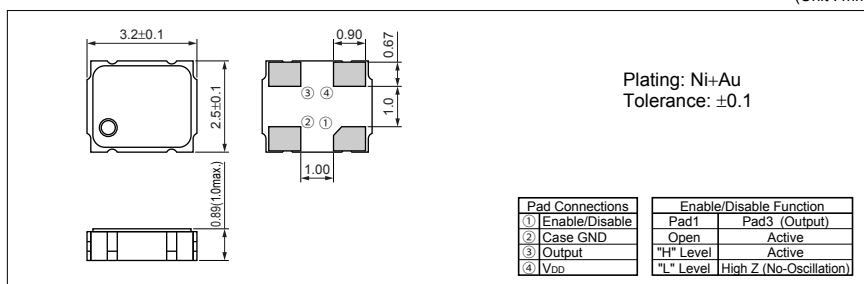

Recommended Land Pattern

(Unit : mm)

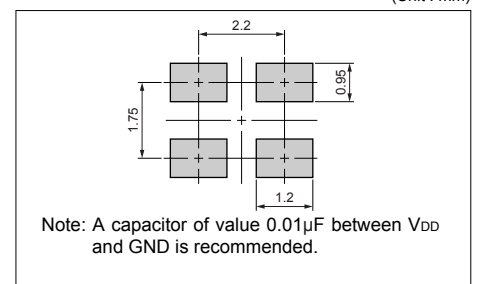

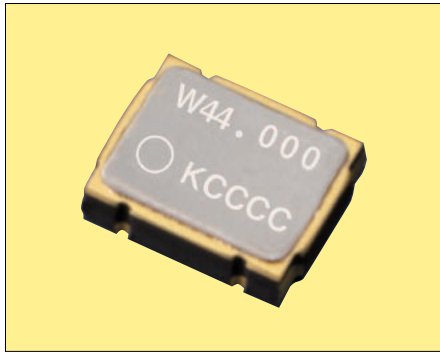

Pb-free

RoHS Compliant

Features

- Miniature ceramic package
- Highly reliable with seam welding
- CMOS output
- Supply voltage $V_{DD} = 3.3V$
- $\pm 25 \times 10^{-6}$ available

Table 1

Freq. Tol. Code	Freq. Tol. $\times 10^{-6}$	Operating Temperature Range (°C)	Note
0	± 50	-10 to +70	Standard specifications
S	± 30		
U	± 25	-40 to +85	With only certain frequencies
F	± 100		
G	± 50		

How to Order

KC3225A 25.0000 C 3 0 E 00
 ① ② ③ ④ ⑤ ⑥ ⑦

- ① Type (3.2×2.5mm SMD)
- ② Output Frequency
- ③ Output Type (CMOS)
- ④ Supply Voltage (3.3V)
- ⑤ Frequency Tolerance (See Table 1)
- ⑥ Symmetry/Enable Function (45/55%, Stand-by)
- ⑦ Customer Special Model Suffix (STD Specification is "00")

Packaging (Tape & Reel 2000pcs./reel)

Specifications

Item	Symbol	Conditions	Min.	Max.	Units	
Output Frequency Range	Fo		1.5	125	MHz	
Frequency Tolerance	F _{tol}	Initial tolerance, Operating temperature range, Rated power supply voltage change, Load change, Aging (1year @25°C), Shock and vibration	Op. Temp.: -40 to +85°C	-100	+100	$\times 10^{-6}$
			Op. Temp.: -10 to +70°C/ -40 to +85°C	-50	+50	
			Op. Temp.: -10 to +70°C/ -40 to +85°C	-30	+30	
			Op. Temp.: -10 to +70°C	-25	+25	
Storage Temperature Range	T _{stg}		-55	+125	°C	
Operating Temperature Range	T _{use}	Standard Specifications	-10	+70	°C	
		Extend (Option)	-40	+85		
Max. Supply Voltage	—		-0.5	+7.0	V	
Supply Voltage	V _{DD}	Freq. Tol.Code: 0, S, F	2.97	3.63	V	
		Freq. Tol.Code: U, G	3.14	3.46		
Current Consumption (Maximum Loaded)	I _{DD}	1.5 ≤ Fo ≤ 26MHz	—	6	mA	
		26 < Fo ≤ 50MHz	—	8		
		50 < Fo ≤ 68MHz	—	12		
		68 < Fo ≤ 90MHz	—	18		
		90 < Fo ≤ 125MHz	—	25		
Stand-by Current	I _{std}		—	10	μA	
Symmetry	SYM	@50% V _{DD}	45	55	%	
Rise/ Fall Time (10% V _{DD} to 90% V _{DD} Maximum Loaded)	Tr/Tf	1.5 ≤ Fo ≤ 68MHz	—	5	nS	
		68 < Fo ≤ 90MHz	—	4		
		90 < Fo ≤ 125MHz	—	3		
Output Voltage-"L"	V _{OL}	I _{OL} =4mA	—	10% V _{DD}	V	
Output Voltage-"H"	V _{OH}	I _{OH} =-4mA	90% V _{DD}	—	V	
Output Load	L _{CMOS}	CMOS Output	—	15	pF	
Input Voltage Range	V _{IN}		0	V _{DD}	V	
Input Voltage-"L"	V _{IL}		—	30% V _{DD}	V	
Input Voltage-"H"	V _{IH}		70% V _{DD}	—	V	
Disable Time	—		—	150	nS	
Enable Time	—		—	5	mS	
Start-up Time	ST	@ Minimum operation voltage to be 0 sec.	—	10	mS	

Note: All electrical characteristics are defined at the maximum load and operating temperature range.
 Please contact us for inquiries about operating temperature range, available frequencies and other conditions.

Dimensions

(Unit : mm)

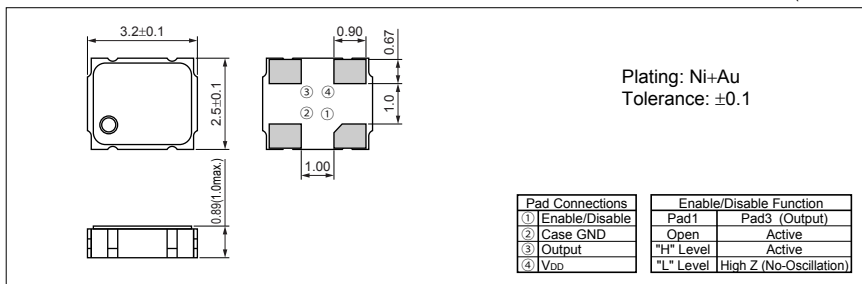

Recommended Land Pattern

(Unit : mm)

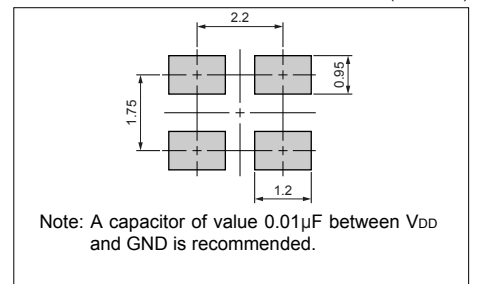



Pb Free

RoHS Compliant

Features

- Miniature ceramic package
- Highly reliable with seam welding
- CMOS output
- Supply voltage $V_{DD} = 1.8V$
Lower voltage available
- $\pm 25 \times 10^{-6}$, $\pm 20 \times 10^{-6}$ available

Table 1

Freq. Tol. Code	Tol. $\times 10^{-6}$	Operating Temperature Range (°C)	Note
0	± 50	-10 to +70	Standard specifications
S	± 30		
U	± 25		
W	± 20	-40 to +85	With only certain frequencies
F	± 100		
G	± 50		

How to Order

KC5032C 25.0000 C 1 0 E 00
 ① ② ③ ④ ⑤ ⑥ ⑦

- ① Type (5.0×3.2mm SMD)
- ② Output Frequency
- ③ Output Type (CMOS)
- ④ Supply Voltage (1.8V)
- ⑤ Frequency Tolerance (See Table 1)
- ⑥ Symmetry/Enable Function (45/55%, Stand-by)
- ⑦ Customer Special Model Suffix (STD Specification is "00")

Packaging (Tape & Reel 1000pcs./reel)

Specifications

Item	Symbol	Conditions	Min.	Max.	Units	
Output Frequency Range	Fo		1.8	39.99	MHz	
Frequency Tolerance	F _{tol}	Initial tolerance, Operating temperature range, Rated power supply voltage change, Load change, Aging (1year @25°C), Shock and vibration	Op. Temp.: -40 to +85°C	-100	+100	$\times 10^{-6}$
			Op. Temp.: -10 to +70°C/ -40 to +85°C	-50	+50	
			Op. Temp.: -10 to +70°C/ -40 to +85°C	-30	+30	
			Op. Temp.: -10 to +70°C	-25	+25	
			Op. Temp.: -10 to +70°C	-20	+20	
Storage Temperature Range	T _{stg}		-55	+125	°C	
Operating Temperature Range	T _{use}	Standard Specifications	-10	+70	°C	
		Extend (Option)	-40	+85		
Max. Supply Voltage	—		-0.5	+3.6	V	
Supply Voltage	V _{DD}	Freq. Tol.Code: 0, S, F	1.71	1.89	V	
		Freq. Tol.Code: U, G, W	1.75	1.85		
Current Consumption (Maximum Loaded)	I _{DD}	1.8 ≤ Fo ≤ 25MHz	—	3	mA	
		25 < Fo ≤ 39.99MHz	—	4		
Stand-by Current	I _{std}		—	10	μA	
Symmetry	SYM	@50% V _{DD}	45	55	%	
Rise/ Fall Time (10% V_{DD} to 90% V_{DD} Maximum Loaded)	Tr/Tf		—	9	nS	
Output Voltage-"L"	V _{OL}	I _{OL} =2.8mA	—	10% V _{DD}	V	
Output Voltage-"H"	V _{OH}	I _{OH} =-2.8mA	90% V _{DD}	—	V	
Output Load	L _{CMOS}	CMOS Output	—	15	pF	
Input Voltage Range	V _{IN}		0	V _{DD}	V	
Input Voltage-"L"	V _{IL}		—	30% V _{DD}	V	
Input Voltage-"H"	V _{IH}		70% V _{DD}	—	V	
Disable Time	—		—	150	nS	
Enable Time	—		—	5	mS	
Start-up Time	ST	@ Minimum operation voltage to be 0 sec.	—	10	mS	

Note: All electrical characteristics are defined at the maximum load and operating temperature range.
 Please contact us for inquiries about operating temperature range, available frequencies and other conditions.

Dimensions

(Unit : mm)

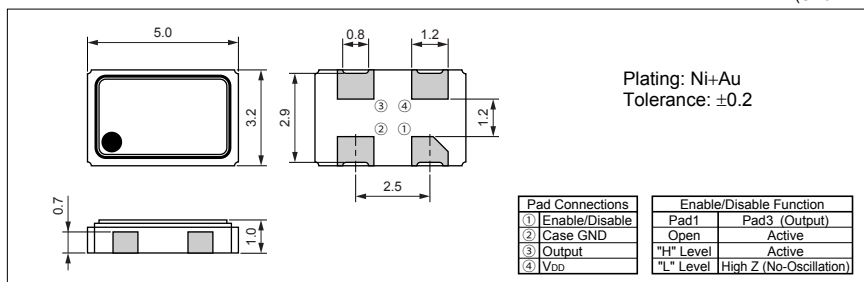

Recommended Land Pattern

(Unit : mm)

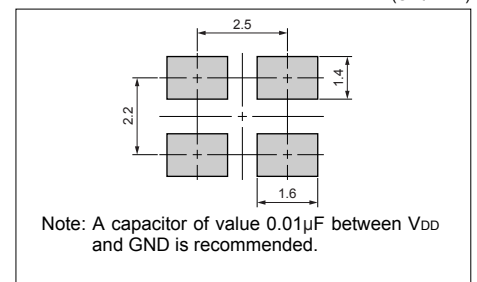



Pb Free

RoHS Compliant

Features

- Miniature ceramic package
- Highly reliable with seam welding
- CMOS output
- Supply voltage $V_{DD} = 2.5V$
Lower voltage available
- $\pm 25 \times 10^{-6}$, $\pm 20 \times 10^{-6}$ available

Table 1

Freq. Tol. Code	Tol. $\times 10^{-6}$	Operating Temperature Range (°C)	Note
0	± 50	-10 to +70	Standard specifications
S	± 30		
U	± 25		
W	± 20		
F	± 100	-40 to +85	With only certain frequencies
G	± 50		

How to Order

KC5032C 25.0000 C 2 0 E 00
 ① ② ③ ④ ⑤ ⑥ ⑦

- ① Type (5.0×3.2mm SMD)
- ② Output Frequency
- ③ Output Type (CMOS)
- ④ Supply Voltage (2.5V)
- ⑤ Frequency Tolerance (See Table 1)
- ⑥ Symmetry/Enable Function (45/55%, Stand-by)
- ⑦ Customer Special Model Suffix (STD Specification is "00")

Packaging (Tape & Reel 1000pcs./reel)

Specifications

Item	Symbol	Conditions	Min.	Max.	Units	
Output Frequency Range	Fo		1.8	125	MHz	
Frequency Tolerance	F _{tol}	Initial tolerance, Operating temperature range, Rated power supply voltage change, Load change, Aging (1year @25°C), Shock and vibration	Op. Temp.: -40 to +85°C	-100	+100	$\times 10^{-6}$
			Op. Temp.: -10 to +70°C/ -40 to +85°C	-50	+50	
			Op. Temp.: -10 to +70°C/ -40 to +85°C	-30	+30	
			Op. Temp.: -10 to +70°C	-25	+25	
Storage Temperature Range	T _{stg}		-55	+125	°C	
Operating Temperature Range	T _{use}	Standard Specifications	-10	+70	°C	
		Extend (Option)	-40	+85		
Max. Supply Voltage	—		-0.5	+7.0	V	
Supply Voltage	V _{DD}	Freq. Tol.Code: 0, S, F	2.25	2.75	V	
		Freq. Tol.Code: U, G	2.38	2.62		
		Freq. Tol.Code: W	2.43	2.57		
Current Consumption (Maximum Loaded)	I _{DD}	1.8<Fo≤20MHz	—	5	mA	
		20<Fo≤40MHz	—	10		
		40<Fo≤60MHz	—	15		
		60<Fo≤85MHz	—	20		
		85<Fo≤100MHz	—	22		
Stand-by Current	I _{std}		—	10	μA	
Symmetry	SYM	@50% V _{DD}	45	55	%	
Rise/ Fall Time (10% V_{DD} to 90% V_{DD} Maximum Loaded)	Tr/Tf	1.8<Fo≤40MHz	—	7	nS	
		40<Fo≤85MHz	—	4		
		85<Fo≤125MHz	—	3		
Output Voltage-"L"	V _{OL}	I _{OL} =4mA/8mA (40MHz<Fo)	—	10% V _{DD}	V	
Output Voltage-"H"	V _{OH}	I _{OH} =-4mA/-8mA (40MHz<Fo)	90% V _{DD}	—	V	
Output Load	L _{CMOS}	CMOS	—	15	pF	
Input Voltage Range	V _{IN}		0	V _{DD}	V	
Input Voltage-"L"	V _{IL}		—	30% V _{DD}	V	
Input Voltage-"H"	V _{IH}		70% V _{DD}	—	V	
Disable Time	—		—	150	nS	
Enable Time	—		—	5	mS	
Start-up Time	ST	@ Minimum operation voltage to be 0 sec.	—	10	mS	

Note: All electrical characteristics are defined at the maximum load and operating temperature range.
 Please contact us for inquiries about operating temperature range, available frequencies and other conditions.

Dimensions

(Unit : mm)

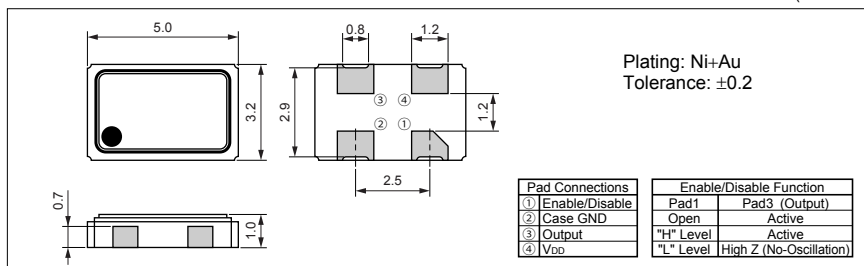

Recommended Land Pattern

(Unit : mm)

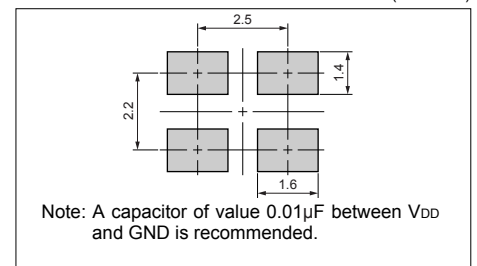



Pb Free

RoHS Compliant

Features

- Miniature ceramic package
- Highly reliable with seam welding
- CMOS output
- Supply voltage $V_{DD} = 3.3V$
- $\pm 25 \times 10^{-6}$, $\pm 20 \times 10^{-6}$ available

Table 1

Freq. Tol. Code	Tol. $\times 10^{-6}$	Operating Temperature Range (°C)	Note
0	± 50	-10 to +70	Standard specifications
S	± 30		
U	± 25		
W	± 20		
F	± 100	-40 to +85	With only certain frequencies
G	± 50		

How to Order

KC5032C 25.0000 C 3 0 E 00
 ① ② ③ ④ ⑤ ⑥ ⑦

- ① Type (5.0×3.2mm SMD)
- ② Output Frequency
- ③ Output Type (CMOS)
- ④ Supply Voltage (3.3V)
- ⑤ Frequency Tolerance (See Table 1)
- ⑥ Symmetry/Enable Function (45/55%, Stand-by)
- ⑦ Customer Special Model Suffix (STD Specification is "00")

Packaging (Tape & Reel 1000pcs./reel)

Specifications

Item	Symbol	Conditions	Min.	Max.	Units	
Output Frequency Range	Fo		1.8	160	MHz	
Frequency Tolerance	F _{tol}	Initial tolerance, Operating temperature range, Rated power supply voltage change, Load change, Aging (1year @25°C), Shock and vibration	Op. Temp.: -40 to +85°C	-100	+100	$\times 10^{-6}$
			Op. Temp.: -10 to +70°C / -40 to +85°C	-50	+50	
			Op. Temp.: -10 to +70°C / -40 to +85°C	-30	+30	
			Op. Temp.: -10 to +70°C	-25	+25	
			Op. Temp.: -10 to +70°C	-20	+20	
Storage Temperature Range	T _{stg}		-55	+125	°C	
Operating Temperature Range	T _{use}	Standard Specifications	-10	+70	°C	
		Extend (Option)	-40	+85		
Max. Supply Voltage	—		-0.5	+7.0	V	
Supply Voltage	V _{DD}	Freq. Tol.Code: 0, S, F	2.97	3.63	V	
		Freq. Tol.Code: U, G	3.14	3.46		
		Freq. Tol.Code: W	3.20	3.40		
Current Consumption (Maximum Loaded)	I _{DD}	1.8 ≤ Fo ≤ 20MHz	—	10	mA	
		20 < Fo ≤ 40MHz	—	15		
		40 < Fo ≤ 60MHz	—	30		
		60 < Fo ≤ 100MHz	—	35		
		100 < Fo ≤ 135MHz	—	45		
		135 < Fo ≤ 160MHz	—	60		
Stand-by Current	I _{std}		—	10	μA	
Symmetry	SYM	@50% V _{DD}	45	55	%	
Rise/ Fall Time (10% V _{DD} to 90% V _{DD} Maximum Loaded)	Tr/Tf	1.8 ≤ Fo ≤ 26MHz	—	10	nS	
		26 < Fo ≤ 45MHz	—	8		
		45 < Fo ≤ 100MHz	—	5		
		100 < Fo ≤ 160MHz	—	2.5		
Output Voltage-"L"	V _{OL}	I _{OL} =8mA	—	10% V _{DD}	V	
Output Voltage-"H"	V _{OH}	I _{OH} =-8mA	90% V _{DD}	—	V	
Output Load	L _{CMOS}	CMOS Output	—	15	pF	
Input Voltage Range	V _{IN}		0	V _{DD}	V	
Input Voltage-"L"	V _{IL}		—	30% V _{DD}	V	
Input Voltage-"H"	V _{IH}		70% V _{DD}	—	V	
Disable Time	—		—	150	nS	
Enable Time	—		—	5	mS	
Start-up Time	ST	@ Minimum operation voltage to be 0 sec.	—	10	mS	

Note: All electrical characteristics are defined at the maximum load and operating temperature range.
 Please contact us for inquiries about operating temperature range, available frequencies and other conditions.

Dimensions

(Unit : mm)

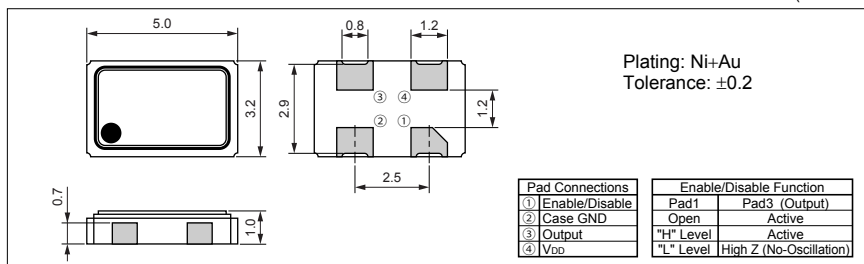

Recommended Land Pattern

(Unit : mm)

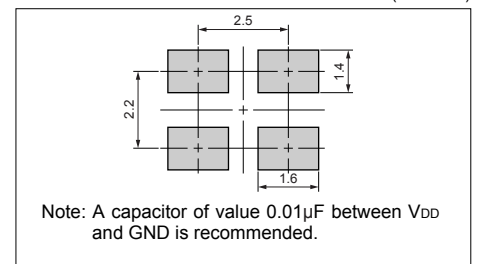



Pb Free

RoHS Compliant

Features

- Miniature ceramic package
- Highly reliable with seam welding
- CMOS output CL=50pF max available
- Supply voltage V_{DD} =3.3V

Table 1

Freq. Tol. Code	Freq. Tol. × 10 ⁻⁶	Operating Temperature Range (°C)	Note
0	± 50	-10 to +70	Standard specifications
S	± 30		With only certain frequencies

How to Order

KC5032C 25.0000 C 3 0 E HL
 ① ② ③ ④ ⑤ ⑥ ⑦

- ① Type (5.0x3.2mm SMD)
- ② Output Frequency
- ③ Output Type (CMOS)
- ④ Supply Voltage (3.3V)
- ⑤ Frequency Tolerance (See Table 1)
- ⑥ Symmetry/Enable Function (45/55%, Stand-by)
- ⑦ Heavy Load Type
 HL : CL =50pF max.

Packaging (Tape & Reel 1000pcs./reel)

Specifications

Item	Symbol	Conditions	Min.	Max.	Units	
Output Frequency Range	F _o		14	30	MHz	
Frequency Tolerance	F _{tol}	Initial tolerance, Operating temperature range, Rated power supply voltage change, Load change, Aging (1year @25°C), Shock and vibration	-50 -30	+50 +30	×10 ⁻⁶	
Storage Temperature Range	T _{stg}		-55	+125	°C	
Operating Temperature Range	T _{use}		-10	+70	°C	
Max. Supply Voltage	—		-0.5	+7.0	V	
Supply Voltage	V _{DD}	Freq. Tol.Code: 0, S	2.97	3.63	V	
Current Consumption (Maximum Loaded)	I _{DD}	CL=15pF CL=50pF	— —	10 15	mA	
Stand-by Current	I _{std}		—	10	μA	
Symmetry	SYM	@50% V _{DD}	CL=15pF	45	55	%
			CL=50pF	40	60	
Rise/ Fall Time (10% V _{DD} to 90% V _{DD} Maximum Loaded)	T _r /T _f	CL=15pF	—	5	nS	
		CL=50pF	—	8		
Output Voltage-"L"	V _{OL}	I _{OL} =8mA	—	10% V _{DD}	V	
Output Voltage-"H"	V _{OH}	I _{OH} =-8mA	90% V _{DD}	—	V	
Output Load	L _{CMOS}	CMOS Output	—	50	pF	
Input Voltage Range	V _{IN}		0	V _{DD}	V	
Input Voltage-"L"	V _{IL}		—	30% V _{DD}	V	
Input Voltage-"H"	V _{IH}		70% V _{DD}	—	V	
Disable Time	—		—	150	nS	
Enable Time	—		—	5	mS	
Start-up Time	ST	@ Minimum operation voltage to be 0 sec.	—	10	mS	

Note: All electrical characteristics are defined at the maximum load and operating temperature range.
 Please contact us for inquiries about operating temperature range, available frequencies and other conditions.

Dimensions

(Unit : mm)

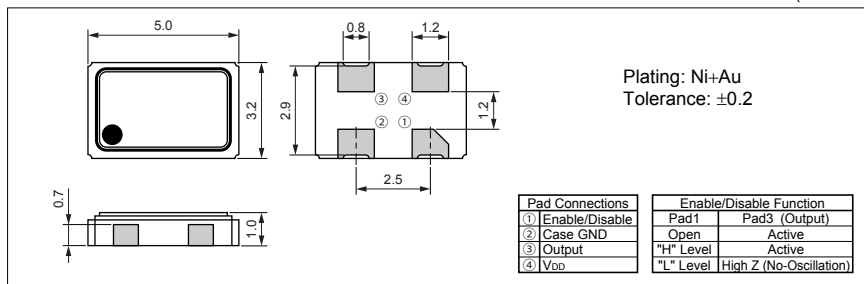

Recommended Land Pattern

(Unit : mm)

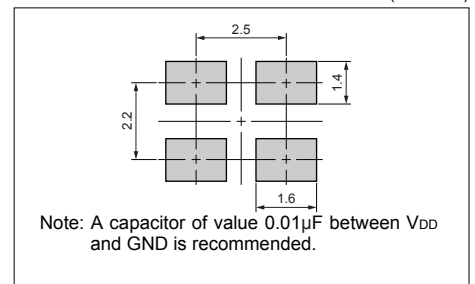



Pb Free

RoHS Compliant

Features

- Miniature ceramic package
- Highly reliable with seam welding
- CMOS output
- Supply voltage $V_{DD} = 5.0V$
- $\pm 25 \times 10^{-6}$ available

How to Order

KC5032C 25.0000 C 5 0 D 00
 ① ② ③ ④ ⑤ ⑥ ⑦

- ① Type (5.0×3.2mm SMD)
- ② Output Frequency
- ③ Output Type (CMOS)
- ④ Supply Voltage (5.0V)
- ⑤ Frequency Tolerance (See Table 1)
- ⑥ Symmetry/Enable Function (45/55%, Disable)
- ⑦ Customer Special Model Suffix (STD Specification is "00")

Packaging (Tape & Reel 1000pcs./reel)

Table 1

Freq. Tol. Code	Freq. Tol. $\times 10^{-6}$	Operating Temperature Range (°C)	Note
0	± 50	-10 to +70	Standard specifications
S	± 30		
U	± 25	-40 to +85	With only certain frequencies
F	± 100		
G	± 50		

Specifications

Item	Symbol	Conditions	Min.	Max.	Units	
Output Frequency Range	Fo		1.8	50	MHz	
Frequency Tolerance	F _{tol}	Initial tolerance, Operating temperature range, Rated power supply voltage change, Load change, Aging (1year @25°C), Shock and vibration	Op. Temp.: -40 to +85°C	-100	+100	$\times 10^{-6}$
			Op. Temp.: -10 to +70°C / -40 to +85°C	-50	+50	
			Op. Temp.: -10 to +70°C / -40 to +85°C	-30	+30	
			Op. Temp.: -10 to +70°C	-25	+25	
Storage Temperature Range	T _{stg}		-55	+125	°C	
Operating Temperature Range	T _{use}	Standard Specifications	-10	+70	°C	
		Extend (Option)	-40	+85		
Max. Supply Voltage	—		-0.5	+7.0	V	
Supply Voltage	V _{DD}	Freq. Tol.Code: 0, S, F	4.5	5.5	V	
		Freq. Tol.Code: U, G	4.75	5.25		
Current Consumption (Maximum Loaded)	I _{DD}	1.8 ≤ Fo ≤ 20MHz	—	25	mA	
		20 < Fo ≤ 40MHz	—	35		
		40 < Fo ≤ 50MHz	—	50		
Disable Current	I _{dis}		—	30	mA	
Symmetry	SYM	@50% V _{DD}	45	55	%	
Rise/ Fall Time (10% V _{DD} to 90% V _{DD} Maximum Loaded)	T _{Tr} /T _F	1.8 ≤ Fo ≤ 26MHz	—	10	nS	
		26 < Fo ≤ 50MHz	—	8		
Output Voltage-"L"	V _{OL}	I _{OL} = 16mA	—	10% V _{DD}	V	
Output Voltage-"H"	V _{OH}	I _{OH} = -16mA	90% V _{DD}	—	V	
Output Load	L _{CMOS}	CMOS Output	—	50	pF	
Input Voltage Range	V _{IN}		0	V _{DD}	V	
Input Voltage-"L"	V _{IL}		—	0.8	V	
Input Voltage-"H"	V _{IH}		2.2	—	V	
Disable Time	—		—	100	nS	
Enable Time	—		—	100	nS	
Start-up Time	ST	@ Minimum operation voltage to be 0 sec.	—	10	mS	

Note: All electrical characteristics are defined at the maximum load and operating temperature range.
 Please contact us for inquiries about operating temperature range, available frequencies and other conditions.

Dimensions

(Unit : mm)

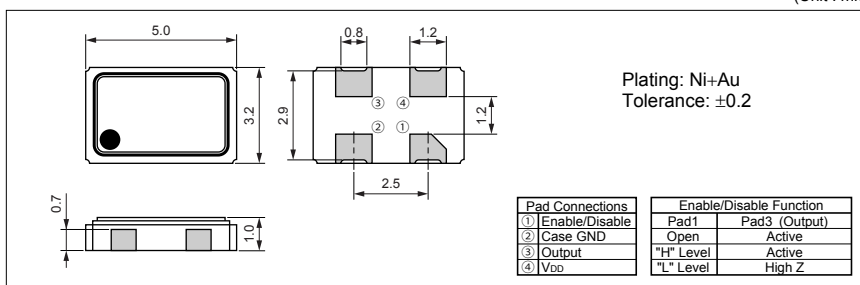

Recommended Land Pattern

(Unit : mm)

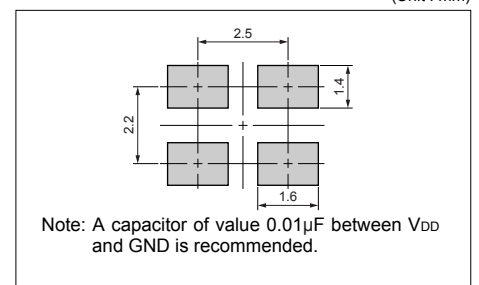



Pb Free

RoHS Compliant

Features

- Compact and low profile (5x3.2x1.2mm)
- Surface mount type suitable for auto pick-and-place
- Reflow soldering compatible
- CMOS, TTL IC direct drive is possible
- With tri-state function
- Supply voltage $V_{DD}=3.3 / 5.0V$ available

Frequency Tolerance (Overall)

Freq.Tol. Code	$\times 10^{-6}$	Operating Temperature Range(°C)	Notes
1	± 100	-10 to +70 (standard)	1.8 to 40MHz
0	± 50		
S	± 30		1.8 to 50MHz

How to Order

KC5032D 25.0000 C 3 0 A 00
 ① ② ③ ④ ⑤ ⑥ ⑦

- ① Type
- ② Output Frequency
- ③ Output Type (CMOS)
- ④ Supply Voltage 5=5.0V, 3=3.3V
- ⑤ Frequency Tolerance (See table at left)
- ⑥ Symmetry/Enable Function (40/60%, INH)
- ⑦ Customer Special Model Suffix (STD Specification is "00")

Specifications

Items	Symbol	Specifications		Units
		KC5032Dxx.xxxxC5xA00 (FXO-61F2)	KC5032Dxx.xxxxC3xA00 (FXO-61FL2)	
Output Frequency Range	F_0	1.8 to 50		MHz
Frequency Tolerance (Overall)	F_{tol}	± 30 (to 40MHz)		$\times 10^{-6}$
		± 50 (to 50MHz)		
		± 100		
Storage Temperature Range	T_{stg}	-40 to +85		°C
Operating Temperature Range	T_{use}	-10 to +70		°C
Max. Supply Voltage	-	7 Max.		V
Supply Voltage	V_{DD}	5 \pm 0.5	3.3 \pm 0.3	V
Current Consumption	I_{DD}	25 Max.	18 Max. (1.8 to 39.9MHz)	mA
			25 Max. (40 to 50MHz)	
Stand-by Current	I_{std}	10 Max.		μ A
Symmetry	SYM	40 to 60@50% V_{DD}		%
Rise / Fall Time	T_r/T_f	10 Max.		nS
Output Voltage-"L"	V_{OL}	10% V_{DD} Max.		V
Output Voltage-"H"	V_{OH}	90% V_{DD} Min.		V
Output Load	CL	15 Max.	20 Max.	pF
Input Voltage Range	V_{IN}	0 to V_{DD}	0 to V_{DD}	V
Input Voltage-"L"	V_{IL}	0.8 Max.	0.3 Max.	V
Input Voltage-"H"	V_{IH}	2.2 Min.	2.2 Min.	V
Disable Time	-	150 Max.		nS
Enable Time	-	5 Max.		mS
Start-up Time	ST	10 Max.		mS

Note: All electrical characteristics are defined at the maximum load and operating temperature range.
 Please contact us for inquires about operating temperature range, available frequencies and other conditions.

Dimensions

(Unit : mm)

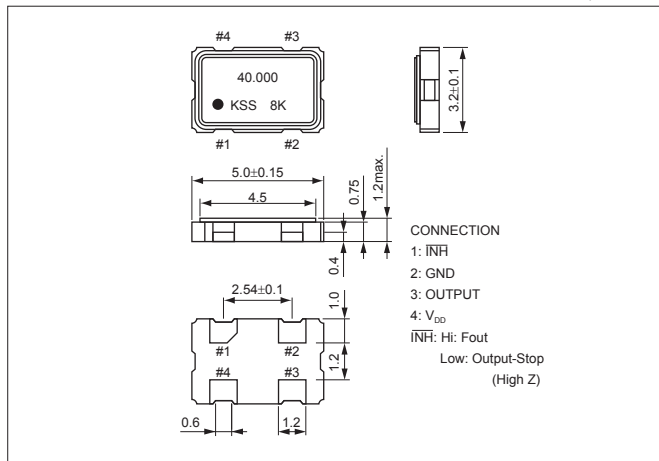

Recommended Land Pattern

(Unit : mm)

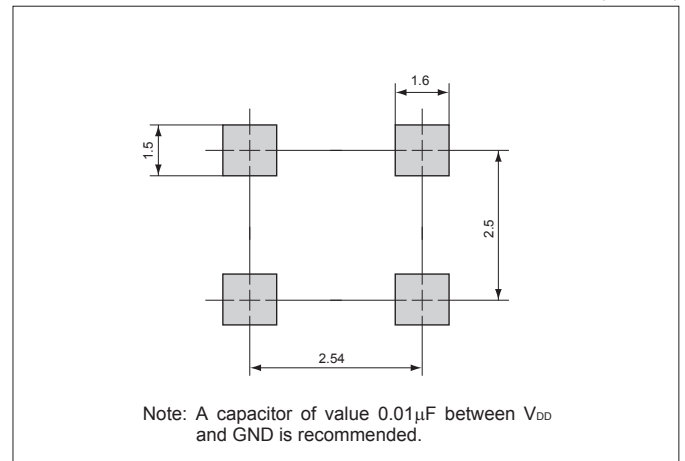



Pb Free

RoHS Compliant

Features

- A built-in high-precision CMOS IC suitable for a wide range of temperature
- Ideal for base stations and DSC, DVC, car navigation and PHS systems etc.
- Lower noise and lower current for reduced power consumption
- Supply voltage V_{DD} =3.3/5.0V available

Frequency Tolerance (Overall)

Freq.Tol. Code	$\times 10^{-6}$	Operating Temperature Range(°C)	Notes
P	± 100	-30 to +85 (Standard)	1.8 to 40MHz
Q	± 50		
R	± 30		

How to Order

KC5032D 15.3600 C 3 Q A 00
① ② ③ ④ ⑤ ⑥ ⑦

- ① Type
- ② Output Frequency
- ③ Output Type (CMOS)
- ④ Supply Voltage 5=5.0V, 3=3.3V
- ⑤ Frequency Tolerance
- ⑥ Symmetry/Enable Function (40/60%, INH)
- ⑦ Customer Special Model Suffix (STD Specification is "00")

Specifications

Items	Symbol	Specifications		Units
		KC5032Dxx.xxxxC5xA00 (FXO-64F2)	KC5032Dxx.xxxxC3xA00 (FXO-64FL2)	
Output Frequency Range	F_0	1.8 to 40		MHz
Frequency Tolerance (Overall)	F_{tol}	± 30		$\times 10^{-6}$
		± 50		
		± 100		
Storage Temperature Range	T_{stg}	-40 to +85		°C
Operating Temperature Range	T_{use}	-30 to +85		°C
Max. Supply Voltage	-	7 Max.		V
Supply Voltage	V_{DD}	5 \pm 5%	3.3 \pm 5%	V
Current Consumption	I_{DD}	12 Max.	10 Max.	mA
Stand-by Current	I_{std}	8 Max.		μ A
Symmetry	SYM	40 to 60@50% V_{DD}		%
Rise / Fall Time	T_r/T_f	12 Max.	16 Max.	nS
Output Voltage-"L"	V_{OL}	10% V_{DD} Max.		V
Output Voltage-"H"	V_{OH}	90% V_{DD} Min.		V
Output Load	CL	15 Max.		pF
Input Voltage Range	V_{IN}	0 to V_{DD}	0 to V_{DD}	V
Input Voltage-"L"	V_{IL}	0.8 Max.	0.3 Max.	V
Input Voltage-"H"	V_{IH}	2.2 Min.	2.2 Min.	V
Disable Time	-	150 Max.		nS
Enable Time	-	5 Max.		mS
Start-up Time	ST	10 Max.		mS

Note: All electrical characteristics are defined at the maximum load and operating temperature range.
Please contact us for inquiries about operating temperature range, available frequencies and other conditions.

Dimensions

(Unit : mm)

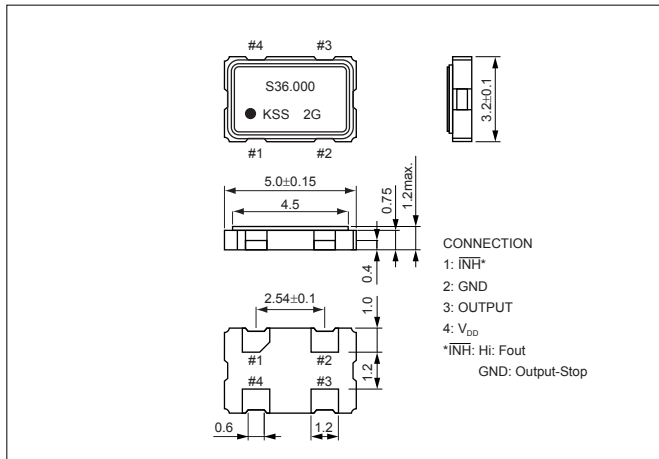

Recommended Land Pattern

(Unit : mm)

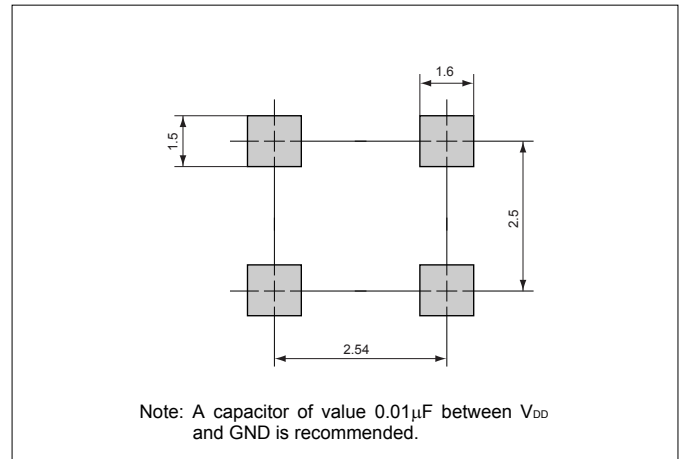

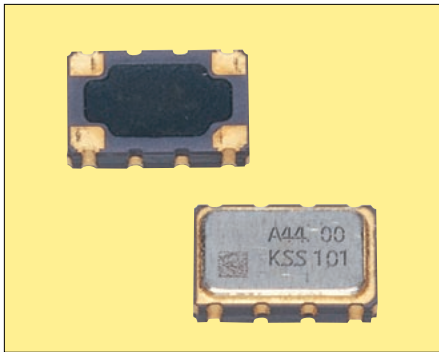

Pb Free

RoHS Compliant

Features

- "H" type leadless ceramic package (Reflow soldering compatible)
- With tri-state function (High Z)
- ±15×10⁻⁶/-40 to +85°C available

Applications

- High Stability Clock Oscillation Wireless LAN (Standard Frequency 44, 40, 22, 20MHz)

How to Order

KC5032H 40.0000 C 3 L D 00
 ① ② ③ ④ ⑤ ⑥ ⑦

- ① Type
- ② Output Frequency
- ③ Output Type (CMOS)
- ④ Supply Voltage (2.7 to 5.5V)
- ⑤ Frequency Tolerance (TC=±15×10⁻⁶)
- ⑥ Symmetry/Enable Function (45/55%, INH)
- ⑦ Customer Special Model Suffix (STD Specification is "00")

Specifications

Items	Symbol	Conditions	Specifications		Units
			Min.	Max.	
Output Frequency Range	F ₀		1.5	50	MHz
Frequency Tolerance (Overall)	F _{tol}		-15	+15	×10 ⁻⁶
Storage Temperature Range	T _{stg}		-55	+125	°C
Operating Temperature Range	T _{use}		-40	+85	°C
Max. Supply Voltage	—		-0.6	6	V
Supply Voltage	V _{DD}		2.7	5.5	V
Current Consumption	I _{DD}	1.5 to 25MHz	—	7	mA
		25 to 55MHz	—	10	
Stand-by Current	I _{std}		—	50	µA
Symmetry	SYM	@50% V _{DD}	45	55	%
Rise / Fall Time	Tr/Tf		—	6	nS
Output Voltage-"L"	V _{OL}		—	10% V _{DD}	V
Output Voltage-"H"	V _{OH}		90% V _{DD}	—	V
Output Load	CL		—	15	pF
Input Voltage Range	V _{IN}		0	V _{DD}	V
Input Voltage-"L"	V _{IL}		70% V _{DD}	—	V
Input Voltage-"H"	V _{IH}		—	30% V _{DD}	V
Start-up Time	ST	1.5 to 25MHz	—	1.5	mS
		25 to 55MHz	—	1	

Note: All electrical characteristics are defined at the maximum load and operating temperature range. Please contact us for inquires about operating temperature range, available frequencies and other conditions.

Dimensions

(Unit : mm)

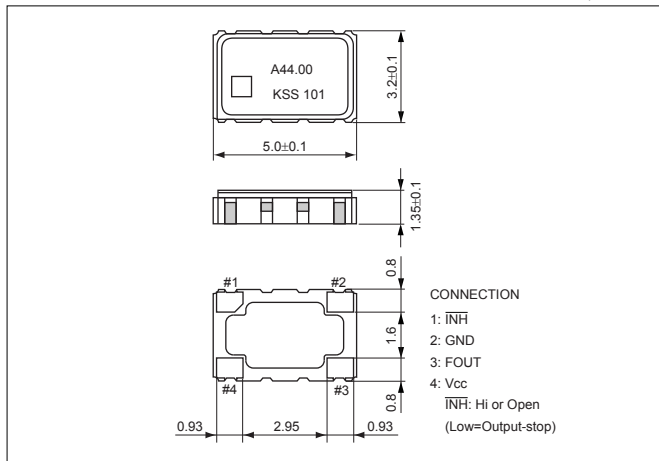

Recommended Land Pattern

(Unit : mm)

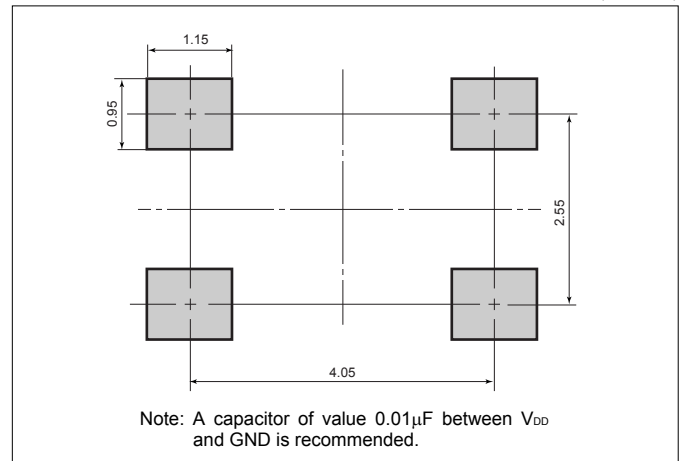



Pb Free

RoHS Compliant

Features

- Miniature ceramic package
- Highly reliable with seam welding
- CMOS output
- Supply voltage $V_{DD} = 1.8V$
Lower voltage available
- $\pm 25 \times 10^{-6}$, $\pm 20 \times 10^{-6}$ available

Table 1

Stability Code	Stability $\times 10^{-6}$	Operating Temperature Range (°C)	Note
0	± 50	-10 to +70	Standard specifications
S	± 30		
U	± 25		
W	± 20	-40 to +85	With only certain frequencies
F	± 100		
G	± 50		

How to Order

KC7050A 25.0000 C 1 0 E 00
 ① ② ③ ④ ⑤ ⑥ ⑦

- ① Type (7.0×5.0mm SMD)
- ② Output Frequency
- ③ Output Type (CMOS)
- ④ Supply Voltage (1.8V)
- ⑤ Frequency Tolerance (See Table 1)
- ⑥ Symmetry/Enable Function (45/55%, Stand-by)
- ⑦ Customer Special Model Suffix (STD Specification is "00")

Packaging (Tape & Reel 1000pcs./reel)

Specifications

Item	Symbol	Conditions	Min.	Max.	Units	
Output Frequency Range	Fo		1.8	39.99	MHz	
Frequency Tolerance	F _{tol}	Initial tolerance, Operating temperature range, Rated power supply voltage change, Load change, Aging (1year @25°C), Shock and vibration	Op. Temp.: -40 to +85°C	-100	+100	$\times 10^{-6}$
			Op. Temp.: -10 to +70°C/ -40 to +85°C	-50	+50	
			Op. Temp.: -10 to +70°C/ -40 to +85°C	-30	+30	
			Op. Temp.: -10 to +70°C	-25	+25	
			Op. Temp.: -10 to +70°C	-20	+20	
Storage Temperature Range	T _{stg}		-55	+125	°C	
Operating Temperature Range	T _{use}	Standard Specifications	-10	+70	°C	
		Extend (Option)	-40	+85		
Max. Supply Voltage	—		-0.5	+3.6	V	
Supply Voltage	V _{DD}	Freq. Tol.Code: 0, S, F	1.71	1.89	V	
		Freq. Tol.Code: U, G, W	1.75	1.85		
Current Consumption (Maximum Loaded)	I _{DD}	1.8≤Fo≤25MHz	—	3	mA	
		25<Fo≤39.99MHz	—	4		
Stand-by Current	I _{std}		—	10	μA	
Symmetry	SYM	@50% V _{DD}	45	55	%	
Rise/ Fall Time (10% V _{DD} to 90% V _{DD} Maximum Loaded)	Tr/Tf		—	9	nS	
Output Voltage-"L"	V _{OL}	I _{OL} =2.8mA	—	10% V _{DD}	V	
Output Voltage-"H"	V _{OH}	I _{OH} =-2.8mA	90% V _{DD}	—	V	
Output Load	L _{CMOS}	CMOS Output	—	15	pF	
Input Voltage Range	V _{IN}		0	V _{DD}	V	
Input Voltage-"L"	V _{IL}		—	30% V _{DD}	V	
Input Voltage-"H"	V _{IH}		70% V _{DD}	—	V	
Disable Time	—		—	150	nS	
Enable Time	—		—	5	mS	
Start-up Time	ST	@ Minimum Operation Voltage to be 0 sec.	—	10	mS	

Note: All electrical characteristics are defined at the maximum load and operating temperature range.
 Please contact us for inquiries about operating temperature range, available frequencies and other conditions.

Dimensions

(Unit : mm)

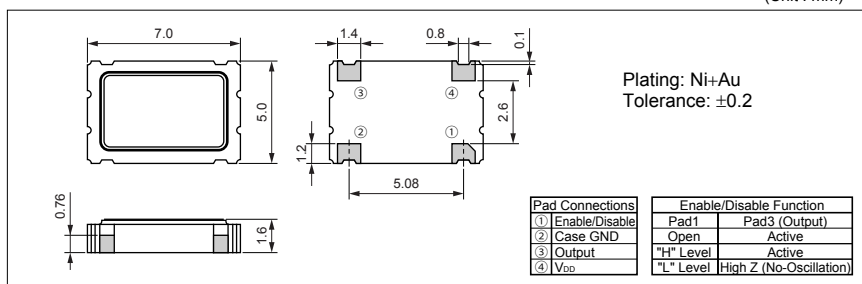

Recommended Land Pattern

(Unit : mm)

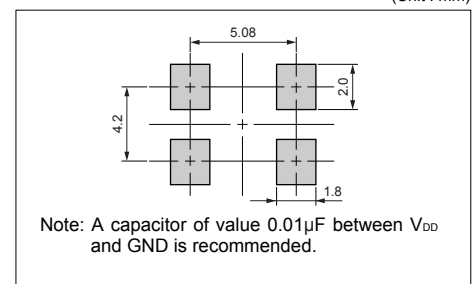



Pb Free

RoHS Compliant

Features

- Miniature ceramic package
- Highly reliable with seam welding
- CMOS output
- Supply voltage $V_{DD} = 2.5V$
Lower voltage available
- $\pm 25 \times 10^{-6}$, $\pm 20 \times 10^{-6}$ available

How to Order

KC7050A 25.0000 C 2 0 E 00
① ② ③ ④ ⑤ ⑥ ⑦

1. Type (7.0×5.0mm SMD)
2. Output Frequency
3. Output Type (CMOS)
4. Supply Voltage (2.5V)
5. Frequency Tolerance (See Table 1)
6. Symmetry/Enable Function (45/55%, Stand-by)
7. Customer Special Model Suffix (STD Specification is "00")

Packaging (Tape & Reel 1000pcs./reel)

Table 1

Stability Code	Stability $\times 10^{-6}$	Operating Temperature Range (°C)	Note
0	± 50	-10 to +70	Standard specifications
S	± 30		
U	± 25		
W	± 20		
F	± 100	-40 to +85	With only certain frequencies
G	± 50		

Specifications

Item	Symbol	Conditions	Min.	Max.	Units	
Output Frequency Range	Fo		1.8	125	MHz	
Frequency Tolerance	F _{tol}	Initial tolerance, Operating temperature range, Rated power supply voltage change, Load change, Aging (1year @25°C), Shock and vibration	Op. Temp.: -40 to +85°C	-100	+100	$\times 10^{-6}$
			Op. Temp.: -10 to +70°C / -40 to +85°C	-50	+50	
			Op. Temp.: -10 to +70°C / -40 to +85°C	-30	+30	
			Op. Temp.: -10 to +70°C	-25	+25	
			Op. Temp.: -10 to +70°C	-20	+20	
Storage Temperature Range	T _{stg}		-55	+125	°C	
Operating Temperature Range	T _{use}	Standard Specifications	-10	+70	°C	
		Extend (Option)	-40	+85		
Max. Supply Voltage	—		-0.5	+7	V	
Supply Voltage	V _{DD}	Freq. Tol.Code: 0, S, F	2.25	2.75	V	
		Freq. Tol.Code: U, G	2.38	2.62		
		Freq. Tol.Code: W	2.43	2.57		
Current Consumption (Maximum Loaded)	I _{DD}	1.8 < Fo <= 20MHz	—	5	mA	
		20 < Fo <= 40MHz	—	10		
		40 < Fo <= 60MHz	—	15		
		60 < Fo <= 85MHz	—	20		
		85 < Fo <= 100MHz	—	22		
		100 < Fo <= 125MHz	—	27		
Stand-by Current	I _{std}		—	10	μA	
Symmetry	SYM	@50% V _{DD}	45	55	%	
Rise/ Fall Time (10% V _{DD} to 90% V _{DD} Maximum Loaded)	Tr/Tf	1.8 < Fo <= 40MHz	—	7	nS	
		40 < Fo <= 85MHz	—	4		
		85 < Fo <= 125MHz	—	3		
Output Volatage-"L"	V _{OL}	I _{OL} =4mA/ 8mA (40<Fo)	—	10% V _{DD}	V	
Output Volatage-"H"	V _{OH}	I _{OH} = -4mA/ -8mA (40<Fo)	90% V _{DD}	—	V	
Output Load	L _{CMOS}	CMOS	—	15	pF	
Input Volatage Range	V _{IN}		0	V _{DD}	V	
Input Volatage-"L"	V _{IL}		—	30% V _{DD}	V	
Input Volatage-"H"	V _{IH}		70% V _{DD}	—	V	
Disable Time	—		—	150	nS	
Enable Time	—		—	5	mS	
Start-up Time	ST	@ Minimum Operation Voltage to be 0 sec.	—	10	mS	

Note: All electrical characteristics are defined at the maximum load and operating temperature range.
Please contact us for inquiries about operating temperature range, available frequencies and other conditions.

Dimensions

(Unit : mm)

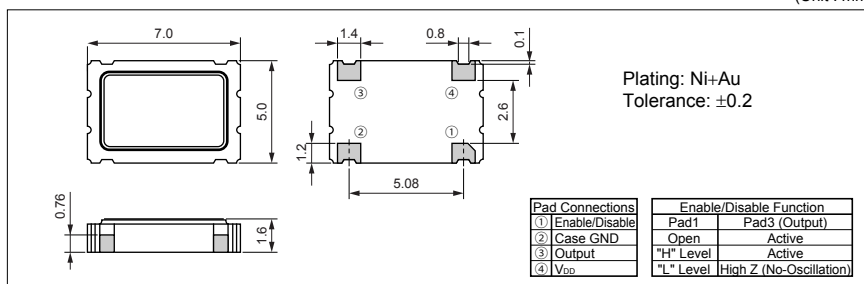

Recommended Land Pattern

(Unit : mm)

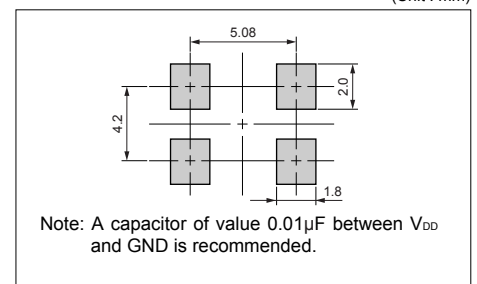



Pb Free

RoHS Compliant

Features

- Miniature ceramic package
- Highly reliable with seam welding
- CMOS output
- Supply voltage $V_{DD}=3.3V$
- $\pm 25 \times 10^{-6}$, $\pm 20 \times 10^{-6}$ available

Table 1

Stability Code	Stability $\times 10^{-6}$	Operating Temperature Range (°C)	Note
0	± 50	-10 to +70	Standard specifications
S	± 30		
U	± 25		
W	± 20		
F	± 100	-40 to +85	With only certain frequencies
G	± 50		

How to Order

KC7050A 25.0000 C 3 0 E 00
 ① ② ③ ④ ⑤ ⑥ ⑦

- ① Type (7.0×5.0mm SMD)
- ② Output Frequency
- ③ Output Type (CMOS)
- ④ Supply Voltage (3.3V)
- ⑤ Frequency Tolerance (See Table 1)
- ⑥ Symmetry/Enable Function (45/55%, Stand-by)
- ⑦ Customer Special Model Suffix (STD Specification is "00")

Packaging (Tape & Reel 1000pcs./reel)

Specifications

Item	Symbol	Conditions	Min.	Max.	Units	
Output Frequency Range	Fo		1.8	160	MHz	
Frequency Tolerance	F _{tol}	Initial tolerance, Operating temperature range, Rated power supply voltage change, Load change, Aging (1year @25°C), Shock and vibration	Op. Temp.: -40 to +85°C	-100	+100	$\times 10^{-6}$
			Op. Temp.: -10 to +70°C / -40 to +85°C	-50	+50	
			Op. Temp.: -10 to +70°C / -40 to +85°C	-30	+30	
			Op. Temp.: -10 to +70°C	-25	+25	
			Op. Temp.: -10 to +70°C	-20	+20	
Storage Temperature Range	T _{stg}		-55	+125	°C	
Operating Temperature Range	T _{use}	Standard Specifications	-10	+70	°C	
		Extend (Option)	-40	+85		
Max. Supply Voltage	—		-0.5	+7	V	
Supply Voltage	V _{DD}	Freq. Tol.Code: 0, S, F	2.97	3.63	V	
		Freq. Tol.Code: U, G	3.14	3.46		
		Freq. Tol.Code: W	3.20	3.40		
Current Consumption (Maximum Loaded)	I _{DD}	1.8≤Fo≤20MHz	—	10	mA	
		20<Fo≤40MHz	—	15		
		40<Fo≤60MHz	—	30		
		60<Fo≤100MHz	—	35		
		100<Fo≤135MHz	—	45		
		135<Fo≤160MHz	—	60		
Stand-by Current	I _{std}		—	10	μA	
Symmetry	SYM	@50% V _{DD}	45	55	%	
Rise/Fall Time (10% V _{DD} to 90% V _{DD} Maximum Loaded)	Tr/Tf	1.8≤Fo≤26MHz	—	10	nS	
		26<Fo≤45MHz	—	8		
		45<Fo≤100MHz	—	5		
		100<Fo≤160MHz	—	2.5		
Output Voltage-"L"	V _{OL}	I _{OL} =8mA	—	10% V _{DD}	V	
Output Voltage-"H"	V _{OH}	I _{OH} =-8mA	90% V _{DD}	—	V	
Output Load	L _{CMOS}	CMOS Output	—	15	pF	
Input Voltage Range	V _{IN}		0	V _{DD}	V	
Input Voltage-"L"	V _{IL}		—	30% V _{DD}	V	
Input Voltage-"H"	V _{IH}		70% V _{DD}	—	V	
Disable Time	—		—	150	nS	
Enable Time	—		—	5	mS	
Start-up Time	ST	@ Minimum Operation Voltage to be 0 sec.	—	10	mS	

Note: All electrical characteristics are defined at the maximum load and operating temperature range. Please contact us for inquiries about operating temperature range, available frequencies and other conditions.

Dimensions

(Unit : mm)

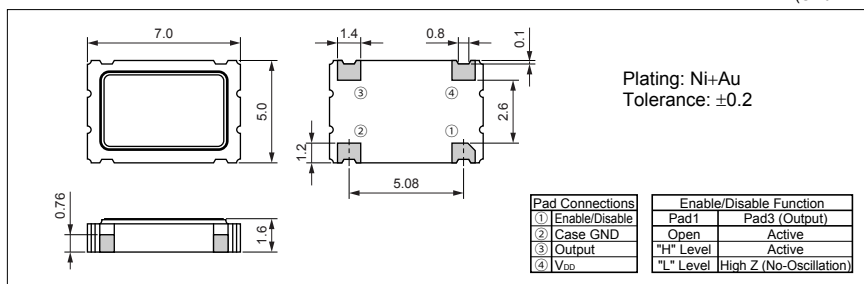

Recommended Land Pattern

(Unit : mm)

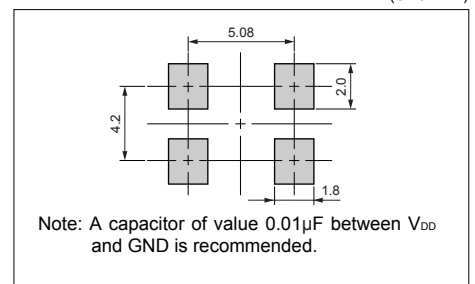



Pb Free

RoHS Compliant

Features

- Miniature ceramic package
- Highly reliable with seam welding
- CMOS output
- Supply voltage $V_{DD}=5.0V$

Table 1

Stability Code	Stability $\times 10^{-6}$	Operating Temperature Range (°C)	Note
0	± 50	-10 to +70	Standard specifications
S	± 30		
U	± 25		
F	± 100	-40 to +85	With only certain frequencies
G	± 50		

How to Order

KC7050A 25.0000 C 5 0 D 00
 ① ② ③ ④ ⑤ ⑥ ⑦

- ① Type (7.0×5.0mm SMD)
- ② Output Frequency
- ③ Output Type (CMOS)
- ④ Supply Voltage (5.0V)
- ⑤ Frequency Tolerance (See Table 1)
- ⑥ Symmetry/Enable Function (45/55%, Disable)
- ⑦ Customer Special Model Suffix (STD Specification is "00")

Packaging (Tape & Reel 1000pcs./reel)

Specifications

Item	Symbol	Conditions	Min.	Max.	Units	
Output Frequency Range	Fo		1.8	50	MHz	
Frequency Tolerance	F _{tol}	Initial tolerance, Operating temperature range, Rated power supply voltage change, Load change, Aging (1year @25°C), Shock and vibration	Op. Temp.: -40 to +85°C	-100	+100	$\times 10^{-6}$
			Op. Temp.: -10 to +70°C / -40 to +85°C	-50	+50	
			Op. Temp.: -10 to +70°C / -40 to +85°C	-30	+30	
			Op. Temp.: -10 to +70°C	-25	+25	
Storage Temperature Range	T _{stg}		-55	+125	°C	
Operating Temperature Range	T _{use}	Standard Specifications	-10	+70	°C	
		Extend (Option)	-40	+85		
Max. Supply Voltage	—		-0.5	+7	V	
Supply Voltage	V _{DD}	Freq. Tol.Code: 0, S, F	4.5	5.5	V	
		Freq. Tol.Code: U, G	4.75	5.25		
Current Consumption (Maximum Loaded)	I _{DD}	1.8≤Fo≤20MHz	—	25	mA	
		20<Fo≤40MHz	—	35		
		40<Fo≤50MHz	—	50		
Disable Current	I _{dis}		—	30	mA	
Symmetry	SYM	@50% V _{DD}	45	55	%	
Rise/ Fall Time (10% V _{DD} to 90% V _{DD} Maximum Loaded)	Tr/Tf	1.8≤Fo≤26MHz	—	10	nS	
		26<Fo≤50MHz	—	8		
Output Voltage-"L"	V _{OL}	I _{OL} =16mA	—	10% V _{DD}	V	
Output Voltage-"H"	V _{OH}	I _{OH} =-16mA	90% V _{DD}	—	V	
Output Load	L _{CMOS}	CMOS Output	—	50	pF	
Input Voltage Range	V _{IN}		0	V _{DD}	V	
Input Voltage-"L"	V _{IL}		—	0.8	V	
Input Voltage-"H"	V _{IH}		2.2	—	V	
Disable Time	—		—	100	nS	
Enable Time	—		—	100	nS	
Start-up Time	ST	@ Minimum Operation Voltage to be 0 sec.	—	10	mS	

Note: All electrical characteristics are defined at the maximum load and operating temperature range.
 Please contact us for inquiries about operating temperature range, available frequencies and other conditions.

Dimensions

(Unit : mm)

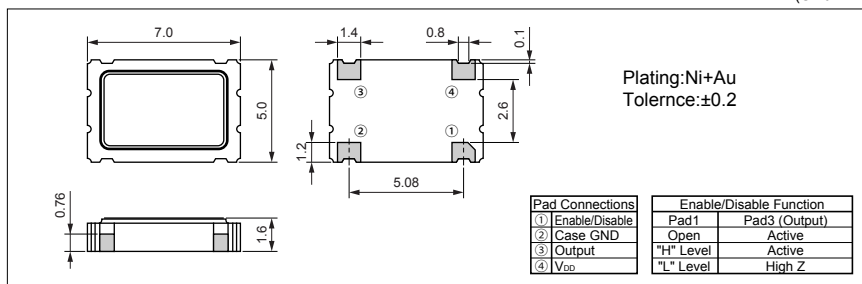

Recommended Land Pattern

(Unit : mm)

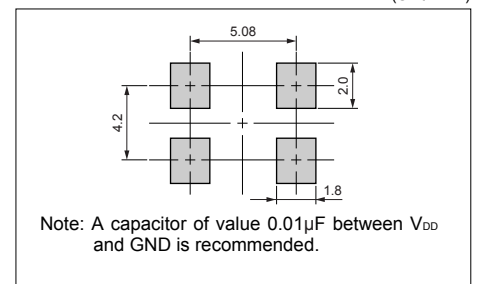

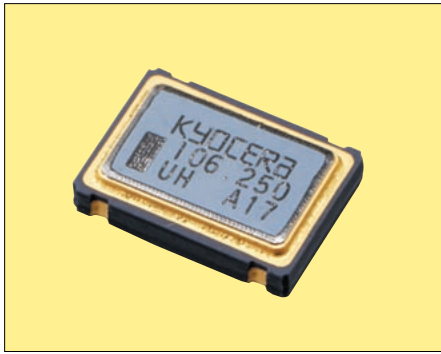

Pb Free

RoHS Compliant

Features

- Miniature ceramic package
- Highly reliable with seam welding
- CMOS output
- Supply voltage $V_{DD}=3.3V$
- With built-in by-pass capacitor

Table 1

Freq. Tol. Code	Tol. $\times 10^{-6}$	Operating Temperature Range (°C)	Note
0	± 50	-10 to +70	Standard specifications
S	± 30		
U	± 25		
F	± 100	-40 to +85	With only certain frequencies
G	± 50		

How to Order

KC7050H 125.000 C 3 0 E 00
 ① ② ③ ④ ⑤ ⑥ ⑦

- ① Type (7.0x5.0mm SMD)
- ② Output Frequency
- ③ Output Type (CMOS)
- ④ Supply Voltage (3.3V)
- ⑤ Frequency Tolerance (See Table 1)
- ⑥ Symmetry/Enable Function (45/55%, Stand-by)
- ⑦ Customer Special Model Suffix (STD Specification is "00")

Packaging (Tape & Reel 1000pcs./reel)

Specifications

Item	Symbol	Conditions	Min.	Max.	Units	
Output Frequency Range	Fo		80	170	MHz	
Frequency Tolerance	F _{tol}	Initial tolerance, Operating temperature range, Rated power supply voltage change, Load change, Aging (1year @25°C), Shock and vibration	Op. Temp.: -40 to +85°C	-100	+100	$\times 10^{-6}$
			Op. Temp.: -10 to +70°C/ -40 to +85°C	-50	+50	
			Op. Temp.: -10 to +70°C/ -40 to +85°C	-30	+30	
			Op. Temp.: -10 to +70°C	-25	+25	
Storage Temperature Range	T _{stg}		-55	+125	°C	
Operating Temperature Range	T _{use}	Standard Specifications	-10	+70	°C	
		Extend (Option)	-40	+85		
Max. Supply Voltage	—		-0.5	+7	V	
Supply Voltage	V _{DD}	Freq. Tol.Code: 0, S, F	2.97	3.63	V	
		Freq. Tol.Code: U, G	3.14	3.46		
Current Consumption (Maximum Loaded)	I _{DD}	80≤Fo≤100MHz	—	40	mA	
		100<Fo≤135MHz	—	50		
		135<Fo≤170MHz	—	60		
Stand-by Current	I _{std}	80≤Fo≤125MHz	—	10	μA	
		125<Fo≤170MHz	—	150		
Symmetry	SYM	@50% V _{DD}	45	55	%	
Rise/ Fall Time (10% V _{DD} to 90% V _{DD} Maximum Loaded)	Tr/Tf	80≤Fo<100MHz	20% V _{DD} to 80% V _{DD} Maximum Loaded	—	3.5	nS
			10% V _{DD} to 90% V _{DD} Maximum Loaded	—	5	
		100≤Fo≤170MHz	20% V _{DD} to 80% V _{DD} Maximum Loaded	—	1.5	
			10% V _{DD} to 90% V _{DD} Maximum Loaded	—	2	
Output Voltage-"L"	V _{OL}	I _{OL} =8mA	—	10% V _{DD}	V	
Output Voltage-"H"	V _{OH}	I _{OH} =-8mA	90% V _{DD}	—	V	
Output Load	L _{CMOS}	CMOS Output	—	15	pF	
Input Voltage Range	V _{IN}		0	V _{DD}	V	
Input Voltage-"L"	V _{IL}		—	30% V _{DD}	V	
Input Voltage-"H"	V _{IH}		70% V _{DD}	—	V	
Disable Time	—		—	150	nS	
Enable Time	—		—	5	mS	
Start-up Time	ST	@ Minimum Operation Voltage to be 0 sec.	—	10	mS	
Deterministic Jitter (DJ)	DJ	Measured with Wavecrest DTS-2079 VIS/6.3.1	—	2	pS	
1Sigma Jitter	1sigma		—	4	pS	

Note: All electrical characteristics are defined at the maximum load and operating temperature range.
 Please contact us for inquiries about operating temperature range, available frequencies and other conditions.

Dimensions

(Unit : mm)

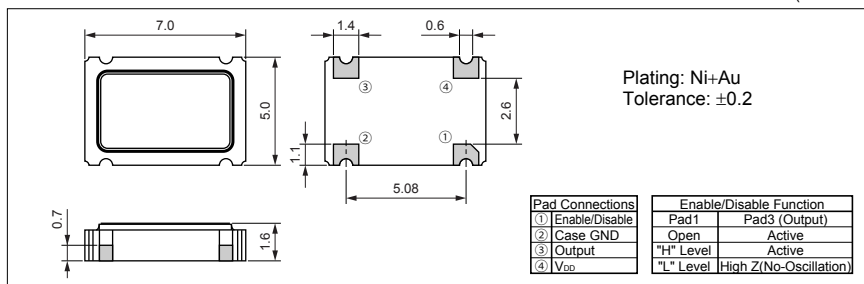

Recommended Land Pattern

(Unit : mm)

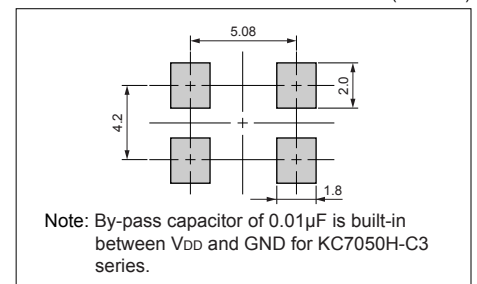

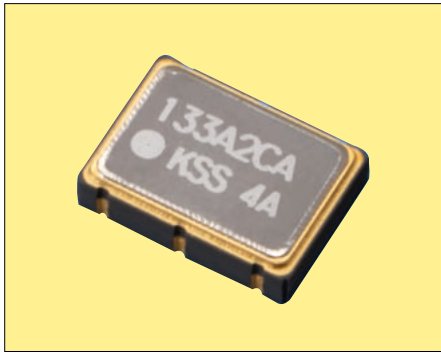

Pb Free

RoHS Compliant

Features

- Low voltage 1.8V
- Low jitter
- LV-CMOS output
- Operation at fundamental high frequency

Table 1

Freq. Code	Tol. $\times 10^{-6}$	Operating Temperature Range (°C)	Note
1	± 100	0 to +70	Standard specifications

How to Order

KC7050S 155.520 C 1 1 B 00
 ① ② ③ ④ ⑤ ⑥ ⑦

- ① Type (7.0×5.0mm SMD)
- ② Output Frequency
- ③ Output Type (CMOS)
- ④ Supply Voltage (1.8V)
- ⑤ Frequency Tolerance (See Table 1)
- ⑥ Symmetry/Enable Function (40/60%, Stand-by)
- ⑦ Customer Special Model Suffix (STD Specification is "00")

Packaging (Tape & Reel 1000pcs./reel)

Specifications

Item	Symbol	Conditions	Min.	Max.	Units
Output Frequency Range	Fo		100	170	MHz
Frequency Tolerance	F _{tol}	Initial tolerance, Operating temperature range, Rated power supply voltage change, Load change, Aging (1year @25°C), Shock and vibration	-100	+100	$\times 10^{-6}$
Storage Temperature Range	T _{stg}		-55	+125	°C
Operating Temperature Range	T _{use}	Standard Specifications	0	+70	°C
Max. Supply Voltage	—		-0.5	+5	V
Supply Voltage	V _{DD}		1.62	1.98	V
Current Consumption (Standard Loaded)	I _{DD}		—	50	mA
Symmetry	SYM		40	60	%
Rise/ Fall Time (10% V _{DD} to 90% V _{DD} Standard Loaded)	Tr/Tf		—	2	nS
Output Voltage-"L"	V _{OL}		—	10% V _{DD}	V
Output Voltage-"H"	V _{OH}		90% V _{DD}	—	V
Output Load (CMOS)	L _{CMOS}		—	15	pF
Input Voltage Range	V _{IN}		0	V _{DD}	V
Input Voltage-"L"	V _{IL}		—	30% V _{DD}	V
Input Voltage-"H"	V _{IH}		70% V _{DD}	—	V
Disable Time	—		—	200	nS
Enable Time	—		—	2	mS
Start-up Time	ST	@ Minimum Operation Voltage to be 0 sec.	—	10	mS
Deterministic Jitter (DJ)	DJ	Measured with Wavecrest DTS-2079 VIS / 6.3.1	0.2 typ.		ps
1 Sigma Jitter	1 Sigma		3 typ.		ps
Peak to Peak Jitter	Pk-Pk		20 typ.		ps

Note: All electrical characteristics are defined at the maximum load and operating temperature range. Please contact us for inquiries about operating temperature range, available frequencies and other conditions.

Dimensions

(Unit : mm)

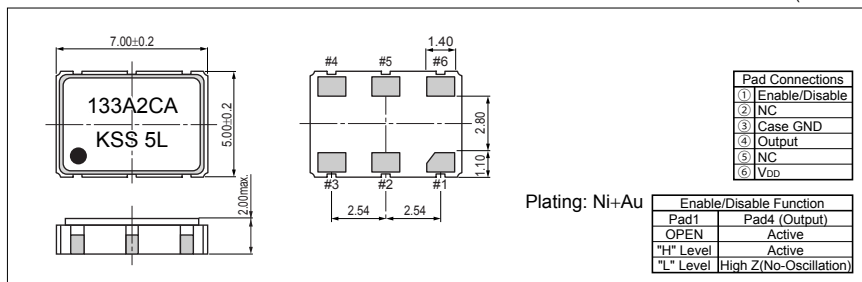

Recommended Land Pattern

(Unit : mm)

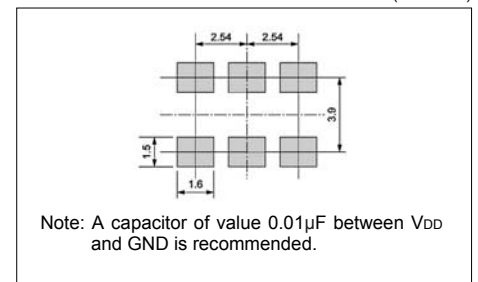



Pb Free

RoHS Compliant

Features

- Low voltage 2.5V
- Low jitter
- LV-CMOS output
- Operation at fundamental high frequency

Table 1

Freq. Tol. Code	Tol. ×10 ⁻⁶	Operating Temperature Range (°C)	Note
1	±100	0 to +70	Standard specifications

How to Order

KC7050S 155.520 C 2 1 B 00
 ① ② ③ ④ ⑤ ⑥ ⑦

- ① Type (7.0×5.0mm SMD)
- ② Output Frequency
- ③ Output Type (CMOS)
- ④ Supply Voltage (2.5V)
- ⑤ Frequency Tolerance (See Table 1)
- ⑥ Symmetry/Enable Function (40/60%, Stand-by)
- ⑦ Customer Special Model Suffix (STD Specification is "00")

Packaging (Tape & Reel 1000pcs./reel)

Specifications

Item	Symbol	Conditions	Min.	Max.	Units
Output Frequency Range	F _o		100	200	MHz
Frequency Tolerance	F _{tol}	Initial tolerance, Operating temperature range, Rated power supply voltage change, Load change, Aging (1year @25°C), Shock and vibration	-100	+100	×10 ⁻⁶
Storage Temperature Range	T _{stg}		-55	+125	°C
Operating Temperature Range	T _{use}	Standard Specifications	-10	+70	°C
Max. Supply Voltage	—		-0.5	+5	V
Supply Voltage	V _{DD}		2.38	2.62	V
Current Consumption (Standard Loaded)	I _{DD}		—	50	mA
Symmetry	SYM		40	60	%
Rise/ Fall Time (10% V _{DD} to 90% V _{DD} Standard Loaded)	Tr/Tf		—	2	nS
Output Voltage-"L"	V _{OL}		—	10% V _{DD}	V
Output Voltage-"H"	V _{OH}		90% V _{DD}	—	V
Output Load (CMOS)	L _{CMOS}		—	15	pF
Input Voltage Range	V _{IN}		0	V _{DD}	V
Input Voltage-"L"	V _{IL}		—	30% V _{DD}	V
Input Voltage-"H"	V _{IH}		70% V _{DD}	—	V
Disable Time	—		—	200	nS
Enable Time	—		—	2	mS
Start-up Time	ST	@ Minimum Operation Voltage to be 0 sec.	—	10	mS
Deterministic Jitter (DJ)	DJ	Measured with Wavecrest DTS-2079 VIS / 6.3.1	0.2 typ.		ps
1 Sigma Jitter	1 Sigma		3 typ.		ps
Peak to Peak Jitter	Pk-Pk		20 typ.		ps

Note: All electrical characteristics are defined at the maximum load and operating temperature range. Please contact us for inquiries about operating temperature range, available frequencies and other conditions.

Dimensions

(Unit : mm)

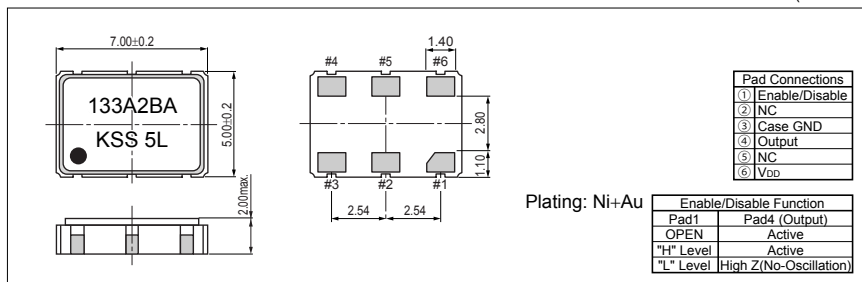

Recommended Land Pattern

(Unit : mm)

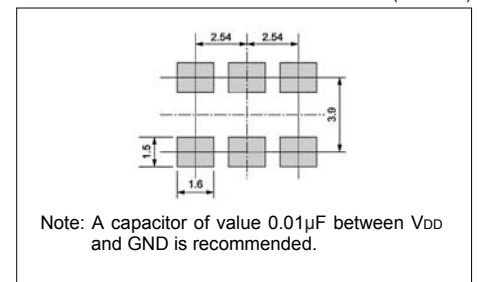

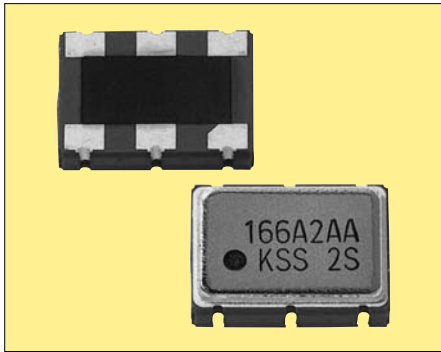

Pb Free

RoHS Compliant

Features

- CMOS output 3.3V
- Low jitter
- Operation at fundamental high frequency

How to Order

KC7050S 155.520 C 3 1 B 00
 ① ② ③ ④ ⑤ ⑥ ⑦

- ① Type (7.0×5.0mm SMD)
- ② Output Frequency
- ③ Output Type (CMOS)
- ④ Supply Voltage (3.3V)
- ⑤ Frequency Tolerance (See Table 1)
- ⑥ Symmetry/Enable Function (40/60%, Stand-by)
- ⑦ Customer Special Model Suffix (STD Specification is "00")

Packaging (Tape & Reel 1000pcs./reel)

Table 1

Freq. Code	Tol. ×10 ⁻⁶	Operating Temperature Range (°C)	Note
1	±100	0 to +70	Standard specifications

Specifications

Item	Symbol	Conditions	Min.	Max.	Units
Output Frequency Range	F _o		100	200	MHz
Frequency Tolerance	F _{tol}	Initial tolerance, Operating temperature range, Rated power supply voltage change, Load change, Aging (1year @25°C), Shock and vibration	-100	+100	×10 ⁻⁶
Storage Temperature Range	T _{stg}		-55	+125	°C
Operating Temperature Range	T _{use}	Standard Specifications	0	+70	°C
Max. Supply Voltage	—		-0.5	+5	V
Supply Voltage	V _{DD}		3.14	3.46	V
Current Consumption (Standard Loaded)	I _{DD}		—	60	mA
Symmetry	SYM		40	60	%
Rise/ Fall Time (10% V _{DD} to 90% V _{DD} Standard Loaded)	Tr/Tf		—	2	nS
Output Voltage-"L"	V _{OL}		—	10% V _{DD}	V
Output Voltage-"H"	V _{OH}		90% V _{DD}	—	V
Output Load (CMOS)	L _{CMOS}		—	15	pF
Input Voltage Range	V _{IN}		0	V _{DD}	V
Input Voltage-"L"	V _{IL}		—	30% V _{DD}	V
Input Voltage-"H"	V _{IH}		70% V _{DD}	—	V
Disable Time	—		—	200	nS
Enable Time	—		—	2	mS
Start-up Time	ST	@ Minimum Operation Voltage to be 0 sec.	—	10	mS
Deterministic Jitter (DJ)	DJ	Measured with Wavecrest DTS-2079 VIS / 6.3.1	0.2 typ.		ps
1 Sigma Jitter	1 Sigma		3 typ.		ps
Peak to Peak Jitter	Pk-Pk		20 typ.		ps

Note: All electrical characteristics are defined at the maximum load and operating temperature range. Please contact us for inquiries about operating temperature range, available frequencies and other conditions.

Dimensions

(Unit : mm)

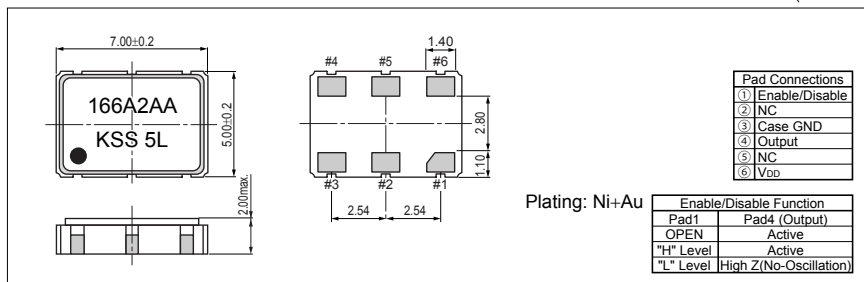

Recommended Land Pattern

(Unit : mm)

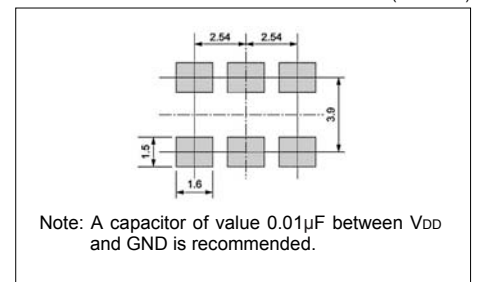

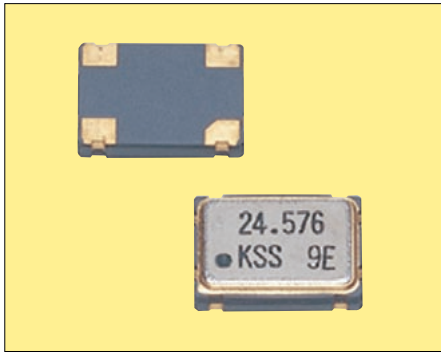

Pb Free

RoHS Compliant

Features

- Surface mount type suitable for auto pick-and-place
- Reflow soldering compatible
- CMOS, TTL IC direct drive is possible
- With tri-state function
- Broad frequency range from 1.8MHz to 50MHz
- Supply voltage $V_{DD}=3.3/5.0V$ available

Frequency Tolerance (Overall)

Freq.Tol. Code	$\times 10^{-6}$	Operating Temperature Range(°C)	Notes
1	± 100	-10 to +70	1.8 to 50MHz
0	± 50	(standard)	
S	± 30		

How to Order

KC7050B 25.0000 C 3 0 A 00
 ① ② ③ ④ ⑤ ⑥ ⑦

- ① Type
- ② Output Frequency
- ③ Output Type (CMOS)
- ④ Supply Voltage 5=5.0V, 3=3.3V
- ⑤ Frequency Tolerance (See Table at Left)
- ⑥ Symmetry/Enable Function (40/60%, INH)
- ⑦ Customer Special Model Suffix (STD Specification is "00")

Specifications

Items	Symbol	Specifications		Units
		KC7050Bxx.xxxxC5xA00 (FXO-31FH)	KC7050Bxx.xxxxC3xA00 (FXO-31FL)	
Output Frequency Range	F_0	1.8 to 50		MHz
Frequency Tolerance (Overall)	F_{tol}	± 30		$\times 10^{-6}$
		± 50		
		± 100		
Storage Temperature, Range	T_{stg}	-40 to +85		°C
Operating Temperature, Range	T_{use}	-10 to +70		°C
Max. Supply Voltage	—	7 Max.		V
Supply Voltage	V_{DD}	5 \pm 0.5	3.3 \pm 0.3	V
Current Consumption	I_{DD}	25 Max. (1.8 to 15MHz)	18 Max. (1.8 to 39.9MHz)	mA
		30 Max. (15.1 to 32MHz)		
		45 Max. (32.1 to 50MHz)	25 Max. (40 to 50MHz)	
Stand-by Current	I_{std}	10 Max.		μ A
Symmetry	SYM	40 to 60@50% V_{DD}		%
Rise / Fall Time	T_r/T_f	10 Max.		nS
Output Voltage-"L"	V_{OL}	10% V_{DD} Max.		V
Output Voltage-"H"	V_{OH}	90% V_{DD} Min.		V
Output Load	CL	50 Max.	20 Max.	pF
Input Voltage Range	V_{IN}	0 to V_{DD}	0 to V_{DD}	V
Input Voltage-"L"	V_{IL}	0.8 Max.	0.3 Max.	V
Input Voltage-"H"	V_{IH}	2.2 Min.	2.2 Min.	V
Disable Time	—	150 Max.		nS
Enable Time	—	5 Max.		mS
Start-up Time	ST	10 Max.		mS

Note: All electrical characteristics are defined at the maximum load and operating temperature range.
 Please contact us for inquiries about operating temperature range, available frequencies and other conditions.

Dimensions

(Unit : mm)

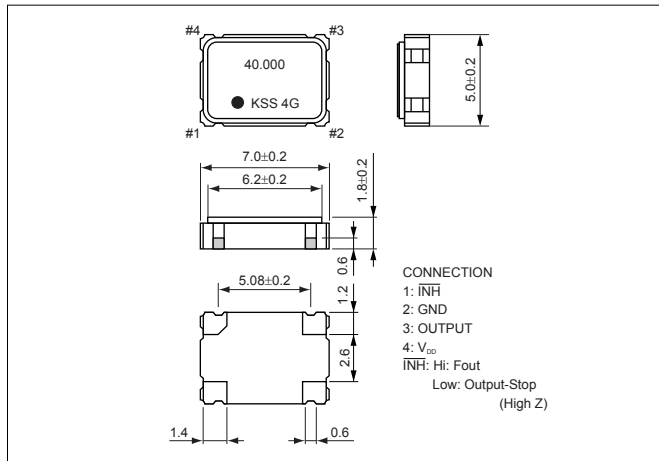

Recommended Land Pattern

(Unit : mm)

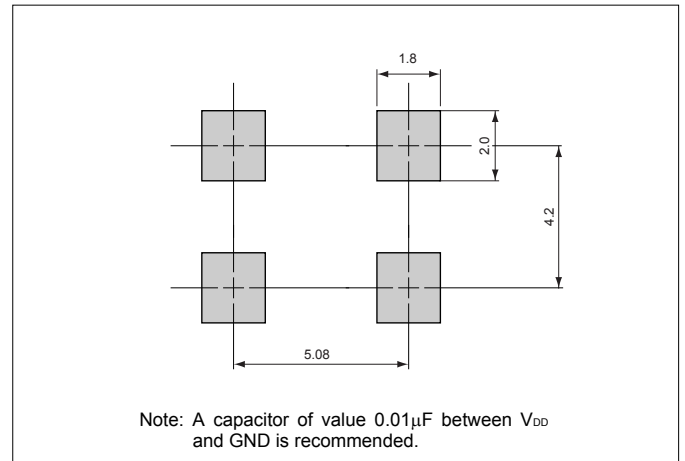

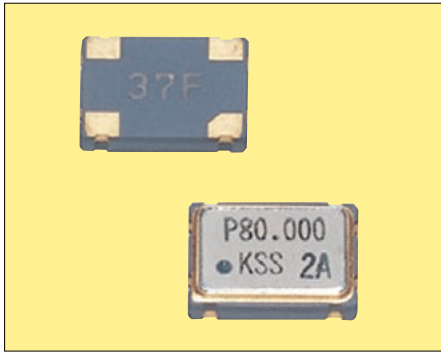

Pb Free

RoHS Compliant

Features

- Surface mount type suitable for auto pick-and-place
- Reflow compatible
- CMOS, TTL IC direct drive is possible
- With tri-state function
- Broad frequency range from 80MHz to 125MHz, (PLL circuit is built in)
- Supply voltage V_{DD} =3.3/5.0V available

Frequency Tolerance (Overall)

Freq.Tol. Code	$\times 10^{-6}$	Operating Temperature Range(°C)	Notes
1	± 100	0 to +70 (standard)	80 to 125MHz
0	± 50		

How to Order

KC7050B 80.0000 C 3 0 A 00
 ① ② ③ ④ ⑤ ⑥ ⑦

- ① Type
- ② Output Frequency
- ③ Output Type (CMOS)
- ④ Supply Voltage 5–5.0V, 3–3.3V
- ⑤ Frequency Tolerance (See Table at Left)
- ⑥ Symmetry/Enable Function (40/60%, INH)
- ⑦ Customer Special Model Suffix (STD Specification is "00")

Specifications

Items	Symbol	Conditions	Specifications		Units
			Min.	Max.	
Output Frequency Range	F_0		80	125	MHz
Frequency Tolerance (Overall)	F_{tol}		-50 -100	+50 +100	$\times 10^{-6}$
Storage Temperature, Range	T_{stg}		-20	+80	°C
Operating Temperature, Range	T_{use}		0	+70	°C
Max. Supply Voltage	—		—	6	V
Supply Voltage	V_{DD}	3.3V Type	3.135	3.465	V
		5.5V Type	4.75	5.25	
Current Consumption	I_{DD}		—	70	mA
Stand-by Current	I_{std}		—	60	μ A
Symmetry	SYM	@50% V_{DD}	40	60	%
Rise / Fall Time	T_r/T_f		—	7	nS
Output Voltage-"L"	V_{OL}		—	10% V_{DD}	V
Output Voltage-"H"	V_{OH}	@3.3V	2.8	—	V
		@5.0V	4	—	
Output Load	CL		—	15	pF
Input Voltage Range	V_{IN}		V_{SS}	V_{DD}	V
Input Voltage-"L"	V_{IL}		—	30% V_{DD}	V
Input Voltage-"H"	V_{IH}		70% V_{DD}	—	V
Disable Time	—		—	1	mS
Enable Time	—		—	3	mS
Start-up Time	ST		—	10	mS

Note: All electrical characteristics are defined at the maximum load and operating temperature range.
 Please contact us for inquires about operating temperature range, available frequencies and other conditions.

Dimensions

(Unit : mm)

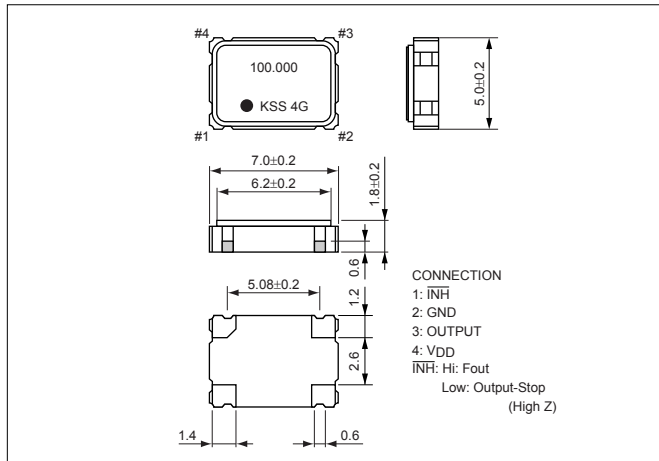

Recommended Land Pattern

(Unit : mm)

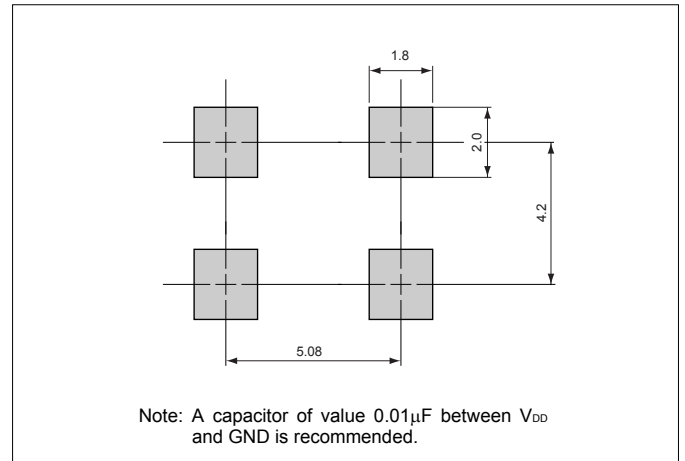

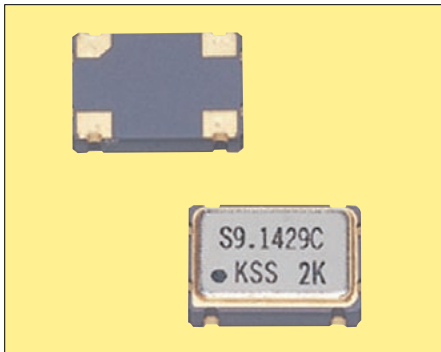

Pb Free

RoHS Compliant

Features

- This crystal oscillator has a built-in high-precision CMOS IC suitable for a wide range of temperature
- Lower noise and lower current for reduced power consumption
- Supply voltage V_{DD} =3.3/5.0V available

Frequency Tolerance (Overall)

Freq.Tol. Code	Freq.Tol. $\times 10^{-6}$	Operating Temperature Range (°C)	Notes
P	± 100	-30 to +85	1.8 to 40MHz
Q	± 50	(Standard)	
R	± 30		

How to Order

KC7050B 25.0000 C 3 Q A 00
 ① ② ③ ④ ⑤ ⑥ ⑦

- ① Type
- ② Output Frequency
- ③ Output Type (CMOS)
- ④ Supply Voltage 5=5.0V, 3=3.3V
- ⑤ Frequency Tolerance (See Table at Left)
- ⑥ Symmetry/Enable Function (40/60%, INH)
- ⑦ Customer Special Model Suffix (STD Specification is "00")

Specifications

Items	Symbol	Specifications		Units
		KC7050Bxx.xxxxC5xA00 (FXO-34F)	KC7050Bxx.xxxxC3xA00 (FXO-34FL)	
Output Frequency Range	F_0	1.8 to 40		MHz
Frequency Tolerance (Overall)	F_{tol}	± 30		$\times 10^{-6}$
		± 50		
		± 100		
Storage Temperature, Range	T_{stg}	-40 to +85		°C
Operating Temperature, Range	T_{use}	-30 to +85		°C
Max. Supply Voltage	-	7 Max.		V
Supply Voltage	V_{DD}	5 \pm 5%	3.3 \pm 5%	V
Current Consumption	I_{DD}	12 Max.	10 Max.	mA
Stand-by Current	I_{std}	8 Max.		μ A
Symmetry	SYM	40 to 60@50% V_{DD}		%
Rise / Fall Time	T_r/T_f	12 Max.	16 Max.	nS
Output Voltage-"L"	V_{OL}	10% V_{DD} Max.		V
Output Voltage-"H"	V_{OH}	90% V_{DD} Min.		V
Output Load	CL	15 Max.		pF
Input Voltage Range	V_{IN}	0 to V_{DD}	0 to V_{DD}	V
Input Voltage-"L"	V_{IL}	0.8 Max.	0.3 Max.	V
Input Voltage-"H"	V_{IH}	2.2 Min.	2.2 Min.	V
Disable Time	-	150 Max.		nS
Enable Time	-	5 Max.		mS
Start-up Time	ST	10 Max.		mS

Note: All electrical characteristics are defined at the maximum load and operating temperature range.
 Please contact us for inquiries about operating temperature range, available frequencies and other conditions.

Dimensions

(Unit : mm)

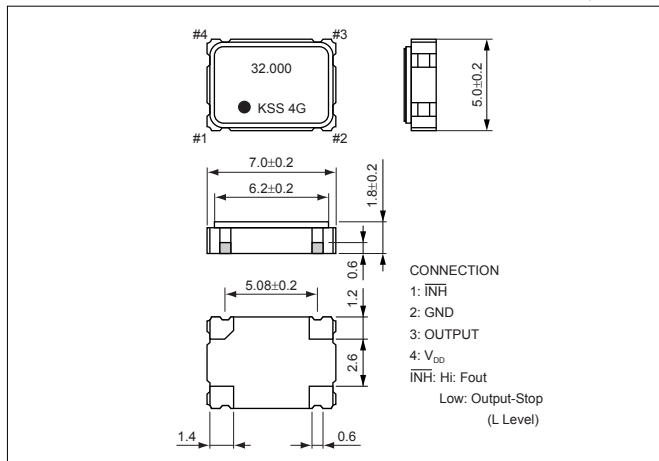

Recommended Land Pattern

(Unit : mm)

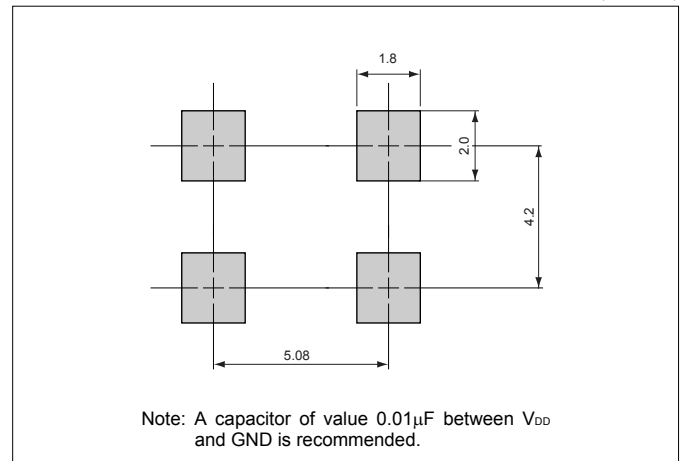

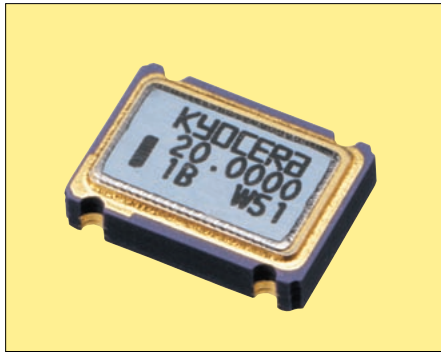

Pb Free

RoHS Compliant

Features

- Miniature ceramic package
- Highly reliable with seam welding
- CMOS output
- Supply voltage $V_{DD}=3.3V$
- $\pm 25 \times 10^{-6}$ available

Table 1

Freq. Tol. Code	Freq. Tol. $\times 10^{-6}$	Operating Temperature Range (°C)	Note
0	± 50	-10 to +70	Standard specifications
S	± 30		
U	± 25	-40 to +85	With only certain frequencies
F	± 100		
G	± 50		

How to Order

KC7050C 25.0000 C 3 0 E 00
 ① ② ③ ④ ⑤ ⑥ ⑦

- ① Type (7.0×5.0mm SMD)
- ② Output Frequency
- ③ Output Type (CMOS)
- ④ Supply Voltage (3.3V)
- ⑤ Frequency Tolerance (See Table 1)
- ⑥ Symmetry/ Enable Function
(E: 45/55%, Stand-by) (D: 45/55%, Disable)
- ⑦ Customer Special Model Suffix
(STD Specification is "00")

Packaging (Tape & Reel 1000pcs./reel)

Specifications

Item	Symbol	Conditions	Min.	Max.	Units	
Output Frequency Range	Fo		1.5	80	MHz	
Frequency Tolerance	F _{tol}	Initial tolerance, Operating temperature range, Rated power supply voltage change, Load change, Aging (1year @25°C), Shock and vibration	Op. Temp.: -40 to +85°C	-100	+100	$\times 10^{-6}$
			Op. Temp.: -10 to +70°C/ -40 to +85°C	-50	+50	
			Op. Temp.: -10 to +70°C/ -40 to +85°C	-30	+30	
			Op. Temp.: -10 to +70°C	-25	+25	
Storage Temperature Range	T _{stg}		-55	+125	°C	
Operating Temperature Range	T _{use}	Standard Specifications	-10	+70	°C	
		Extend (Option)	-40	+85		
Max. Supply Voltage	—		-0.5	+7	V	
Supply Voltage	V _{DD}	Freq. Tol.Code: 0, S, F	2.97	3.63	V	
		Freq. Tol.Code: U, G	3.14	3.46		
Current Consumption (Maximum Loaded)	I _{DD}	1.5≤Fo≤20MHz	—	10	mA	
		20<Fo≤40MHz	—	15		
		40<Fo≤60MHz	—	20		
		60<Fo≤80MHz	—	30		
Stand-by/Disable Current	I _{std} /I _{dis}	1.5≤Fo≤32MHz (Stand-by Function)	—	10	μA	
		32<Fo≤50MHz (Disable Function)	—	15	mA	
		50<Fo≤80MHz (Stand-by Function)	—	10	μA	
Symmetry	SYM	@50% V _{DD}	45	55	%	
Rise/Fall Time (10% V _{DD} to 90% V _{DD} Maximum Loaded)	Tr/Tf	1.5≤Fo≤26MHz	—	10	nS	
		26<Fo≤45MHz	—	8		
		45<Fo≤80MHz	—	5		
Output Voltage-"L"	V _{OL}	I _{OL} =8mA	—	10% V _{DD}	V	
Output Voltage-"H"	V _{OH}	I _{OH} =-8mA	90% V _{DD}	—	V	
Output Load	L _{CMOS}	CMOS Output	—	15	pF	
Input Voltage Range	V _{IN}		0	V _{DD}	V	
Input Voltage-"L"	V _{IL}		—	30% V _{DD}	V	
Input Voltage-"H"	V _{IH}		70% V _{DD}	—	V	
Disable Time	—		—	150	nS	
Enable Time	—	1.5≤Fo≤32MHz (Stand-by Function)	—	5	mS	
		32<Fo≤50MHz (Disable Function)	—	150	nS	
		50<Fo≤80MHz (Stand-by Function)	—	5	mS	
Start-up Time	ST	@ Minimum Operation Voltage to be 0 sec.	—	10	mS	

Note: All electrical characteristics are defined at the maximum load and operating temperature range.
 Please contact us for inquiries about operating temperature range, available frequencies and other conditions.

Dimensions

(Unit : mm)

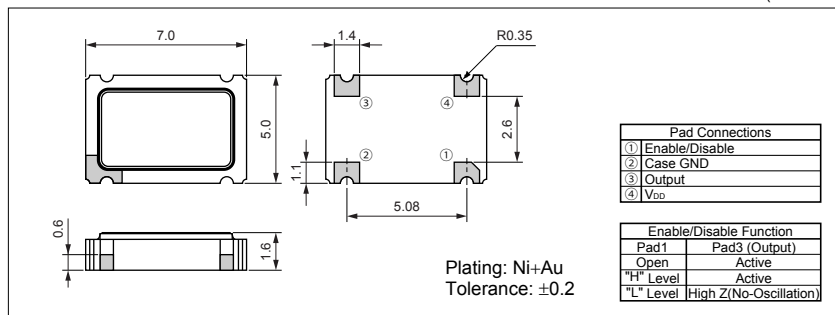

Recommended Land Pattern

(Unit : mm)

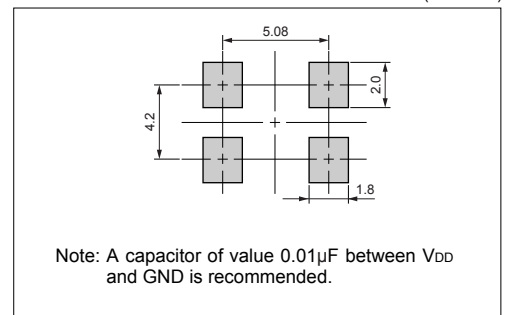

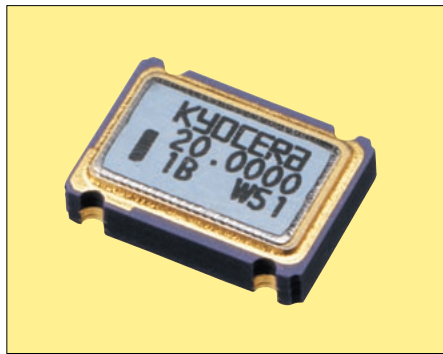

Pb Free

RoHS Compliant

Features

- Miniature ceramic package
- Highly reliable with seam welding
- CMOS output
- Supply voltage $V_{DD}=5.0V$
- $\pm 25 \times 10^{-6}$ available

Table 1

Freq. Tol. Code	Freq. Tol. $\times 10^{-6}$	Operating Temperature Range (°C)	Note
0	± 50	-10 to +70	Standard specifications
S	± 30		
U	± 25		
F	± 100	-40 to +85	With only certain frequencies
G	± 50		

How to Order

KC7050C 25.0000 C 5 0 D 00
 ① ② ③ ④ ⑤ ⑥ ⑦

- ① Type (7.0×5.0mm SMD)
- ② Output Frequency
- ③ Output Type (CMOS)
- ④ Supply Voltage (5.0V)
- ⑤ Frequency Tolerance (See Table 1)
- ⑥ Symmetry/ Enable Function (45/55%, Disable)
- ⑦ Customer Special Model Suffix (STD Specification is "00")

Packaging (Tape & Reel 1000pcs./reel)

Specifications

Item	Symbol	Conditions	Min.	Max.	Units	
Output Frequency Range	Fo		1.5	68	MHz	
Frequency Tolerance	F _{tol}	Initial tolerance, Operating temperature range, Rated power supply voltage change, Load change, Aging (1year @25°C), Shock and vibration	Op. Temp.: -40 to +85°C	-100	+100	$\times 10^{-6}$
			Op. Temp.: -10 to +70°C/ -40 to +85°C	-50	+50	
			Op. Temp.: -10 to +70°C/ -40 to +85°C	-30	+30	
			Op. Temp.: -10 to +70°C	-25	+25	
Storage Temperature Range	T _{stg}		-55	+125	°C	
Operating Temperature Range	T _{use}	Standard Specifications	-10	+70	°C	
		Extend (Option)	-40	+85		
Max. Supply Voltage	—		-0.5	+7	V	
Supply Voltage	V _{DD}	Freq. Tol.Code: 0, S, F	4.5	5.5	V	
		Freq. Tol.Code: U, G	4.75	5.25		
Current Consumption (Maximum Loaded)	I _{DD}	1.5<Fo≤20MHz	—	25	mA	
		20<Fo≤40MHz	—	35		
		40<Fo≤68MHz	—	50		
Disable Current	I _{dis}		—	30	mA	
Symmetry	SYM	@50% V _{DD}	45	55	%	
Rise/Fall Time (10% V _{DD} to 90% V _{DD} Maximum Loaded)	Tr/Tf	1.5<Fo≤26MHz	—	10	nS	
		26<Fo≤50MHz	—	8		
		50<Fo≤68MHz	—	5		
Output Voltage-"L"	V _{OL}	I _{OL} =16mA	—	10% V _{DD}	V	
Output Voltage-"H"	V _{OH}	I _{OH} =-16mA	90% V _{DD}	—	V	
Output Load	L _{CMOS}	CMOS Output	1.5<Fo≤50MHz	—	50	pF
			50<Fo≤68MHz	—	15	
Input Voltage Range	V _{IN}		0	V _{DD}	V	
Input Voltage-"L"	V _{IL}		—	0.8	V	
Input Voltage-"H"	V _{IH}		2.2	—	V	
Disable Time	—		—	100	nS	
Enable Time	—		—	100	mS	
Start-up Time	ST	@ Minimum Operation Voltage to be 0 sec.	—	10	mS	

Note: All electrical characteristics are defined at the maximum load and operating temperature range. Please contact us for inquiries about operating temperature range, available frequencies and other conditions.

Dimensions

(Unit : mm)

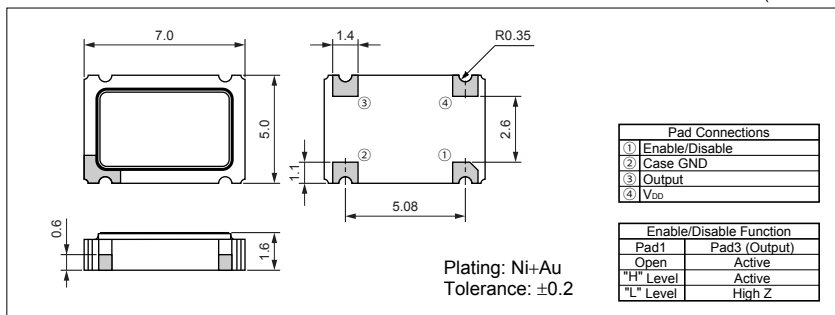

Recommended Land Pattern

(Unit : mm)

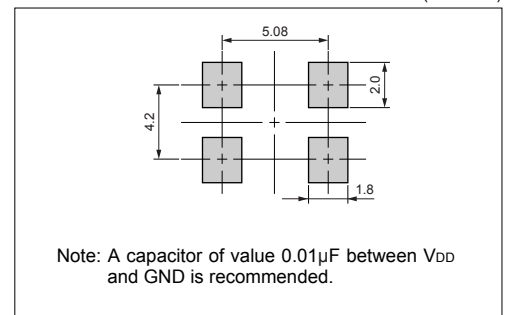

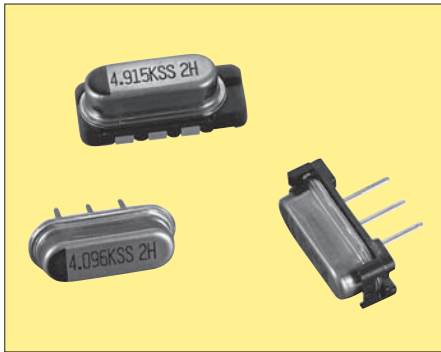

Pb Free

RoHS Compliant

Features

- Compact oscillator with a CMOS IC built in that is the same shape (height 3.5mm) as a crystal device
- It is a hermetic sealed type with a metal case
- The case comes with a grounding terminal
- It is also possible to attach a stand-off (option)
- It is provided with multiple standard frequencies

Applications

- Amusement

How to Order

KCJXOx- 20.000 C 5 1 C 00
 ① ② ③ ④ ⑤ ⑥ ⑦

- ① Type (KCJXO5 or KCJXO7)
- ② Output Frequency
- ③ Output Type (CMOS)
- ④ Supply Voltage (5.0V)
- ⑤ Frequency Tolerance
- ⑥ Symmetry/Enable Function (40/60%)
- ⑦ Customer Special Model Suffix
 "00" for Standard Specifications
 "S0" for Stand-off Type
 "F0" for SMD Type

Specifications

Items	Symbol	Conditions	Specifications		Units
			Min.	Max.	
Output Frequency Range	F ₀	KCJXO5 Type KCJXO7 Type	1 20.1	20 70	MHz
Frequency Tolerance (Overall)	F _{tol}		-100	+100	×10 ⁻⁶
Storage Temperature Range	T _{stg}		-20	+80	°C
Operating Temperature Range	T _{use}		-10	+70	°C
Supply Voltage	V _{DD}		4.5	5.5	V
Current Consumption	I _{DD}	KCJXO5 Type (1 to 20MHz)	-	20	mA
		KCJXO7 Type (20.1 to 50MHz)	-	25	
		KCJXO7 Type (50.1 to 70MHz)	-	50	
Symmetry	SYM	@50% V _{DD}	40	60	%
Rise / Fall Time	Tr/Tf	KCJXO5 Type (1 to 20MHz)	-	20	nS
		KCJXO7 Type (20.1 to 50MHz)	-	15	
		KCJXO7 Type (50.1 to 70MHz)	-	10	
Output Voltage-"L"	V _{OL}		-	10% V _{DD}	V
Output Voltage-"H"	V _{OH}		90% V _{DD}	-	V
Output Load	CL	KCJXO5 Type (1 to 20MHz)	-	50	pF
		KCJXO7 Type (20.1 to 70MHz)	-	15	
Start-up Time	ST	KCJXO5 Type (1 to 20MHz)	-	3	mS
		KCJXO7 Type (20.1 to 70MHz)	-	10	

Note: All electrical characteristics are defined at the maximum load and operating temperature range.
 Please contact us for inquiries about operating temperature range, available frequencies and other conditions.

Dimensions

(Unit : mm)

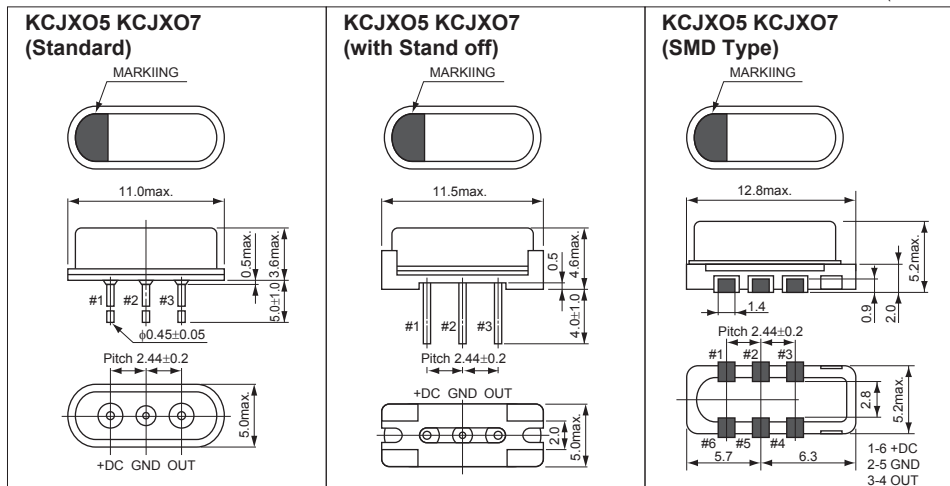

Recommended Land Pattern (Unit : mm)

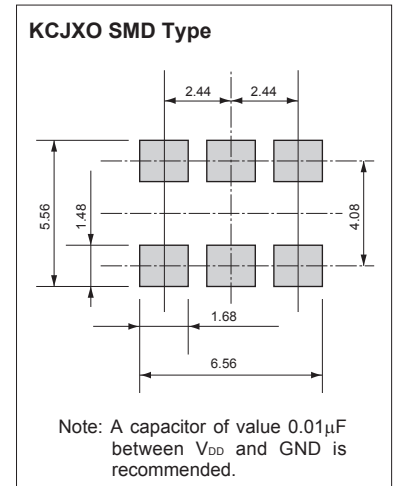

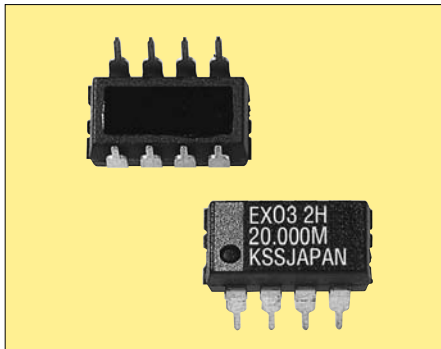

Pb Free

RoHS Compliant

Features

- Since it has a frequency dividing function, it is able to obtain a frequency division of 1/2-1/2⁸ (1/256)
- The symmetry of frequency divided output is within 50±2%
- The oscillation start time has the fast starting characteristic of being 1.5msec.or less
- The pin arrangement is DIP 8PIN
- Supply voltage V_{DD}=5.0V

Applications

- Amusement

How to Order

KCEX03- 20.000 C 5 1 B 00
① ② ③ ④ ⑤ ⑥ ⑦

- ① Type
- ② Output Frequency
- ③ Output Type (CMOS)
- ④ Supply Voltage (5.0V)
- ⑤ Frequency Tolerance
- ⑥ Symmetry/EnableFunction (40/60%, Stand-by)
- ⑦ Customer Special Model Suffix (STD Specification is "00")

Specifications

Item	Symbol	Conditions	Specifications		Units
			Min.	Max.	
Output Frequency Range	F ₀		11.0592	24.576	MHz
Frequency Tolerance (Overall)	F _{tol}		-100	+100	×10 ⁻⁶
Storage Temperature Range	T _{stg}		-40	+85	°C
Operating Temperature Range	T _{use}		-10	+70	°C
Supply Voltage	V _{DD}		4.5	5.5	V
Current Consumption	I _{DD}		—	20	mA
Symmetry	SYM	@50% V _{DD}	40	60	%
Rise / Fall Time	Tr/Tf		—	15	nS
Output Voltage-"L"	V _{OL}		—	10% V _{DD}	V
Output Voltage-"H"	V _{OH}		90% V _{DD}	—	V
Output Load	CL		—	50	pF
Start-up Time	ST		—	1.5	mS

Note: All electrical characteristics are defined at the maximum load and operating temperature range.
Please contact us for inquiries about operating temperature range, available frequencies and other conditions.

Dimensions

(Unit : mm)

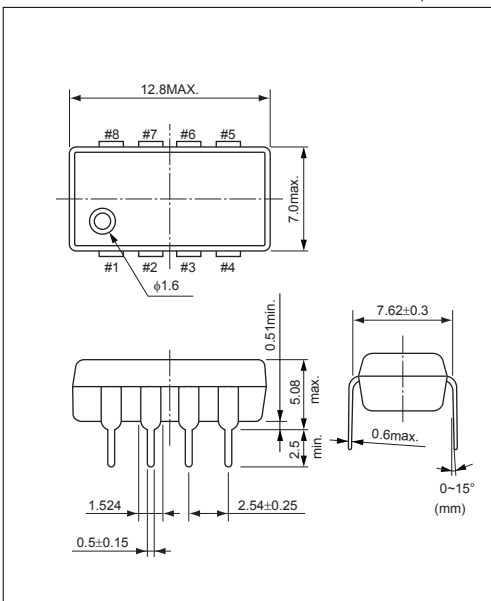

Settings of the frequency division output

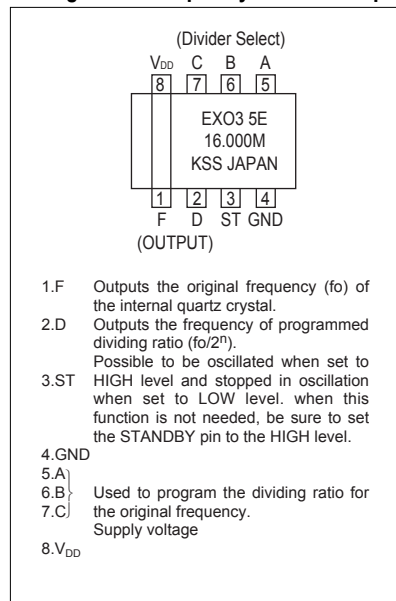

Pin connection

Input				Output	
Select	ST	F		D	
C		B	A	Original Frequency	Divided Wave form
L	L	L	H	fo clock	fo · 1/2 clock
L	L	H	H	fo clock	fo · 1/2 ² clock
L	H	L	H	fo clock	fo · 1/2 ³ clock
L	H	H	H	fo clock	fo · 1/2 ⁴ clock
H	L	L	H	fo clock	fo · 1/2 ⁵ clock
H	L	H	H	fo clock	fo · 1/2 ⁶ clock
H	H	L	H	fo clock	fo · 1/2 ⁷ clock
H	H	H	H	fo clock	fo · 1/2 ⁸ clock
—	—	—	L	L	L



Pb Free

RoHS Compliant

Features

- Miniature ceramic package
- Highly reliable with seam welding
- LV-PECL output
- Supply voltage $V_{DD}=2.5V$
- $\pm 25 \times 10^{-6}$ available

Table 1

Freq. Tol. Code	Tolerance $\times 10^{-6}$	Operating Temperature Range (°C)	Note
0	± 50	0 to +70	Standard specifications
S	± 30		
U	± 25	-40 to +85	With only certain frequencies
F	± 100		
G	± 50		

How to Order

KC5032P 125.000 P 2 0 E 00
 ① ② ③ ④ ⑤ ⑥ ⑦

- ① Type (5.0x3.2mm SMD)
- ② Output Frequency
- ③ Output Type (LV-PECL)
- ④ Supply Voltage (2.5V)
- ⑤ Frequency Tolerance (See Table 1)
- ⑥ Symmetry/ Enable Function (45/55%, Stand-by)
- ⑦ Customer Special Model Suffix (STD Specification is "00")

Packaging (Tape & Reel 1000pcs./reel)

Specifications

Item	Symbol	Conditions	Min.	Max.	Units	
Output Frequency Range	F _o		75	170	MHz	
Frequency Tolerance	F _{tol}	Initial tolerance, Operating temperature range, Rated power supply voltage change, Load change, Aging (1year @25°C), Shock and vibration	Op. Temp.: -40 to +85°C	-100	+100	$\times 10^{-6}$
			Op. Temp.: 0 to +70°C/ -40 to +85°C	-50	+50	
			Op. Temp.: 0 to +70°C/ -40 to +85°C	-30	+30	
			Op. Temp.: 0 to +70°C	-25	+25	
Storage Temperature Range	T _{stg}		-55	+125	°C	
Operating Temperature Range	T _{use}	Standard Specifications	0	+70	°C	
		Extend (Option)	-40	+85		
Max. Supply Voltage	—		-0.5	+5	V	
Supply Voltage	V _{DD}		2.375	2.625	V	
Current Consumption	I _{DD}		—	90	mA	
Stand-by Current	I _{std}		—	30	μA	
Symmetry	SYM	50 ohm @50% Output Swing	45	55	%	
Rise/Fall Time (20% V _{DD} to 80% V _{DD})	T _r /T _f	50 ohm	—	0.6	nS	
Output Voltage-"L"	V _{OL}	Op. Temp.: 0 to +85°C/ Typ. 0.800V	V _{DD} -1.810	V _{DD} -1.405	V	
		Op. Temp.: -40 to 0°C/ Typ. 0.805V	V _{DD} -1.830	V _{DD} -1.305		
Output Voltage-"H"	V _{OH}	Op. Temp.: 0 to +85°C/ Typ. 1.550V	V _{DD} -1.025	V _{DD} -0.740	V	
		Op. Temp.: -40 to 0°C/ Typ. 1.495V	V _{DD} -1.085	V _{DD} -0.880		
Output Load	L _{ECL}	LV-PECL Output	50		ohm	
Input Voltage Range	V _{IN}		0	V _{DD}	V	
Input Voltage-"L"	V _{IL}		—	30% V _{DD}	V	
Input Voltage-"H"	V _{IH}		70% V _{DD}	—	V	
Disable Time	—		—	150	nS	
Enable Time	—		—	5	mS	
Start-up Time	ST	@Minimum Operation Voltage to be 0 sec.	—	10	mS	
Deterministic Jitter (DJ)	DJ	Measured with Wavecrest DTS-2079 VIS/ 6.3.1	—	2	pS	
1Sigma jitter	1sigma		—	4	pS	
Peak to Peak Jitter	Pk-Pk		—	30	pS	

Note: All electrical characteristics are defined at the maximum load and operating temperature range. Please contact us for inquiries about operating temperature range, available frequencies and other conditions.

Dimensions

(Unit : mm)

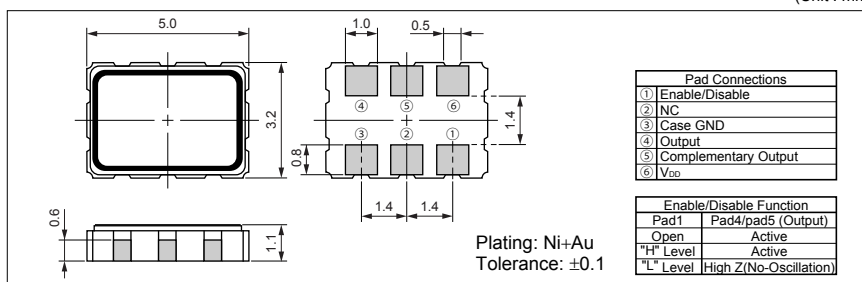

Recommended Land Pattern

(Unit : mm)

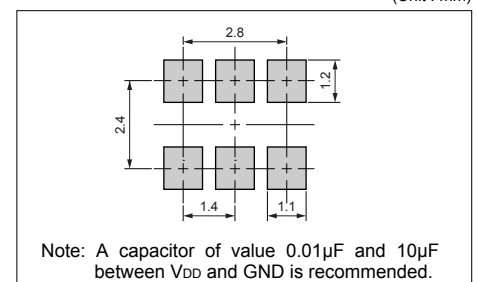



Pb Free

RoHS Compliant

Features

- Miniature ceramic package
- Highly reliable with seam welding
- LV-PECL output
- Supply voltage $V_{DD}=3.3V$
- $\pm 25 \times 10^{-6}$ available

Table 1

Freq. Tol. Code	Tol. $\times 10^{-6}$	Operating Temperature Range (°C)	Note
0	± 50	0 to +70	Standard specifications
S	± 30		
U	± 25		
F	± 100	-40 to +85	With only certain frequencies
G	± 50		

How to Order

KC5032P 125.000 P 3 0 E 00
 ① ② ③ ④ ⑤ ⑥ ⑦

- ① Type (5.0×3.2mm SMD)
- ② Output Frequency
- ③ Output Type (LV-PECL)
- ④ Supply Voltage (3.3V)
- ⑤ Frequency Tolerance (See Table 1)
- ⑥ Symmetry/ Enable Function (45/55%, Stand-by)
- ⑦ Customer Special Model Suffix (STD Specification is "00")

Packaging (Tape & Reel 1000pcs./reel)

Specifications

Item	Symbol	Conditions	Min.	Max.	Units	
Output Frequency Range	Fo		75	190	MHz	
Frequency Tolerance	F _{tol}	Initial tolerance, Operating temperature range, Rated power supply voltage change, Load change, Aging (1year @25°C), Shock and vibration	Op. Temp.: -40 to +85°C	-100	+100	$\times 10^{-6}$
			Op. Temp.: 0 to +70°C/ -40 to +85°C	-50	+50	
			Op. Temp.: 0 to +70°C/ -40 to +85°C	-30	+30	
			Op. Temp.: 0 to +70°C	-25	+25	
Storage Temperature Range	T _{stg}		-55	+125	°C	
Operating Temperature Range	T _{use}	Standard Specifications	0	+70	°C	
		Extend (Option)	-40	+85		
Max. Supply Voltage	—		-0.5	+5	V	
Supply Voltage	V _{DD}	Freq. Tol.Code: 0, S, F	2.97	3.63	V	
		Freq. Tol.Code: U, G	3.14	3.46		
Current Consumption	I _{DD}		—	90	mA	
Stand-by Current	I _{std}		—	30	μA	
Symmetry	SYM	50 ohm @50% Output Swing	45	55	%	
Rise/Fall Time (20% V _{cc} to 80% V _{cc})	Tr/Tf	50 ohm	—	0.6	nS	
Output Voltage-"L"	V _{OL}	Op. Temp.: 0 to +85°C/ Typ. 1.600V	V _{DD} -1.810	V _{DD} -1.620	V	
		Op. Temp.: -40 to 0°C/ Typ. 1.605V	V _{DD} -1.830	V _{DD} -1.555		
Output Voltage-"H"	V _{OH}	Op. Temp.: 0 to +85°C/ Typ. 2.350V	V _{DD} -1.025	V _{DD} -0.880	V	
		Op. Temp.: -40 to 0°C/ Typ. 2.295V	V _{DD} -1.085	V _{DD} -0.900		
Output Load	L _{ECL}	LV-PECL Output	50		ohm	
Input Voltage Range	V _{IN}		0	V _{CC}	V	
Input Voltage-"L"	V _{IL}		—	30% V _{DD}	V	
Input Voltage-"H"	V _{IH}		70% V _{DD}	—	V	
Disable Time	—		—	150	nS	
Enable Time	—		—	5	mS	
Start-up Time	ST	@Minimum Operation Voltage to be 0 sec.	—	10	mS	
Deterministic Jitter (DJ)	DJ	Measured with Wavecrest DTS-2079 VIS/ 6.3.1	—	2	pS	
1Sigma jitter	1sigma		—	4	pS	
Peak to Peak Jitter	Pk-Pk		—	30	pS	

Note: All electrical characteristics are defined at the maximum load and operating temperature range.
 Please contact us for inquiries about operating temperature range, available frequencies and other conditions.

Dimensions

(Unit : mm)

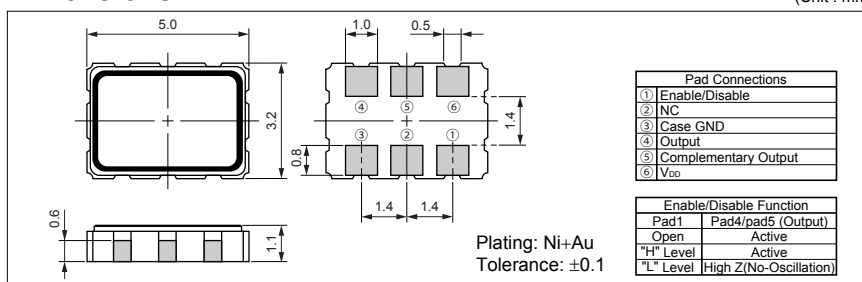

Recommended Land Pattern

(Unit : mm)

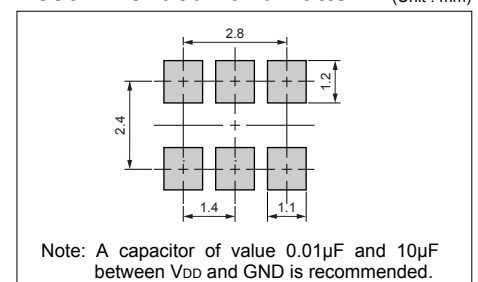

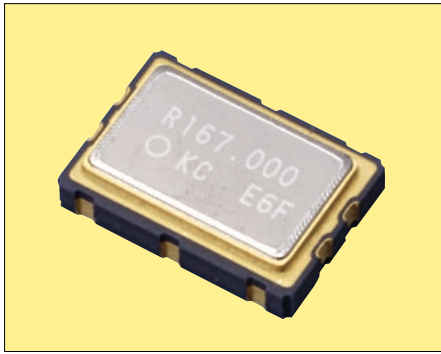

Pb Free

RoHS Compliant

Features

- Miniature ceramic package
- Highly reliable with seam welding
- LV-PECL output
- Supply voltage $V_{DD}=2.5V$
- $\pm 25 \times 10^{-6}$ available

Table 1

Freq. Tol. Code	Tol. $\times 10^{-6}$	Operating Temperature Range (°C)	Note
0	± 50	0 to +70	Standard specifications
S	± 30		
U	± 25		
F	± 100	-40 to +85	With only certain frequencies
G	± 50		

How to Order

KC7050P 125.000 P 2 0 E 00
 ① ② ③ ④ ⑤ ⑥ ⑦

- ① Type (7.0×5.0mm SMD)
- ② Output Frequency
- ③ Output Type (LV-PECL)
- ④ Supply Voltage (2.5V)
- ⑤ Frequency Tolerance (See Table 1)
- ⑥ Symmetry/ Enable Function (45/55%, Stand-by)
- ⑦ Customer Special Model Suffix (STD Specification is "00")

Packaging (Tape & Reel 1000pcs./reel)

Specifications

Item	Symbol	Conditions	Min.	Max.	Units	
Output Frequency Range	Fo		75	170	MHz	
Frequency Tolerance	F _{tol}	Initial tolerance, Operating temperature range, Rated power supply voltage change, Load change, Aging (1year @25°C), Shock and vibration	Op. Temp.: -40 to +85°C	-100	+100	$\times 10^{-6}$
			Op. Temp.: 0 to +70°C / -40 to +85°C	-50	+50	
			Op. Temp.: 0 to +70°C / -40 to +85°C	-30	+30	
			Op. Temp.: 0 to +70°C	-25	+25	
Storage Temperature Range	T _{stg}		-55	+125	°C	
Operating Temperature Range	T _{use}	Standard Specifications	0	+70	°C	
		Extend (Option)	-40	+85		
Max. Supply Voltage	—		-0.5	+5	V	
Supply Voltage	V _{DD}		2.375	2.625	V	
Current Consumption	I _{DD}		—	90	mA	
Stand-by Current	I _{std}		—	30	μA	
Symmetry	SYM	50 ohm @50% Output Swing	45	55	%	
Rise/Fall Time (20% V _{DD} to 80% V _{DD})	Tr/Tf	50 ohm	—	0.6	nS	
Output Voltage-"L"	V _{OL}	Op. Temp.: 0 to +85°C/ Typ. 0.800V	V _{DD} -1.810	V _{DD} -1.405	V	
		Op. Temp.: -40 to 0°C/ Typ. 0.805V	V _{DD} -1.830	V _{DD} -1.305		
Output Voltage-"H"	V _{OH}	Op. Temp.: 0 to +85°C/ Typ. 1.550V	V _{DD} -1.025	V _{DD} -0.740	V	
		Op. Temp.: -40 to 0°C/ Typ. 1.495V	V _{DD} -1.085	V _{DD} -0.800		
Output Load	L _{ECL}	LV-PECL Output	50		ohm	
Input Voltage Range	V _{IN}		0	V _{DD}	V	
Input Voltage-"L"	V _{IL}		—	30% V _{DD}	V	
Input Voltage-"H"	V _{IH}		70% V _{DD}	—	V	
Disable Time	—		—	150	nS	
Enable Time	—		—	5	mS	
Start-up Time	ST	@Minimum Operation Voltage to be 0 sec.	—	10	mS	
Deterministic Jitter (DJ)	DJ	Measured with Wavecrest DTS-2079 VIS/ 6.3.1	—	2	pS	
1Sigma jitter	1sigma		—	4	pS	
Peak to Peak Jitter	Pk-Pk		—	30	pS	

Note: All electrical characteristics are defined at the maximum load and operating temperature range. Please contact us for inquiries about operating temperature range, available frequencies and other conditions.

Dimensions

(Unit : mm)

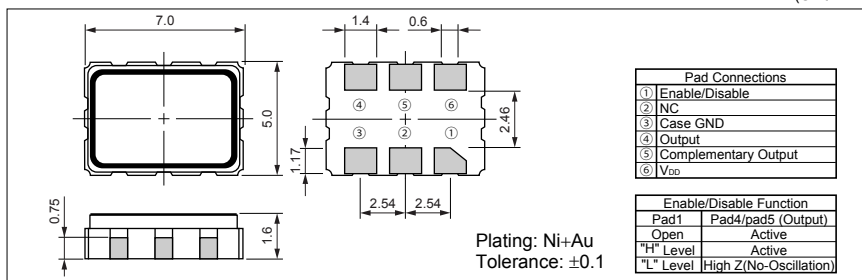

Recommended Land Pattern

(Unit : mm)

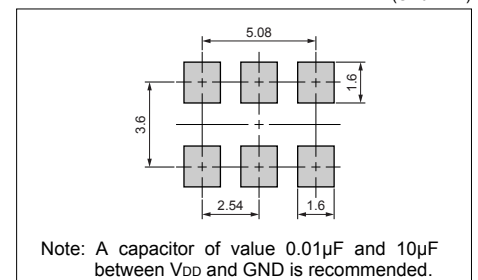



Pb Free

RoHS Compliant

Features

- Miniature ceramic package
- Highly reliable with seam welding
- LV-PECL output
- Supply voltage $V_{DD}=3.3V$
- $\pm 25 \times 10^{-6}$ available

Table 1

Freq. Tol. Code	Tol. $\times 10^{-6}$	Operating Temperature Range (°C)	Note
0	± 50	0 to +70	Standard specifications
S	± 30		
U	± 25		
F	± 100	-40 to +85	With only certain frequencies
G	± 50		

How to Order

KC7050P 125.000 P 3 0 E 00
 ① ② ③ ④ ⑤ ⑥ ⑦

- ① Type (7.0×5.0mm SMD)
- ② Output Frequency
- ③ Output Type (LV-PECL)
- ④ Supply Voltage (3.3V)
- ⑤ Frequency Tolerance (See Table 1)
- ⑥ Symmetry/ Enable Function (45/55%, Stand-by)
- ⑦ Customer Special Model Suffix (STD Specification is "00")

Packaging (Tape & Reel 1000pcs./reel)

Specifications

Item	Symbol	Conditions	Min.	Max.	Units	
Output Frequency Range	Fo		75	190	MHz	
Frequency Tolerance	F _{tol}	Initial tolerance, Operating temperature range, Rated power supply voltage change, Load change, Aging (1year @25°C), Shock and vibration	Op. Temp.: -40 to +85°C	-100	+100	$\times 10^{-6}$
			Op. Temp.: 0 to +70°C / -40 to +85°C	-50	+50	
			Op. Temp.: 0 to +70°C / -40 to +85°C	-30	+30	
			Op. Temp.: 0 to +70°C	-25	+25	
Storage Temperature Range	T _{stg}		-55	+125	°C	
Operating Temperature Range	T _{use}	Standard Specifications	0	+70	°C	
		Extend (Option)	-40	+85		
Max. Supply Voltage	—		-0.5	+5	V	
Supply Voltage	V _{DD}	Freq. Tol.Code: 0, S, F	2.97	3.63	V	
		Freq. Tol.Code: U, G	3.14	3.46		
Current Consumption	I _{DD}		—	90	mA	
Stand-by Current	I _{std}		—	30	μA	
Symmetry	SYM	50 ohm @50% Output Swing	45	55	%	
Rise/Fall Time (20% V _{CC} to 80% V _{CC})	Tr/Tf	50 ohm	—	0.6	nS	
Output Voltage-"L"	V _{OL}	Op. Temp.: 0 to +85°C / Typ. 1.600V	V _{DD} -1.810	V _{DD} -1.620	V	
		Op. Temp.: -40 to 0°C / Typ. 1.605V	V _{DD} -1.830	V _{DD} -1.555		
Output Voltage-"H"	V _{OH}	Op. Temp.: 0 to +85°C / Typ. 2.350V	V _{DD} -1.025	V _{DD} -0.880	V	
		Op. Temp.: -40 to 0°C / Typ. 2.295V	V _{DD} -1.085	V _{DD} -0.900		
Output Load	L _{ECL}	LV-PECL Output	50		ohm	
Input Voltage Range	V _{IN}		0	V _{DD}	V	
Input Voltage-"L"	V _{IL}		—	30% V _{DD}	V	
Input Voltage-"H"	V _{IH}		70% V _{DD}	—	V	
Disable Time	—		—	150	nS	
Enable Time	—		—	5	mS	
Start-up Time	ST	@Minimum Operation Voltage to be 0 sec.	—	10	mS	
Deterministic Jitter (DJ)	DJ	Measured with Wavecrest DTS-2079 VIS/ 6.3.1	—	2	pS	
1Sigma jitter	1sigma		—	4	pS	
Peak to Peak Jitter	Pk-Pk		—	30	pS	

Note: All electrical characteristics are defined at the maximum load and operating temperature range. Please contact us for inquiries about operating temperature range, available frequencies and other conditions.

Dimensions

(Unit : mm)

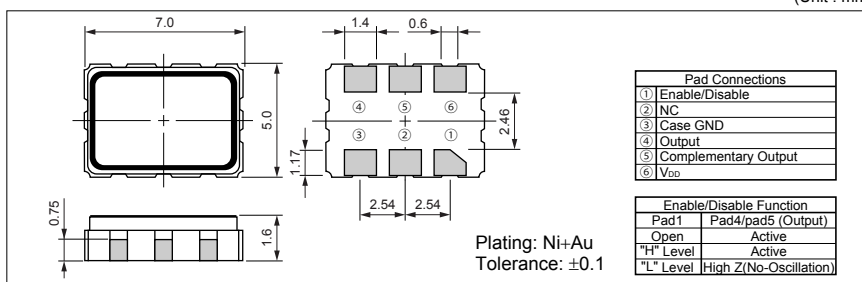

Recommended Land Pattern

(Unit : mm)

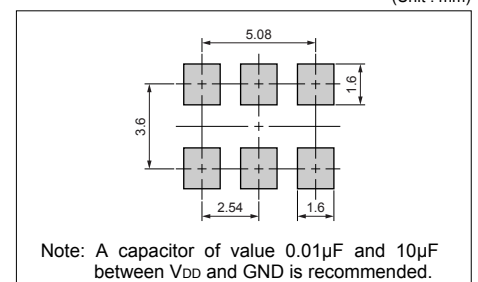



Pb Free

RoHS Compliant

Features

- Low voltage 2.5V
- Low jitter
- LV-PECL output
- Operation at fundamental high frequency

How to Order

KC7050S 155.520 P 2 1 E 00
 ① ② ③④⑤⑥ ⑦

- ① Type (7.0×5.0mm SMD)
- ② Output Frequency
- ③ Output Type (PECL)
- ④ Supply Voltage (2.5V)
- ⑤ Frequency Tolerance (See Table 1)
- ⑥ Symmetry/Enable Function (45/55%, Stand-by)
- ⑦ Customer Special Model Suffix (STD Specification is "00")

Packaging (Tape & Reel 1000pcs./reel)

Table 1

Freq. Tol. Code	×10 ⁻⁶	Operating Temperature Range (°C)	Note
1	±100	0 to +70	Standard specifications

Specifications

Item	Symbol	Conditions	Min.	Max.	Units
Output Frequency Range	F _o		50	700	MHz
Frequency Tolerance	F _{tol}	Initial tolerance, Operating temperature range, Rated power supply voltage change, Load change, Aging (1year @25°C), Shock and vibration	-100	+100	×10 ⁻⁶
Storage Temperature Range	T _{stg}		-55	+125	°C
Operating Temperature Range	T _{use}	Standard Specifications	0	+70	°C
Max. Supply Voltage	—		-0.5	+5	V
Supply Voltage	V _{cc}		2.38	2.62	V
Current Consumption (Standard Loaded)	I _{cc}		—	60	mA
Symmetry	SYM	50MHz≤F _o ≤350MHz 350MHz<F _o ≤700MHz	45 40	55 60	%
Rise/ Fall Time (20% V _{cc} to 80% V _{cc} Standard Loaded)	Tr/Tf	50MHz≤F _o ≤400MHz 400MHz<F _o ≤700MHz	— —	600 400	pS
Output Voltage-"L"	V _{OL}		—	1.195	V
Output Voltage-"H"	V _{OH}		1.415	—	V
Output Load (PECL)	L _{ECL}	PECL 50Ω @Terminated V _{cc} -2V	49.5	50.5	ohm
Input Voltage Range	V _{IN}		0	V _{cc}	V
Input Voltage-"L"	V _{IL}		—	30% V _{cc}	V
Input Voltage-"H"	V _{IH}		70% V _{cc}	—	V
Disable Time	—		—	200	nS
Enable Time	—		—	2	mS
Start-up Time	ST	@ Minimum Operation Voltage to be 0 sec.	—	10	mS
Deterministic Jitter (DJ)	DJ		0.2 typ.		ps
1 Sigma Jitter	1 Sigma	Measured with Wavecrest DTS-2079 VIS / 6.3.1	3 typ.		ps
Peak to Peak Jitter	Pk-Pk		20 typ.		ps

Note: All electrical characteristics are defined at the maximum load and operating temperature range.
 Please contact us for inquiries about operating temperature range, available frequencies and other conditions.

Dimensions

(Unit : mm)

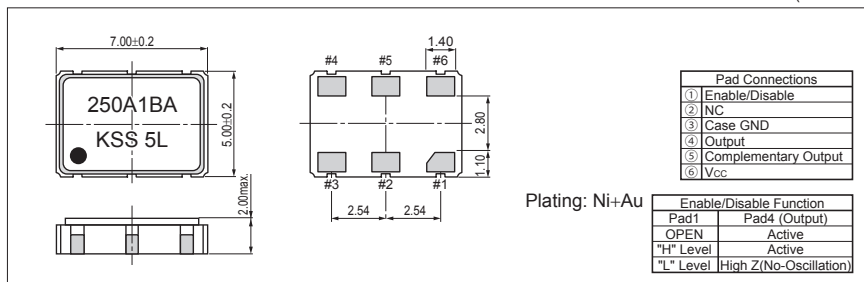

Recommended Land Pattern

(Unit : mm)

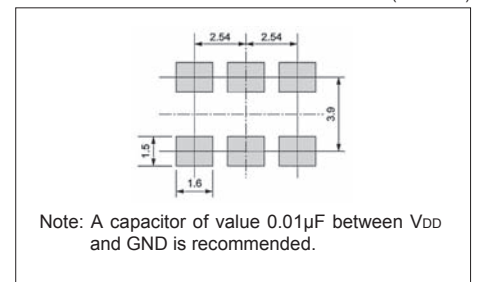

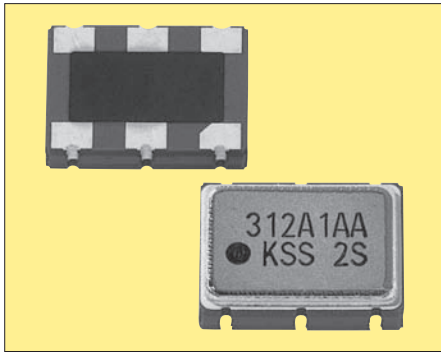

Pb Free

RoHS Compliant

Features

- Low jitter
- Complementary LV-PECL outputs
- Operation at fundamental high frequency

Table 1

Freq. Tol. Code	×10 ⁻⁶	Operating Temperature Range (°C)	Note
1	±100	0 to +70	Standard specifications

How to Order

KC7050S 312.500 P 3 1 E 00
 ① ② ③④⑤⑥ ⑦

- ① Type (7.0×5.0mm SMD)
- ② Output Frequency
- ③ Output Type (PECL)
- ④ Supply Voltage (3.3V)
- ⑤ Frequency Tolerance (See Table 1)
- ⑥ Symmetry/Enable Function (45/55%, Stand-by)
- ⑦ Customer Special Model Suffix (STD Specification is "00")

Packaging (Tape & Reel 1000pcs./reel)

Specifications

Item	Symbol	Conditions	Min.	Max.	Units
Output Frequency Range	F _o		50	700	MHz
Frequency Tolerance	F _{tol}	Initial tolerance, Operating temperature range, Rated power supply voltage change, Load change, Aging (1year @25°C), Shock and vibration	-100	+100	×10 ⁻⁶
Storage Temperature Range	T _{stg}		-55	+125	°C
Operating Temperature Range	T _{use}	Standard Specifications	0	+70	°C
Max. Supply Voltage	—		-0.5	+5	V
Supply Voltage	V _{cc}		3.14	3.46	V
Current Consumption (Standard Loaded)	I _{cc}		—	60	mA
Symmetry	SYM	50MHz≤F _o ≤350MHz	45	55	%
		350MHz<F _o ≤700MHz	40	60	
Rise/ Fall Time (20% V _{cc} to 80% V _{cc} Standard Loaded)	Tr/Tf	50MHz≤F _o ≤400MHz	—	600	pS
		400MHz<F _o ≤700MHz	—	400	
Output Voltage-"L"	V _{OL}		—	1.68	V
Output Voltage-"H"	V _{OH}		2.275	—	V
Output Load (PECL)	L _{ECL}	PECL 50Ω @Terminated V _{cc} -2V	49.5	50.5	ohm
Input Voltage Range	V _{IN}		0	V _{cc}	V
Input Voltage-"L"	V _{IL}		—	30% V _{cc}	V
Input Voltage-"H"	V _{IH}		70% V _{cc}	—	V
Disable Time	—		—	200	nS
Enable Time	—		—	2	mS
Start-up Time	ST	@ Minimum Operation Voltage to be 0 sec.	—	10	mS
Deterministic Jitter (DJ)	DJ		0.2 typ.		ps
1 Sigma Jitter	1 Sigma	Measured with Wavecrest DTS-2079 VIS / 6.3.1	3 typ.		ps
Peak to Peak Jitter	Pk-Pk		20 typ.		ps

Note: All electrical characteristics are defined at the maximum load and operating temperature range.
 Please contact us for inquiries about operating temperature range, available frequencies and other conditions.

Dimensions

(Unit : mm)

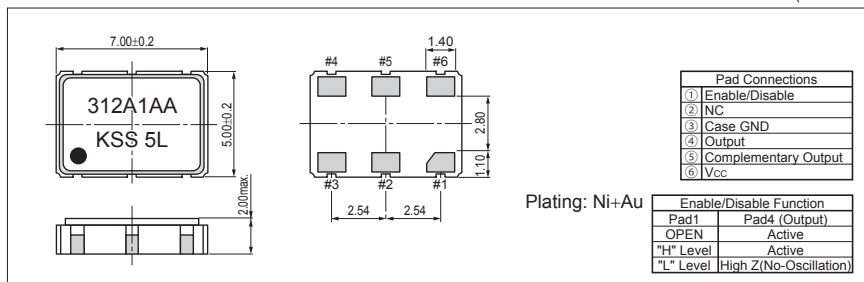

Recommended Land Pattern

(Unit : mm)

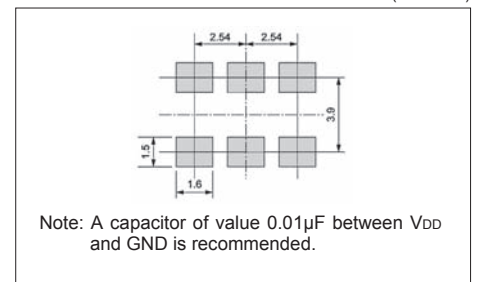



Pb Free

RoHS Compliant

Features

- Miniature ceramic package
- Highly reliable with seam welding
- LVDS output
- Supply voltage $V_{DD}=2.5V$
- $\pm 25 \times 10^{-6}$ available

Table 1

Freq. Tol. Code	Tol. $\times 10^{-6}$	Operating Temperature Range (°C)	Note
0	± 50	-10 to +70	Standard specifications
S	± 30		
U	± 25		
F	± 100	-40 to +85	With only certain frequencies
G	± 50		

How to Order

KC5032P 125.000 L 2 0 E 00
 ① ② ③ ④ ⑤ ⑥ ⑦

- ① Type (5.0×3.2mm SMD)
- ② Output Frequency
- ③ Output Type (LVDS)
- ④ Supply Voltage (2.5V)
- ⑤ Frequency Tolerance (See Table 1)
- ⑥ Symmetry/ Enable Function (45/55%, Stand-by)
- ⑦ Customer Special Model Suffix (STD Specification is "00")

Packaging (Tape & Reel 1000pcs./reel)

Specifications

Item	Symbol	Conditions	Min.	Max.	Units	
Output Frequency Range	Fo		75	170	MHz	
Frequency Tolerance	F _{tol}	Initial tolerance, Operating temperature range, Rated power supply voltage change, Load change, Aging (1year @25°C), Shock and vibration	Op. Temp.: -40 to +85°C	-100	+100	$\times 10^{-6}$
			Op. Temp.: -10 to +70°C/ -40 to +85°C	-50	+50	
			Op. Temp.: -10 to +70°C/ -40 to +85°C	-30	+30	
			Op. Temp.: -10 to +70°C	-25	+25	
Storage Temperature Range	T _{stg}		-55	+125	°C	
Operating Temperature Range	T _{use}	Standard Specifications	0	+70	°C	
		Extend (Option)	-40	+85		
Max. Supply Voltage	—		-0.5	+5	V	
Supply Voltage	V _{DD}		2.375	2.625	V	
Current Consumption	I _{DD}		—	70	mA	
Stand-by Current	I _{std}		—	30	μA	
Symmetry	SYM	100 ohm @50% Output Swing	45	55	%	
Rise/Fall Time (20% V _{CC} to 80% V _{CC})	Tr/Tf	100 ohm	—	0.6	nS	
Output Voltage-"L"	V _{OL}	Typ. 1.1V	0.9	—	V	
Output Voltage-"H"	V _{OH}	Typ. 1.43V	—	1.6	V	
Differential Output Voltage	V _{OD}	Typ. 330mV	247	454	mV	
Differential Output Voltage Error	dV _{OD}	dV _{OD} = V _{OD1} -V _{OD2}	—	50	mV	
Offset Voltage	V _{OS}	Typ. 1.25V	1.125	1.375	V	
Offset Voltage Error	dV _{OS}	dV _{OS} = V _{OS1} -V _{OS2}	—	50	mV	
Output Load	L _{LVDS}	LVDS Output	100		ohm	
Input Voltage Range	V _{IN}		0	V _{DD}	V	
Input Voltage-"L"	V _{IL}		—	30% V _{DD}	V	
Input Voltage-"H"	V _{IH}		70% V _{DD}	—	V	
Disable Time	—		—	200	nS	
Enable Time	—		—	5	mS	
Start-up Time	ST	@Minimum Operation Voltage to be 0 sec.	—	10	mS	
Deterministic Jitter (DJ)	DJ		—	2	pS	
1Sigma jitter	1sigma	Measured with Wavecrest DTS-2079 VIS/ 6.3.1	—	4	pS	
Peak to Peak Jitter	Pk-Pk		—	30	pS	

Note: All electrical characteristics are defined at the maximum load and operating temperature range.
 Please contact us for inquiries about operating temperature range, available frequencies and other conditions.

Dimensions

(Unit : mm)

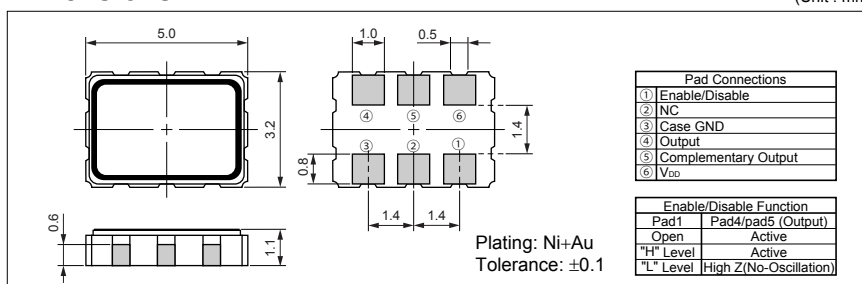

Recommended Land Pattern

(Unit : mm)

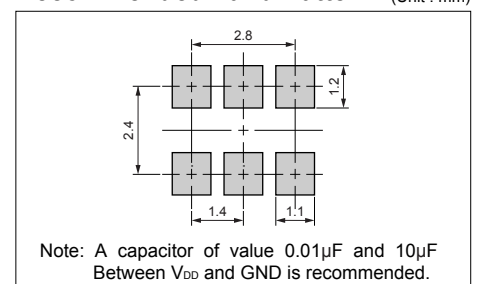



Pb Free

RoHS Compliant

Features

- Miniature ceramic package
- Highly reliable with seam welding
- LVDS output
- Supply voltage $V_{DD}=3.3V$
- $\pm 25 \times 10^{-6}$ available

Table 1

Freq. Tol. Code	Tol. $\times 10^{-6}$	Operating Temperature Range (°C)	Note
0	± 50	-10 to +70	Standard specifications
S	± 30		
U	± 25		
F	± 100	-40 to +85	With only certain frequencies
G	± 50		

How to Order

KC5032P 125.000 L 3 0 E 00
 ① ② ③ ④ ⑤ ⑥ ⑦

- ① Type (5.0×3.2mm SMD)
- ② Output Frequency
- ③ Output Type (LVDS)
- ④ Supply Voltage (3.3V)
- ⑤ Frequency Tolerance (See Table 1)
- ⑥ Symmetry/ Enable Function (45/55%, Stand-by)
- ⑦ Customer Special Model Suffix (STD Specification is "00")

Packaging (Tape & Reel 1000pcs./reel)

Specifications

Item	Symbol	Conditions	Min.	Max.	Units	
Output Frequency Range	Fo		75	170	MHz	
Frequency Tolerance	F _{tol}	Initial tolerance, Operating temperature range, Rated power supply voltage change, Load change, Aging (1year @25°C), Shock and vibration	Op. Temp.: -40 to +85°C	-100	+100	$\times 10^{-6}$
			Op. Temp.: -10 to +70°C/ -40 to +85°C	-50	+50	
			Op. Temp.: -10 to +70°C/ -40 to +85°C	-30	+30	
			Op. Temp.: -10 to +70°C	-25	+25	
Storage Temperature Range	T _{stg}		-55	+125	°C	
Operating Temperature Range	T _{use}	Standard Specifications	0	+70	°C	
		Extend (Option)	-40	+85		
Max. Supply Voltage	—		-0.5	+5	V	
Supply Voltage	V _{DD}	Freq. Tol. Code: 0, S, F	2.97	3.63	V	
		Freq. Tol. Code: U, G	3.14	3.46		
Current Consumption	I _{DD}		—	70	mA	
Stand-by Current	I _{std}		—	30	μA	
Symmetry	SYM	100 ohm @50% Output Swing	45	55	%	
Rise/Fall Time (20% V _{CC} to 80% V _{CC})	Tr/Tf	100 ohm	—	0.6	nS	
Output Voltage-"L"	V _{OL}	Typ. 1.1V	0.9	—	V	
Output Voltage-"H"	V _{OH}	Typ. 1.43V	—	1.6	V	
Differential Output Voltage	V _{OD}	Typ. 330mV	247	454	mV	
Differential Output Voltage Error	dV _{OD}	dV _{OD} = V _{OD1} -V _{OD2}	—	50	mV	
Offset Voltage	V _{OS}	Typ. 1.25V	1.125	1.375	V	
Offset Voltage Error	dV _{OS}	dV _{OS} = V _{OS1} -V _{OS2}	—	50	mV	
Output Load	L _{LVDS}	LVDS Output	100		ohm	
Input Voltage Range	V _{IN}		0	V _{DD}	V	
Input Voltage-"L"	V _{IL}		—	30% V _{DD}	V	
Input Voltage-"H"	V _{IH}		70% V _{DD}	—	V	
Disable Time	—		—	200	nS	
Enable Time	—		—	5	mS	
Start-up Time	ST	@Minimum Operation Voltage to be 0 sec.	—	10	mS	
Deterministic Jitter (DJ)	DJ		—	2	pS	
1Sigma jitter	1sigma	Measured with Wavecrest DTS-2079 V/IS/ 6.3.1	—	4	pS	
Peak to Peak Jitter	Pk-Pk		—	30	pS	

Note: All electrical characteristics are defined at the maximum load and operating temperature range.
 Please contact us for inquiries about operating temperature range, available frequencies and other conditions.

Dimensions

(Unit : mm)

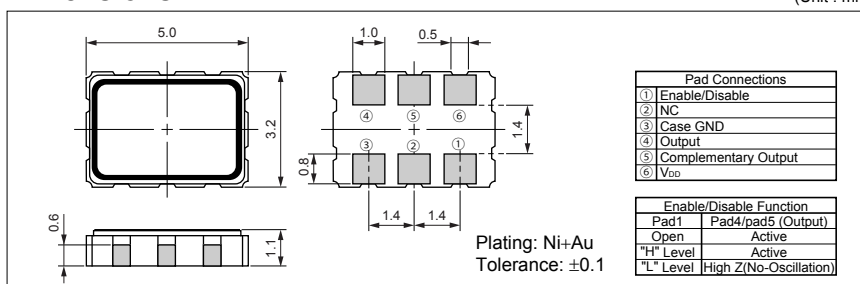

Recommended Land Pattern

(Unit : mm)

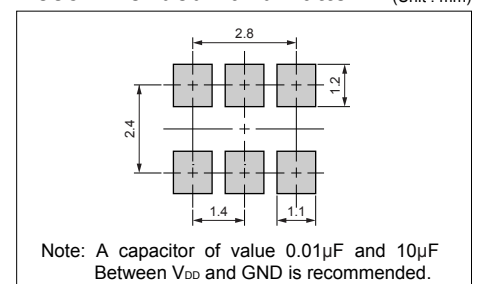



Pb Free

RoHS Compliant

Features

- Miniature ceramic package
- Highly reliable with seam welding
- LVDS output
- Supply voltage $V_{DD}=2.5V$
- $\pm 25 \times 10^{-6}$ available

Table 1

Freq. Tol. Code	Tol. $\times 10^{-6}$	Operating Temperature Range (°C)	Note
0	± 50	-10 to +70	Standard specifications
S	± 30		
U	± 25		
F	± 100	-40 to +85	With only certain frequencies
G	± 50		

How to Order

KC7050P 125.000 L 2 0 E 00
 ① ② ③ ④ ⑤ ⑥ ⑦

- ① Type (7.0×5.0mm SMD)
- ② Output Frequency
- ③ Output Type (LVDS)
- ④ Supply Voltage (2.5V)
- ⑤ Frequency Tolerance (See Table 1)
- ⑥ Symmetry/ Enable Function (45/55%, Stand-by)
- ⑦ Customer Special Model Suffix (STD Specification is "00")

Packaging (Tape & Reel 1000pcs./reel)

Specifications

Item	Symbol	Conditions	Min.	Max.	Units	
Output Frequency Range	Fo		75	170	MHz	
Frequency Tolerance	F _{tol}	Initial tolerance, Operating temperature range, Rated power supply voltage change, Load change, Aging (1year @25°C), Shock and vibration	Op. Temp.: -40 to +85°C	-100	+100	$\times 10^{-6}$
			Op. Temp.: -10 to +70°C/ -40 to +85°C	-50	+50	
			Op. Temp.: -10 to +70°C/ -40 to +85°C	-30	+30	
			Op. Temp.: -10 to +70°C	-25	+25	
Storage Temperature Range	T _{stg}		-55	+125	°C	
Operating Temperature Range	T _{use}	Standard Specifications	0	+70	°C	
		Extend (Option)	-40	+85		
Max. Supply Voltage	—		-0.5	+5	V	
Supply Voltage	V _{DD}		2.375	2.625	V	
Current Consumption	I _{DD}		—	70	mA	
Stand-by Current	I _{std}		—	30	μA	
Symmetry	SYM	100 ohm @50% Output Swing	45	55	%	
Rise/Fall Time (20% V _{CC} to 80% V _{CC})	Tr/Tf	100 ohm	—	0.6	nS	
Output Voltage-"L"	V _{OL}	Typ. 1.1V	0.9	—	V	
Output Voltage-"H"	V _{OH}	Typ. 1.43V	—	1.6	V	
Differential Output Voltage	V _{OD}	Typ. 330mV	247	454	mV	
Differential Output Voltage Error	dV _{OD}	dV _{OD} = V _{OD1} -V _{OD2}	—	50	mV	
Offset Voltage	V _{OS}	Typ. 1.25V	1.125	1.375	V	
Offset Voltage Error	dV _{OS}	dV _{OS} = V _{OS1} -V _{OS2}	—	50	mV	
Output Load	L _{LVDS}	LVDS Output	100		ohm	
Input Voltage Range	V _{IN}		0	V _{DD}	V	
Input Voltage-"L"	V _{IL}		—	30% V _{DD}	V	
Input Voltage-"H"	V _{IH}		70% V _{DD}	—	V	
Disable Time	—		—	200	nS	
Enable Time	—		—	5	mS	
Start-up Time	ST	@Minimum Operation Voltage to be 0 sec.	—	10	mS	
Deterministic Jitter (DJ)	DJ	Measured with Wavecrest DTS-2079 VIS/ 6.3.1	—	2	pS	
1Sigma jitter	1sigma		—	4	pS	
Peak to Peak Jitter	Pk-Pk		—	30	pS	

Note: All electrical characteristics are defined at the maximum load and operating temperature range.
 Please contact us for inquiries about operating temperature range, available frequencies and other conditions.

Dimensions

(Unit : mm)

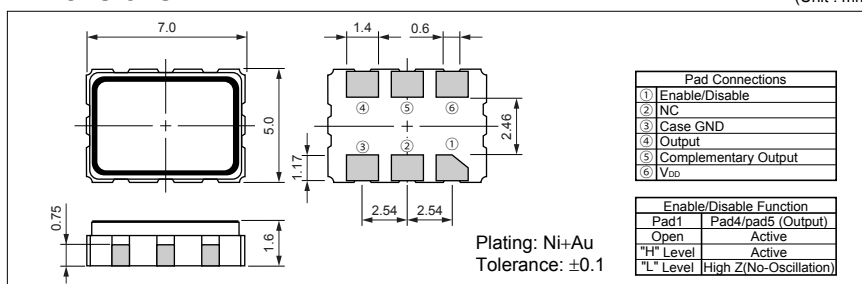

Recommended Land Pattern (Unit : mm)

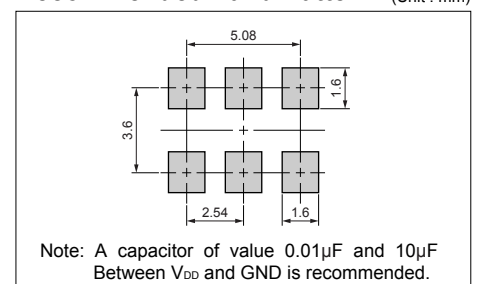



Pb Free

RoHS Compliant

Features

- Miniature ceramic package
- Highly reliable with seam welding
- LVDS output
- Supply voltage $V_{DD}=3.3V$
- $\pm 25 \times 10^{-6}$ available

Table 1

Freq. Tol. Code	Tol. $\times 10^{-6}$	Operating Temperature Range (°C)	Note
0	± 50	-10 to +70	Standard specifications
S	± 30		
U	± 25		
F	± 100	-40 to +85	With only certain frequencies
G	± 50		

How to Order

KC7050P 125.000 L 3 0 E 00
 ① ② ③ ④ ⑤ ⑥ ⑦

- ① Type (7.0×5.0mm SMD)
- ② Output Frequency
- ③ Output Type (LVDS)
- ④ Supply Voltage (3.3V)
- ⑤ Frequency Tolerance (See Table 1)
- ⑥ Symmetry/ Enable Function (45/55%, Stand-by)
- ⑦ Customer Special Model Suffix (STD Specification is "00")

Packaging (Tape & Reel 1000pcs./reel)

Specifications

Item	Symbol	Conditions	Min.	Max.	Units	
Output Frequency Range	Fo		75	170	MHz	
Frequency Tolerance	F _{tol}	Initial tolerance, Operating temperature range, Rated power supply voltage change, Load change, Aging (1year @25°C), Shock and vibration	Op. Temp.: -40 to +85°C	-100	+100	$\times 10^{-6}$
			Op. Temp.: -10 to +70°C/ -40 to +85°C	-50	+50	
			Op. Temp.: -10 to +70°C/ -40 to +85°C	-30	+30	
			Op. Temp.: -10 to +70°C	-25	+25	
Storage Temperature Range	T _{stg}		-55	+125	°C	
Operating Temperature Range	T _{use}	Standard Specifications	0	+70	°C	
		Extend (Option)	-40	+85		
Max. Supply Voltage	—		-0.5	+5	V	
Supply Voltage	V _{DD}	Freq. Tol. Code: 0, S, F	2.97	3.63	V	
		Freq. Tol. Code: U, G	3.14	3.46		
Current Consumption	I _{DD}		—	70	mA	
Stand-by Current	I _{std}		—	30	μA	
Symmetry	SYM	100 ohm @50% Output Swing	45	55	%	
Rise/Fall Time (20% V _{CC} to 80% V _{CC})	Tr/Tf	100 ohm	—	0.6	nS	
Output Voltage-"L"	V _{OL}	Typ. 1.1V	0.9	—	V	
Output Voltage-"H"	V _{OH}	Typ. 1.43V	—	1.6	V	
Differential Output Voltage	V _{OD}	Typ. 330mV	247	454	mV	
Differential Output Voltage Error	dV _{OD}	dV _{OD} = V _{OD1} -V _{OD2}	—	50	mV	
Offset Voltage	V _{OS}	Typ. 1.25V	1.125	1.375	V	
Offset Voltage Error	dV _{OS}	dV _{OS} = V _{OS1} -V _{OS2}	—	50	mV	
Output Load	L _{LVDS}	LVDS Output	100		ohm	
Input Voltage Range	V _{IN}		0	V _{DD}	V	
Input Voltage-"L"	V _{IL}		—	30% V _{DD}	V	
Input Voltage-"H"	V _{IH}		70% V _{DD}	—	V	
Disable Time	—		—	200	nS	
Enable Time	—		—	5	mS	
Start-up Time	ST	@Minimum Operation Voltage to be 0 sec.	—	10	mS	
Deterministic Jitter (DJ)	DJ		—	2	pS	
1Sigma jitter	1sigma	Measured with Wavecrest DTS-2079 VIS/ 6.3.1	—	4	pS	
Peak to Peak Jitter	Pk-Pk		—	30	pS	

Note: All electrical characteristics are defined at the maximum load and operating temperature range.
 Please contact us for inquiries about operating temperature range, available frequencies and other conditions.

Dimensions

(Unit : mm)

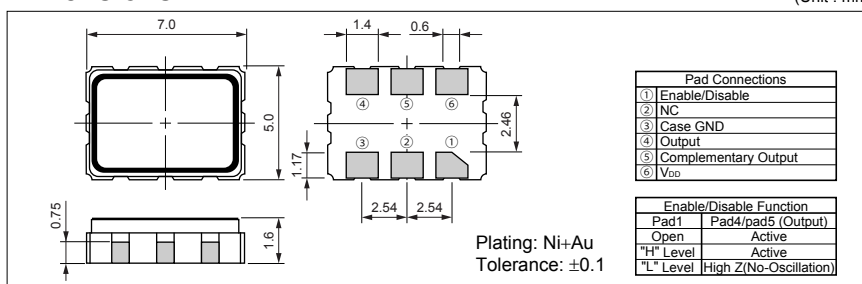

Recommended Land Pattern

(Unit : mm)

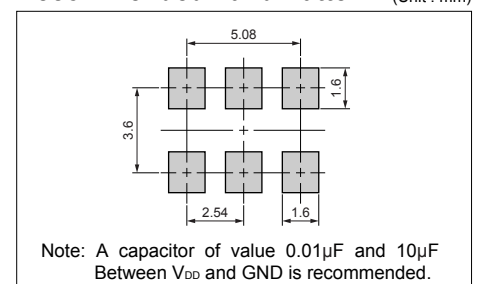

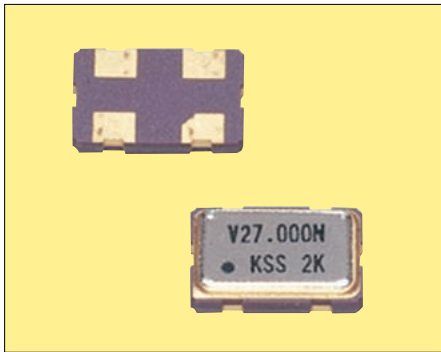

Pb Free

RoHS Compliant

Features

- Surface mount type suitable for auto pick-and-place.
- Reflow soldering compatible.
- Supply voltage $V_{DD}=3.3/5.0V$ available

Applications

- DTV, DVD

How to Order

KV5032A 27.0000 C 3 S C 00
① ② ③ ④ ⑤ ⑥ ⑦

- ① Type
- ② Output Frequency
- ③ Output Type (CMOS)
- ④ Supply Voltage 5=5.0V, 3=3.3V
- ⑤ Frequency Tolerance ($S=\pm 30 \times 10^{-6}$)
- ⑥ Symmetry/Enable Function (40/60%)
- ⑦ Customer Special Model Suffix (STD Specification is "00")

Specifications

Items	Symbol	Specifications		Units
		KV5032Axx.xxxxC5SC00 (VC-FXO-65F)	KV5032Axx.xxxxC3SC00 (VC-FXO-65FL)	
Output Frequency	F_0	8 to 40		MHz
Frequency Tolerance (Overall)	F_{tol}	± 30		$\times 10^{-6}$
Storage Temperature Range	T_{stg}	-35 to +85		$^{\circ}C$
Operating Temperature Range	T_{use}	-10 to +70		$^{\circ}C$
Max. Supply Voltage	-	7 Max.		V
Supply Voltage	V_{DD}	5 \pm 5%	3.3 \pm 5%	V
Current Consumption	I_{DD}	20 Max.	15 Max.	mA
Symmetry	SYM	40 to 60@50% V_{DD}		%
Rise / Fall Time	T_r/T_f	10 Max.	15 Max.	nS
Output Voltage-"L"	V_{OL}	0.5 Max.		V
Output Voltage-"H"	V_{OH}	90% V_{DD} Min.		V
Output Load	CL	15		pF
Start-up Time	ST	10 Max.		mS
Voltage Control Range	$\Delta f/V$	± 50 Min.	± 50 Min.	10^{-6}
Frequency Deviation	$\Delta f/V$	2.5V \pm 2.0V	1.65V \pm 1.65V	V

Note: All electrical characteristics are defined at the maximum load and operating temperature range.
Please contact us for inquiries about operating temperature range, available frequencies and other conditions.

Dimensions

(Unit : mm)

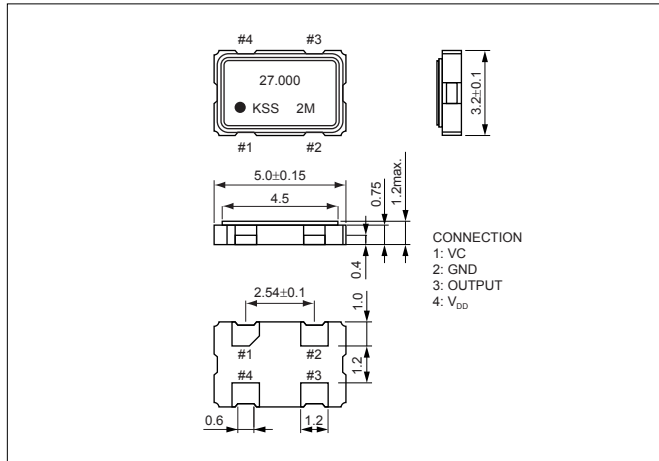

Recommended Land Pattern

(Unit : mm)

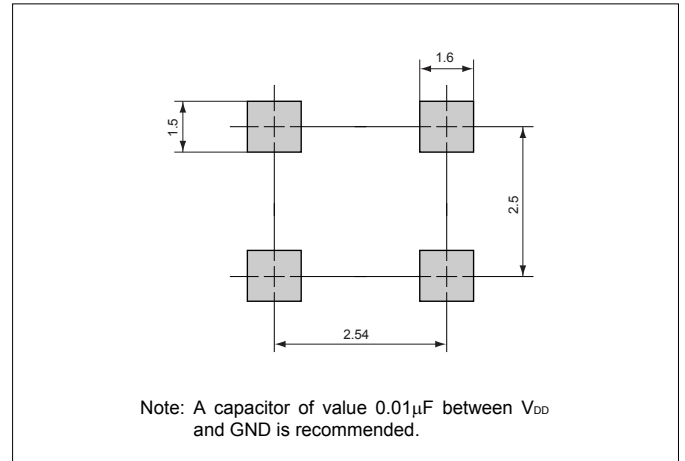

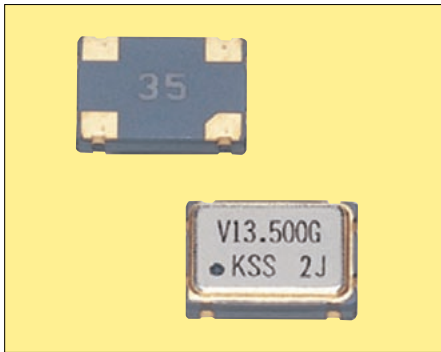

Pb Free

RoHS Compliant

Features

- Surface mount type suitable for auto pick-and-place.
- Reflow soldering compatible.
- Supply voltage $V_{DD}=3.3/5.0V$ available

Applications

- DTV, DVD

How to Order

KV7050A 27.0000 C 3 S C 00
① ② ③ ④ ⑤ ⑥ ⑦

- ① Type
- ② Output Frequency
- ③ Output Type (CMOS)
- ④ Supply Voltage 5=5.0V, 3=3.3V
- ⑤ Frequency Tolerance ($S=\pm 30 \times 10^{-6}$)
- ⑥ Symmetry/Enable Function (40/60%)
- ⑦ Customer Special Model Suffix (STD Specification is "00")

Specifications

Items	Symbol	Specifications		Units
		KV7050Axx.xxxxC5SC00 (VC-FXO-35F)	KV7050Axx.xxxxC3SC00 (VC-FXO-35FL)	
Output Frequency	F_0	8 to 40	8 to 35	MHz
Frequency Tolerance (Overall)	F_{tol}	±30		$\times 10^{-6}$
Storage Temperature Range	T_{stg}	-35 to +85		°C
Operating Temperature Range	T_{use}	-10 to +70		°C
Max. Supply Voltage	—	7 Max.		V
Supply Voltage	V_{DD}	5±5%	3.3±5%	V
Current Consumption	I_{DD}	25 Max.	20 Max.	mA
Symmetry	SYM	40 to 60@50% V_{DD}		%
Rise / Fall Time	T_r/T_f	10 Max.	15 Max.	nS
Output Voltage-"L"	V_{OL}	0.5 Max.		V
Output Voltage-"H"	V_{OH}	90% V_{DD} Min.		V
Output Load	CL	15		pF
Start-up Time	ST	10 Max.		mS
Voltage Control Range	$\Delta f/V$	±50 Min.	±50 Min.	10^{-6}
Frequency Deviation	$\Delta f/V$	2.5V±2.0V	1.65V±1.65V	V

Note: All electrical characteristics are defined at the maximum load and operating temperature range.
Please contact us for inquiries about operating temperature range, available frequencies and other conditions.

Dimensions

(Unit : mm)

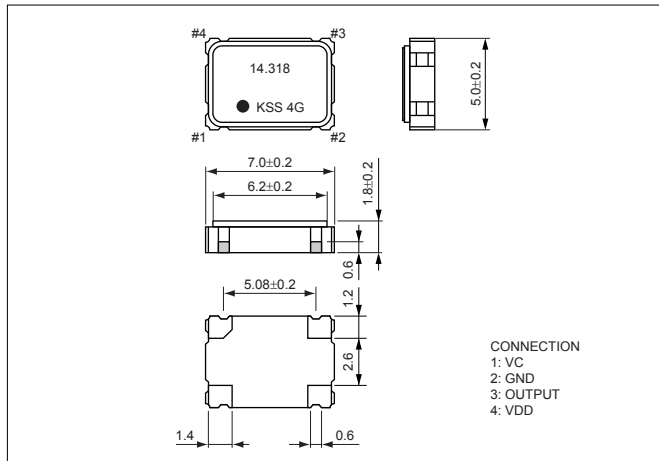

Recommended Land Pattern

(Unit : mm)

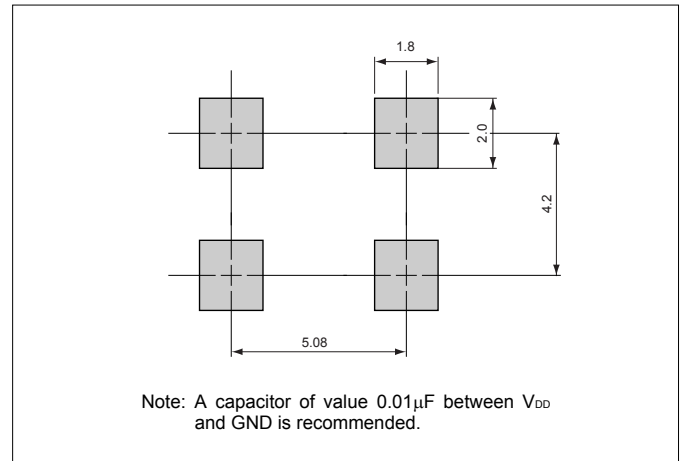



Pb Free

RoHS Compliant

Features

- "Small size", 0.063cc (5×7×1.8mm)
- Using 1 chip HCMOS IC
- 3-state devices are available
- APR (Absolute Pull Range) up to $\pm 50 \times 10^{-6}$ or $\pm 100 \times 10^{-6}$

Applications

- Digital Switching System
- ATM SDH
- SONET
- xDSL

How to Order

KV7050L 25.0000 C 3 0 A 00
① ② ③ ④ ⑤ ⑥ ⑦

- ① Type (7.0×5.0mm SMD)
- ② Output Frequency
- ③ CMOS Output
- ④ Supply Voltage: 3→3.3V, 5→5V
- ⑤ Frequency Tolerance
F→ $\pm 100 \times 10^{-6}$, G→ $\pm 50 \times 10^{-6}$
- ⑥ Enable / Symmetry 40 to 60%
- ⑦ Individual Specification

Specifications

Item	Symbol	Conditions	Specification		Units
			KV7050	KV7050L	
Output Frequency Range	F _o		7.2 to 50		MHz
Storage Temperature Range	T _{stg}		-40 to +90		°C
Operating Temperature Range	T _{use}		-40 to +85		°C
Absolute Pull Range (APR)	APR	Included 20years Aging (at +25°C)	$\pm 50/\pm 100 \times 1 (VC=0.5 \text{ to } 4.5V)$	$\pm 50/\pm 100 \times 1 (VC=0.3 \text{ to } 3.0V)$	$\times 10^{-6}$
Max. Supply Voltage	—		-0.5 to 7		V
Supply Voltage	V _{CC}		5 \pm 10%	3.3 \pm 10%	V
Current Consumption	I _{CC}		15 Max.		mA
Control Voltage	VC		2.5 \pm 2.0	1.65 \pm 1.35	V
Symmetry	SYM	50% V _{DD}	40 to 60		%
Rise Time / Fall Time	tr / tf		10 Max.		nS
Output Voltage-"L"	V _{OL}		10% V _{CC} Max.		V
Output Voltage-"H"	V _{OH}		90% V _{CC} Min.		V
Output Load	CL		15 \pm 10%		pF

*1 For 100×10^{-6} , 7.2MHz to 30MHz
• APR=Absolute Pull Range is the minimum guaranteed (voltage controlled) frequency shift ($\Delta f/f N_{ow}$)

Dimensions

(Unit : mm)

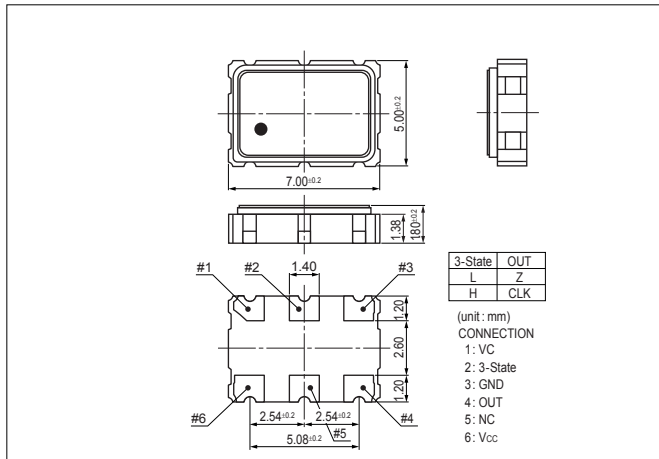

Recommended Land Pattern

(Unit : mm)

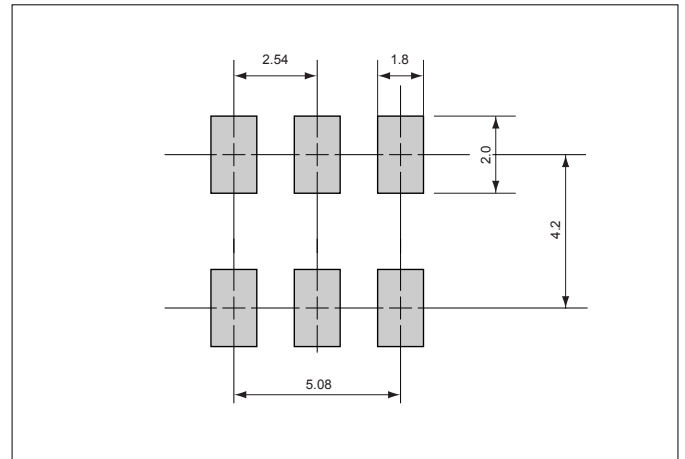



Pb Free

RoHS Compliant

Features

- Miniature ceramic package
- Highly reliable with seam welding
- LV-PECL output
- Supply voltage $V_{DD}=3.3V$
- With built-in by-pass capacitor
- Low jitter

Table 1

Freq. Tol. Code	Tol. $\times 10^{-6}$	Operating Temperature Range (°C)	Note
0	± 50	0 to +70	Standard specifications
F	± 100	-40 to +85	With only certain frequencies
G	± 50		

How to Order

KV7050W 155.520 P 3 0 D 00
① ② ③ ④ ⑤ ⑥ ⑦

- ① Type (7.0x5.0mm SMD VCXO)
- ② Output Frequency
- ③ Output Type (LV-PECL)
- ④ Supply Voltage (3.3V)
- ⑤ Frequency Tolerance (See Table 1)
- ⑥ Symmetry/ Enable Function (45/55%, Disable)
- ⑦ Customer Special Model Suffix (STD Specification is "00")

Packaging (Tape & Reel 1000pcs./reel)

Specifications

Item	Symbol	Conditions	Min.	Max.	Units	
Output Frequency Range	Fo		80	200	MHz	
Frequency Tolerance	F _{tol}	Initial tolerance, Operating temperature range, Rated power supply voltage change, Load change, Aging (1year @25°C), Shock and vibration	Op. Temp.: -40 to +85°C	-100	+100	$\times 10^{-6}$
			Op. Temp.: 0 to +70°C/ -40 to +85°C	-50	+50	
Aging	Aging	@25°C 20years	+15	-15	$\times 10^{-6}$	
Absolute Pull Range	APR		± 100	—	$\times 10^{-6}$	
Linearity	Lin		-10	+10	%	
Control Voltage	V _c		0	3.3		
Storage Temperature Range	T _{stg}		-55	+90	°C	
Operating Temperature Range	T _{use}	Standard Specifications	0	+70	°C	
		Extend (Option)	-40	+85		
Max. Supply Voltage	—		-0.5	+7	V	
Supply Voltage	V _{DD}		2.97	3.63	V	
Current Consumption	I _{DD}	50 ohm	—	70	mA	
Disable Current	I _{dis}		—	15	mA	
Symmetry	SYM	50 ohm @50% Output Swing	45	55	%	
Rise/Fall Time (20% V _{DD} to 80% V _{DD})	Tr/Tf	50 ohm	—	0.6	nS	
Output Voltage-"L"	V _{OL}	Op. Temp.: 0 to +85°C/ Typ. 1.600V	V _{DD} -1.810	V _{DD} -1.620	V	
		Op. Temp.: -40 to 0°C/ Typ. 1.605V	V _{DD} -1.830	V _{DD} -1.555		
Output Voltage-"H"	V _{OH}	Op. Temp.: 0 to +85°C/ Typ. 2.350V	V _{DD} -1.025	V _{DD} -0.880	V	
		Op. Temp.: -40 to 0°C/ Typ. 2.295V	V _{DD} -1.085	V _{DD} -0.900		
Output Load	L _{ECL}	LV-PECL	50		ohm	
Input Voltage Range	V _{IN}		0	V _{DD}	V	
Input Voltage-"L"	V _{IL}		—	30% V _{DD}	V	
Input Voltage-"H"	V _{IH}		70% V _{DD}	—	V	
Disable Time	—		—	200	nS	
Enable Time	—		—	200	nS	
Start-up Time	ST	@Minimum Operation Voltage to be 0 sec.	—	10	mS	
Phase jitter	—	12KHz to 20MHz @155.52MHz	—	1	pS	
Phase Noise @155.52MHz	—	-60(@10Hz offset) -90(@100Hz offset) -120(@1KHz offset) -140(@10KHz offset) -147(@100KHz offset) -147(@1Hz offset) -147(@10Hz offset)			dBc/Hz	

Note: All electrical characteristics are defined at the maximum load and operating temperature range.
Please contact us for inquiries about operating temperature range, available frequencies and other conditions.

Dimensions

(Unit : mm)

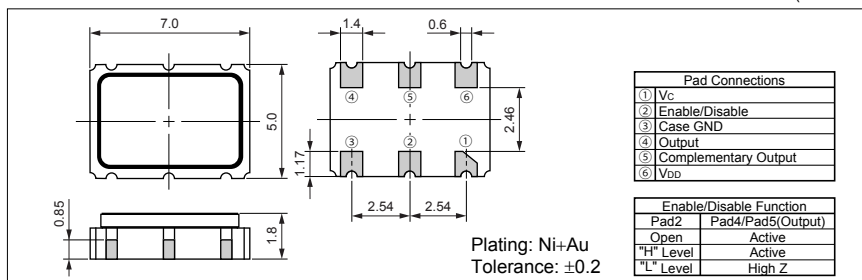

Recommended Land Pattern

(Unit : mm)

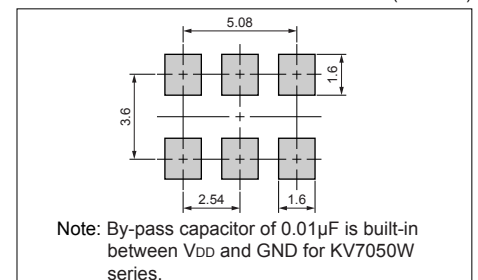

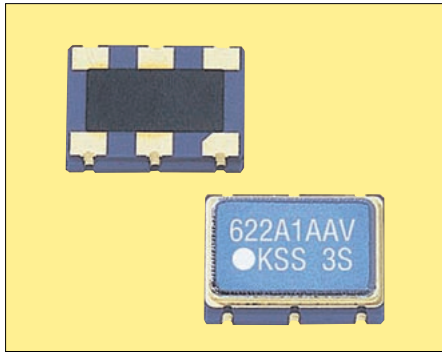

Ph Free

RoHS Compliant

Features

- Low Jitter
- Differential LV-PECL outputs
- Wide pull range $APR \pm 100 \times 10^{-6}$
- Operation at high frequency fundamental mode

Table 1

Code	APR	Operating Temperature Range (°C)	Note
	$\times 10^{-6}$		
1	± 100	-40 to +85	Standard specifications

How to Order

KV7050S 622.080 P 3 1 E 00
 ① ② ③④⑤⑥ ⑦

- ① Type (7.0×5.0mm SMD)
- ② Output Frequency
- ③ Output Type (PECL)
- ④ Supply Voltage (3.3V)
- ⑤ Frequency Tolerance (See Table 1)
- ⑥ Symmetry/Enable Function (45/55%, Stand-by)
- ⑦ Customer Special Model Suffix (STD Specification is "00")

Packaging (Tape & Reel 1000pcs./reel)

Specifications

Item	Symbol	Conditions	Min.	Max.	Units
Output Frequency Range	Fo		600	700	MHz
Absolute Pull Range	APR	Initial tolerance, Operating temperature range, Rated power supply voltage change, Load change, Aging (1year @25°C), Shock and vibration	-100	+100	$\times 10^{-6}$
Control Voltage Range	V _{CON}		0	3.3	V
Control Voltage Input Impedance	—		100 Typ.		KΩ
Transfer Slope	—		Positive		
Storage Temperature Range	T _{stg}		-55	+125	°C
Operating Temperature Range	T _{use}	Standard Specifications	-45	+85	°C
Max. Supply Voltage	—		-0.5	+5	V
Supply Voltage	V _{CC}		3.14	3.46	V
Current Consumption (Standard Loaded)	I _{CC}		—	80	mA
Symmetry	SYM		45	55	%
Rise/ Fall Time (20% V _{CC} to 80% V _{CC} Standard Loaded)	T _r /T _f		—	400	pS
Output Voltage-"L"	V _{OL}		—	1.68	V
Output Voltage-"H"	V _{OH}		2.275	—	V
Output Load (PECL)	L _{ECL}	PECL 50Ω @Terminated V _{CC} -2V	49.5	50.5	ohm
Input Voltage Range	V _{IN}		0	V _{CC}	V
Input Voltage-"L"	V _{IL}		—	30% V _{CC}	V
Input Voltage-"H"	V _{IH}		70% V _{CC}	—	V
Disable Time	—		—	200	nS
Enable Time	—		—	2	mS
Start-up Time	ST	@ Minimum Operation Voltage to be 0 sec.	—	10	mS
Phase Jitter	—	Off set Frequency: 50kHz to 80MHz	—	1	pS

Note: All electrical characteristics are defined at the maximum load and operating temperature range.
 Please contact us for inquiries about operating temperature range, available frequencies and other conditions.

Dimensions

(Unit : mm)

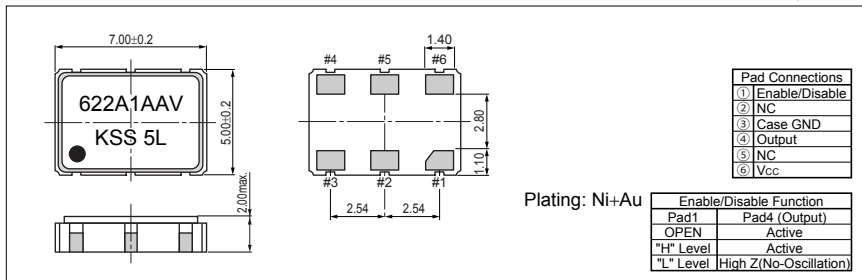

Recommended Land Pattern

(Unit : mm)

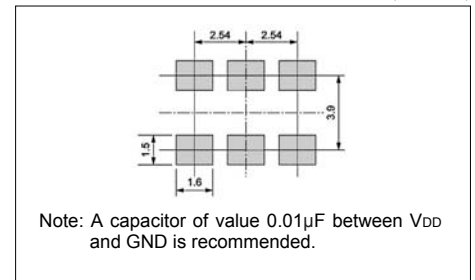



Pb Free

RoHS Compliant

Features

- Ultra-miniature SMD type (2.5x2.0x0.9mm)
- AFC function available
- Frequency stability : $\pm 2.0 \times 10^{-6} / -30$ to $+85^\circ\text{C}$
- 2.3 to 3.5V drive available
- Reflow compatible

Applications

- 3G (CDMA, W-CDMA), GPRS, GSM

How to Order

KT2520Y 26000 D C W 28 T AA
① ② ③ ④ ⑤ ⑥ ⑦ ⑧

① Series

② Output Frequency

③ Frequency Tolerance

B	$\pm 1.0 \times 10^{-6}$
C	$\pm 1.5 \times 10^{-6}$
D	$\pm 2.0 \times 10^{-6}$

④ Lower Operating Temp.

C	-30°C
E	-20°C
G	-10°C

⑤ Upper Operating Temp.

W	$+85^\circ\text{C}$
V	$+80^\circ\text{C}$
U	$+75^\circ\text{C}$

⑥ Supply Voltage

28	2.8V	30	3.0V
----	------	----	------

⑦ Voltage Control Range

TCXO	T
VCTCXO	Customer Spec

⑧ Option Code

Specifications

Item	Symbol	Conditions	Min.	Max.	Units
Output Frequency	F _o		12.6	40	MHz
Frequency Tolerance	F _{tol}	vs Temperature	-2	+2	$\times 10^{-6}$
		vs Load	-0.2	+0.2	
		vs Voltage	-0.3	+0.3	
Frequency Aging	F _{aging}	Per Year	-1	+1	$\times 10^{-6}$
Storage Temperature Range	T _{stg}		-40	+85	$^\circ\text{C}$
Operating Temperature Range	T _{use}		-30	+85	$^\circ\text{C}$
Voltage Control Range	$\Delta f/V$	Positive	± 8	± 15	$\times 10^{-6}$
Supply Voltage	V _{cc}		2.3	3.5	V
Output Level	V _{pp}	10k ohm // 10pF	0.8	—	V _{p-p}
Current Consumption	I _{DD}		—	2	mA
Symmetry	SYM	@50% V _{DD}	40	60	%
Harmonics	—		—	-5	dBc

Dimensions

(Unit : mm)

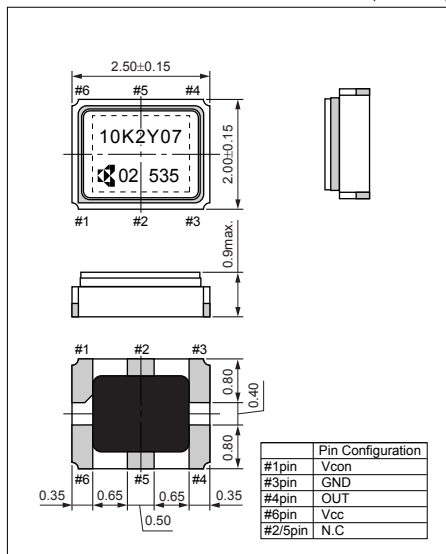

Test Circuit

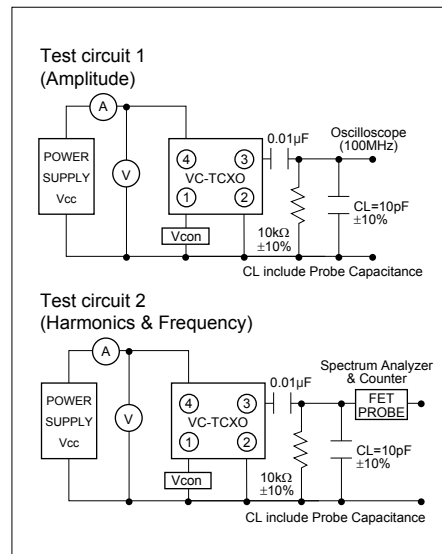

Recommended Land Pattern

(Unit : mm)

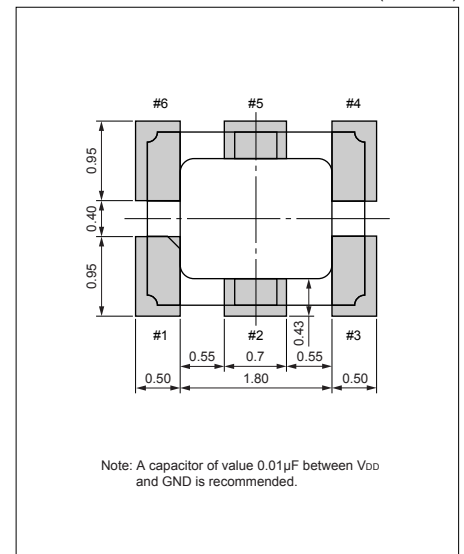



Pb Free

RoHS Compliant

Features

- Ultra-miniature SMD type (3.2x2.5x1.0mm)
- AFC function available
- Frequency stability : $\pm 0.5 \times 10^{-6} / -30$ to $+85^\circ\text{C}$
- 2.3 to 3.5V drive available
- Reflow compatible

Applications

- GPS

How to Order

KT3225F 16367 A C V 28 T AA
① ② ③ ④ ⑤ ⑥ ⑦ ⑧

① Series	A	$\pm 0.5 \times 10^{-6}$
② Output Frequency	C	-30°C
③ Frequency Tolerance	E	-20°C
④ Lower Operating Temp.	G	-10°C
⑤ Upper Operating Temp.	W	+85°C
	V	+80°C
	U	+75°C
⑥ Supply Voltage	28	2.8V
	30	3.0V
⑦ Voltage Control Range	TCXO	T
⑧ Option Code		

Specifications

Item	Symbol	Conditions	Min.	Max.	Units
Output Frequency	F _o		12.6	40	MHz
Frequency Tolerance	F _{tol}	vs Temperature	-0.5	+0.5	$\times 10^{-6}$
		vs Load	-0.2	+0.2	
		vs Voltage	-0.3	+0.3	
Frequency Aging	F _{aging}	Per Year	-1	+1	$\times 10^{-6}$
Storage Temperature Range	T _{stg}		-40	+85	°C
Operating Temperature Range	T _{use}		-30	+85	°C
Supply Voltage	V _{cc}		2.3	3.5	V
Output Level	V _{pp}	10k ohm // 10pF	0.8	—	V _{p-p}
Current Consumption	I _{DD}		—	2	mA
Symmetry	SYM	@50% V _{DD}	40	60	%
Harmonics	—		—	-5	dBc

Dimensions

(Unit : mm)

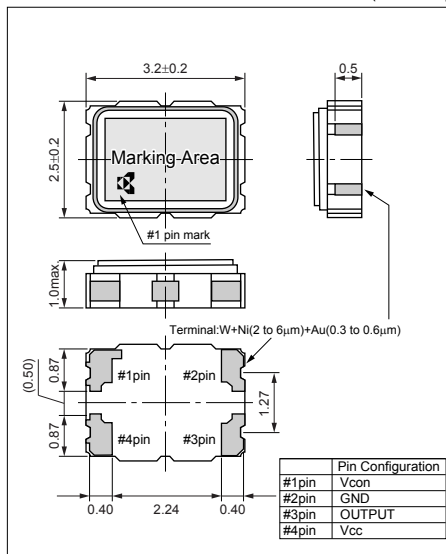

Test Circuit

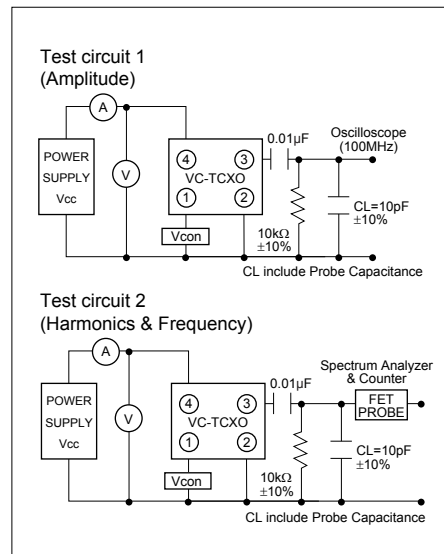

Recommended Land Pattern

(Unit : mm)

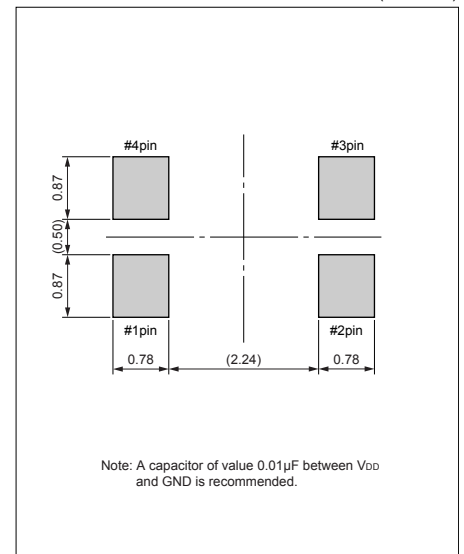



3.2x2.5mm



Pb Free

RoHS Compliant

Features

- Ultra-miniature SMD type (3.2x2.5x1.0mm)
- Reflow compatible
- AFC function available
- 2.3 to 3.5V drive available
- Frequency stability : $\pm 2.0 \times 10^{-6} / -30$ to $+85^\circ\text{C}$

Applications

- 3G (CDMA, W-CDMA)
- GPRS, GSH

How to Order

KT3225P 26000 D C W 28 T AA
① ② ③ ④ ⑤ ⑥ ⑦ ⑧

- ① Series
- ② Output Frequency
- ③ Frequency Tolerance

B	$\pm 1.0 \times 10^{-6}$
C	$\pm 1.5 \times 10^{-6}$
D	$\pm 2.0 \times 10^{-6}$

- ④ Lower Operating Temp.

C	-30°C
E	-20°C
G	-10°C

- ⑤ Upper Operating Temp.

W	$+85^\circ\text{C}$
V	$+80^\circ\text{C}$
U	$+75^\circ\text{C}$

- ⑥ Supply Voltage

28	2.8V	30	3.0V
----	------	----	------

- ⑦ Voltage Control Range

TCXO	T
VCTCXO	Customer Spec

- ⑧ Option Code

Specifications

Item	Symbol	Conditions	Min.	Max.	Units
Output Frequency	Fo		12.6	40	MHz
Frequency Tolerance	F _{tol}	vs Temperature	-2	+2	$\times 10^{-6}$
		vs Load	-0.2	+0.2	
		vs Voltage	-0.3	+0.3	
Frequency Aging	F _{aging}	Per Year	-1	+1	$\times 10^{-6}$
Storage Temperature Range	T _{stg}		-40	+85	$^\circ\text{C}$
Operating Temperature Range	T _{use}		-30	+85	$^\circ\text{C}$
Voltage Control Range	$\Delta f/V$	Positive	± 8	± 15	$\times 10^{-6}$
Supply Voltage	V _{cc}		2.3	3.5	V
Output Level	V _{pp}	10k ohm // 10pF	0.8	—	V _{p-p}
Current Consumption	I _{DD}		—	2	mA
Symmetry	SYM	@50% V _{DD}	40	60	%
Harmonics	—		—	-5	dBc

Dimensions

(Unit : mm)

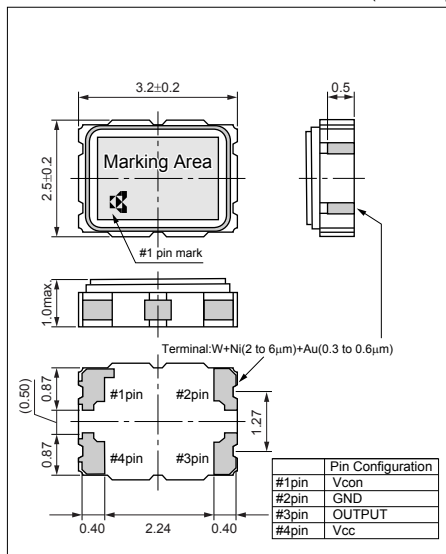

Test Circuit

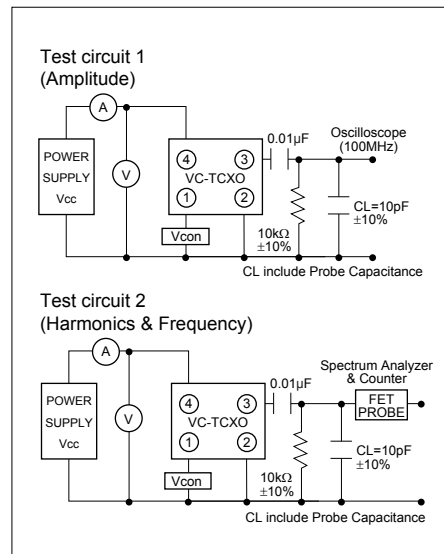

Recommended Land Pattern

(Unit : mm)

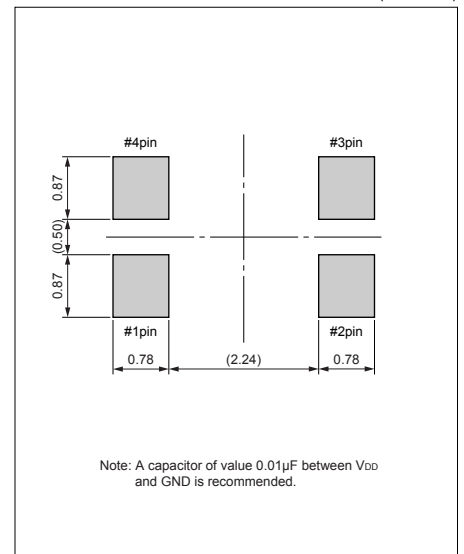

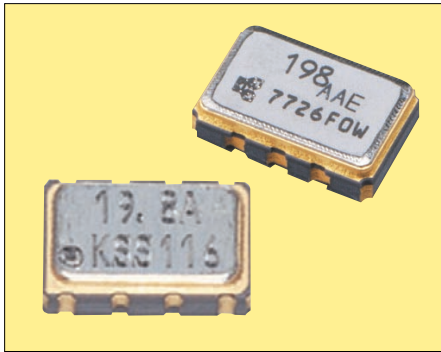

Pb Free

RoHS Compliant

Features

- Ultra-miniature SMD type (5.0x3.2x1.5mm)
- Reflow compatible
- AFC function available
- 2.3 to 5.5V drive available
- Frequency stability : $\pm 2.0 \times 10^{-6} / -30$ to $+85^\circ\text{C}$

Applications

- PDC, GSM, CDMA

How to Order

KT5032N 26000 D C W 28 T AA
① ② ③ ④ ⑤ ⑥ ⑦ ⑧

- ① Series
- ② Output Frequency
- ③ Frequency Tolerance

B	$\pm 1.0 \times 10^{-6}$
C	$\pm 1.5 \times 10^{-6}$
D	$\pm 2.0 \times 10^{-6}$

- ④ Lower Operating Temp.

C	-30°C
E	-20°C
G	-10°C

- ⑤ Upper Operating Temp.

W	$+85^\circ\text{C}$
V	$+80^\circ\text{C}$
U	$+75^\circ\text{C}$

- ⑥ Supply Voltage

28	2.8V	30	3.0V
----	------	----	------

- ⑦ Voltage Control Range

TCXO	T
VCTCXO	Customer Spec

- ⑧ Option Code

Specifications

Item	Symbol	Conditions	Min.	Max.	Units
Output Frequency	F _o		12.6	40	MHz
Frequency Tolerance	F _{tol}	vs Temperature	-2	+2	$\times 10^{-6}$
		vs Load	-0.2	+0.2	
		vs Voltage	-0.3	+0.3	
Frequency Aging	F _{aging}	Per Year	-1	+1	$\times 10^{-6}$
Storage Temperature Range	T _{stg}		-40	+85	$^\circ\text{C}$
Operating Temperature Range	T _{use}		-30	+85	$^\circ\text{C}$
Voltage Control Range	$\Delta f/V$	Positive	± 8	± 15	$\times 10^{-6}$
Supply Voltage	V _{cc}		2.3	5.5	V
Output Level	V _{pp}	10k ohm // 10pF	0.8	—	V _{p-p}
Current Consumption	I _{DD}		—	2	mA
Symmetry	SYM	@50% V _{DD}	40	60	%
Harmonics	—		—	-5	dBc

Dimensions

(Unit : mm)

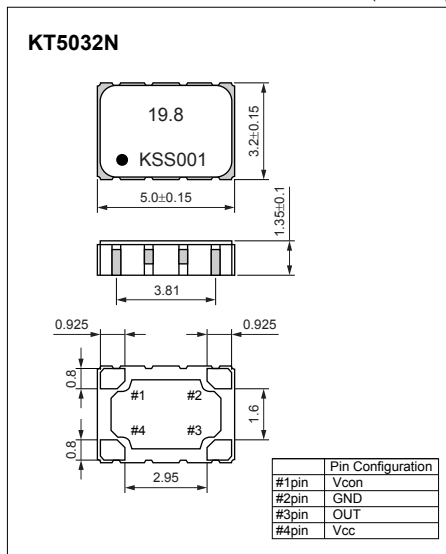

Dimensions

(Unit : mm)

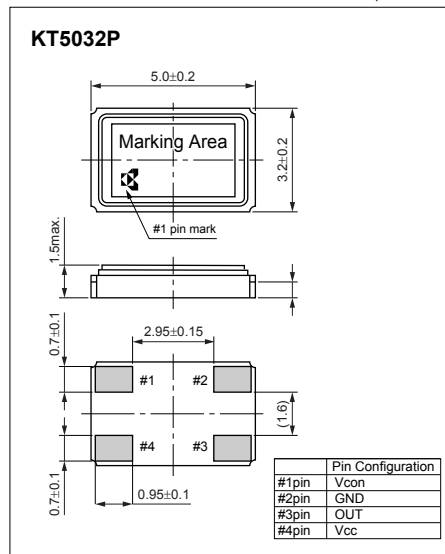

Recommended Land Pattern

(Unit : mm)

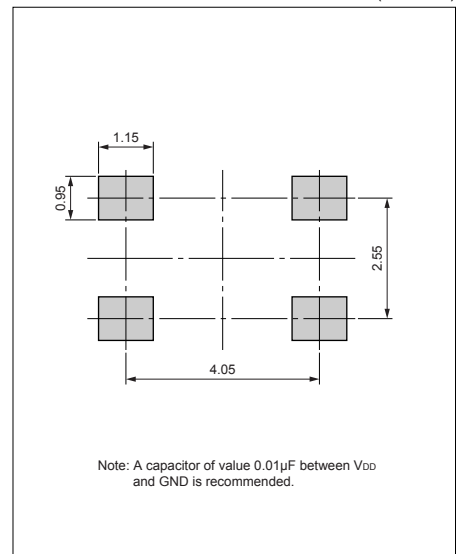



Features

- Digital processing temperature compensated crystal oscillator
- Excellent frequency temperature characteristics and frequency aging
- CMOS output

Applications

- Reference Oscillator
- PLL Oscillator

How to Order

DO 20.000000000 M 00001
 ① ② ③ ④

- ① Function
DO→DTCXO, DV→VC-DTCXO
- ② Output Frequency
- ③ Frequency Unit
M→MHz, K→kHz
- ④ Individual Specification

Specifications

Item	Symbol	Conditions	Min.	Max.	Units
Output Frequency Range	F _o		1	32	MHz
Frequency Tolerance	F _{tol}	vs Temperature DTCXO-12A/VC-DTCXO-12A : VC=Open	-0.1	+0.1	×10 ⁻⁶
		vs Voltage	-0.05	+0.05	
Storage Temperature Range	T _{stg}		-40	+85	°C
Operating Temperature Range	T _{use}		-35	+85	°C
Supply Voltage	V _{CC}		4.75	5.25	V
Current Consumption	I _{CC}		—	30	mA
Frequency Tuning Range	Δf tuning	Internal Trimmer	-0.7	0.7	×10 ⁻⁶
Frequency Aging	ΔF aging	Per Year (at +25°C)	-0.5	0.5	×10 ⁻⁶
Frequency Deviation	Δf/V	VC-DTCXO-12A Only	-2	2	×10 ⁻⁶
Control Voltage	VC	VC-DTCXO-12A Only	0.5	4.5	V
Symmetry	SYM	@50% V _{CC} 1 to 15MHz	45	55	%
		@50% V _{CC} 15 to 32MHz	30	70	
Output Voltage-"L"	V _{OL}		—	0.5	V
Output Voltage-"H"	V _{OH}		4.5	—	V
Load	CL		15	15	pF
Sub Harmonics			—	-80	dB

Note: All electrical characteristics are defined at the maximum load and operating temperature range.

Dimensions

(Unit : mm)

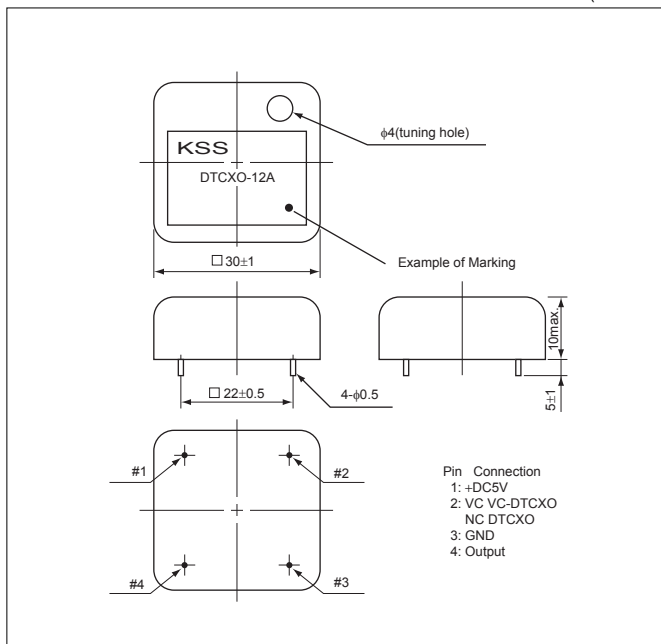



Features

- Digital processing temperature compensated crystal oscillator
- Output 50Ω
- Wide frequency range

Applications

- Reference Oscillator
- PLL Oscillator

How to Order

DO 20.000000000 M 00001
① ② ③ ④

- ① Function
DO→DTCXO, DV→VC-DTCXO
- ② Output Frequency
- ③ Frequency Unit
M→MHz, K→kHz
- ④ Individual Specification

Specifications

Item	Symbol	Conditions	Min.	Max.	Units
Output Frequency Range	F _o		30	320	MHz
Frequency Tolerance	F _{tol}	vs Temperature DTCXO-13A/VC-DTCXO-13A: VC=Open	-0.1	+0.1	×10 ⁻⁶
		vs Voltage	-0.05	+0.05	
Storage Temperature Range	T _{stg}		-40	+85	°C
Operating Temperature Range	T _{use}		-20	+70	°C
Supply Voltage	V _{CC}		4.75	5.25	V
Current Consumption	I _{CC}		—	40	mA
Frequency Tuning Range	Δf tuning	Internal Trimmer	-0.7	0.7	×10 ⁻⁶
Frequency Aging	ΔF aging	Per Year (at +25°C)	-0.5	0.5	×10 ⁻⁶
Frequency Deviation	Δf/V	VC-DTCXO-13A Only	-2	2	×10 ⁻⁶
Control Voltage	VC	VC-DTCXO-13A Only	0.5	4.5	V
Output Level	V _{pp}	50 ohm	0	—	dBm
Sub Harmonics			—	-40	dB

Note: All electrical characteristics are defined at the maximum load and operating temperature range.

Dimensions

(Unit : mm)

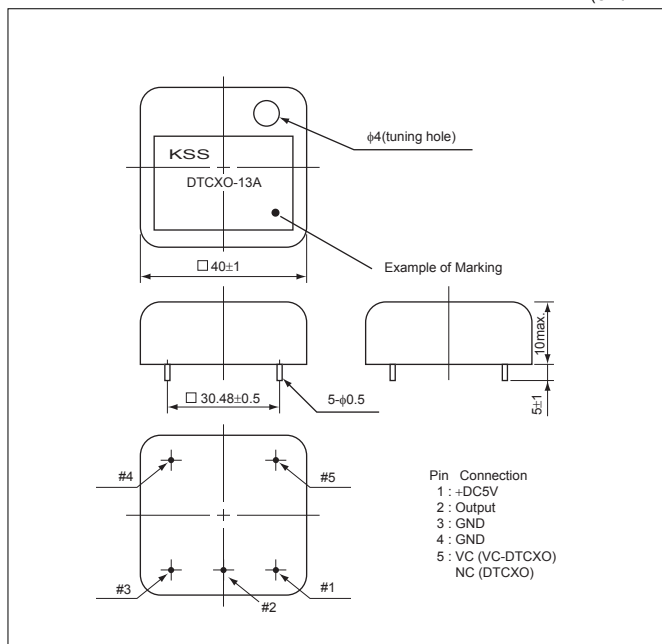

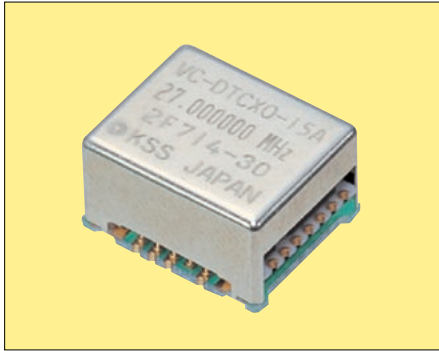

Features

- Small size (14.0×11.5×8.0mm), lead-less type (SMD)
- Supply voltage of 3.3V or 5.0V is available
- Digital processing temperature compensated crystal oscillator
- High stability ($\pm 0.5 \times 10^{-6}$ max./-30 to 80:)

Applications

- Reference Oscillator
- PLL Oscillator

How to Order

DO 20.000000000 M 00001
① ② ③ ④

- ① Function
DO→DTCXO, DV→VC-DTCXO
- ② Output Frequency
- ③ Frequency Unit
M→MHz, K→kHz
- ④ Individual Specification

Specifications

Item	Symbol	Conditions	Min.	Max.	Units
Output Frequency Range	F _o		10	40	MHz
Frequency Tolerance	F _{tol}	vs Temperature VC=Open	-0.5	+0.5	×10 ⁻⁶
		vs Voltage	-0.05	+0.05	
Storage Temperature Range	T _{stg}		-40	+85	°C
Operating Temperature Range	T _{use}		-30	+80	°C
Supply Voltage	V _{CC}		3.14	3.46	V
Current Consumption	I _{CC}		—	15	mA
Frequency Aging	ΔF aging	Per Year (at +25°C)	-0.7	0.7	×10 ⁻⁶
Frequency Deviation	Δf/V		-10	10	×10 ⁻⁶
Control Voltage	VC		0.5	2.5	V
Symmetry	SYM	50% V _{CC}	30	70	%
Output Voltage-"L"	V _{OL}		—	0.3	V
Output Voltage-"H"	V _{OH}		3	—	V
Load	CL		15	15	pF

Note: All electrical characteristics are defined at the maximum load and operating temperature range.

Dimensions

(Unit : mm)

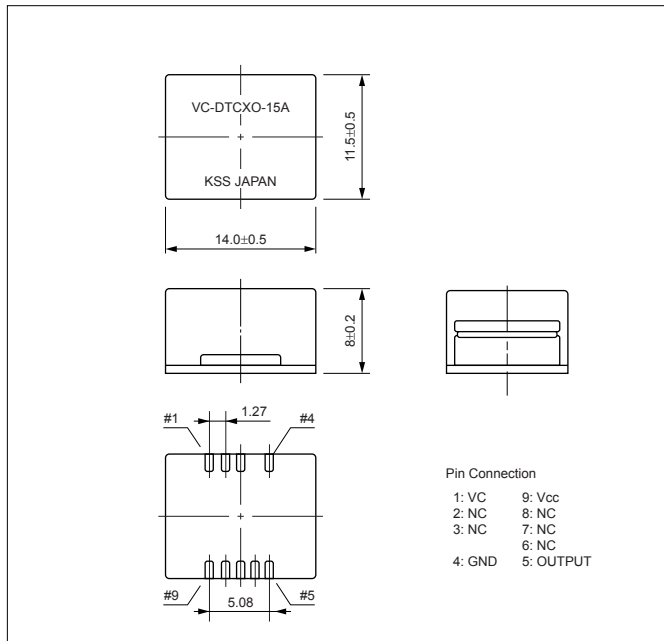

Recommended Land Pattern

(Unit : mm)

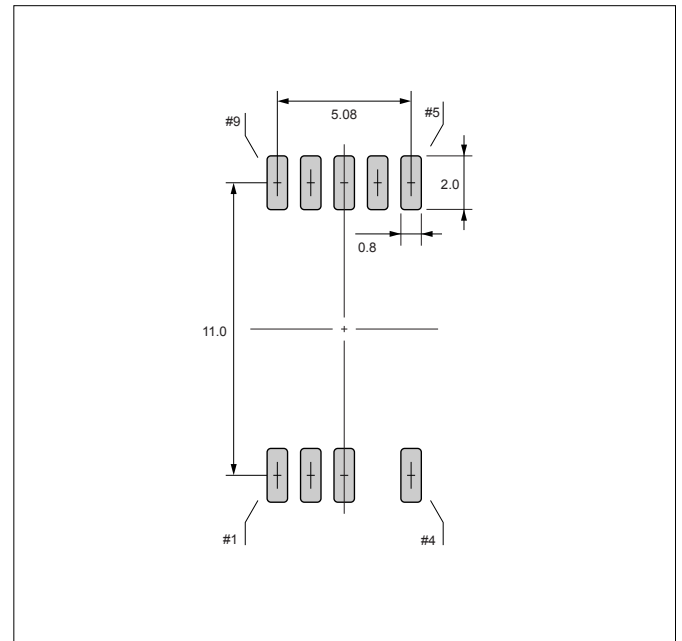



Features

- Compact OCVCXO (36.1×27.2×20.2mm)
- High stability
- Solder sealing type

Applications

- Standard Oscillator

Standard Frequencies

- 10MHz

How to Order

OV 10.00000000 M 00001
① ② ③ ④

- ①Function
OV→OCVCXO, OO→OCXO
- ②Output Frequency
- ③Frequency Unit
M→MHz
- ④Individual Specification

Specifications

Item	Symbol	Conditions	Min.	Max.	Units
Output Frequency Range	F _o		10	10	MHz
Frequency Tolerance	F _{tol}	vs Temperature	-0.03	+0.03	×10 ⁻⁶
		vs Voltage	-0.002	+0.002	
Storage Temperature Range	T _{stg}		-20	+80	°C
Operating Temperature Range	T _{use}		-10	+60	°C
Supply Voltage	V _{CC}		11.4	12.6	V
Current Consumption	I _{CC}		—	450	mA
Frequency Aging	ΔF aging	Per Year	-0.05	0.05	×10 ⁻⁶
Frequency Deviation	Δf/V		-0.5	0.5	×10 ⁻⁶
Control Voltage	V _C		0	6	V
Output Level	V _{pp}	50 ohm	3	—	dBm
Sub Harmonics			—	-20	dB

Dimensions

(Unit : mm)

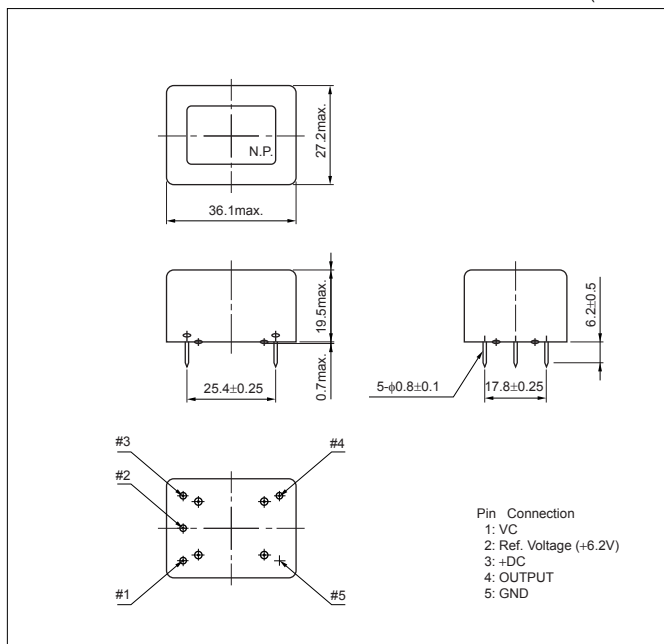



Features

- Frequency control function by GPS
- Highly stable and accurate reference frequency by Rb atom oscillator
- Superior long term stability
- 10MHz-8 output standard
- DC/AC power supply automatic changeover (built-in back-up battery)

Applications

- Digital TV Broadcasting Station and Transmitter
- Accurate Frequency Reference Oscillator for Laboratory and Factory
- Base Station for Stratum1

How to Order

MO 10.000000000 M 00001
 ① ② ③ ④

- ① Function
MO→MCXO
- ② Output Frequency
- ③ Frequency Unit
M→MHz
- ④ Individual Specification

Specifications

Item	Symbol	Conditions	Min.	Max.	Units
Output Frequency Range	F _{OUT}	8 Output	10	10	MHz
Frequency Stability	F _{SBY}	GPS Locked / The Temperature Slope is Less than 10 C/hour	-3	3	×10 ⁻¹¹
Operable Temperature Range	T _{stg}		-20	+60	°C
Operating Temperature Range	T _{OPR}		-10	+45	°C
Supply Voltage (AC)	V _{CC}		90	110	V
			180	220	
Supply Voltage ADC			22.8	25.2	V
Power Consumption (Warm-up Condition)		DC +25°C	—	100	W
Power Consumption (Normal Condition)		DC +25°C	—	50	W
Frequency Aging	Δf aging	Per Year (GPS Locked ±2×10 ⁻¹² /24h Average)	-5	5	×10 ⁻¹⁰
Output Level	V _{out}	50 ohm	0	3	dBm

Dimensions

(Unit : mm)

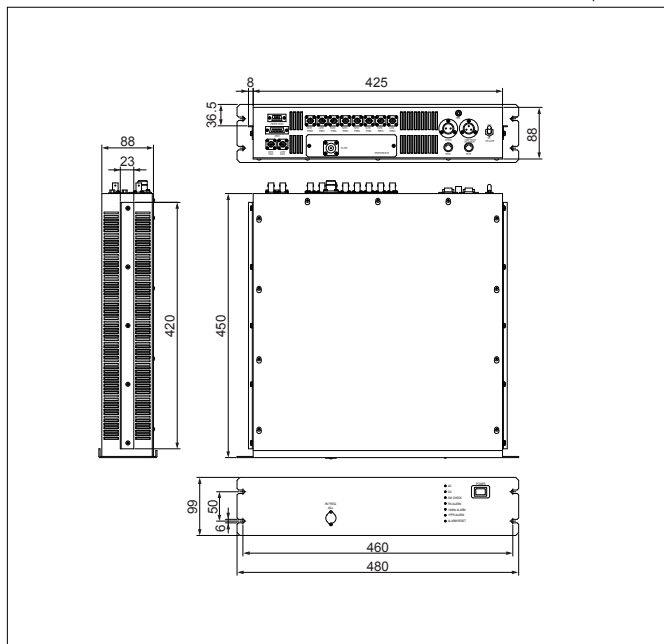



1. Shock & Drop • Vibration

Do not inflict excessive shock and mechanical vibration that exceeds the norm, such as hitting or mistakenly dropping, when transporting and mounting on a board. There are cases when pieces of crystal break, and pieces that are used become damaged, and become inoperable. When a shock or vibration that exceeds the norm has been inflicted, make sure to check the characteristics.

2. Cleaning

Since a crystal piece can be broken by resonance when a crystal device is cleaned by ultrasonic cleaning. Be careful when carrying out ultrasonic cleaning.

3. Soldering conditions

To maintain the product reliability, please follow recommended conditions.

Standard soldering iron conditions

Crystal Oscillators	
Soldering iron	280°C to 340°C
Time	3+1-0sec. max.

Reflow conditions (Example)

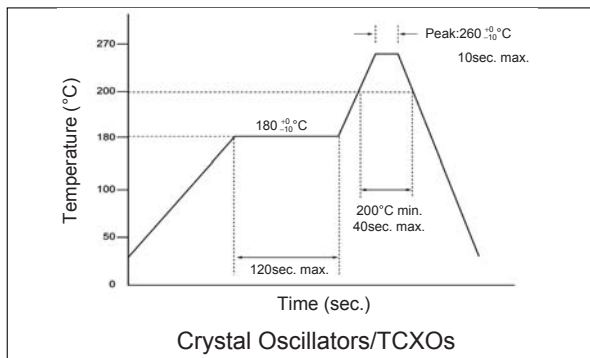

Recommended reflow Conditions vary depending upon products. Please check with the respective specification for details.

4. Mounting Precautions

Leaded Devices

The special glass, located where the lead of the retainer base comes out, is aligned with the coefficient of thermal expansion of the lead, if the glass is damaged and cracks appear, there may be cases in which performance deteriorates and it fails to operate.

Consequently, when making the device adhere closely and applying solder, align the gap of the hole of the board with the gap of the lead and insert without excessive force.

When making the device adhere closely to a through hole board and applying solder, be careful that the solder does not get into the metal part of the retainer base and cause a short. Putting in an insulation spacer is one more method of preventing a short circuit.

When the lead is mounted floating, fix it as far as possible so that contact with other parts and the breakage due to the fatigue, and the mechanical resonance of the lead will not occur.

When the lead is bent and used, do not bend the lead directly from the base, separate it 0.5mm or more and then bend it. When bending, before attaching to the board, fix the place where the lead comes out in advance and attach it after bending so that a crack does not occur in the glass part.

Surface Mount Devices

The lead of the device and the pattern of the board is soldered on the surface. Since extreme deformation of the board tears off the pattern, tears off the lead metal, cracks the solder and damages the sealed part of the device and there are cases in which performance deteriorates and operation fails, use it within the stipulated bending conditions. Due to the small cracks in the board resulting from mounting, please pay sufficient attention when attaching a device at the position where the warping of the board is great.

When using an automatic loading machine, as far as possible, select a type that has a small impact and use it while confirming that there is no damage.

Surface mount devices are NOT flow soldering compatible.

5. Storage Condition

Since the long hour high temperature and low temperature storage, as well as the storage at high humidity are causes of deterioration in frequency accuracy and solderability.

Parts should be stored in temperature range of -5 to +40°C, humidity 40 to 60% RH, and avoid direct sunlight. Then use within 6 months.



6. In order to use crystal oscillators

- (1) The miniatre crystal oscillator for the clock utilizes a CMOS IC and incorporates a protective circuit against static electricity. However, exercise care in the same manner as for a normal CMOS IC.
- (2) Internal capacitor is not provided in the power supply section (+DC–GND). *
To serve as overimpressed voltage and overcurrent protective device, place a bypass capacitor (0.01μF) as near as possible to the (+DC–GND) terminal. However, the capacitance value is meant as a guideline. Depending on the capacitor type, frequency characteristics vary. Accordingly, use a capacitor that matches the frequency characteristics.
* KC7050H (K50H) / KC7050S (FSO) series has Bypass Capacitor between V_{DD} and GND.
- (3) Applying reverse voltage could result in damage to internal parts. Take care not to connect terminals incorrectly.
- (4) Please do not use oscillators under unfavorable condition such as beyond specified range in catalog or specification sheet.
- (5) Please keep oscillators away from water, salt water or harmful gas.
- (6) KC7050H (K50H) / KC7050S (FSO) series should be stored in humidity-controlled area after the package is unsealed, in temperature +25±5°C, under humidity of 65%RH, and should be mounted on PCB within 7 days.

Clock Timing Chart

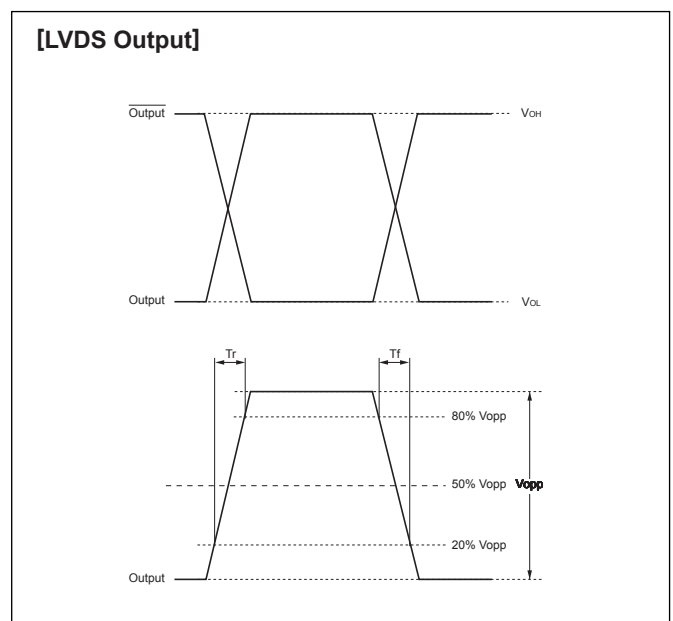
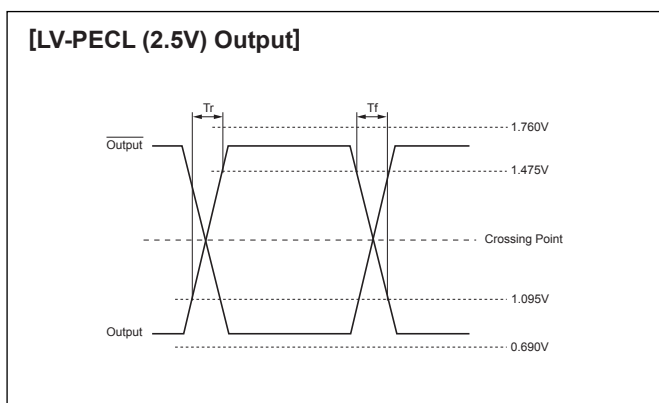
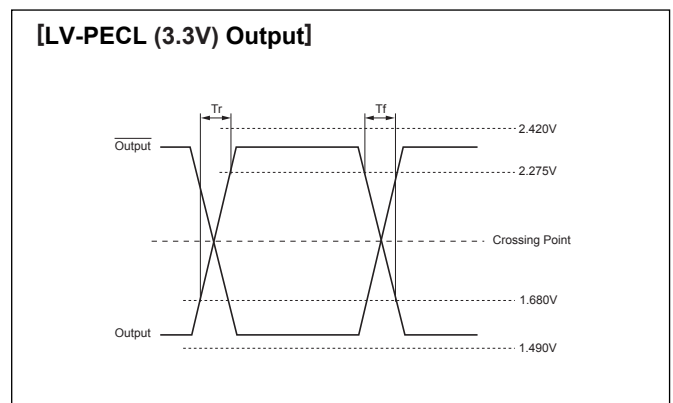
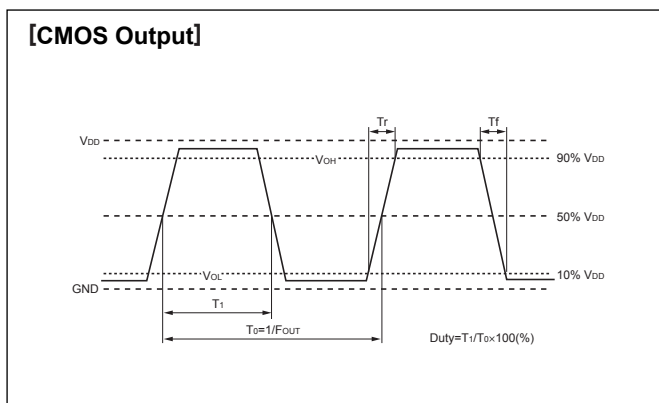

Test Circuits

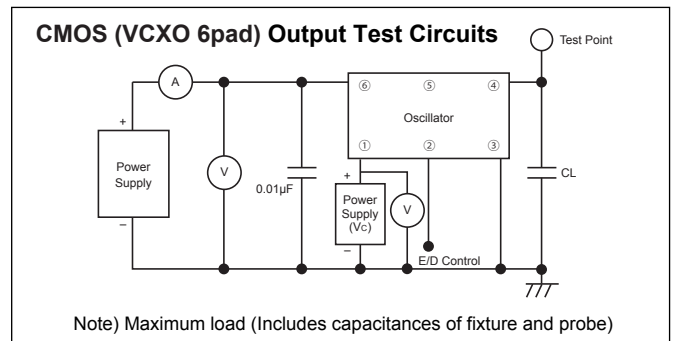
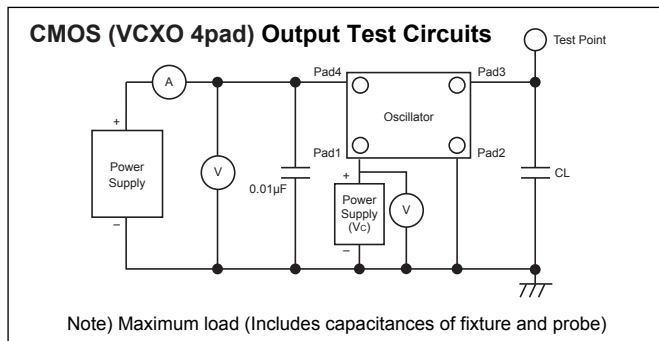
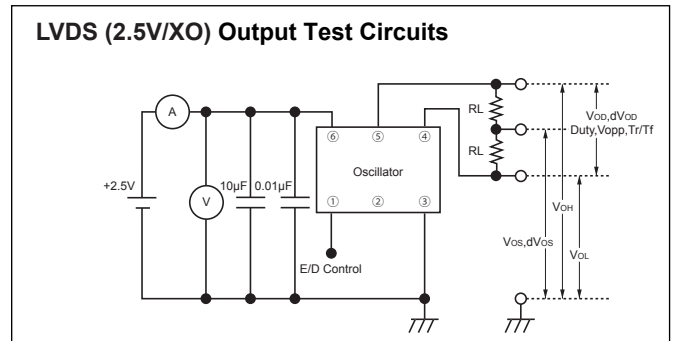
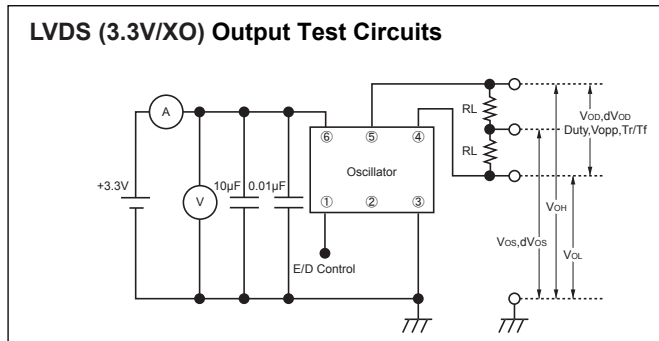
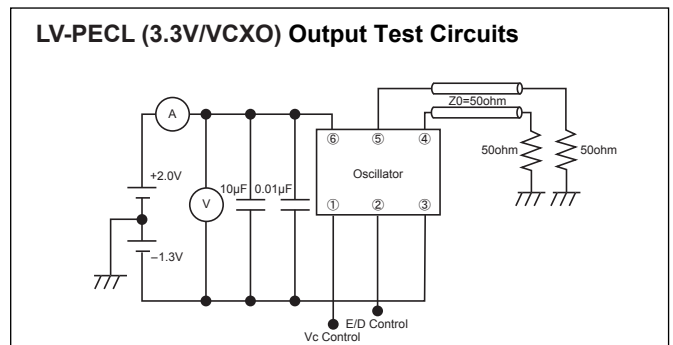
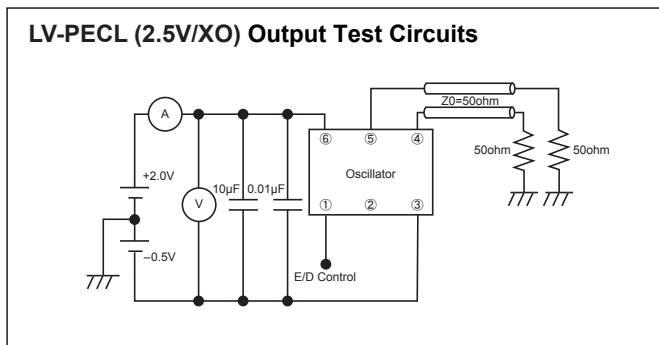
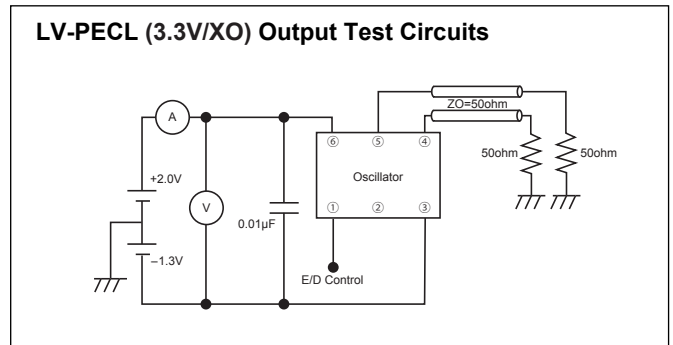
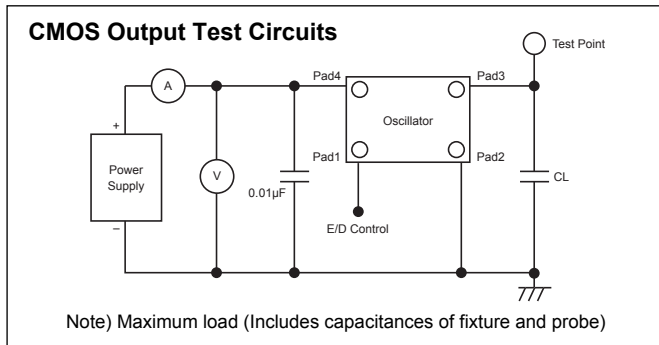

Tape & Reel Specifications

Crystal Oscillators

	KC2520A	KC3225A	
T A P E	A	2.0±0.05	2.0±0.05
	B	4.0±0.1	4.0±0.1
	C	φ1.5+0.1/-0	φ1.5+0.1/-0
	D	4.0±0.1	4.0±0.1
	E	3.5±0.05	3.5±0.05
	F	1.75±0.1	1.75±0.1
	G	8.0±0.2	8.0±0.2
	H	φ1.1±0.1	φ1.5+0.1/0
	J	2.7±0.1	3.5±0.05
	L	2.2±0.1	2.8±0.05
	N	1.0±0.1	1.1±0.05
O	0.2±0.05	0.25±0.05	
R E E L	P	φ180+0/-3	φ180+0/-3
	Q	φ60+1/-0	φ60+1/-0
	R	φ13±0.2	φ13±0.2
	S	φ21±0.8	φ21±0.8
	U	2.0±0.5	2.0±0.5
	W	9.0+0.3/-0	9.0±0.3
Qty	2000	2000	

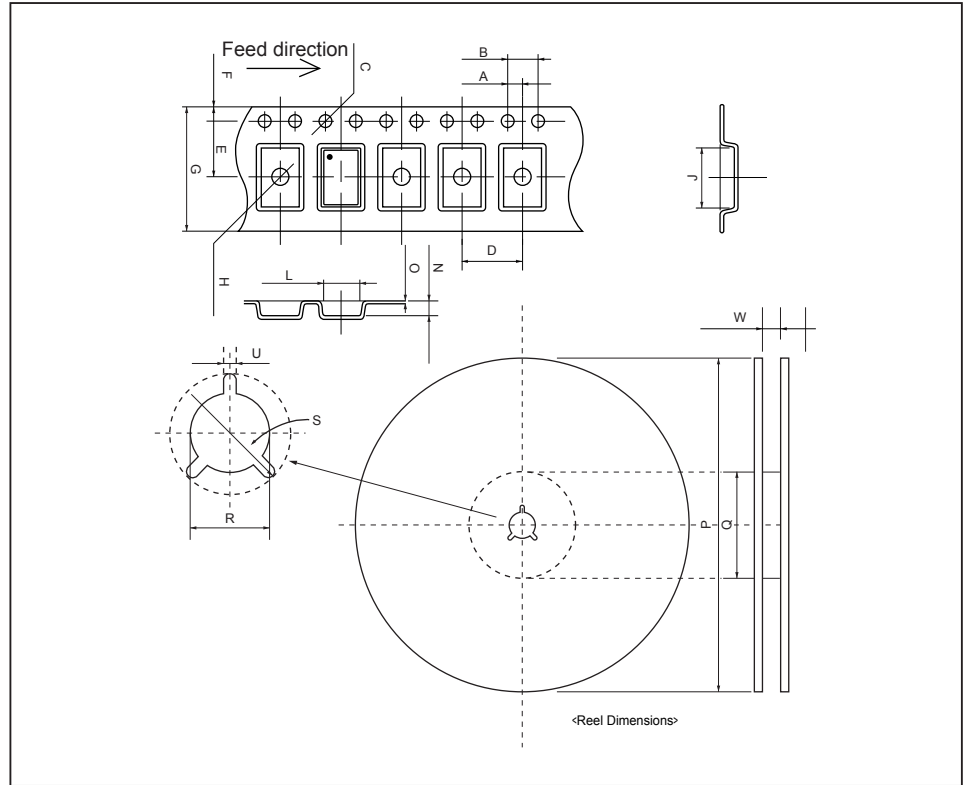

	KC5032A KC5032P	KC5032D KV5032A	KC7050S KV7050S	KC7050B KV7050A KV7050L	KC7050A KC7050C KC7050H KC7050P KC7050W	KT3225	KC5032H	KT2520Y	KT5032	
T A P E	A	1.5+0.1/-0	2.0±0.1	2.0±0.1	2.0±0.1	2.0±0.1	2.0±0.05	2.0±0.1	2.0±0.05	2.0±0.1
	B	4.0±0.1	4.0±0.1	4.0±0.1	4.0±0.1	4.0±0.1	4.0±0.1	4.0±0.1	4.0±0.1	4.0±0.1
	C	φ1.5+0.1/-0	φ1.55±0.1	φ1.55±0.1	φ1.55±0.1	φ1.5±0.1	φ1.5+0.1/-0	φ1.5+0.1/-0	φ1.5+0.1/-0	φ1.5+0.1/-0
	D	8.0±0.1	8.0±0.1	8.0±0.1	8.0±0.1	8.0±0.1	4.0±0.1	8.0±0.1	4.0±0.1	8.0±0.1
	E	5.5±0.05	5.5±0.1	7.5±0.1	7.5±0.1	7.5±0.1	3.5±0.05	5.5±0.1	3.5±0.05	5.5±0.1
	F	1.75±0.1	1.75±0.1	1.75±0.1	1.75±0.1	1.75±0.1	1.75±0.1	1.75±0.1	1.75±0.1	1.75±0.1
	G	12.0±0.3	12.0±0.3	16.0±0.3	16.0±0.3	16.0±0.2	8.0±0.3	12.0±0.3	8.0±0.2	12.0±0.3
	H	φ1.5+0.1/0	φ1.55±0.1	φ1.55	φ1.55	φ1.55±0.1	φ1.5+0.1/-0	φ1.5+0.1/-0	φ1.1±0.1	φ1.5+0.1/-0
	J	5.5±0.1	5.4±0.1	8.18	8.18	7.4±0.1	3.5±0.1	5.5±0.1	2.7±0.1	5.5±0.1
	L	3.7±0.1	3.6±0.1	5.56	5.56	5.4±0.1	2.8±0.1	3.7±0.1	2.2±0.1	3.7±0.1
	N	1.4±0.1	1.7±0.1	2.16±0.1	2.16±0.1	2.0±0.1	1.1±0.1	1.6±0.1	1.0±0.1	1.6±0.1
O	0.3±0.05	0.3±0.05	0.3±0.05	0.3±0.05	0.3±0.05	0.25±0.05	0.3±0.05	0.2±0.05	0.3±0.05	
R E E L	P	φ180+0/-3	φ254±2	φ330±2/φ254±2	φ254±2	φ180+0/-3	φ180±2	φ330±1	φ180+0/-1.5	φ330±1
	Q	φ60+1/-0	φ100±1	φ100±1	φ100±1	φ60+1/-0	φ60+1/-0	φ100±1/φ60	φ60+1/-0	φ100±1
	R	φ13±0.2	φ13±0.5	φ13±0.3	φ13±0.3	φ13±0.2	φ13±0.2	φ13±0.2	φ13±0.2	φ13±0.2
	S	φ21±0.8	φ21±0.8	φ21±0.8	φ21±0.8	φ21±0.8	φ21±0.8	φ21±0.8	φ21±0.8	φ21±0.8
	U	2.0±0.5	2.0±0.5	2.0±0.5	2.0±0.5	2.0±0.5	2.0±0.5	2.0±0.5	2.0±0.5	2.0±0.5
	W	13.0±0.3	13.4+2/-0	16.4	17.5±0.5/16.4	17±0.2	9.0±0.1	13.5±1	9.0+0.3/-0	13.5±1
Qty	1000	1000	3000/1000	1000	1000	2000	4000/2000	2000	4000/2000	

THE NEW VALUE FRONTIER



Crystal Applied Products

Synthetic Quartz Crystals
Crystal Blanks
Optical Devices



1. Quartz Crystals... What?

The quartz crystal is a single crystal of silicon dioxide and used in important electronic components of digital equipment such as mobile communications, optic communications, video equipment and PCs as a precise source of electrical signal.

2. Quartz Crystals... Why?

The quartz crystal has a character when the compression is applied to the direction of the crystal axis (x axis), the electric change) generates on the quartz crystal plate, and on the contrary, when the electricity is applied to the quartz crystal plate, the distortion occurs inside the crystal plate. The phenomenon is called the piezo electric effect or piezo electric reverse effect.

3. Synthetic Quartz Crystals... How?

The synthetic quartz crystal is grown by the hydrothermal method using the pressured container called the autoclave. The crystal is insoluble to most of the solution under the normal temperature and pressure but becomes soluble by the hydrothermal reaction in the high temperature and high pressure. The growth of the synthetic quartz crystal is taking advantage of this reaction. The high pressure necessary for growing is obtained by filling the alkaline solution up to the approximate 70-85% of the capacity of the autoclave and applying the temperature. The ordinary growing temperature is approximately 350-360°C and the growing pressure is approximately 90-145Mpa.

The autoclave, upper growing area and lower dissolution area is partitioned by the perforated panel called the baffle. Hang the seed crystal in the upper growing area and place the raw material, Lasca, a fragment of the natural quartz crystal in the lower dissolution area. By maintaining the temperature in the growing area lower than the solution area, the raw material in a saturated state in the dissolution area will rise to the growing area by the heat convection provided by the temperature difference. Since the growing area is lower than the dissolution area in temperature, the solution will become a super-saturation and re-crystallize the surface of the seed crystal.

The growing speed is approximately 0.4-0.6mm per day and the growing number of day is from about 40 days to more than 200 days depending on the applications. With the strict temperature and pressure control for a long period of time, you will get approximately 1,500-2,000kg of high quality synthetic quartz crystals in one growth process.

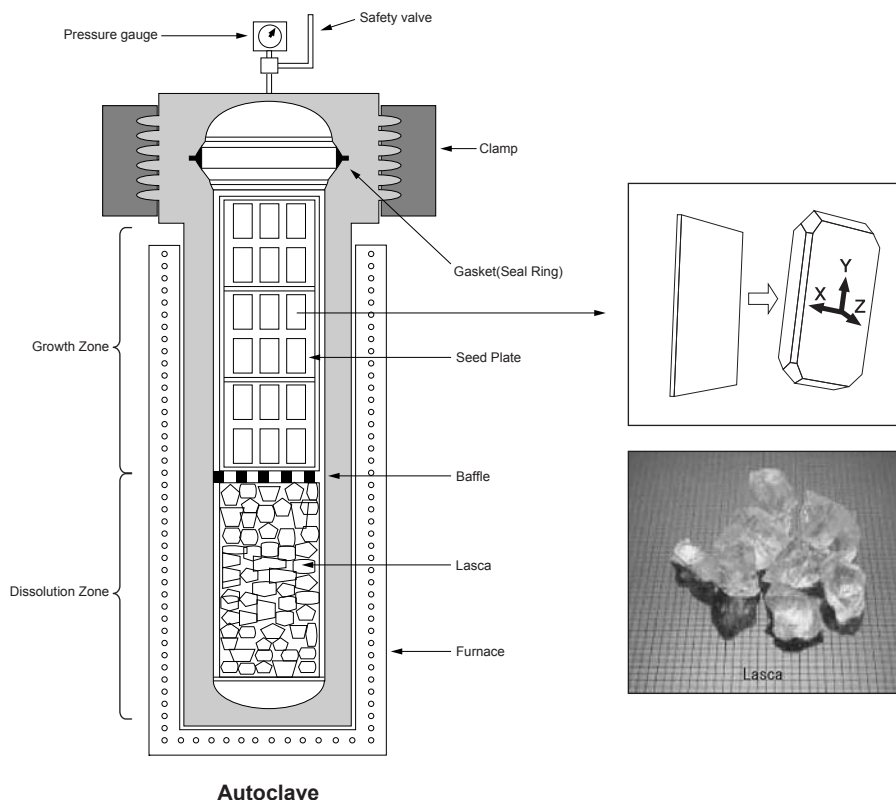

Lumbered P-bar

Type	Orientation (ϕ)	Dimensions (mm)			Weight (g)
		X \pm 0.2	Z \pm 0.2	Y \pm 5	
LP0918MS	0°	9.0	18.0	200	85
LP1020MS	0°	10.0	20.0	200	105

Lumbered Z-bar

Type	Orientation (ϕ)	Dimensions (mm)			Weight (g)
		X \pm 0.2	Z \pm 0.2	Y \pm 5	
LZ3118MS	0°	31.0	18.0	210	303
LZ3119MS	0°	31.0	19.0	210	319
LZ3120MS	0°	31.0	20.0	210	336
LZ3122MS	0°	31.0	22.0	210	369
LZ6518MS	0°	65.0	18.0	210	602
LZ6519MS	0°	65.0	19.0	210	636
LZ6520MS	0°	65.0	20.0	210	670
LZ6522MS	0°	65.0	22.0	210	738
LZ6532MS	0°	65.0	32.0	200	950
LZ6534MS	0°	65.0	34.0	200	1079
LZ6538MS	0°	65.0	38.0	200	1160
LZ6540MS	0°	65.0	40.0	200	1220

Dimensions

(Unit : mm)

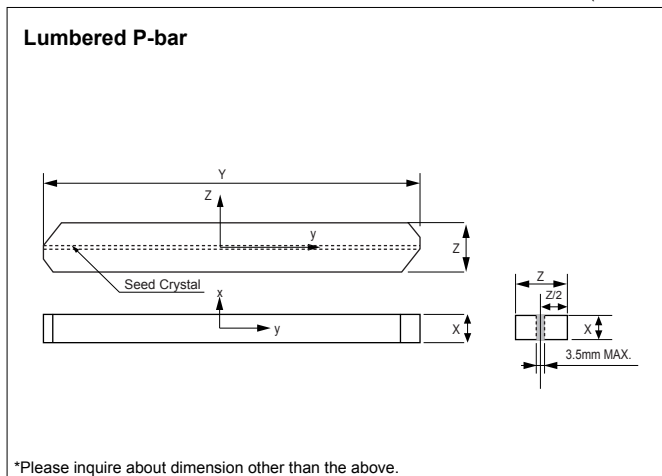

Dimensions

(Unit : mm)

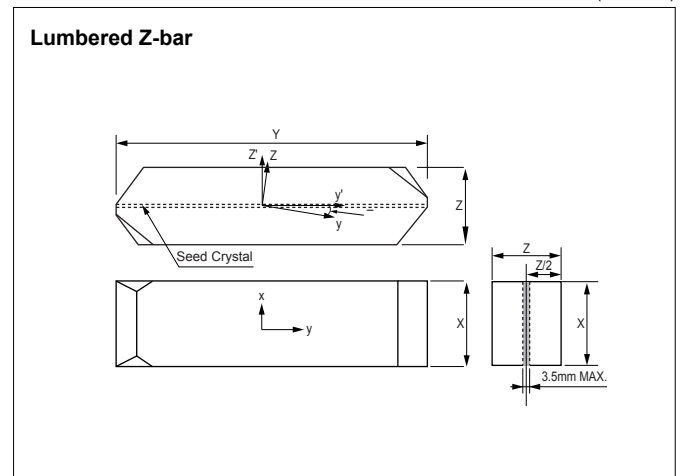

Specifications

- Kind of crystal : Right hand crystal unless otherwise specified.
- Twinning : No electrical or optical twinning is included.

Infra-red quality indication α (3500cm^{-1})

Grades	α Maxima
Aa	0.026
A	0.033
B	0.045
C	0.060
D	0.080
E	0.120

Inclusion density

Grades	Inclusion density (/cm ³)			
	10-30(μm)	30-70(μm)	70-100(μm)	>100(μm)
I a	2	1	0	0
II b	3	2	1	1
I	6	4	2	2
II	9	5	4	3
III	12	8	6	4

Etch channel density ρ

Grades	Etch channel density ρ (/cm ²)
1	10
2	30
3	100
4	300
5	600

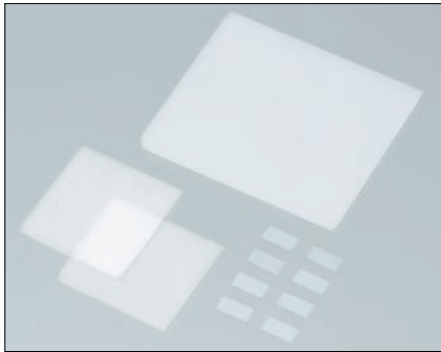

Features

- Manufactures blanks for fine and miniature crystal units.

Applications

- Blanks for crystal units.

Wafers for blanks

(Unit : mm)

Model	Basic Frequency	Dimensions	Thickness	Surface Finish	Main Face Angle
1" Rectangular plate	—	25.4×25.4	0.045MIN	#4000	Angle Specified±15"
2" Rectangular plate	—	50.8×50.8	0.085MIN	#4000	Angle Specified±15"
3" Rectangular plate	—	76.2×76.2	0.200MIN	#4000	Angle Specified±60"

Blanks

(Unit : mm)

Model	Basic Frequency	Dimensions	Surface Finish	Main Face Angle	Contour Finish
L2.0 Blank	12MHz ~ 55MHz	Long Side 2.0	#4000	Angle Specified±15"	#4000
L3.5 Blank	10MHz ~ 55MHz	Long Side 3.5	#4000	Angle Specified±15"	#4000

*Size and thickness other than above shall be studied upon request

Cut Angle of Crystal Blank

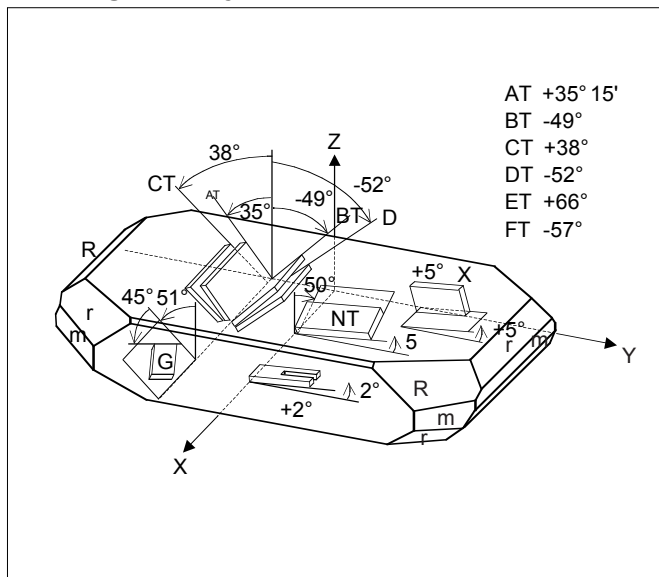

AT Cut Plate

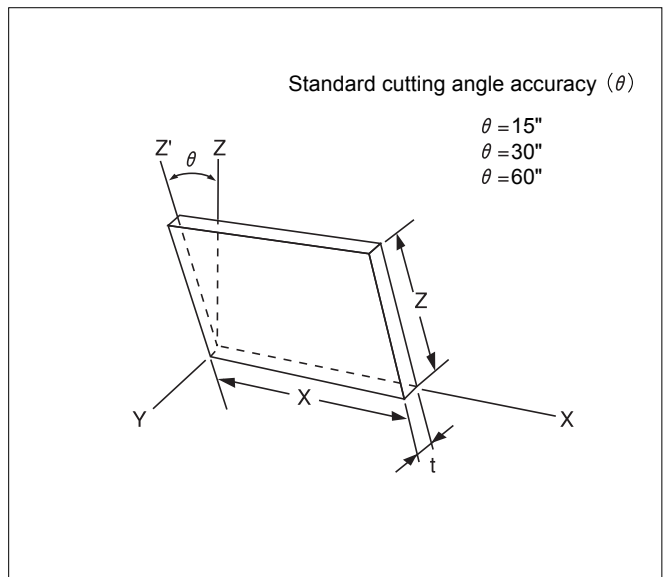

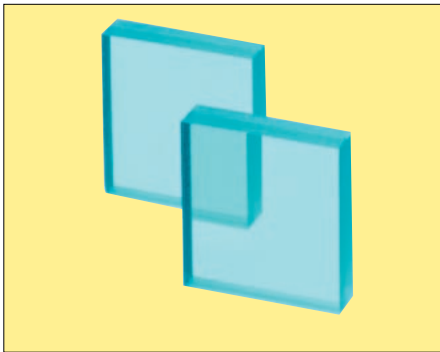

Features

- Made of high quality synthetic quartz crystal for optical device.
- Available for requirement of various spectrum by infrared absorption glass or infrared-cut coating.
- Available with ultra violet cut coating or ultra violet-cut coating + infrared cut coating
- Available with large size aperture used for single lens reflex digital still camera.
- Flexible design depending on each separation pattern.

Applications

- Digital video camera.
- Security camera.
- Digital still camera.

Dimensions

(Unit : mm)

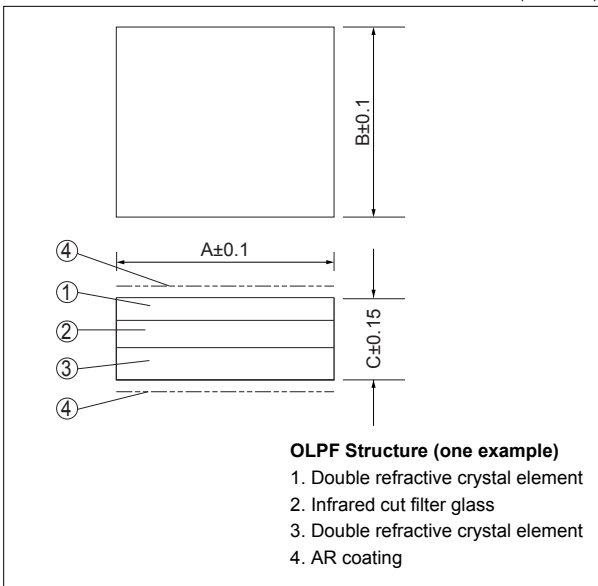

Specifications

Item	Specification
Outline dimensions	5~30mmφ
Separation direction	On discussion
Optic axis tolerance	±60' MAX.
Flatness	Within 5 Newton rings
Defect limit	30μm MAX.
Composition	1~7pieces
Transmittance	On discussion

* Please consult us if you require about specification other than above.

Standard Dimensions

	1/2 inch size	1/3 inch size	1/4 inch size	1/5 inch size
A	12mm	8.8mm	7.8mm	5.5mm
B	11mm	8.2mm	7.3mm	5.0mm
C	Determined in accordance with CCD image sensor			

Spectral Transmittance Characteristics (Example)

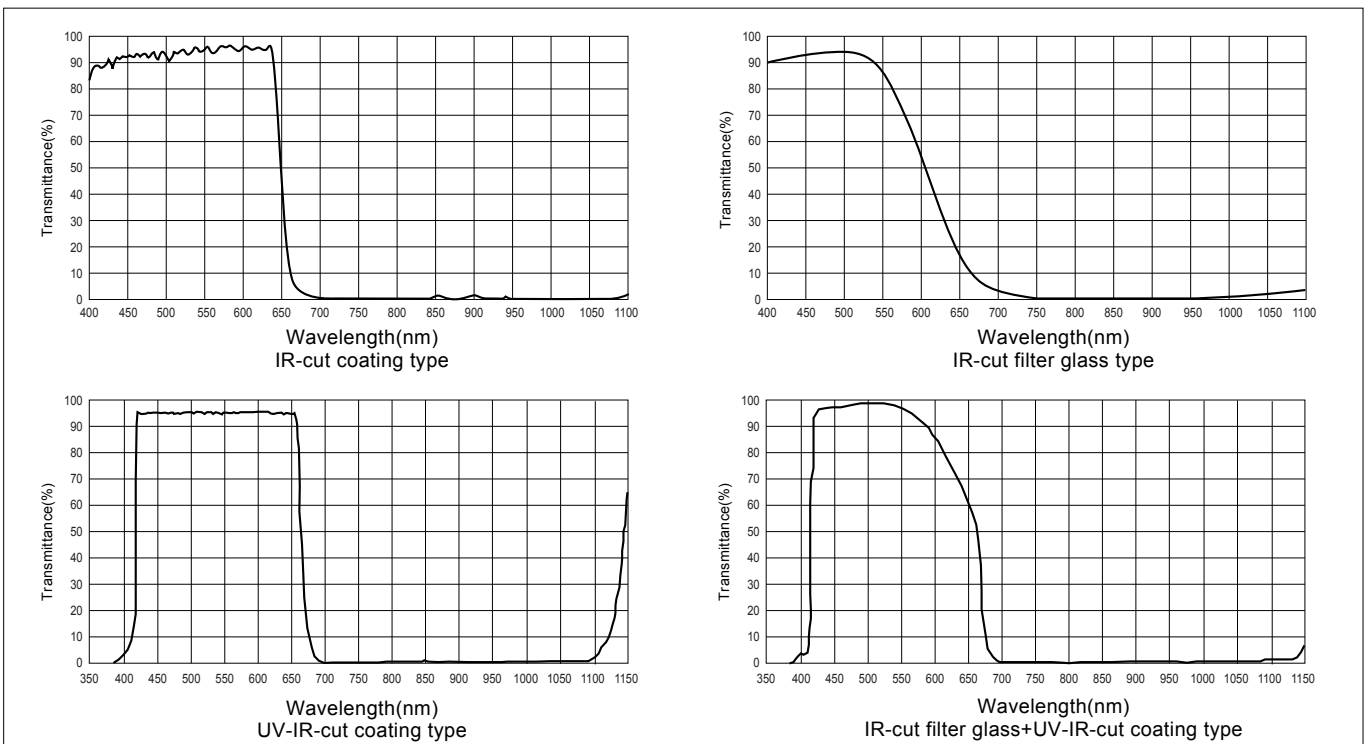

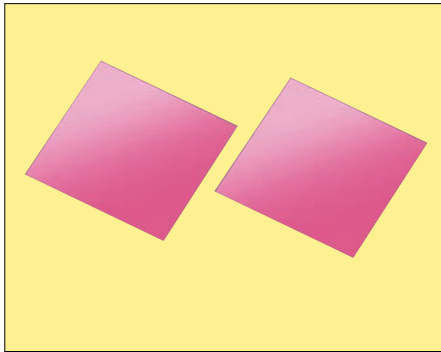

Features

- Made of high quality glass for optical device.
- Available for requirement of various spectrum by infrared cut coating.

Applications

- Camera module for mobile phones.

Specifications

Item	Specifications
Outline dimensions	3~10mm
Flatness	Within 3 Newton rings
Defect limit	30μm MAX.
Transmittance	On discussion

* Please consult us if you require about specification other than above.

Dimensions

	Dimensions
A	3~10mm
B	3~10mm
C	0.3~0.5mm

* Material : Optical glass or Quartz Crystal

- ① Infrared cut coating
- ② Optical glass or Quartz Crystal
- ③ AR coating

Spectral Transmittance Characteristics (Example)

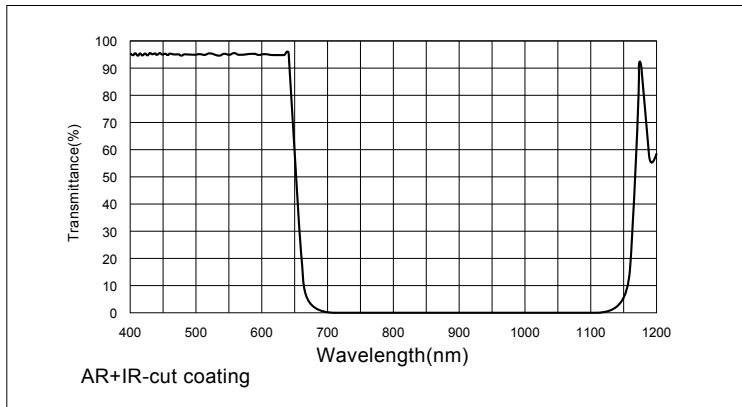

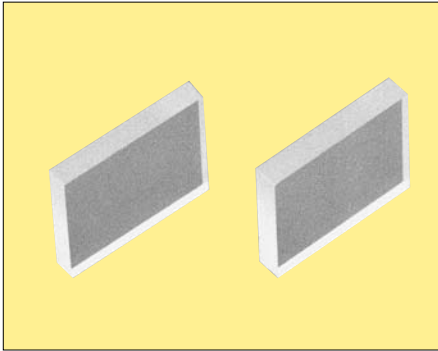

Features

- Made of high quality synthetic quartz crystal for optical device.
- Available with anti-reflective coating for various range of wavelength.

Applications

- CD-RW, DVD-RW.

Specifications

Specifications	Type	Single layer		Double layers	
		1/4Wave	1/2Wave	1/4Wave	1/2Wave
Phase retardation		90°	180°	90°	180°
Phase retardation tolerance		±3°(at center wavelength)			
Crystal plate azimuth		Rotated Z-cut *1		Y-cut or X-cut	
Center wavelength		400nm~800nm			
Optic axis tolerance		±1°			
Outline dimensions(mm)		3 x 3 ~ 6±0.1			
Thickness(mm)		0.4±0.1	0.8±0.1	1.0±0.1	
Angle of incidence		Vertical			
Transmittance		More than 98% (AR coating on both surface)			
Wave front aberration (Transmission)		On discussion			

*1 Please consult us about influence of optical rotating power.

Dimensions

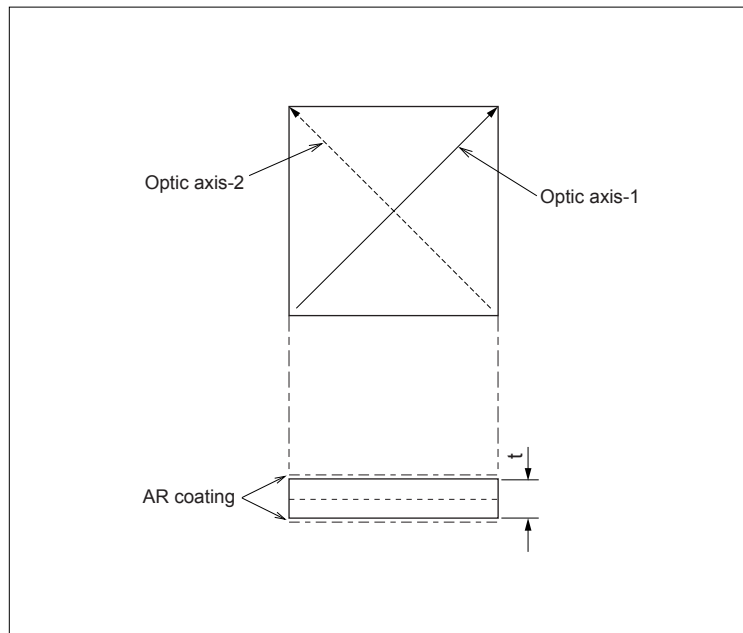

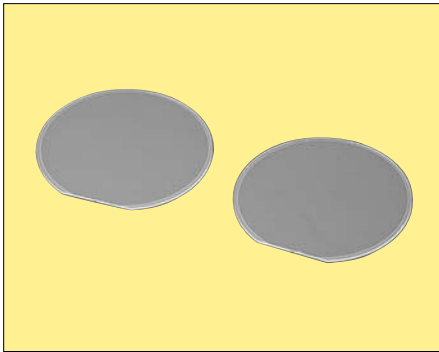

Features

- Made of high quality synthetic quartz crystal for optical device.
- Available with large size aperture.

Applications

- Liquid crystal projector.

Specifications

Specification	Type	Double Layers Quarter Wave Plates
Phase retardation		90°±5°(at center wavelength)
Crystal plate azimuth		Y-cut or X-cut
Wave length		420nm~680nm
Optic axis tolerance		±1°
Outline dimensions(mm)		φ20 x 20~30 x 30*1
Thickness(mm)		0.4~1.0
Angle of incident		Vertical
Transmittance		More than 98% (AR coating on both surface)
Wave front aberration (Transmission)		On discussion

*1 Please consult us if you require about specification other than above.

Dimensions

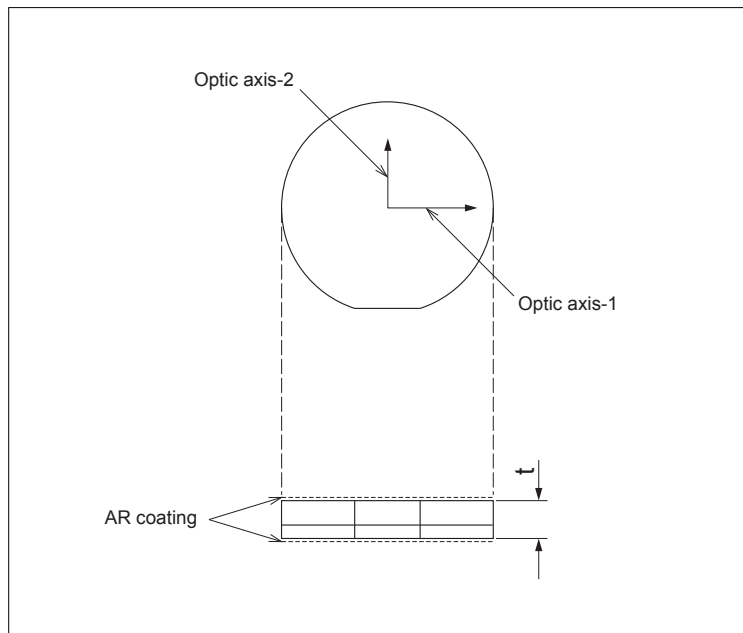

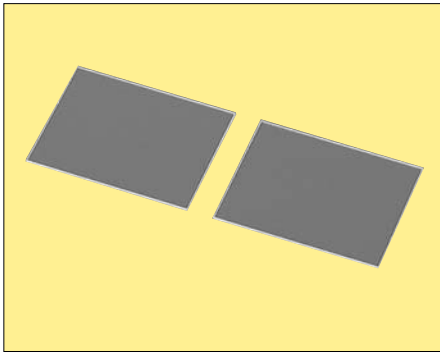

Features

- Excellent thermal radiation characteristics.

Applications

- Liquid crystal projector.

Specifications

Center wave length	420nm~680nm
Outline dimensions(mm)	50 x 50MAX.
Thickness(mm)	0.4~1.0±0.1
Reflectance	Less than 0.5% (One side)
Optic axis tolerance	90°±1°

* Crystal element without AR coating is possible.

Dimensions

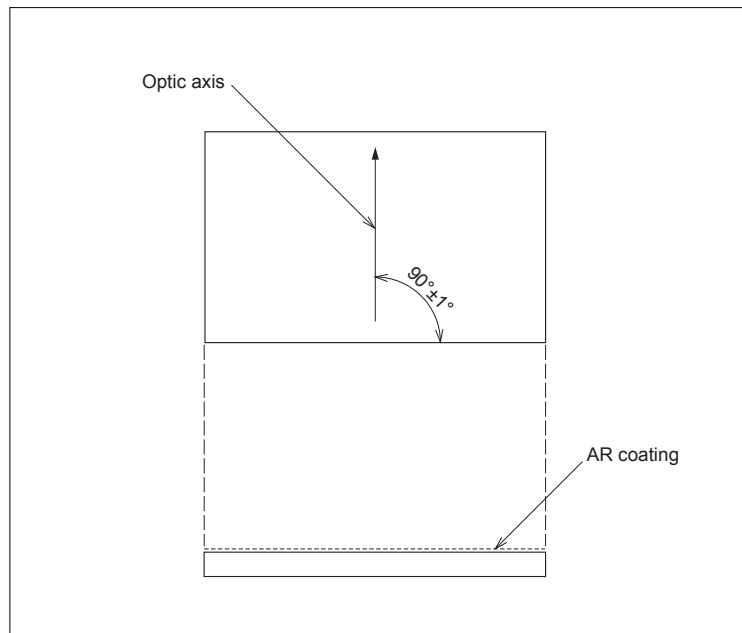

THE NEW VALUE FRONTIER



Filters

SAW Filters
Monolithic Crystal Filters (MCF)





Ph Free

RoHS Compliant

Features

- Small and low profile
- Low insertion loss
- High selectivity
- Withstanding high voltage

Applications

- PCS
- GPS

How to Order

SF 14 - 0906 M 4 UU 01
 ① ② ③ ④ ⑤ ⑥ ⑦

- ① Series
- ② Package Size
- ③ Frequency
- ④ Application
- ⑤ Terminals
- ⑥ Input/Output Condition
- ⑦ Custom Specification

Specifications

Parts No.	Application		Pass Band Frequency	Pass Band Insertion Loss	Pass Band Variation	Pass Band VSWR	Absolute Rejection						Operating Temperature	Storage Temperature	Dimensions	Test Circuit	Recommended Land Pattern	Recommended Land Pattern
							10MHz	720MHz	832MHz	942MHz	1774MHz	2661MHz						
SF14-0906M4UU01	JCDMA	Tx	887MHz 925MHz	3.2dB max.	1.7dB max.	2.2 max.	10MHz 596MHz	720MHz 761MHz	832MHz 870MHz	942MHz 942MHz	1774MHz 1850MHz	2661MHz 2775MHz	-30 to +85°C	-40 to +85°C	Fig. A	Fig. E	Fig. I	Dimensions 1
SF14-2642M5UU01	DMB	Rx	2629MHz 2656MHz	2.0dB max.	1.0dB max.	1.7 max.	0.3 2455MHz	2455MHz	2830MHz	3447.5MHz	3447.5MHz	6000MHz			Fig. B	Fig. F	Fig. J	Dimensions 1
SF16-0881M5UB01	Cell	Differential	869MHz 894MHz	3.0dB max.	1.5dB max.	2.5 max.	0MHz 824MHz	824MHz 849MHz	915MHz 960MHz	960MHz	3000MHz				Fig. D	Fig. G	Fig. L	Dimensions 2
SF16-1575F4UU01	GPS	Front End	1573.92MHz 1576.92MHz	1.8dB max.	1.0dB max.	2.0 max.	810MHz 960MHz	1429MHz 1501MHz	1893MHz 2170MHz						Fig. C	Fig. E	Fig. K	Dimensions 2
SF16-1575M4UU01	GPS	Inter Stage	1573.92MHz 1576.92MHz	1.8dB max.	1.0dB max.	2.5 max.	810MHz 960MHz	1208.22MHz 1210MHz	1207MHz 1210MHz	1522.42MHz	1628.42MHz	1850MHz 1910MHz			Fig. C	Fig. E	Fig. K	Dimensions 2
SF16-1960M5UB01	PCS	Differential	1930MHz 1990MHz	4.1dB max.	2.0dB max.	2.5 max.	0MHz 1850MHz	1850MHz 1910MHz	2040MHz 2200MHz	2200MHz 2800MHz	2800MHz 3400MHz	3400MHz 6000MHz			Fig. D	Fig. G	Fig. L	Dimensions 2

Dimensions

(Unit: mm)

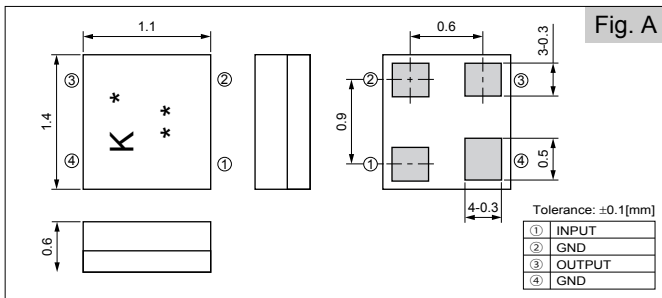

(Unit: mm)

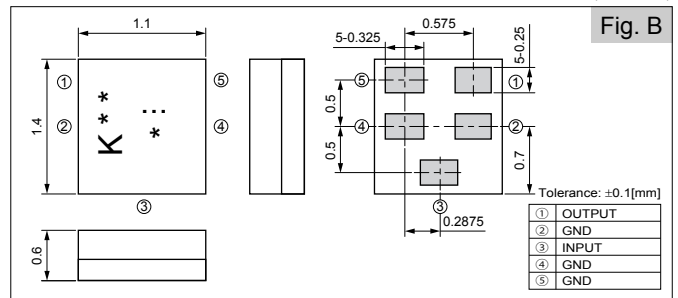

(Unit: mm)

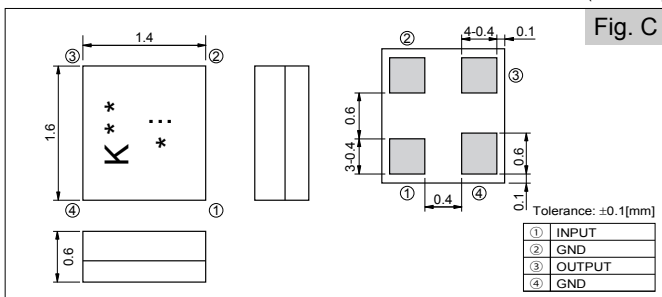

(Unit: mm)

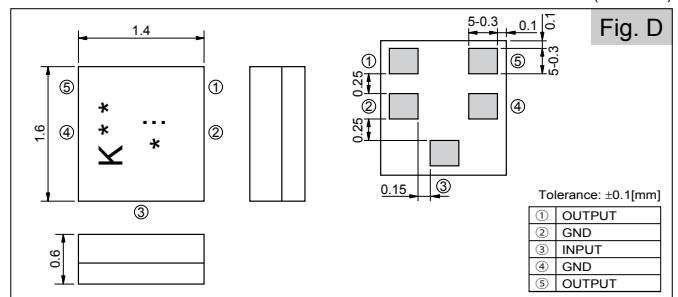

Test Circuit

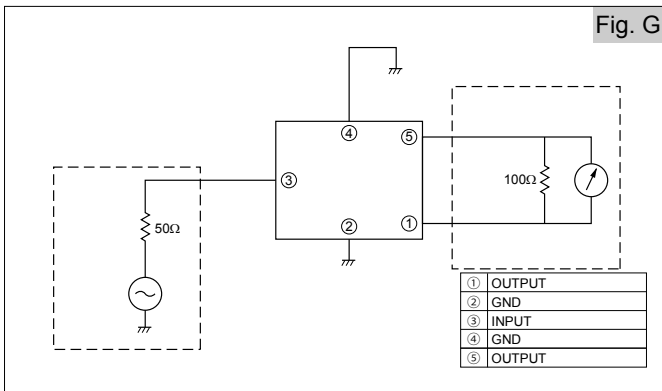
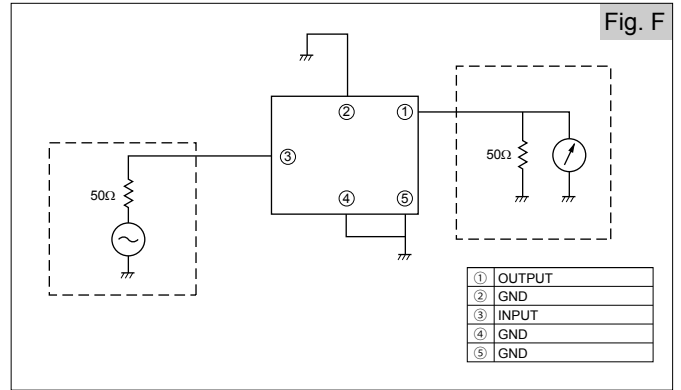
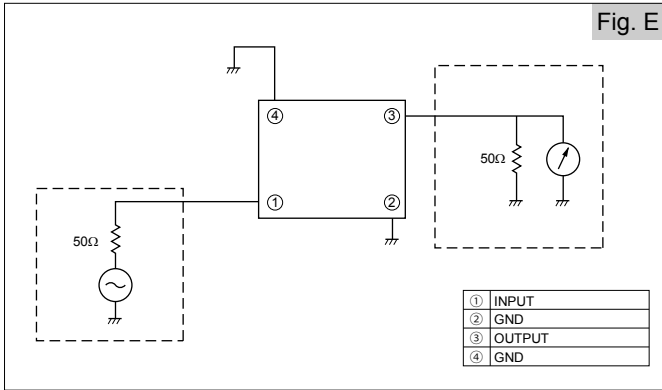

Recommended Land Pattern

(Unit : mm)

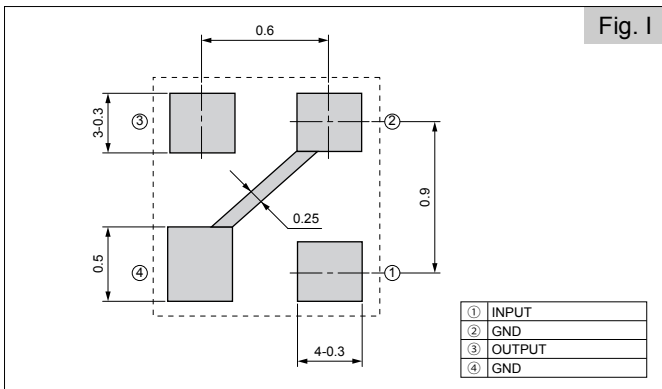

(Unit : mm)

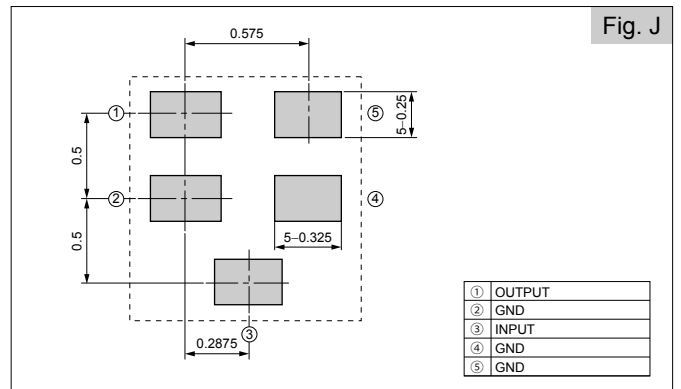

(Unit : mm)

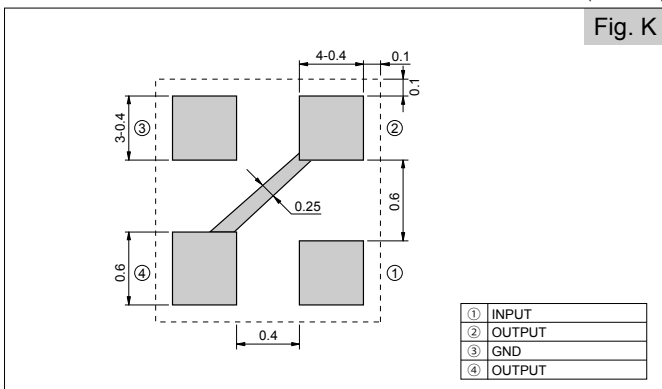

(Unit : mm)

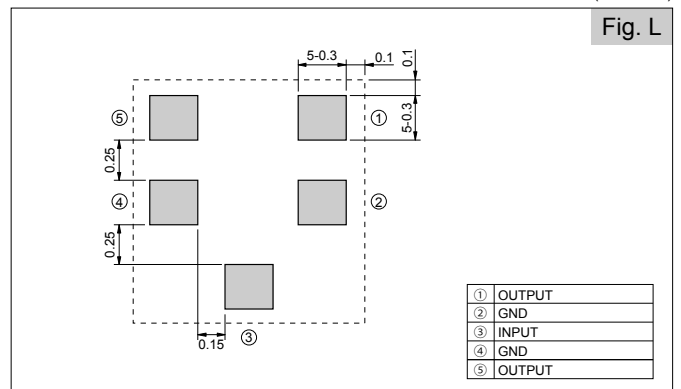

Recommended Temperature Profile IR Reflow

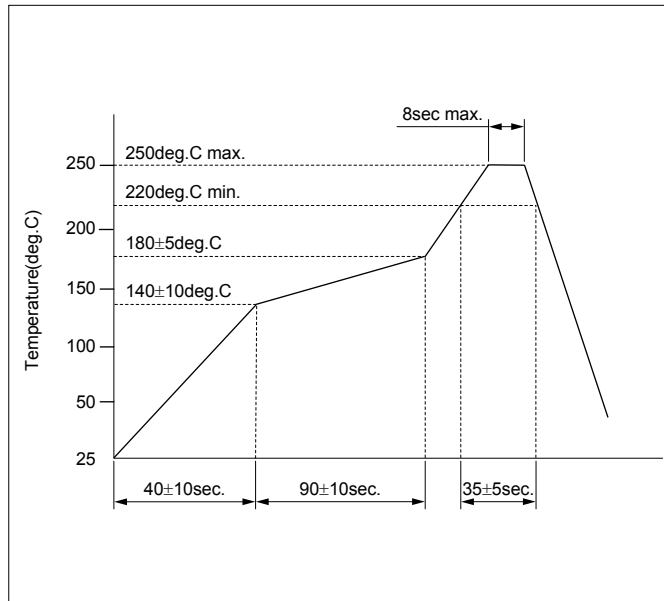

Taping Dimensions

(Unit : mm)

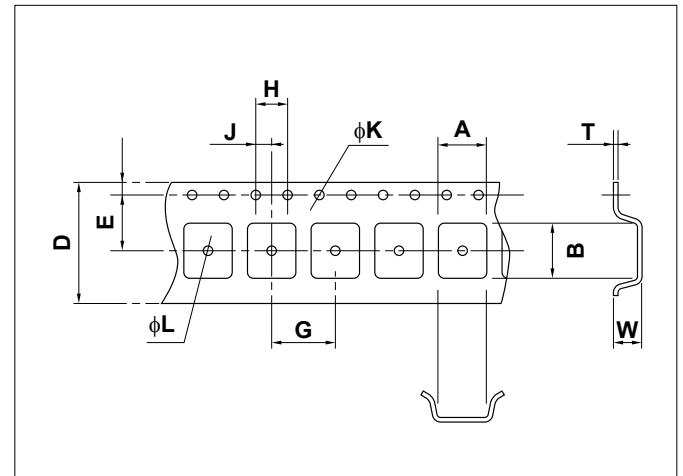

Code	A	B	D	E	G	H	J	K	L	T	W
Dimensions1	1.4	1.7	8.0	3.5	4.0	4.0	2.0	1.50	0.5	0.2	0.8
Dimensions2	1.85	1.9	8.0	3.5	4.0	4.0	2.0	1.50	1.10	0.25	0.95

Characteristics

<JCDMA>Parts No. : SF14-0906M4UU01

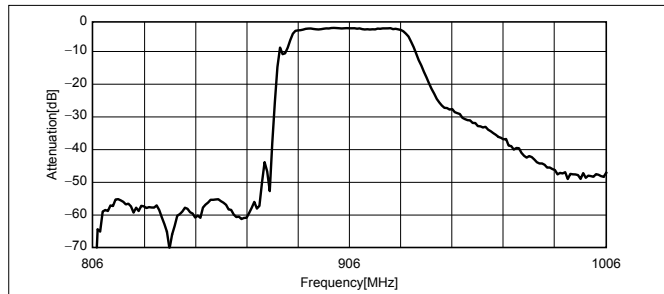

Pass Band Characteristics

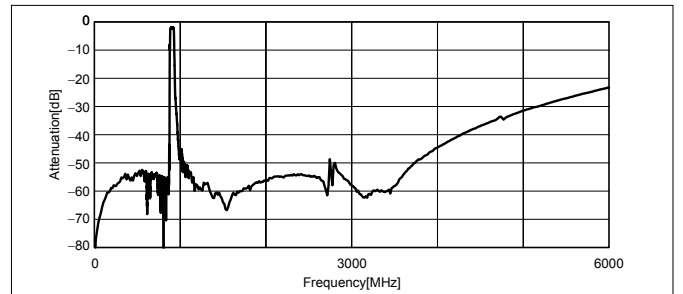

Spurious Characteristics

<DMB>Parts No. : SF14-2642M4UU01

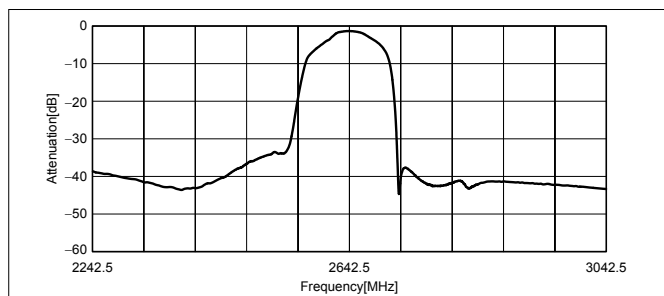

Pass Band Characteristics

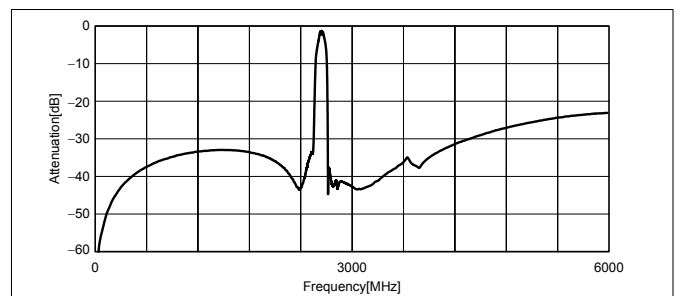

Spurious Characteristics

Characteristics

<GPS Single Front End>Parts No. : SF16-1575F4UU01

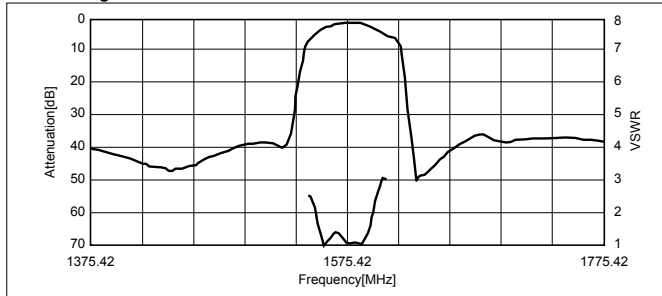

Pass Band Characteristics

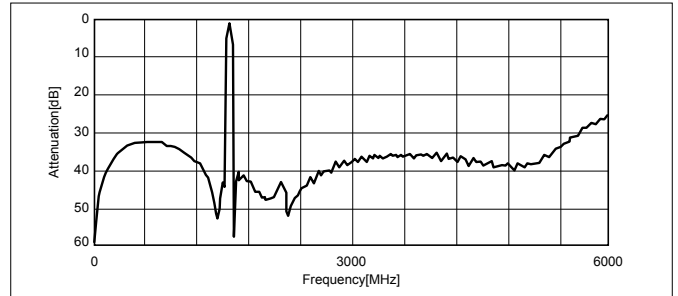

Spurious Characteristics

<GPS Single Front End>Parts No. : SF16-1575M4UU01

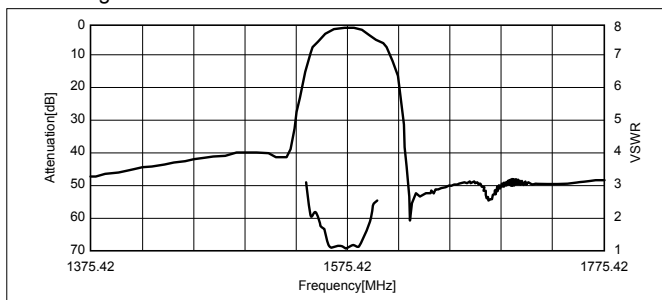

Pass Band Characteristics

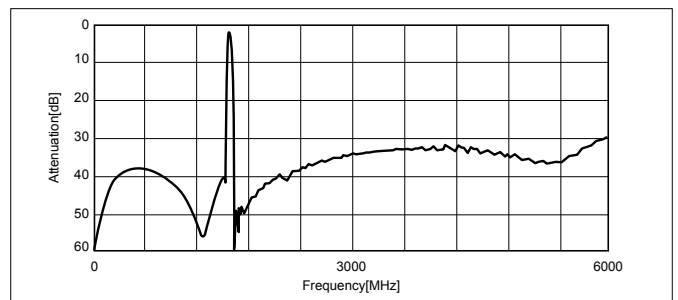

Spurious Characteristics

Characteristics

<Cellular Rx>Parts No. : SF16-0881M5UB01

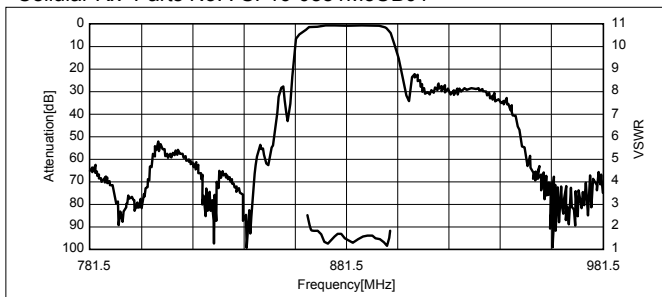

Pass Band Characteristics

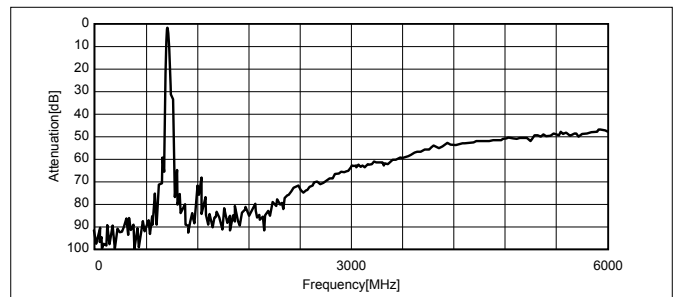

Spurious Characteristics

<PCS Rx>Parts No. : SF16-1960M5UB01

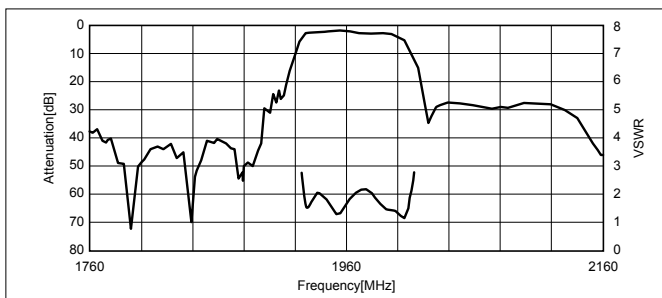

Pass Band Characteristics

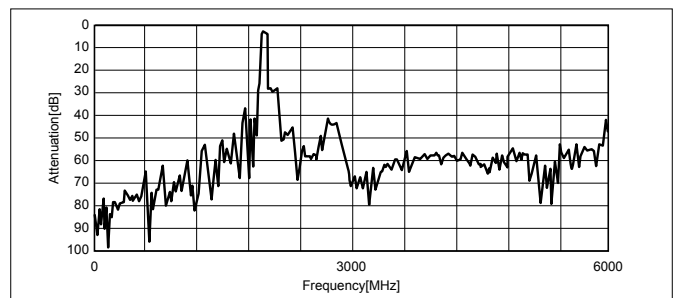

Spurious Characteristics

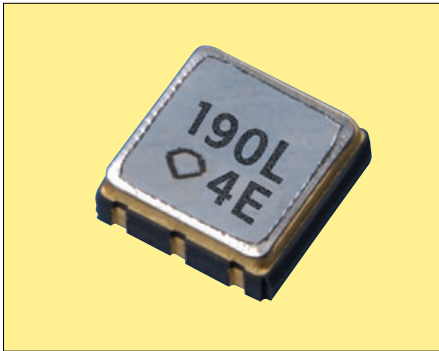

Pb Free

RoHS Compliant

Features

- Wide-band IF filter
- Miniature size and light weight
- Excellent phase characteristics
- Balance connection is available

Standard Frequency

- 190.0MHz

How to Order

SF 3030 B 190M00 B 04M A00
 ① ② ③ ④ ⑤ ⑥ ⑦

- ① Type of Product (SAW Filter)
- ② Package Size (3.0×3.0mm)
- ③ Sealing Type (Seam Weld Type)
- ④ Nominal Frequency (190.00MHz)
- ⑤ Material (Li₂B₄O₇)
- ⑥ Pass Bandwidth (4MHz)
- ⑦ Customer Special Model Suffix (STD)

New Part Number	Old Part Number
SF3030B190M00B04MA00	LSFB71-190-004M0
SF3838B190M00B04MA00	LSFB70-190-004M0

Specifications

Type		SF3030B190M00B04MA00/ SF3838B190M00B04MA00	
Item	Unit	Conditions	Specifications
Nominal Frequency (Fo)	MHz	—	190.000
Operating Temperature Range	°C	-20 to +85°C	—
Storage Temperature Range	°C	-40 to +85°C	—
Pass Bandwidth	MHz	-3dB	Fo±2.3MHz MIN.
Ripple	dB	Fo±2.3MHz	2 MAX.
Insertion Loss	dB	Fo	7 MAX.
Guaranteed Attenuation	dB	Fo±5 to ±7.5MHz	10 MIN.
		Fo±7.5 to ±12.5MHz	25 MIN.
		Fo±12.5 to ±100MHz	40 MIN.
Group Delay Deviation	ns	Fo±2MHz	100 MAX.

Dimensions

(Unit : mm)

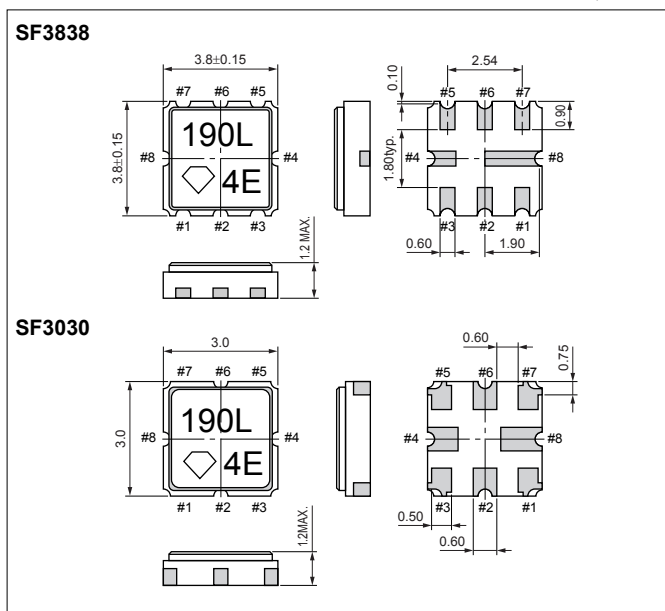

Recommended Land Pattern

(Unit : mm)

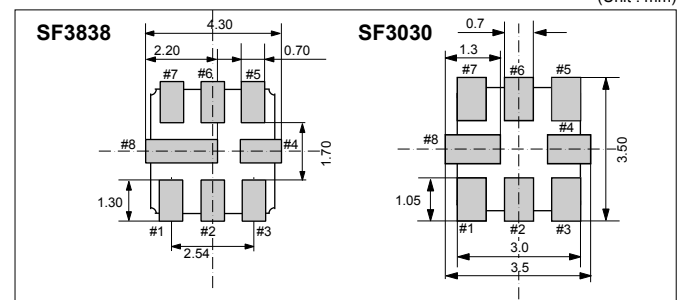

Test Circuit

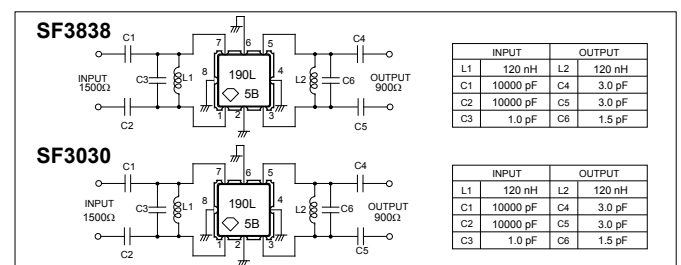

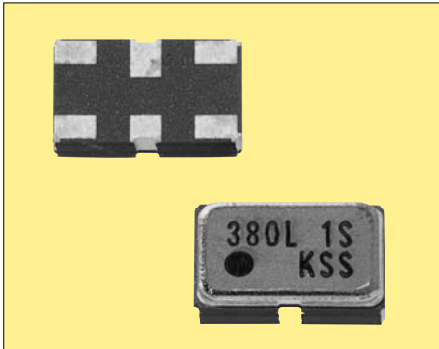

Pb Free

RoHS Compliant

Features

- Wide-band IF filter for W-CDMA
- Miniature size and light weight
- Excellent phase characteristics
- Balance connection is available

Standard Frequency

- 380MHz
- 190MHz

How to Order

SF 5032 B 380M00 B 03M A00
 ① ② ③ ④ ⑤ ⑥ ⑦

- ① Type of Product (SAW Filter)
- ② Package Size (5.0×3.2mm)
- ③ Sealing Type (Seam Weld Type)
- ④ Nominal Frequency (380MHz)
- ⑤ Material (Li₂B₄O₇)
- ⑥ Pass Bandwidth (3.84MHz)
- ⑦ Customer Special Model Suffix (STD)

New Part Number	Old Part Number
SF5032B380M00B03MA00	LSFB54-380-004M0
SF5032B190M00B03MA02	LSFB54-190-004M2

Specifications

Type		SF5032B190M00B03MA02		SF5032B380M00B03MA00	
Item	Unit	Conditions	Specifications	Conditions	Specifications
Nominal Frequency (Fo)	MHz	—	190.000	—	380.000
Operating Temperature Range	°C	-20 to +75°C	—	-20 to +75°C	—
Storage Temperature Range	°C	-40 to +80°C	—	-40 to +80°C	—
Pass Bandwidth	MHz	-3dB	Fo±1.92MHz MIN.	-3dB	Fo±1.92MHz MIN.
Ripple	dB	±1.92MHz	1.5 MAX.	±1.92MHz	2 MAX.
Insertion Loss	dB	Minimum Loss	9 MAX.	Maximum Loss (±1.92MHz)	10 MAX.
Guaranteed Attenuation	dB	Fo± 5MHz	20 MIN.	Fo±5MHz	25 MIN.
		Fo±10MHz	40 MIN.	Fo± 10MHz	30 MIN.
Group Delay Deviation	ns	Fo±1.92MHz	140 MAX.	Fo± 1.92MHz	300 MAX.

Dimensions

(Unit : mm)

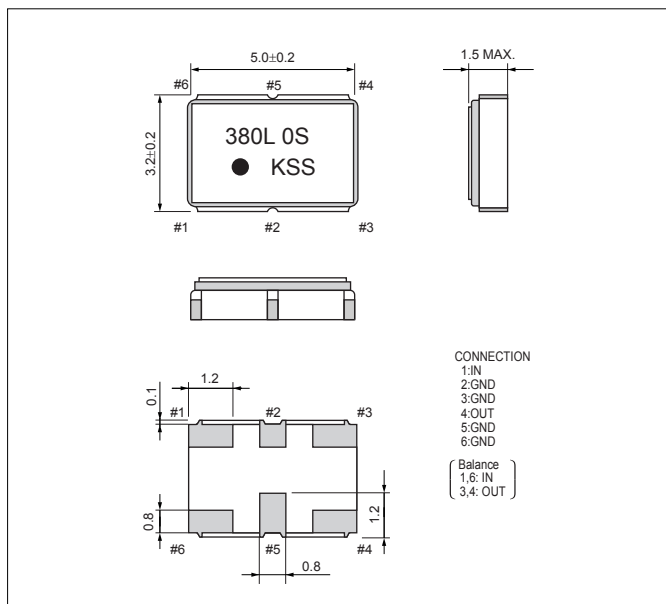

Recommended Land Pattern

(Unit : mm)

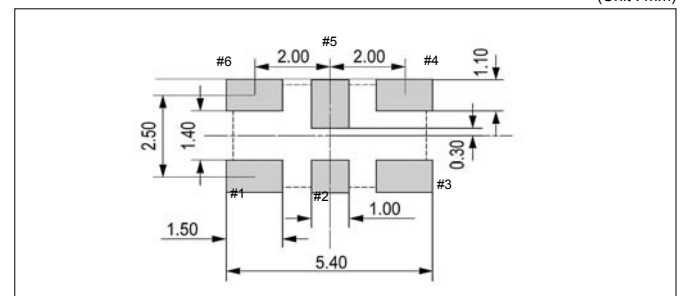

Test Circuit

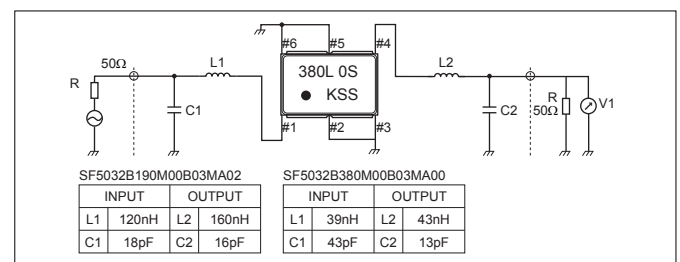

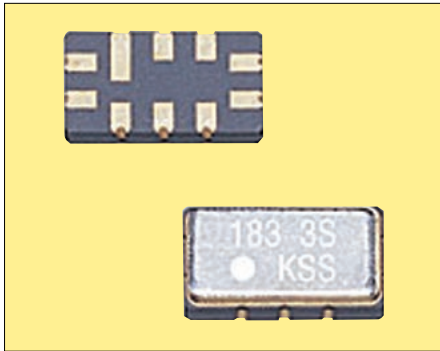

Pb Free

RoHS Compliant

Features

- Miniature size and light weight
- Wide-Band IF filter for CDMA
- Excellent group delay distortion
- Balance connection is available

Standard Frequency

- 183.6MHz

How to Order

SF 6035 B 183M60 C 01M A00
① ② ③ ④ ⑤ ⑥ ⑦

- ① Type of Product (SAW Filter)
- ② Package Size (6.0×3.5mm)
- ③ Sealing Type (Seam Weld Type)
- ④ Nominal Frequency (183.6MHz)
- ⑤ Material (Quartz Crystal)
- ⑥ Pass Bandwidth (1.23MHz)
- ⑦ Customer Special Model Suffix (STD)

New Part Number	Old Part Number
SF6035B183M60C01MA00	MSFB55-183-001M0

Specifications

Item	Unit	Conditions	Specifications
Nominal Frequency (Fo)	MHz	————	183.6
Operating Temperature Range	°C	-30 to +80	————
Storage Temperature Range	°C	-40 to +85	————
Pass Bandwidth	kHz	-5dB	±650* ±615 MIN.
Ripple	dB	Fo±300kHz	0.3* 1.0 MAX.
Insertion Loss	dB	Minimum Loss	8.0* 10.5 MAX.
Guaranteed Attenuation	dB	Fo±900kHz	-900/40* 33 MIN.
			+900/40* 33 MIN.
		Fo±1.25MHz	-1.25/39* 33 MIN.
			+1.25/40* 33 MIN.
Group Delay Deviation	ns	Fo±300kHz	250* 500 MAX.

* : Typ.

Dimensions

(Unit : mm)

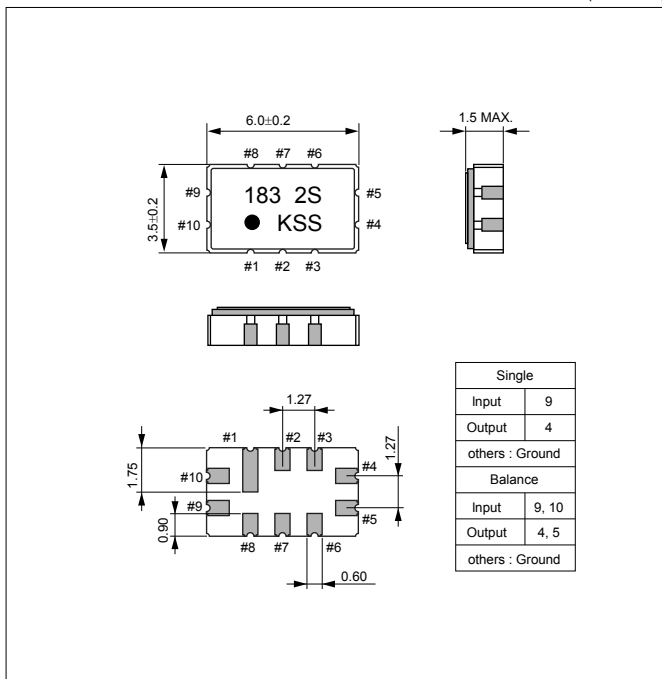

Recommended Land Pattern

(Unit : mm)

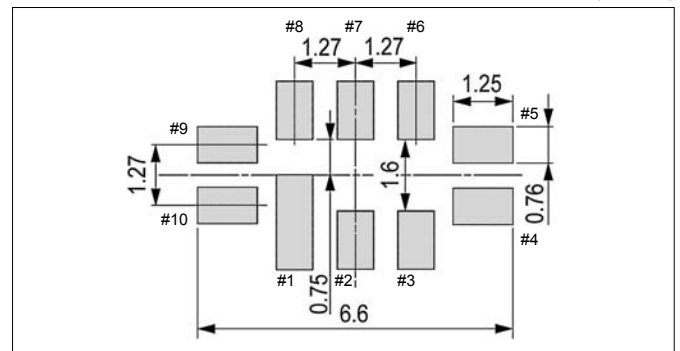

Test Circuit

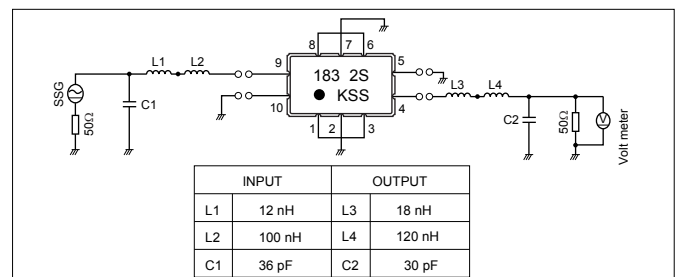

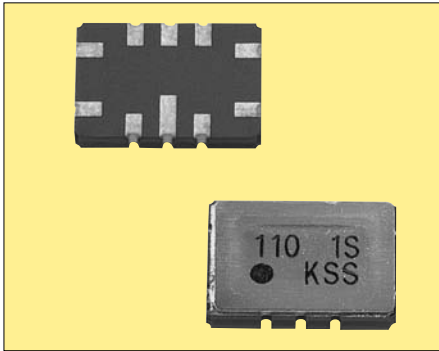

Please contact us about Pb free status.

Features

- Wide-band IF filter for cdmaOne
- Excellent phase characteristics
- Balance connection is available

Standard Frequency

- 110.0MHz

How to Order

SF 7050 C 110M00 C 01M A00
 ① ② ③ ④ ⑤ ⑥ ⑦

- ① Type of Product (SAW Filter)
- ② Package Size (7.0×5.0mm)
- ③ Sealing Type (Solder Weld Type)
- ④ Nominal Frequency (110MHz)
- ⑤ Material (Quartz Crystal)
- ⑥ Pass Bandwidth (1.24MHz)
- ⑦ Customer Special Model Suffix (STD)

New Part Number	Old Part Number
SF7050C110M00C01MA00	MSFC30-110-001M0

Specifications

Item	Unit	Conditions	Specifications
Nominal Frequency (Fo)	MHz	—	110.00
Operating Temperature Range	°C	-30 to +80	—
Storage Temperature Range	°C	-40 to +85	—
Pass Bandwidth	kHz	-5dB	-645*
			+670*
			±620 MIN.
Ripple	dB	Fo±300kHz	0.2*
Insertion Loss	dB	Minimum Loss	9.4*
Guaranteed Attenuation	dB	Fo±900kHz	-900/43*
			+900/40*
		Fo±1.7MHz	-1.7/43*
			+1.7/38*
			33 MIN.
			33 MIN.
Group Delay Deviation	ns	Fo±300kHz	280*
			500 MAX.

* : Typ.

Dimensions

(Unit : mm)

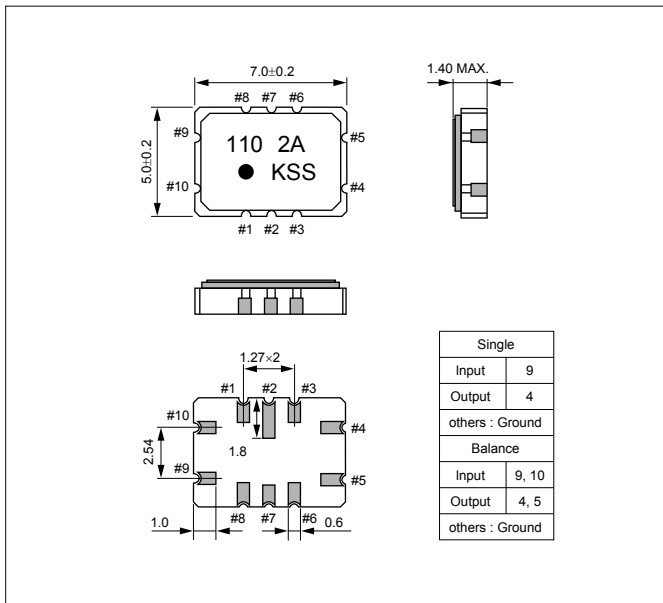

Recommended Land Pattern

(Unit : mm)

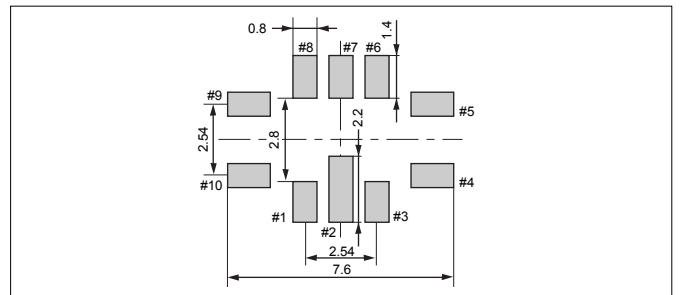

Test Circuit

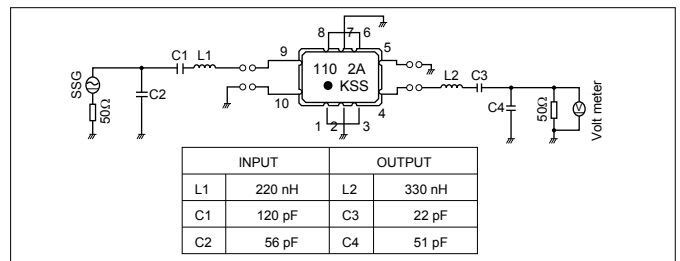

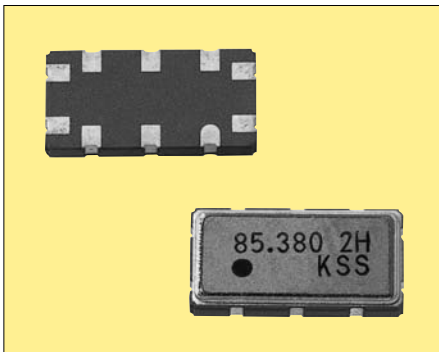

Pb Free

RoHS Compliant

Features

- Wide-band IF filter for cdmaOne
- Miniature size and light weight
- Excellent phase characteristics
- Balance connection is available

Standard Frequency

- 85.380MHz

How to Order

SF 9148 B 085M38 C 01M A00
 ① ② ③ ④ ⑤ ⑥ ⑦

- ① Type of Product (SAW Filter)
- ② Package Size (9.1×4.8mm)
- ③ Sealing Type (Seam Weld Type)
- ④ Nominal Frequency (85.380MHz)
- ⑤ Material (Quartz Crystal)
- ⑥ Pass Bandwidth (1.24MHz)
- ⑦ Customer Special Model Suffix (STD)

New Part Number	Old Part Number
SF9148B085M38C01MA00	MSFB43-85-001M0

Specifications

Item	Unit	Conditions	Specifications
Nominal Frequency (Fo)	MHz	—	85.38
Operating Temperature Range	°C	-30 to +80	—
Storage Temperature Range	°C	-40 to +85	—
Pass Bandwidth	kHz	-5dB	-640*
			+650*
			±620 MIN.
Ripple	dB	Fo±300kHz	0.4*
			1 MAX.
Insertion Loss	dB	Fo	9.1*
			12 MAX.
Guaranteed Attenuation	dB	Fo±900kHz	-900/48*
			+900/42*
			33 MIN.
Group Delay Deviation	ns	Fo±300kHz	270*
			500 MAX.

* : Typ.

Dimensions

(Unit : mm)

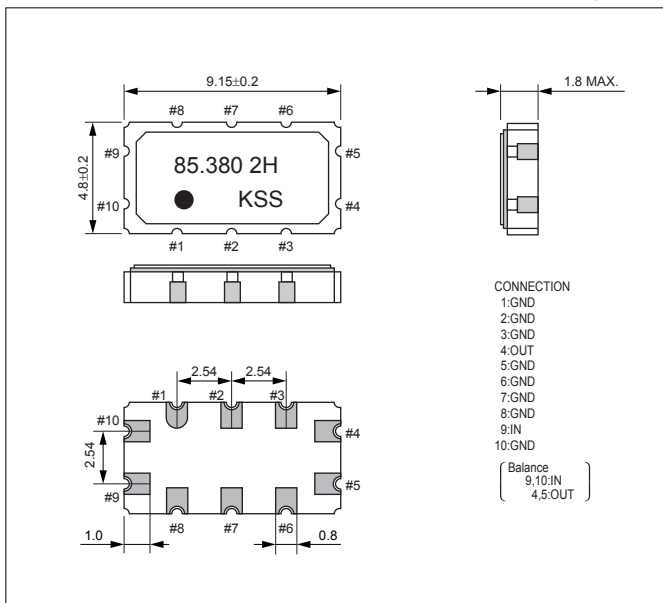

Recommended Land Pattern

(Unit : mm)

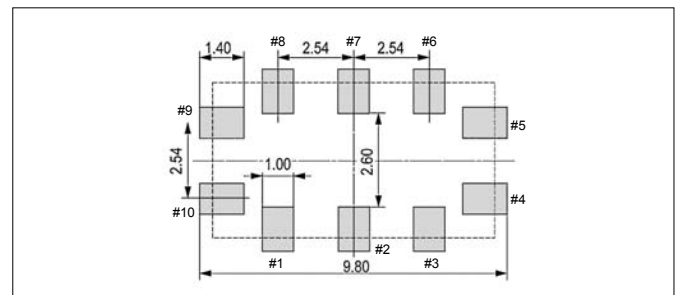

Test Circuit

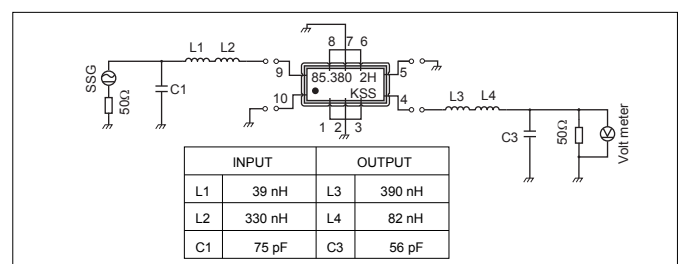



Ph Free

RoHS Compliant

Features

- IF filter for SCDMA
- Miniature size and light weight
- Excellent phase characteristics
- Balance connection is available

Standard Frequency

- 204MHz

How to Order

SF 7050 B 204M00 C 600 A00
 ① ② ③ ④ ⑤ ⑥ ⑦

- ① Type of Product (SAW Filter)
- ② Package Size (7.0×5.0mm)
- ③ Sealing Type (Seam Weld Type)
- ④ Nominal Frequency (204.00MHz)
- ⑤ Material (Quartz Crystal)
- ⑥ Pass Bandwidth (600kHz)
- ⑦ Customer Special Model Suffix (STD)

New Part Number	Old Part Number
SF7050B204M00C600A00	MSFB30-204-600K0

Specifications

Item	Unit	Conditions	Specifications
Nominal Frequency (Fo)	MHz	—	204.000
Operating Temperature Range	°C	-20 to +70°C	—
Storage Temperature Range	°C	-40 to +85°C	—
Pass Bandwidth	kHz	-1dB	Fo±225
Insertion Loss	dB	Fo	8.8 MAX.
Guaranteed Attenuation	dB	Fo±1MHz	30 MIN.
		Fo±2MHz	40 MIN.
Group Delay Deviation	ns	Fo±225kHz	300 MAX.

Dimensions

(Unit : mm)

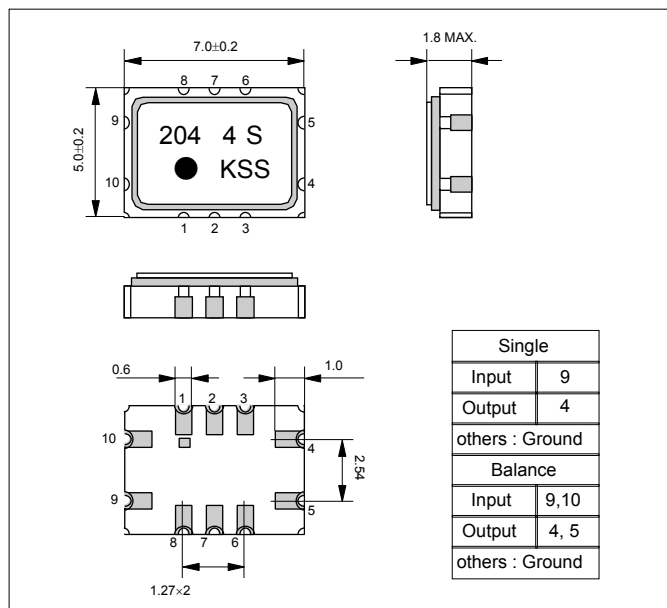

Recommended Land Pattern

(Unit : mm)

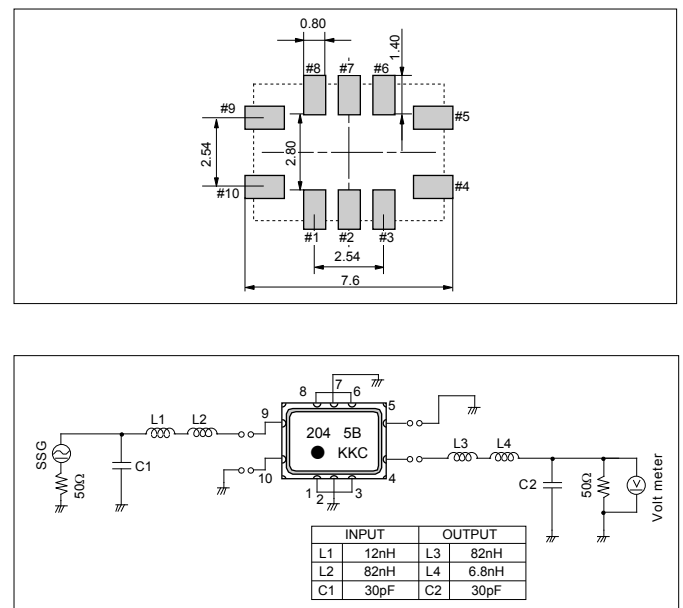

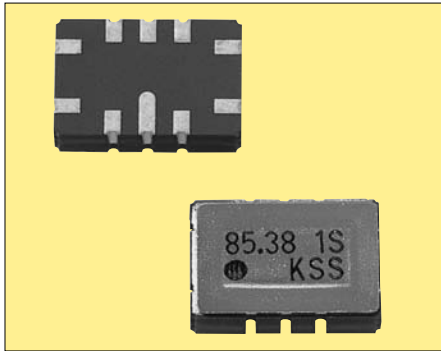

Please contact us about Pb free status.

Features

- Narrow-band IF filter for AMPS
- Miniature size and light weight
- Excellent group delay distortion

Standard Frequency

- 83.16MHz
- 85.38MHz

How to Order

SF 7050 C 083M16 C 026 A00
 ① ② ③ ④ ⑤ ⑥ ⑦

- ① Type of Product (SAW Filter)
- ② Package Size (7.0×5.0mm)
- ③ Sealing Type (Solder Weld Type)
- ④ Nominal Frequency (83.16MHz)
- ⑤ Material (Quartz Crystal)
- ⑥ Pass Bandwidth (26kHz)
- ⑦ Customer Special Model Suffix (STD)

New Part Number	Old Part Number
SF7050C083M16C026A00	MSFC12-83-026K0
SF7050C085M38C026A01	MSFC12-85-026K1

Specifications

Type	Unit	SF7050C083M16C026A00		SF7050C085M38C026A01	
		Conditions	Specifications	Conditions	Specifications
Nominal Frequency (Fo)	MHz	—	83.16	—	85.38
Operating Temperature Range	°C	-25 to +75	—	-30 to +80	—
Storage Temperature Range	°C	-35 to +85	—	-40 to +85	—
Pass Bandwidth	kHz	-3dB	Fo±13 MIN.	-3dB	Fo±13 MIN.
Ripple	dB	Fo±13kHz	0* 1.5 MAX.	Fo±10kHz	0* 1.5 MAX.
Insertion Loss	dB	Minimum Loss	3.5* 5 MAX.	Minimum Loss	3.5* 5 MAX.
		Fo-120kHz	64* 50 MIN.	Fo-120kHz	59* 40 MIN.
		Fo±60kHz	35* 25 MIN.	Fo±60kHz	33* 25 MIN.
Guaranteed Attenuation	dB	Fo+120kHz	60* 50 MIN.	Fo+120kHz	65* 40 MIN.
		Fo±13kHz	6* 10 MAX.	Fo±10kHz	5* 12 MAX.
Group Delay Deviation	μS	Fo±13kHz	6* 10 MAX.	Fo±10kHz	5* 12 MAX.
Terminating Impedance	Ω/pF	—	810//1.5	MSFC12	980//1.2

* : Typ.

* : Typ.

Dimensions

(Unit : mm)

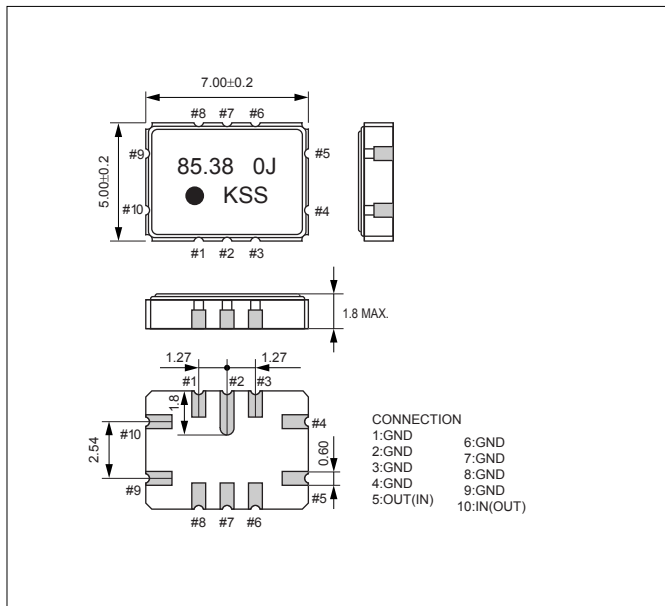

Recommended Land Pattern

(Unit : mm)

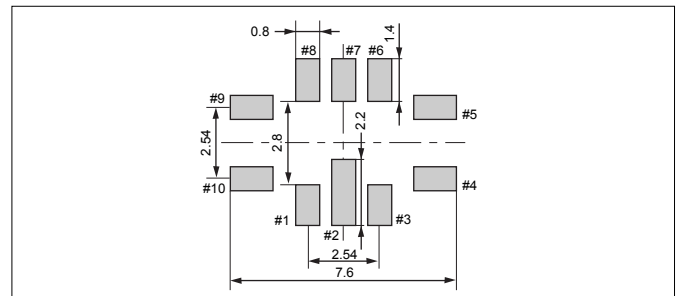

Test Circuit

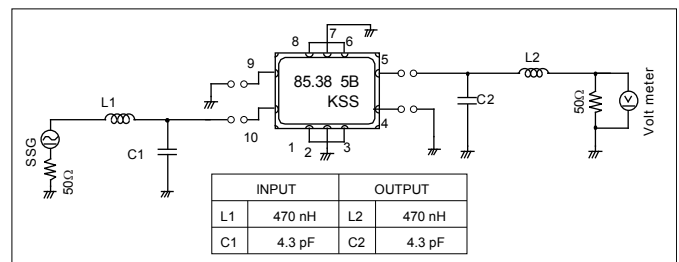

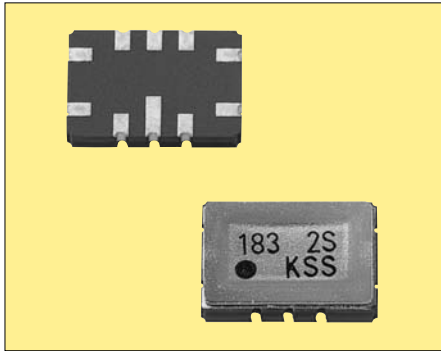

Please contact us about Pb free status.

Features

- Narrow-band IF filter for AMPS
- Miniature size and light weight
- Excellent group delay distortion

Standard Frequency

- 183.6MHz

How to Order

SF 7050 C 183M60 C 022 B00
 ① ② ③ ④ ⑤ ⑥ ⑦

- ① Type of Product (SAW Filter)
- ② Package Size (7.0×5.0mm)
- ③ Sealing Type (Solder Weld Type)
- ④ Nominal Frequency (183.6MHz)
- ⑤ Material (Quartz Crystal)
- ⑥ Pass Bandwidth (22kHz)
- ⑦ Customer Special Model Suffix (STD)

New Part Number	Old Part Number
SF7050C183M60C22B00	MSFC30-183-022K0

Specifications

Item	Unit	Conditions	Specifications	
Nominal Frequency (Fo)	MHz	—	183.6	
Operating Temperature Range	°C	-25 to +75	—	
Storage Temperature Range	°C	-35 to +85	—	
Pass Bandwidth	kHz	-3dB	±11 MIN.	
Ripple	dB	Fo±11kHz	0* 1.5 MAX.	
Insertion Loss	dB	Minimum Loss	4.5* 5.5 MAX.	
Guaranteed Attenuation	dB	Fo±60kHz	-60/27	11 MIN.
			+60/21	
Guaranteed Attenuation	dB	Fo±120kHz	-120/51	40 MIN.
			+120/49	
Group Delay Deviation	µs	Fo±11kHz	1.2* 15 MAX.	

* : Typ.

Dimensions

(Unit : mm)

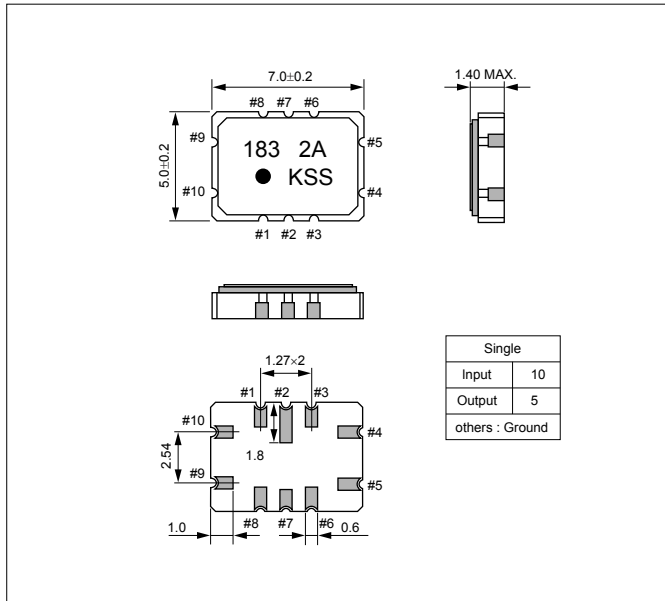

Recommended Land Pattern

(Unit : mm)

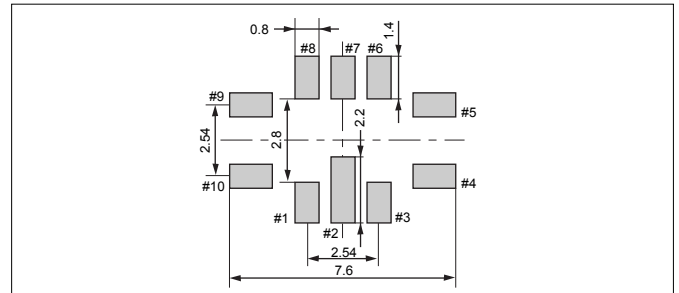

Test Circuit

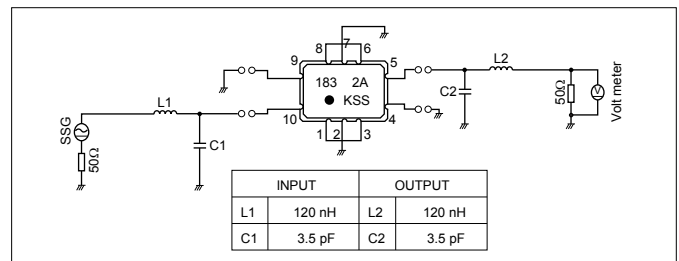



Pb Free

RoHS Compliant

Features

- RF filter for RKE (Remote Keyless Entry)
- Miniature size and light weight
- Excellent temperature characteristics (SF3838B315M00C300A00)
- Excellent attenuation (SF3838B315M00B200A00)

Standard Frequency

- 315MHz

How to Order

SF 3838 B 315M00 C 300 A00
 ① ② ③ ④ ⑤ ⑥ ⑦

- ① Type of Product (SAW Filter)
- ② Package Size (3.8×3.8mm)
- ③ Sealing Type (Seam Weld Type)
- ④ Nominal Frequency (315.00MHz)
- ⑤ Material (Quartz Crystal)
- ⑥ Pass Bandwidth (300kHz)
- ⑦ Customer Special Model Suffix (STD)

Specifications

Type		SF3838B315M00C300A00		SF3838B315M00B200A00	
Item	Unit	Conditions	Specifications	Conditions	Specifications
Nominal Frequency	MHz	—	315.000	—	315.000
Operating Temperature Range	°C	-40 to +105°C	—	-40 to +85°C	—
Storage Temperature Range	°C	-40 to +105°C	—	-40 to +85°C	—
Pass Bandwidth	kHz	-3dB	Fo±150 MIN.	-3dB	Fo±100 MIN.
Insertion Loss	dB	MIN.	2.5 MAX.	MIN.	3 MAX.
Guaranteed Attenuation	dB	10 to 303.5MHz	45 MIN.	Fo±5MHz	40 MIN.
		303.5 to 311MHz	25 MIN.	Fo±10MHz	55 MIN.
		325 to 600MHz	35 MIN.	—	—
		600 to 1000MHz	60 MIN.	—	—
Ripple	dB	—	1dB MAX.	—	—

Dimensions

(Unit : mm)

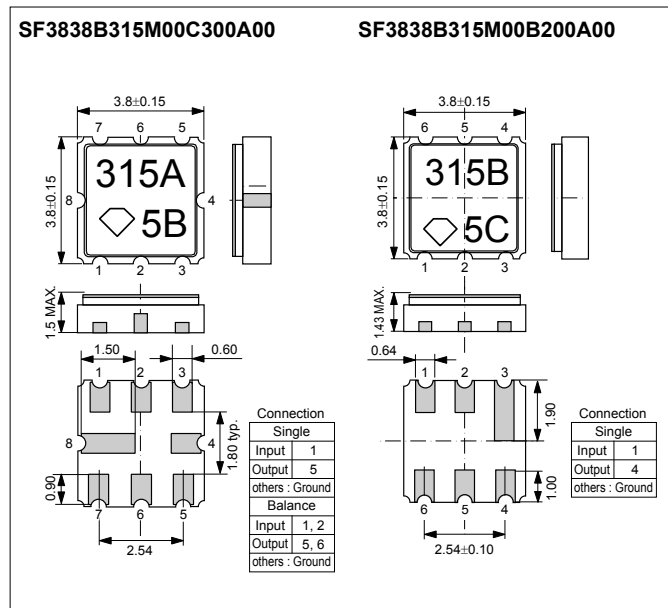

Recommended Land Pattern

(Unit : mm)

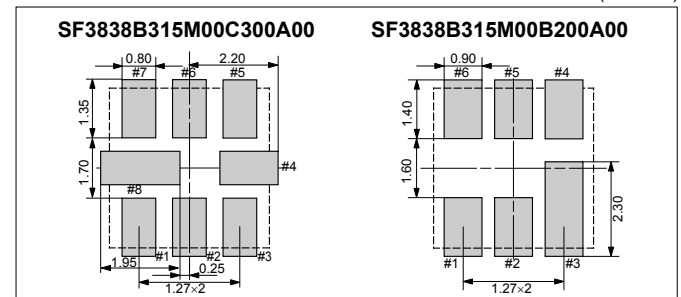

Test Circuit

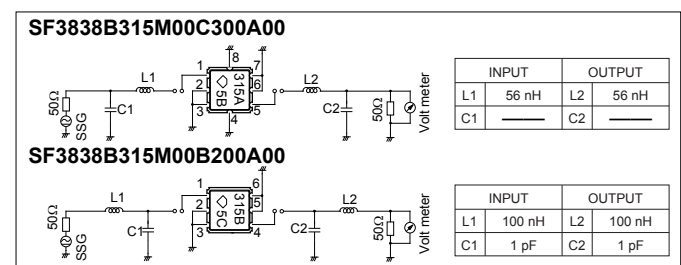

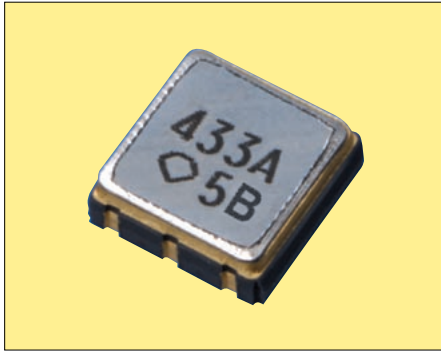

Features

- RF filter for RKE (Remote Keyless Entry)
- Miniature size and light weight
- Excellent temperature characteristics (SF3838B433M92C300A00)
- Excellent attenuation (SF3838B433M92B200A00)

Standard Frequency

- 433.92MHz

How to Order

SF 3838 B 433M92 C 300 A00
 ① ② ③ ④ ⑤ ⑥ ⑦

- ① Type of Product (SAW Filter)
- ② Package Size (3.8×3.8mm)
- ③ Sealing Type (Seam Weld Type)
- ④ Nominal Frequency (433.92MHz)
- ⑤ Material (Quartz Crystal)
- ⑥ Pass Bandwidth (300kHz)
- ⑦ Customer Special Model Suffix (STD)

Pb Free

RoHS Compliant

Specifications

Type		SF3838B433M92C300A00		SF3838B433M92B200A00	
Item	Unit	Conditions	Specifications	Conditions	Specifications
Nominal Frequency	MHz	—	433.920	—	433.920
Operating Temperature Range	°C	-40 to +105°C	—	-40 to +85°C	—
Storage Temperature Range	°C	-40 to +105°C	—	-40 to +85°C	—
Pass Bandwidth	kHz	-3dB	Fo±150 MIN.	-3dB	Fo±100 MIN.
Insertion Loss	dB	MIN.	2.5 MAX.	MIN.	3 MAX.
Guaranteed Attenuation	dB	10 to 424MHz	45 MIN.	Fo±5MHz	40 MIN.
		424 to 432MHz	25 MIN.	Fo±10.7MHz	55 MIN.
		445 to 800MHz	45 MIN.	Fo±21.4MHz	60 MIN.
		800 to 1000MHz	60 MIN.	—	—
Ripple	dB	—	1dB MAX.	—	—

Dimensions

(Unit : mm)

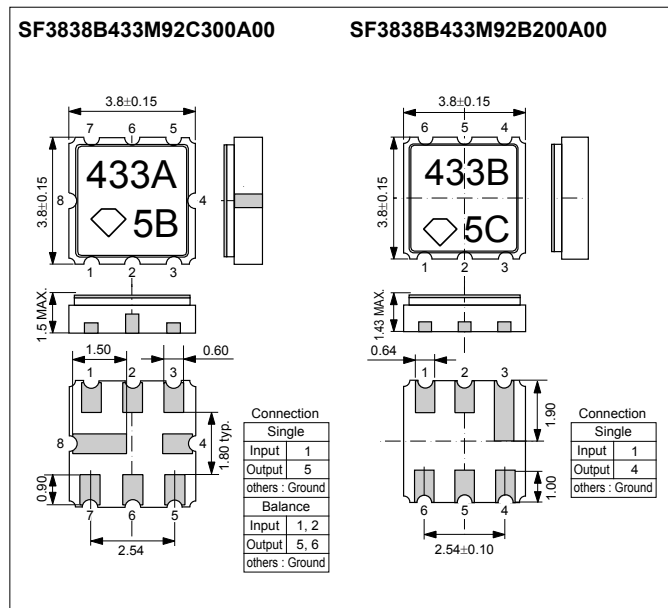

Recommended Land Pattern

(Unit : mm)

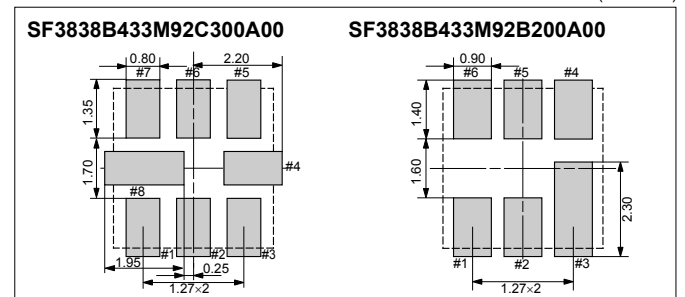

Test Circuit

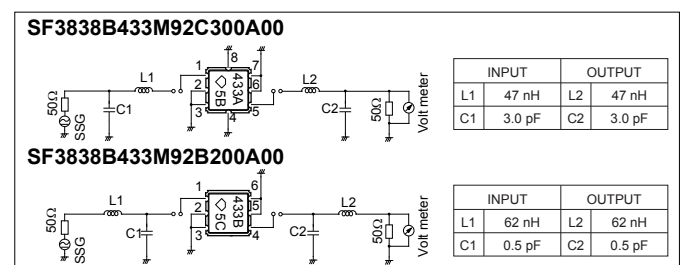

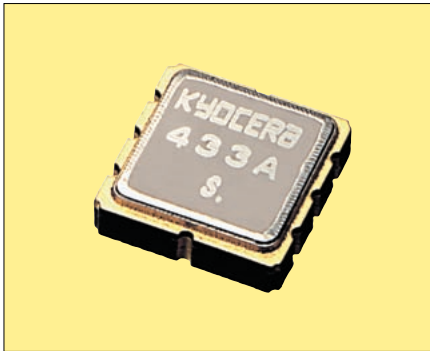

Features

- Small and low profile
- Flat pass band characteristics
- Low insertion loss
- Excellent temperature stability

Application

- Remote Keyless Entry

How to Order

PAFC 433.92 AR 00
① ② ③ ④

- ① Series
- ② Center Frequency
- ③ Type
- ④ Option

Pb Free

RoHS Compliant

Dimensions

(Unit : mm)

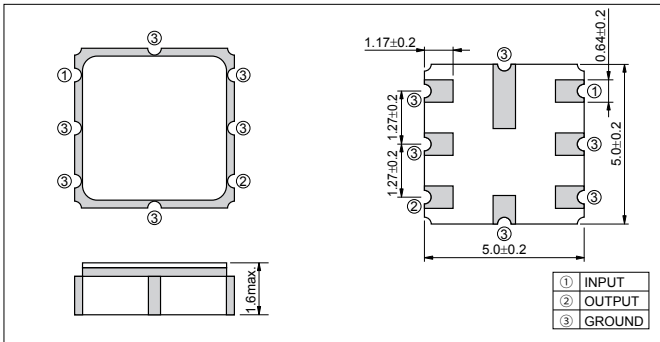

Recommended Land Pattern

(Unit : mm)

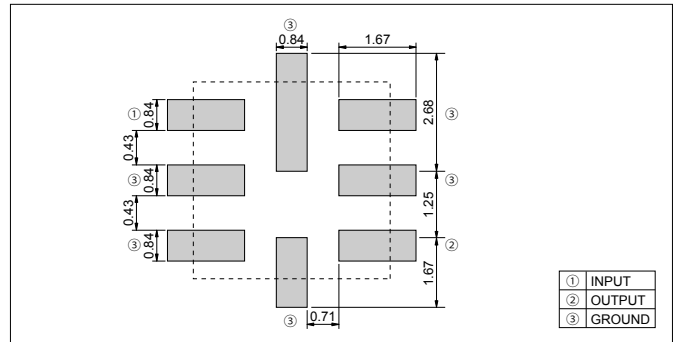

Specifications

Parts No.	Nominal Center Frequency (fn)	Insertion Loss	Pass Band Width (at 3dB)	Stop Band Attenuation						Operating Temperature	Storage Temperature
				10MHz	414MHz	428MHz	434.92MHz	442MHz	550MHz		
PAFC433.92AR00	433.920 MHz	4.0dB max.	Fn±200kHz min.	414MHz	428MHz	432.92MHz	442MHz	550MHz	-40 to 85°C	-40 to 85°C	
				42dB min.	35dB min.	15dB min.	10dB min.	35dB min.			40dB min.

Test Circuit

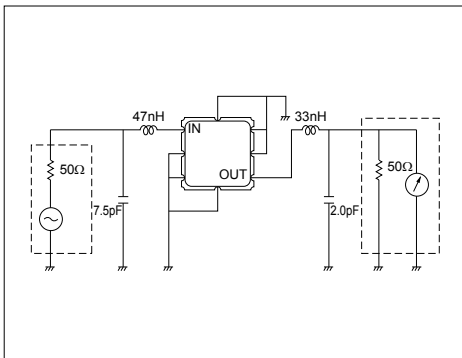

Recommended Temperature IR Reflow

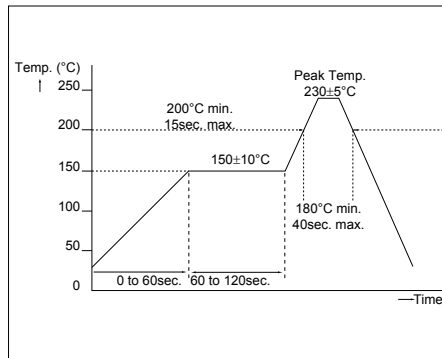

Taping Dimensions

(Unit : mm)

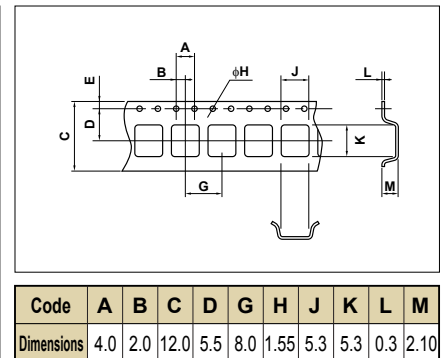

Characteristics

• Pass Band Characteristics

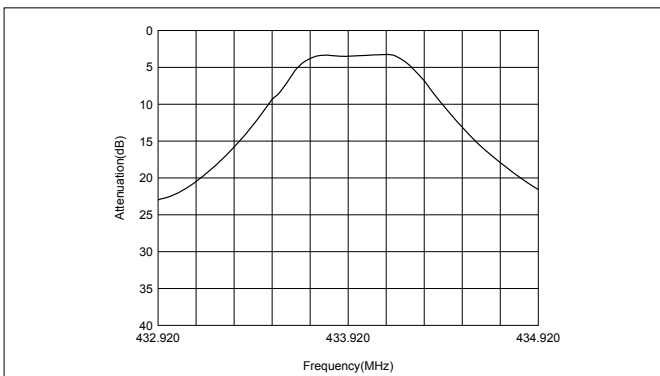

• Spurious Characteristics

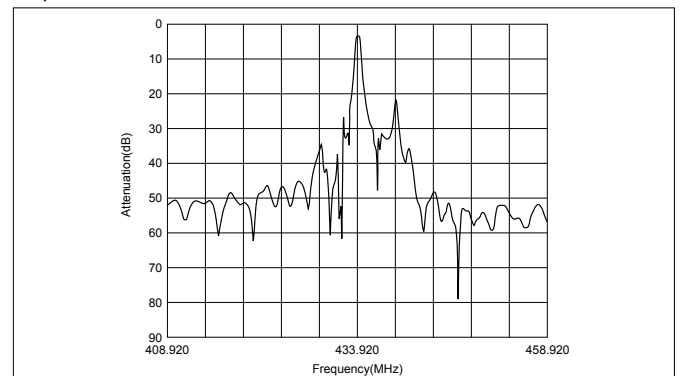



Pb Free

RoHS Compliant

Features

- Miniature size and light weight
- For European remote keyless entry system

Standard Frequency

- 868.3MHz

How to Order

SF 5050 B 868M30 C 600 A00
 ① ② ③ ④ ⑤ ⑥ ⑦

- ① Type of Product (SAW Filter)
- ② Package Size (5.0×5.0mm)
- ③ Sealing Type (Seam Weld Type)
- ④ Nominal Frequency (868.3MHz)
- ⑤ Material (Quartz Crystal)
- ⑥ Pass Bandwidth (600kHz)
- ⑦ Customer Special Model Suffix (STD)

New Part Number	Old Part Number
SF5050B868M30C600A00	MSFB47-868-600K0

Specifications

Item	Unit	Conditions	Specifications
Nominal Frequency (Fo)	MHz	—	868.3
Operating Temperature Range	°C	-45 to +90	—
Storage Temperature Range	°C	-45 to +90	—
Pass Bandwidth	kHz	-3dB	±300 MIN.
Ripple	dB	Fo±300kHz	1.5 MAX.
Insertion Loss	dB	Minimum Loss	4.2 MAX.
Guaranteed Attenuation	dB	-168.3MHz to -38.3MHz	35 MIN.
		-38.3MHz to -18.3MHz	32 MIN.
		-18.3MHz to -3.3MHz	25 MIN.
		+2.7MHz to +6.2MHz	11 MIN.
		+6.2MHz to +14.7MHz	22 MIN.
		+14.7MHz to +31.7MHz	30 MIN.
Terminating Impedance	Ω/pF	—	315// -1.1

Dimensions

(Unit : mm)

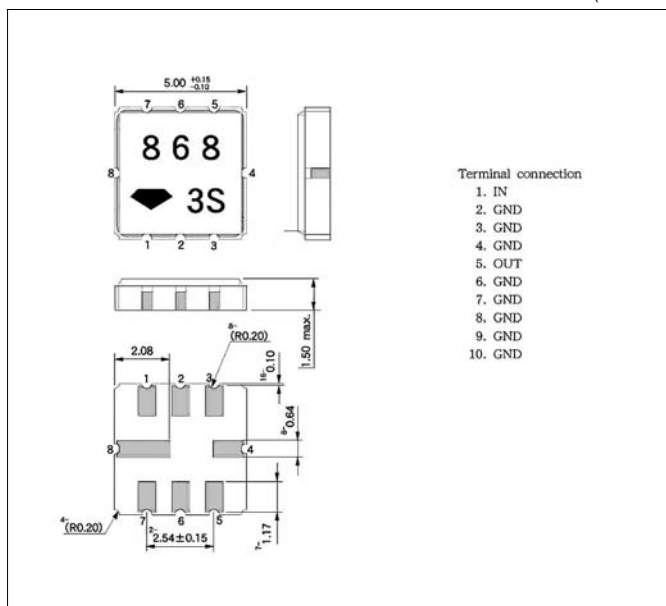

Recommended Land Pattern

(Unit : mm)

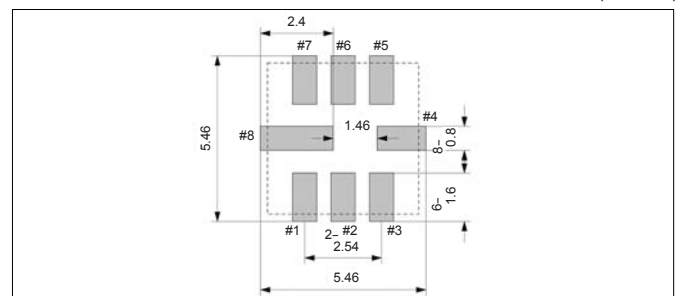

Test Circuit

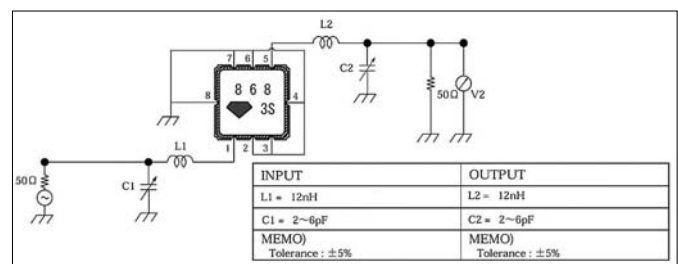



Pb Free

RoHS Compliant

Features

- RF filter for transmitter and receiver
- For low power radio communications
- Miniature size and light weight

Standard Frequency

- 428.00MHz

How to Order

SF 3030 B 428M00 T 04M A02
 ① ② ③ ④ ⑤ ⑥ ⑦

- ① Type of Product (SAW Filter)
- ② Package Size (3.0×3.0mm)
- ③ Sealing Type (Seam Weld Type)
- ④ Nominal Frequency (428.00MHz)
- ⑤ Material (LiTaO₃)
- ⑥ Pass Bandwidth (4MHz)
- ⑦ Customer Special Model Suffix (STD)

New Part Number	Old Part Number
SF3030B428M00T04MA02	TSFB-428-004M2

Specifications

Item	Unit	Conditions	Specifications
Nominal Frequency (Fo)	MHz	—	428.000
Operating Temperature Range	°C	-20 to +85°C	—
Storage Temperature Range	°C	-40 to +85°C	—
Ripple	dB	Fo±2MHz	1.5dB MAX.
Insertion Loss	dB	MAX.	3 MAX.
Guaranteed Attenuation	dB	383 to 389MHz	50 MIN.
Terminating Impedance	Ω	—	50

Dimensions

(Unit : mm)

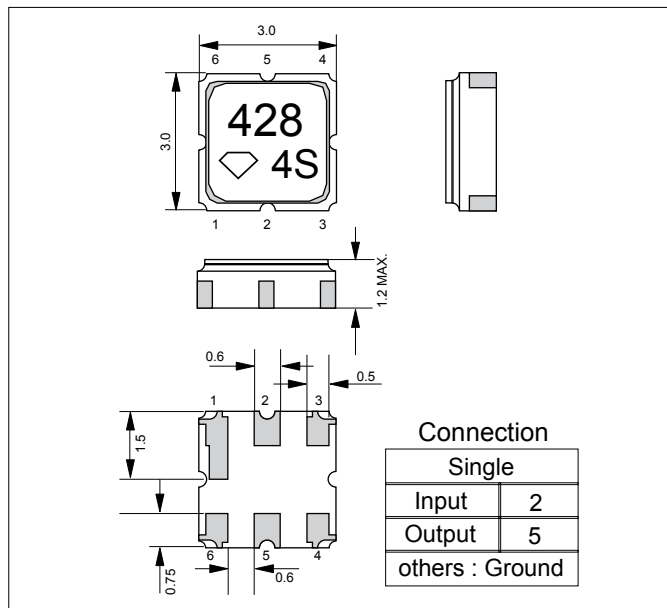

Recommended Land Pattern

(Unit : mm)

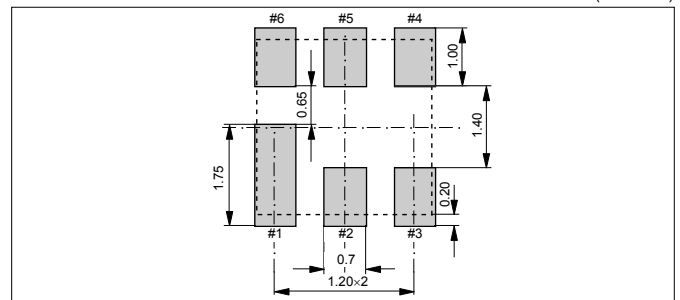

Test Circuit

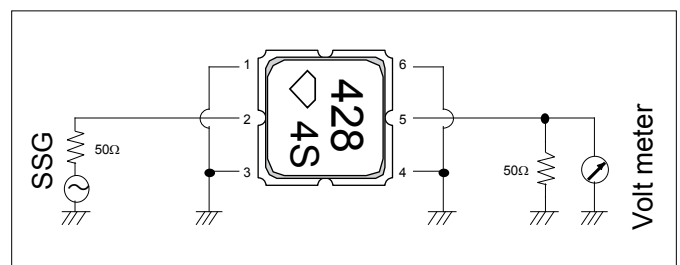



Surface Acoustic Wave (SAW) Filters

400MHz Band SAW Filters for Low Power Radio Communications



SF3535B426M54B800A00/ SF3535B429M55B800A00/ SF7050B469M18B01MA00/ SF3838B426M07C080A00/ SF3838B429M17C080A00/ SF3838B440M20B400A00

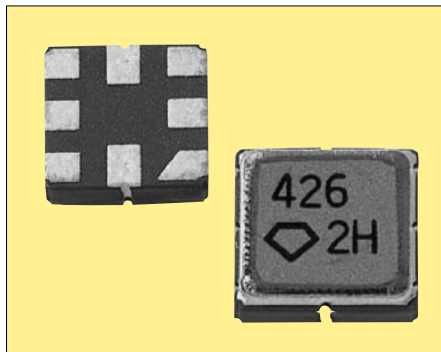

Pb Free

RoHS Compliant

Features

- RF filter for transmitter and receiver
- For low power radio communications
- Miniature size and light weight

Standard Frequency

- 426.54MHz
- 429.55MHz
- 440.2MHz
- 469.1875MHz

How to Order

SF 3535 B 426M54 B 800 A00
 ① ② ③ ④ ⑤ ⑥ ⑦

- ① Type of Product (SAW Filter)
- ② Package Size (3.5×3.5mm)
- ③ Sealing Type (Seam Weld Type)
- ④ Nominal Frequency (426.54MHz)
- ⑤ Material (Li₂B₄O₇)
- ⑥ Pass Bandwidth (800kHz)
- ⑦ Customer Special Model Suffix (STD)

Standard Frequency

Nominal Frequency (MHz)	New Part Number	Old Part Number	Remarks
426.54	SF3535B426M54B800A00	LSFB44-426-800K0	Midle Band Width
	SF3838B426M07C080A00	MSFB19-426-080K0	Ultra Narrow Band Width
429.55	SF3535B429M55B800A00	LSFB44-429-800K0	Midle Band Width
	SF3838B429M17C080A00	MSFB19-429-080K0	Ultra Narrow Band Width
440.2	SF3838B440M20B400A00	LSFB19-440-440K0	—
469.1875	SF7050B469M18B01MA00	LSFB20-469-001M0	—

Specifications (Example)

Item	Unit	Conditions	SF3535B426M54B800A00 Specifications
Nominal Frequency (Fo)	MHz	—	426.54
Operating Temperature Range	°C	-10 to +60	—
Storage Temperature Range	°C	-30 to +70	—
Ripple	dB	Fo±400kHz	0.4* 1.5 MAX.
Insertion Loss	dB	Fo±400kHz	2.8* 3.5 MAX.
Guaranteed Attenuation	dB	(F-21.4)±400kHz	60* 50 MIN.
Terminating Impedance	Ω	—	50 Typical

* : Typ.

Recommended Land Pattern (Unit : mm)

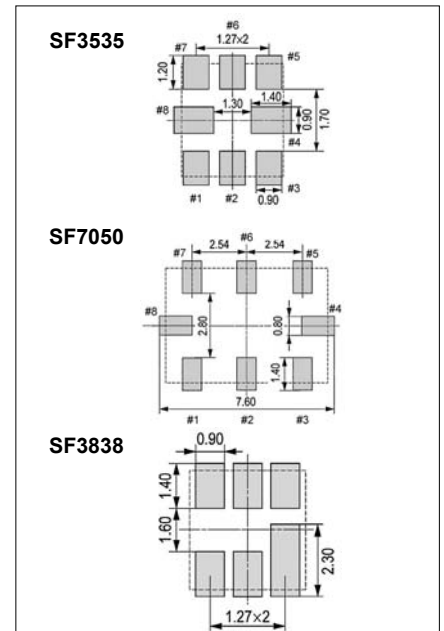

Dimensions

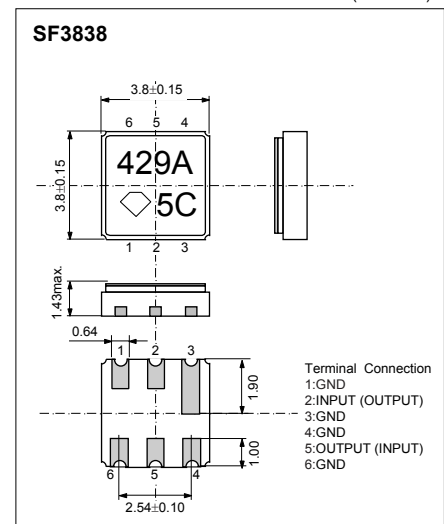
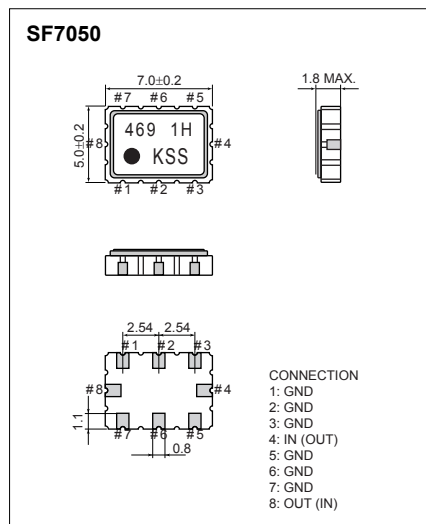
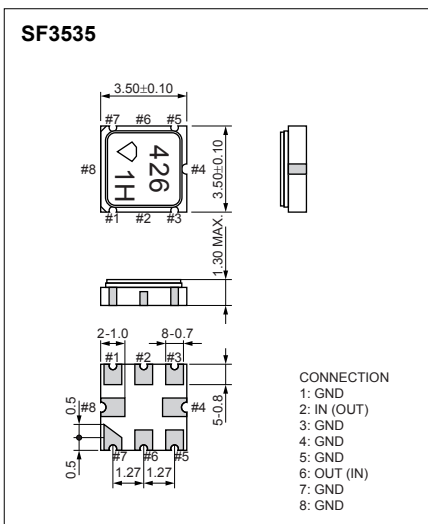



Pb Free

RoHS Compliant

Features

- Small size(3.0x3.0x1.5mm max.)
- Ceramic package type
- Flat pass band characteristics
- Low insertion loss
- Circuit simplification

Standard Frequencies

- PHS

How to Order

PAFA 243 A R 01
① ② ③ ④ ⑤

- ① Series
- ② Center Frequency
- ③ Marking code
- ④ Packaging
- ⑤ Frequency tolerance or Custom spec

Dimensions

(Unit : mm)

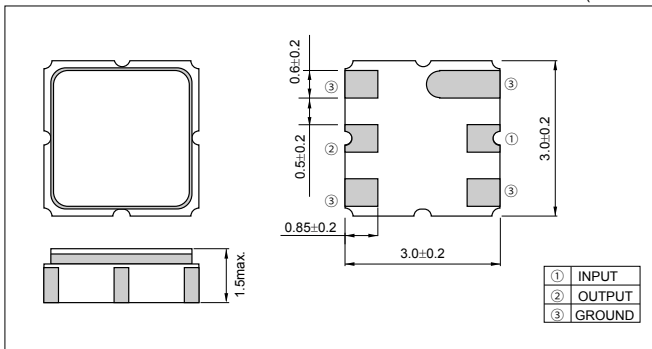

(Unit : mm)

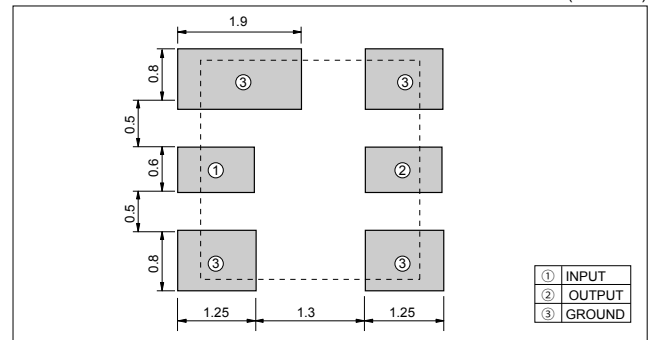

Specifications

Parts No.	Nominal Center Frequency (fn)	Insertion Loss	Pass Band Width (at 3dB)	Stop Band Attenuation			Ripple (fn±110kHz)	Group Delay Time (fn±110kHz)	Operating Temperature	Storage Temperature
				fn±600kHz	fn±1.2MHz	fn±fa MHz(*)				
PAFA243AR01	243.95MHz	≤4.5dB	±130kHz min.	30dB min.	40dB min.	60dB min.	1.5dB max.	1.2μs max.	-10 to 60 °C	-20 to 80 °C

Test Circuit

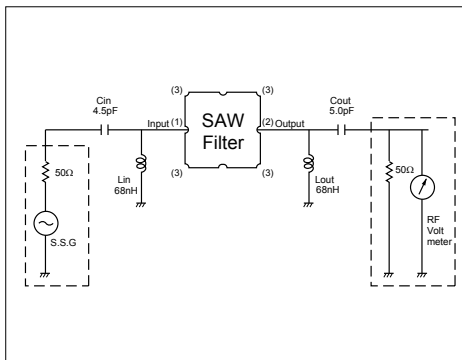

Recommended Temperature IR Reflow

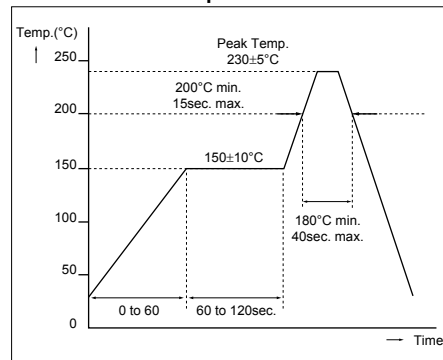

Packaging

(Unit : mm)

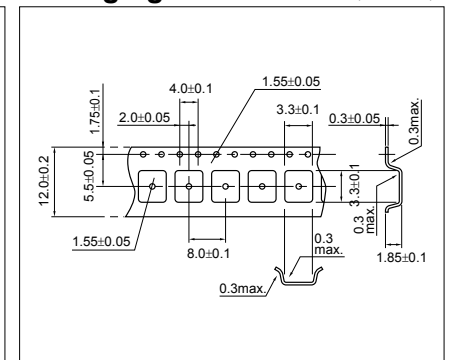

Characteristics

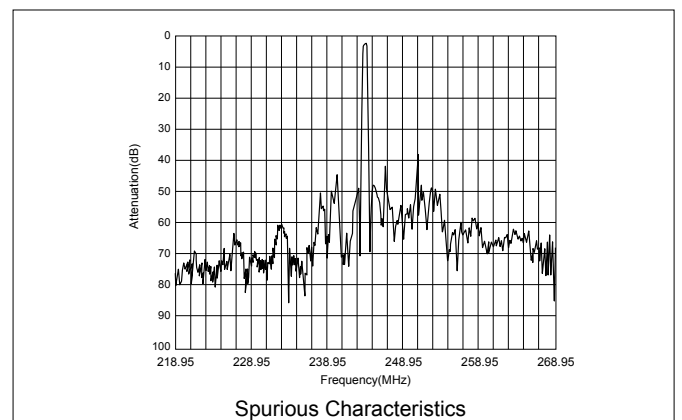
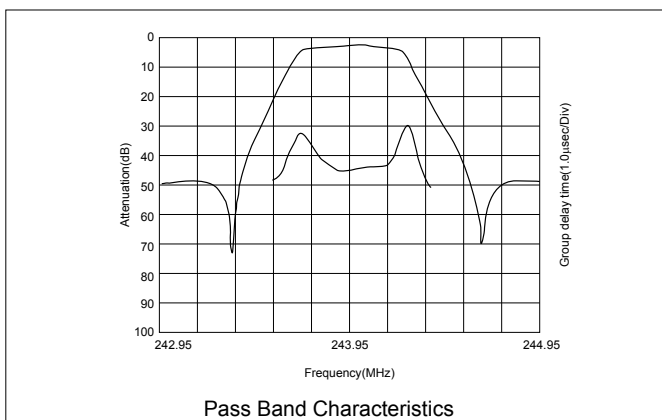



Pb Free

RoHS Compliant

Features

- IF filter for PHS
- Miniature size and light weight

Standard Frequency

- 243.95MHz

How to Order

SF 3535 B 243M95 B 220 A00
 ① ② ③ ④ ⑤ ⑥ ⑦

- ① Type of Product (SAW Filter)
- ② Package Size (3.5×3.5mm)
- ③ Sealing Type (Seam Weld Type)
- ④ Nominal Frequency (243.95MHz)
- ⑤ Material (Li₂B₄O₇)
- ⑥ Pass Bandwidth (220kHz)
- ⑦ Customer Special Model Suffix (STD)

New Part Number	Old Part Number
SF5353B243M95B220A00	LSFB44-243-220K0

Specifications

Item	Unit	Conditions	Specifications	
Nominal Frequency (Fo)	MHz	—	243.95	
Operating Temperature Range	°C	-10 to +60	—	
Storage Temperature Range	°C	-35 to +85	—	
Ripple	dB	Fo±110kHz	0.5* 1.5 MAX.	
Insertion Loss	dB	Minimum Loss	2.7* 5 MAX.	
Guaranteed Attenuation	dB	Fo±0.6MHz	-0.6/40*	25 MIN.
			+0.6/35*	
		Fo±1.2MHz	-1.2/45*	40 MIN.
			+1.2/42*	
Group Delay Deviation	µsec	Fo±110kHz	70* 60 MIN. 0.4* 1.2 MAX.	

* : Typ.

Dimensions

(Unit : mm)

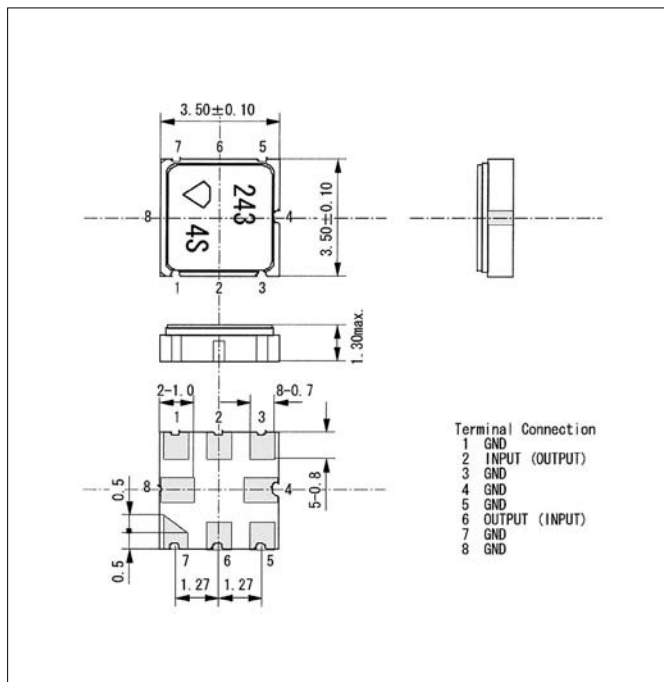

Recommended Land Pattern

(Unit : mm)

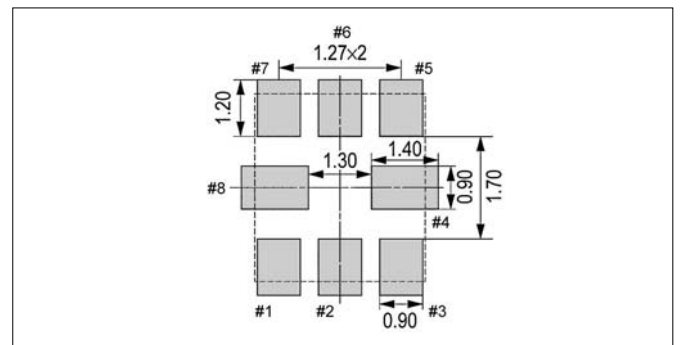

Test Circuit

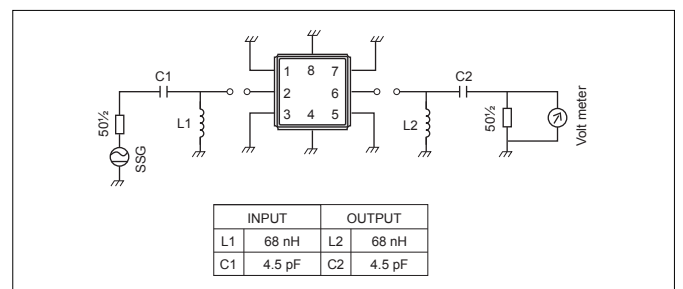

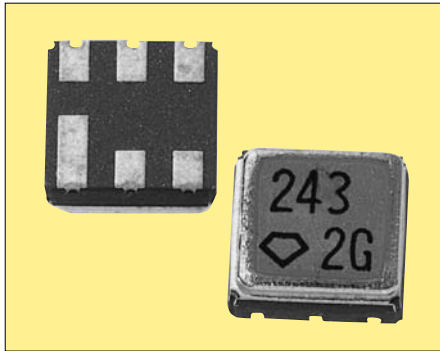

Pb Free

RoHS Compliant

Features

- IF filter for PHS
- Miniature size and light weight

Standard Frequency

- 243.95MHz
- 248.45MHz

How to Order

SF 3838 B 243M95 B 220 A00
 ① ② ③ ④ ⑤ ⑥ ⑦

- ① Type of Product (SAW Filter)
- ② Package Size (3.8×3.8mm)
- ③ Sealing Type (Seam Weld Type)
- ④ Nominal Frequency (243.95MHz)
- ⑤ Material (Li₂B₄O₇)
- ⑥ Pass Bandwidth (220kHz)
- ⑦ Customer Special Model Suffix (STD)

New Part Number	Old Part Number
SF3838B243M95B220A00	LSFB19-243-220K0
SF3838B248M45B220A00	LSFB19-248-220K0

Specifications

Item	Unit	Conditions	SF3838B243M95B220A00 Specifications		SF3838B248M45B220K0 Specifications	
Nominal Frequency (Fo)	MHz	—	243.95		248.45	
Operating Temperature Range	°C	-10 to +60	—		—	
Storage Temperature Range	°C	-35 to +85	—		—	
Ripple	dB	Fo±110kHz	0.5*	1.5 MAX.	0.5*	1.5 MAX.
Insertion Loss	dB	Minimum Loss	2.6*	5 MAX.	2.6*	5 MAX.
Guaranteed Attenuation	dB	Fo±0.6MHz	-0.6/52*	25 MIN.	-0.6/55*	25 MIN.
			+0.6/34*		+0.6/36*	
		Fo±1.2MHz	-1.2/47*	40 MIN.	-1.2/55*	35 MIN.
	+1.2/43*	+1.2/43*				
		Fo-21.6MHz	70*	60 MIN.	65*	60 MIN.
Group Delay Deviation	μsec	Fo±110kHz	0.5*	1.2 MAX.	0.3*	1.2 MAX.

* : Typ.

* : Typ.

Dimensions

(Unit : mm)

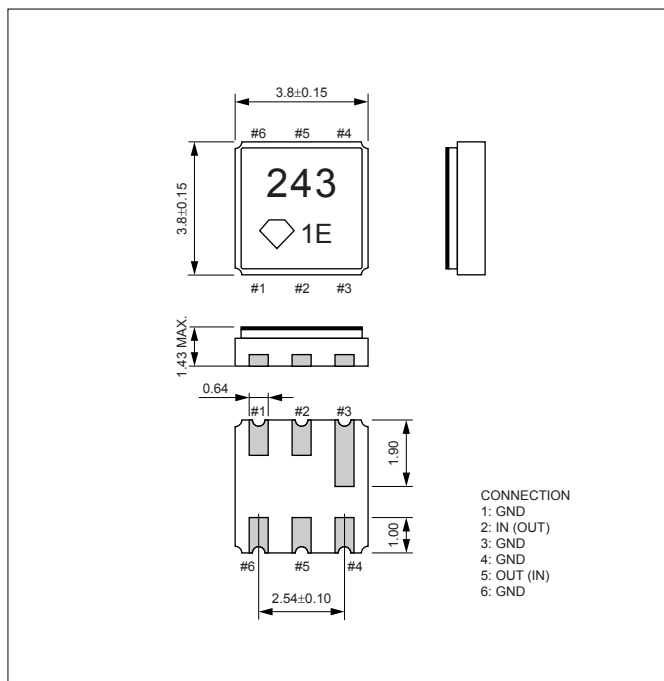

Recommended Land Pattern

(Unit : mm)

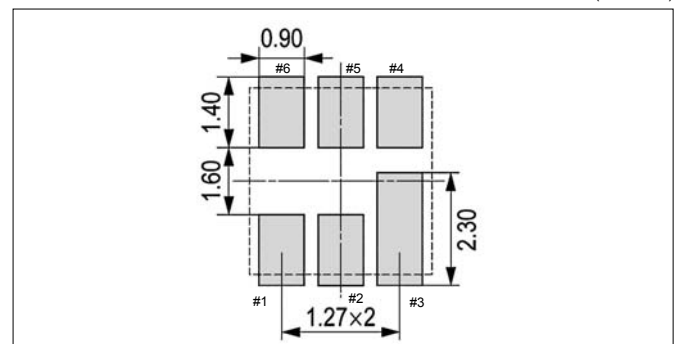

Test Circuit

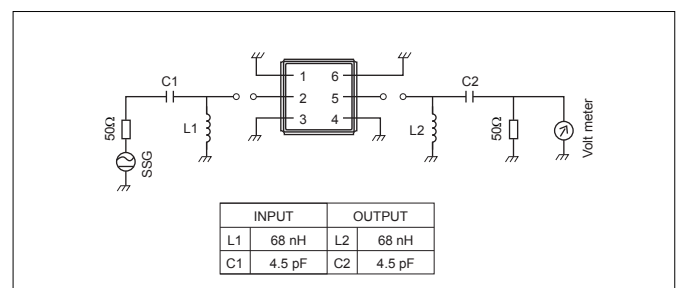



Pb Free

RoHS Compliant

Features

- Small and low profile
- Ceramic package type
- Flat pass band characteristics
- Low insertion loss
- Circuit simplification

Application

- PHS

How to Order

PAFC 243 B
① ② ③

- ① Series
- ② Center Frequency
- ③ Type

Dimensions

(Unit : mm)

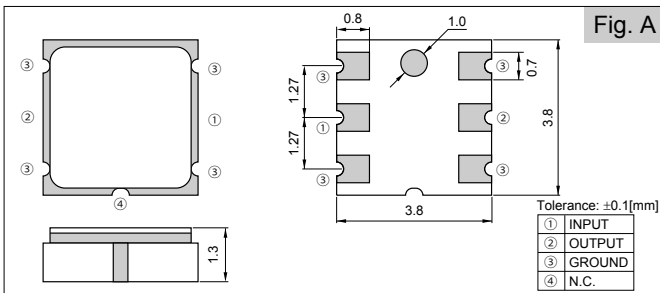

(Unit : mm)

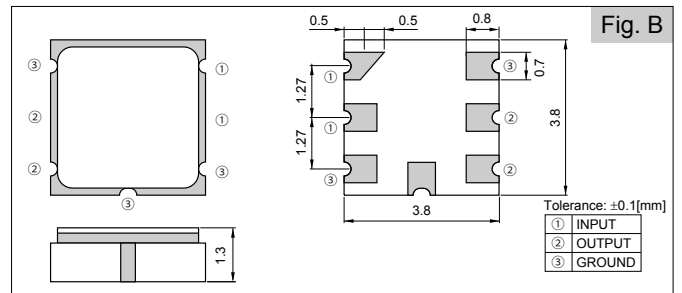

Test Circuit

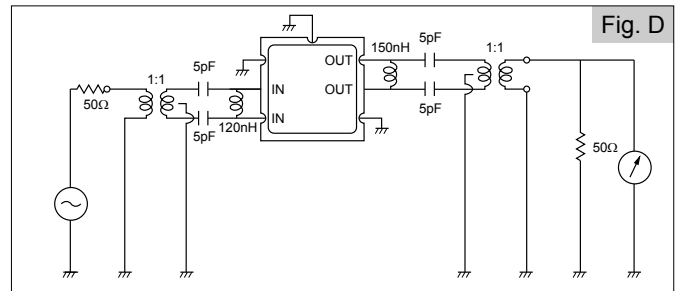
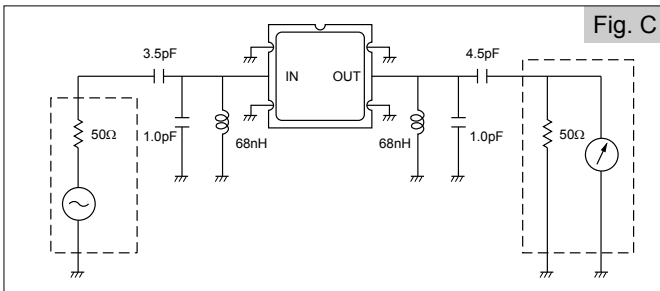

Specifications

Parts No.	Nominal Center Frequency (fn)	Insertion Loss	Pass Band Width (at 3dB)	Stop Band Attenuation			Ripple (fn±110kHz)	Group Delay Time (fn±110kHz)	Operating Temperature	Storage Temperature	Dimensions	Test Circuit	Recommended Land Pattern	Taping Dimensions
				fn±600kHz	fn±1.2MHz	fn±fa MHz(±)								
PAFC243B	243.95MHz	4.0dB max.	±130kHz min.	30dB min.	40dB min.	60dB min.	1.5dB max.	1.2μs max.	-10 to 60°C	-20 to 80°C	Fig. A	Fig. C	Fig. E	Fig. G
PAFC248C	248.45MHz	4.5dB max.	±130kHz min.	30dB min.	35dB min.	60dB min.	1.5dB max.	1.2μs max.	-10 to 60°C	-20 to 80°C	Fig. B	Fig. D	Fig. F	Fig. G

* Note PAFC248C : fa=21.5MHz
PAFC243B : fa=21.6MHz

Recommended Land Pattern

(Unit : mm)

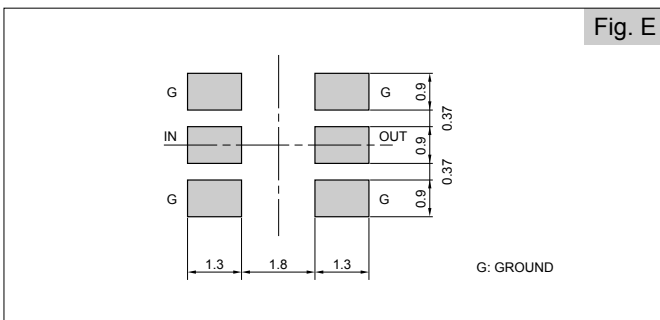

(Unit : mm)

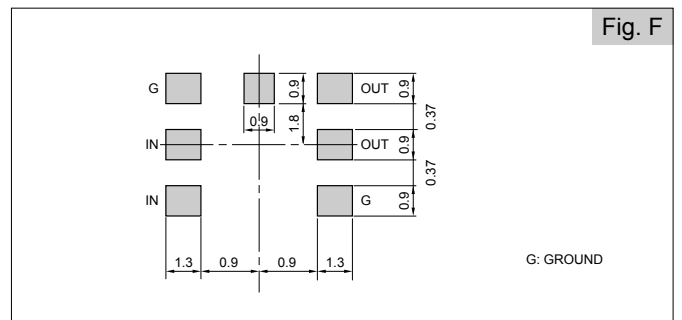

Taping Dimensions

(Unit : mm)

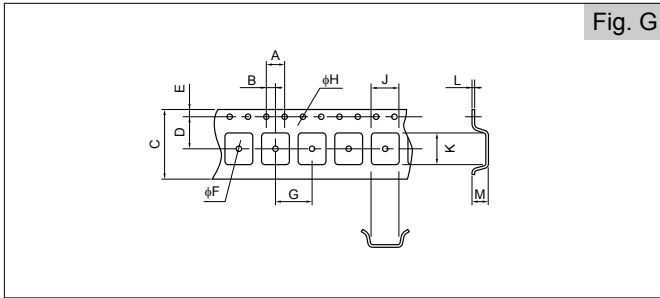
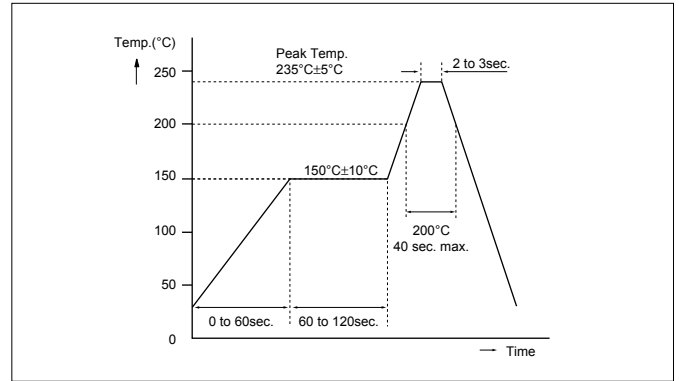

Fig. G

Code	A	B	C	D	E	F	G	H	J	K	L	M
Dimension	4.0	2.0	12.0	5.5	1.75	1.55	8.0	1.55	4.3	4.3	0.3	2.05

Recommended Temperature Profile IR Reflow



Characteristics

PAFC248C (Pass Band Characteristics)

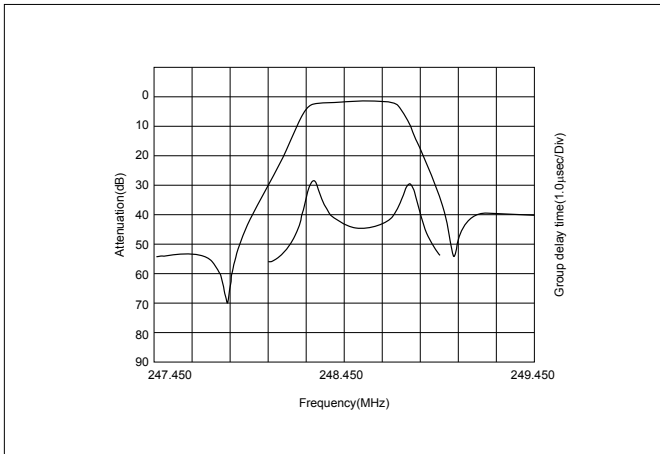

PAFC248C (Spurious Characteristics)

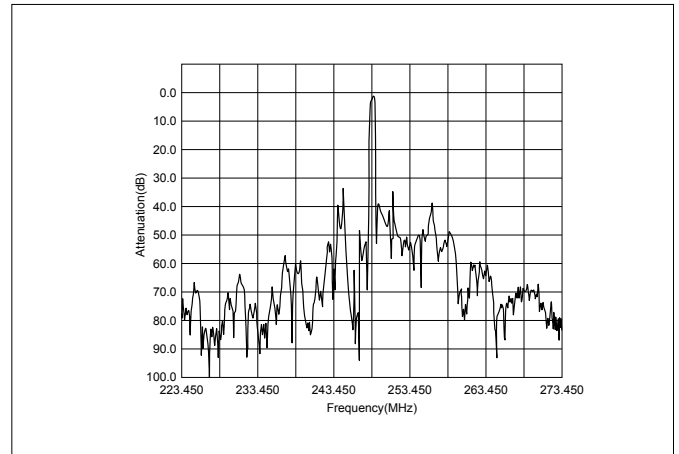

PAFC243B (Pass Band Characteristics)

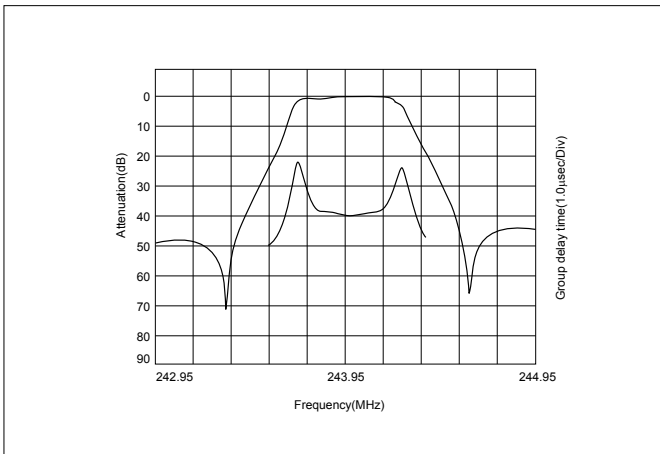

PAFC243B (Spurious Characteristics)

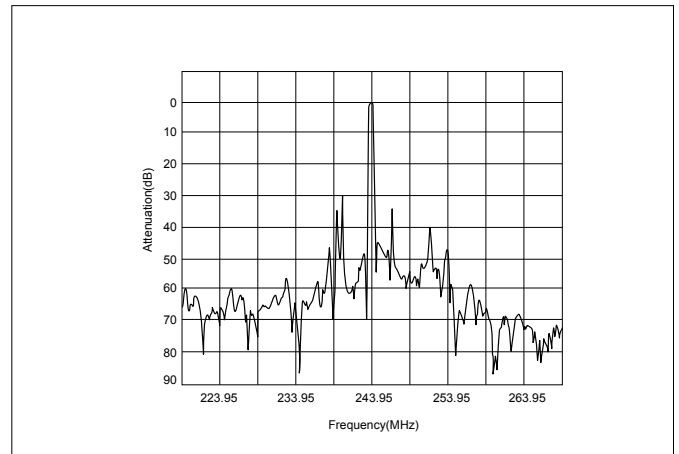

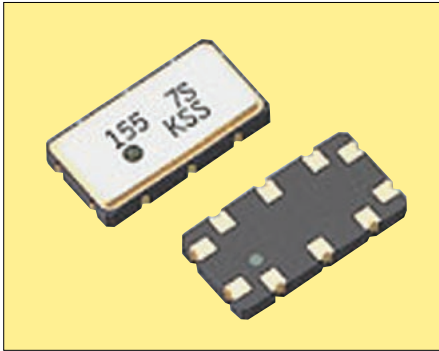

Pb Free

RoHS Compliant

Features

- For Fiber optic communications
- Miniature size and light weight

Standard Frequency

- 155.520MHz
- 622.080MHz

How to Order

SF 9148 B 155M52 C 155 A00
 ① ② ③ ④ ⑤ ⑥ ⑦

- ① Type of Product (SAW Filter)
- ② Package Size (9.1×4.8mm)
- ③ Sealing Type (Seam Weld Type)
- ④ Nominal Frequency (155.520MHz)
- ⑤ Material (Quartz Crystal)
- ⑥ Pass Bandwidth (155kHz)
- ⑦ Customer Special Model Suffix (STD)

New Part Number	Old Part Number
SF9148B155M52C155A00	MSFB22-155-155K0
SF9148B622M08C622A00	MSFB22-622-622K0

Specifications

Type		SF9148B155M52C155A00		SF9148B622M08C622A00	
Item	Unit	Conditions	Specifications	Conditions	Specifications
Nominal Frequency	MHz	—	155.52	—	622.08
Operating Temperature Range	°C	-20 to +75	—	-20 to +75	—
Storage Temperature Range	°C	-40 to +85	—	-40 to +85	—
Q Value		600 < Q < 1000 910*		600 < Q < 1000 830*	
Insertion Loss	dB	Minimum Loss	8 MAX.*	Minimum Loss	7.2 MAX.*
Guaranteed Attenuation	dB	DC to 152MHz	30 MIN.	DC to 606MHz	30 MIN.
		159 to 312MHz	30 MIN.	699 to 1245MHz	25 MIN.
Group Delay Deviation	Ω	—	50	—	50

* : Typ.

* : Typ.

Dimensions

(Unit : mm)

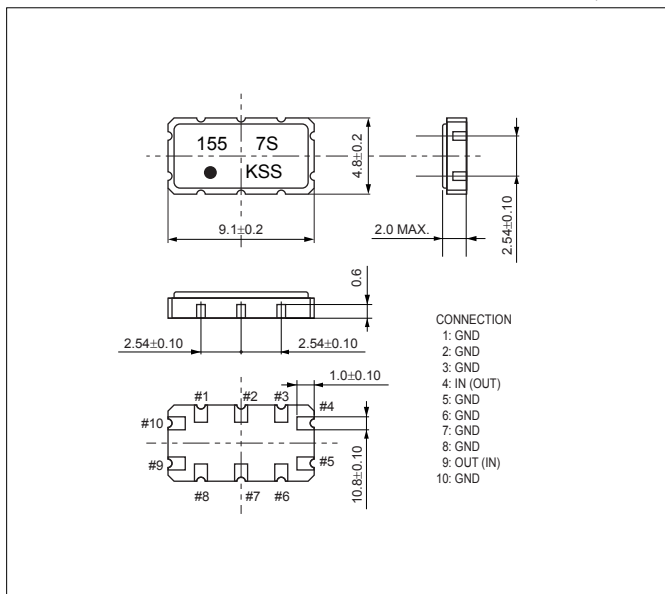

Recommended Land Pattern

(Unit : mm)

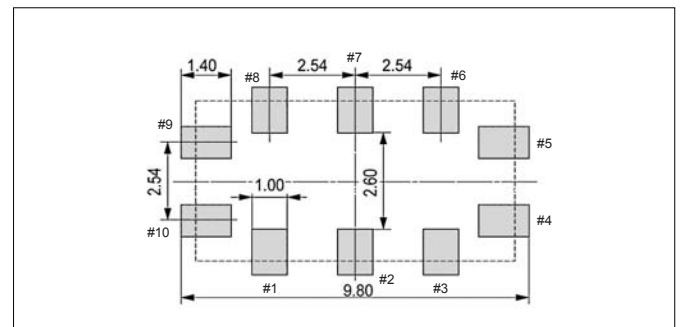

Test Circuit

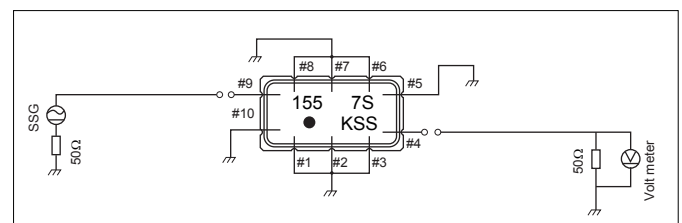

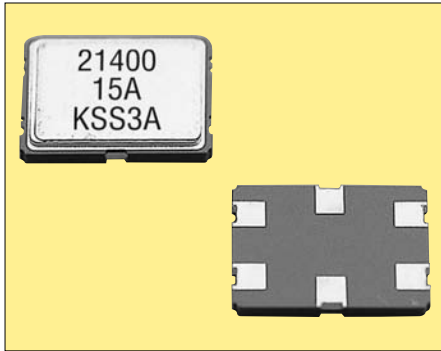

Pb Free

RoHS Compliant

Features

- Compact and low profile (H=1.3mm)
- Excellent vibration resistance and shock resistance
- Reflow soldering

Applications

- Mobile communication

How to Order

MF 7050 A 021400 F 15.0 A 0
 ① ② ③ ④ ⑤ ⑥ ⑦ ⑧

- ① Type of Product (Monolithic Crystal Filter)
- ② Package Size (7.0×5.0mm)
- ③ Number of Poles (2-Pole)
- ④ Nominal Freq. (21.400MHz)
- ⑤ Vibration Mode (Fundamental Mode)
- ⑥ Pass Bandwidth (15.0kHz(±7.5kHz))
- ⑦ Specification 1 (FP2 Package)
- ⑧ Specification 2 (Version 0)

Specifications

Type (Current type)	Number of Poles	Pass Bandwidth		Ripple	Insertion Attenuation	Stop Bandwidth		Terminating Impedance	Operating Temp. Range
		dB	kHz min.	dB max.	dB max.	dB	kHz max.	Ω/pF	°C
MF7050A021400F15.0A0 (MXF21.4-15A-FP2)	2	3	±7.5	0.5	1.5	18	±25	1.5k//2.5	-20 to +70
MF7050A021700F08.0A0 (MXF21.7-8A-FP2)	2	3	±3.5	1	2	16	±12.5	1.5k//6	-20 to +70
MF7050A045000F15.0A0 (MXF45-15AF-FP2)	2	3	±7.5	1	2.5	14	±25	550//3	-20 to +70
MF7050A045000F30.0A0 (MXF45-30AF-FP2)	2	3	±15	1	2	15	±50	1.2k//1.5	-20 to +70
MF7050A055000F26.0A0 (MXF55-26AF-FP2)	2	3	±13	1	3	27	±100	750//2.7	-20 to +70

Dimensions

(Unit : mm)

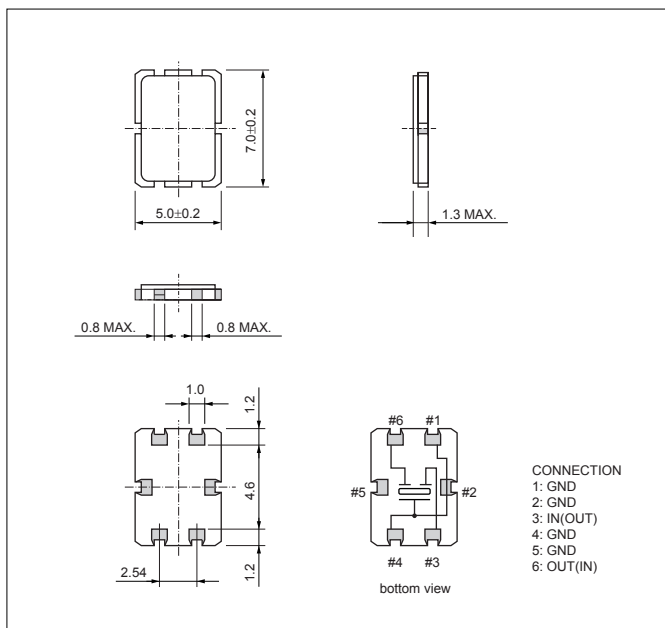

Recommended Land Pattern

(Unit : mm)

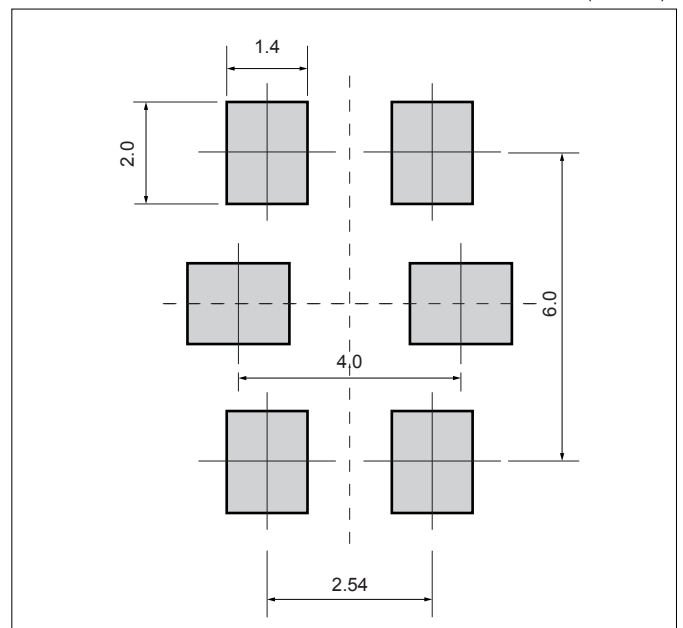

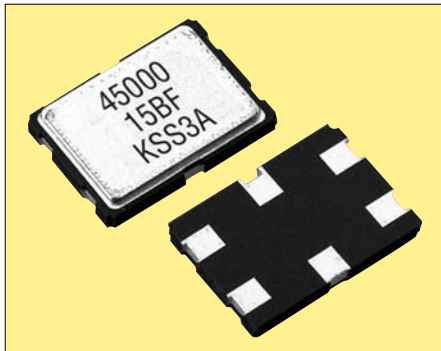

Pb Free

RoHS Compliant

Features

- Compact size (7x5mm, 4-Pole)
- Excellent vibration resistance and shock resistance
- Reflow soldering

Applications

- Mobile communication

How to Order

MF 7050 B 045000 F 07.5 B 0
 ① ② ③ ④ ⑤ ⑥ ⑦ ⑧

- ① Type of Product (Monolithic Crystal Filter)
- ② Package Size (7.0×5.0mm)
- ③ Number of Poles (4-Pole)
- ④ Nominal Freq. (45.000MHz)
- ⑤ Vibration Mode (Fundamental Mode)
- ⑥ Pass Bandwidth (7.5kHz(±3.75kHz))
- ⑦ Specification 1 (FP4 Package)
- ⑧ Specification 2 (Version 0)

Specifications

Type (Current type)	Number of Poles	Pass Bandwidth		Ripple	Insertion Attenuation	Stop Bandwidth		Terminating Impedance	Operating Temp. Range
		dB	kHz min.	dB max.	dB max.	dB	kHz max.	Ω /pF	°C
MF7050B045000F07.5B0 (MXF45-7.5BF-FP4)	4	3	±3.75	1	4	30	±15	500//4.5 (Cc=13pF)	-20 to +70
MF7050B045000F15.0B0 (MXF45-15BF-FP4)	4	3	±7.5	1.5	2	30	±25	600//2.3 (Cc=7.5pF)	-20 to +70
MF7050B045000F30.0B0 (MXF45-30BF-FP4)	4	3	±15	1	3	30	±40	1.2k//1.0 (Cc=2.5pF)	-20 to +70

Dimensions

(Unit: mm)

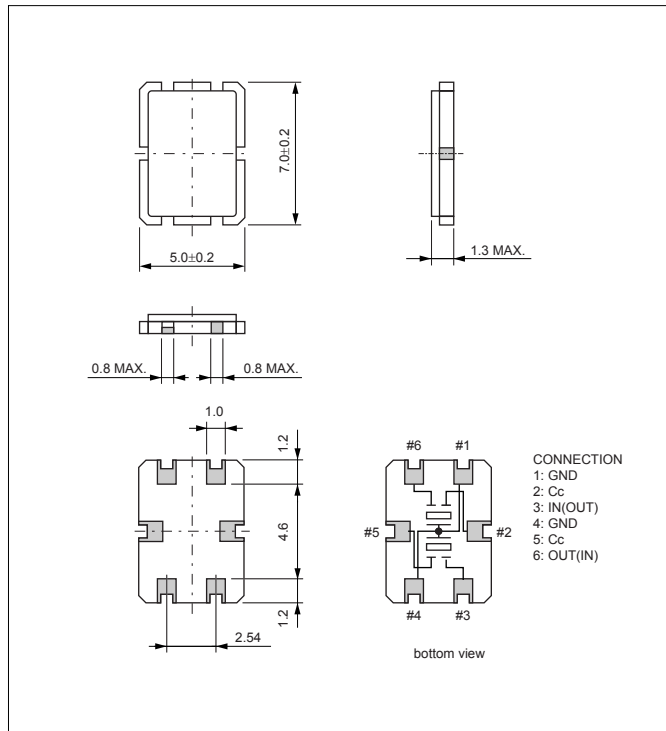

Electrical Characteristics

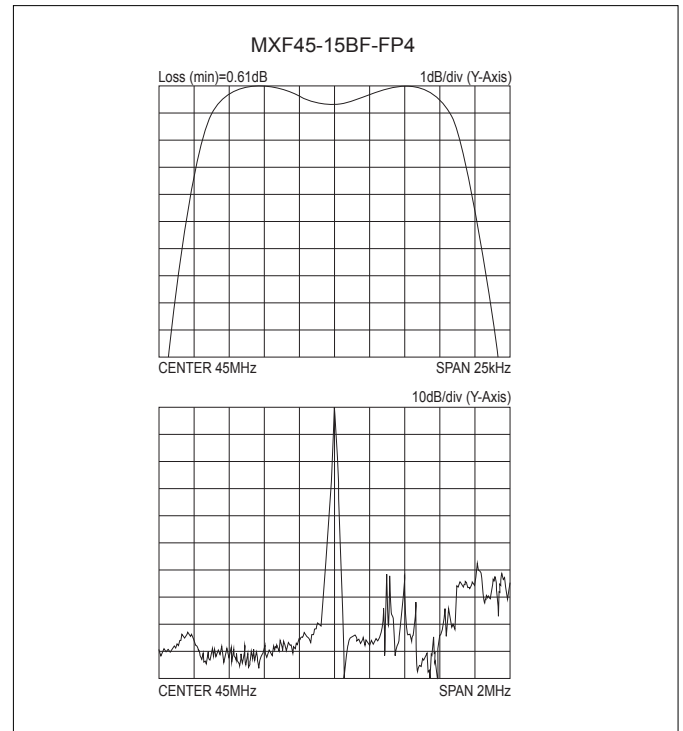

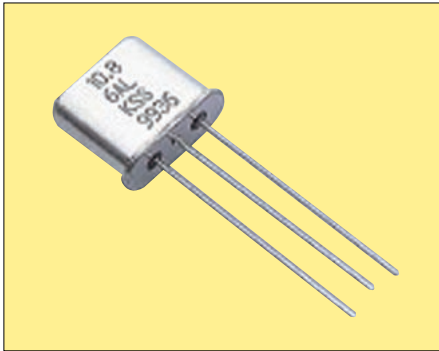

Pb Free

RoHS Compliant

Features

- Compact and light weight
- Excellent vibration resistance and shock resistance
- Stable temperature characteristics

Applications

- Car audio

How to Order

MF 49UZ A 010700 F 06.0 N 0
 ① ② ③ ④ ⑤ ⑥ ⑦ ⑧

- ① Type of Product (Monolithic Crystal Filter)
- ② Package Size (49UZ:HC-49/U-11 (H=11.5mm)) (49UL:HC-49/U-9 (H=9.5mm))
- ③ Number of Poles (2-Pole)
- ④ Nominal Freq. (10.700MHz)
- ⑤ Vibration Mode (Fundamental Mode)
- ⑥ Pass Bandwidth (6.0kHz(±3.0kHz))
- ⑦ Specification 1 (Not Cutoff Lead)
- ⑧ Specification 2 (Version 0)

Specifications

Type (Current type)	Number of Poles	Pass Bandwidth		Ripple	Insertion Attenuation	Stop Bandwidth		Terminating Impedance	Operating Temp. Range
		dB	kHz	dB max.	dB max.	dB	kHz max.	Ω/pF	°C
MF49UZA017000F06.0N0 (MXF107-6A)	2	3	±(2.5~3.5)	1	1.5	30	55	1.5k//3	-40 to +85
MF49ULA017000F06.0N0 (MXF10.7-6AL)	2	3	±(2.5~3.5)	1	3	30	55	1.5k//3	-40 to +85
MF49UZA017000F07.5N0 (MXF10.7-7.5A)	2	3	±3.75 min.	0.5	1.5	20	±18	1.8k//5	-40 to +85
MF49ULA017000F07.5N0 (MXF10.7-7.5AL)	2	3	±3.75 min.	0.5	3	20	±18	1.8k//5	-40 to +85
MF49UZA018000F06.0N0 (MXF10.8-6A)	2	3	±(2.5~3.5)	1	1.5	30	55	1.5k//3	-40 to +85
MF49ULA018000F06.0N0 (MXF10.8-6AL)	2	3	±(2.5~3.5)	1	3	30	55	1.5k//3	-40 to +85
MF49ULA018000F16.0N0 (MXF10.8-16AL)	2	3	±(7.5~8.5)	1	3	20	55	2.2k//2.5	-40 to +85

Dimensions

(Unit : mm)

(Unit : mm)

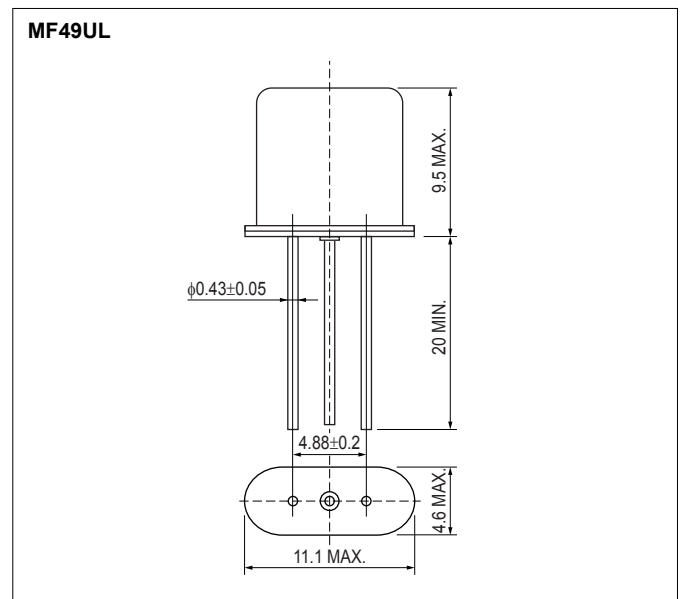
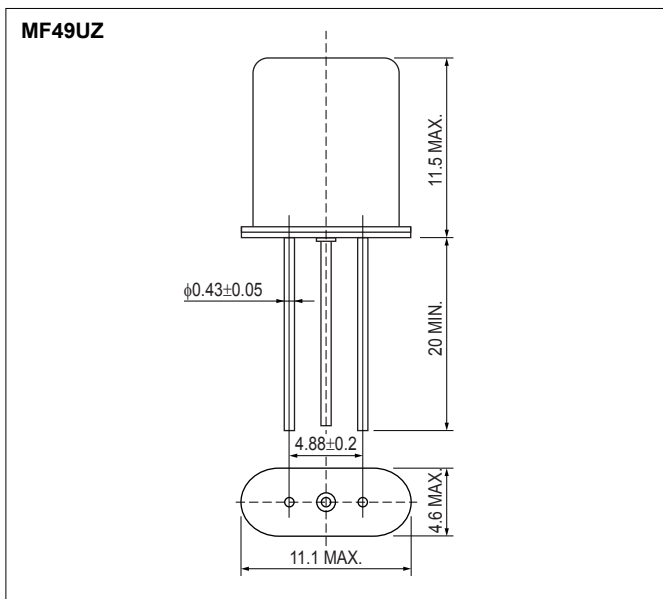



Characteristic diagram and terms of crystal filters

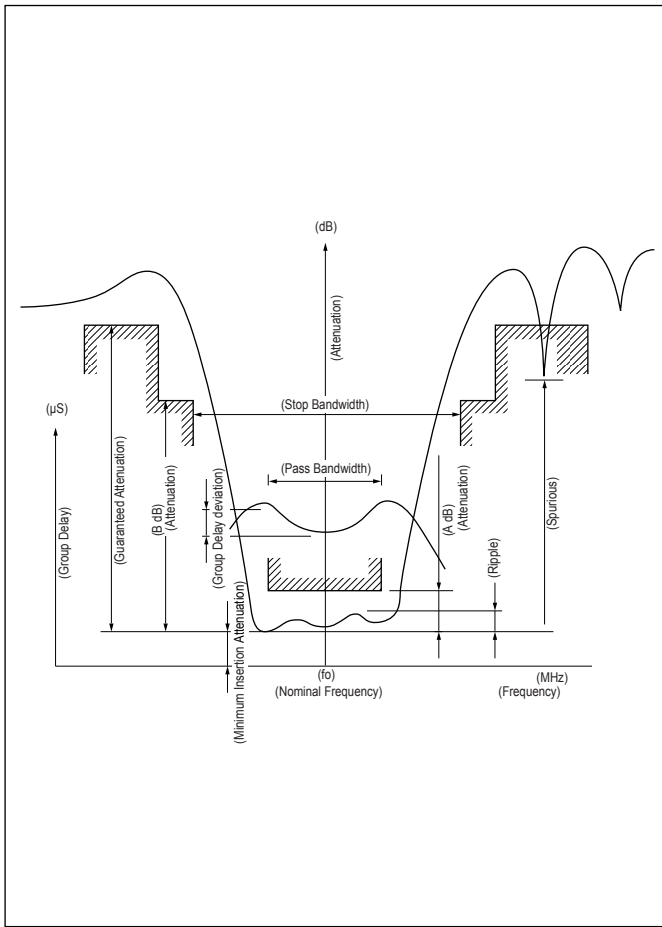

■Nominal Frequency

This is the nominal value of the center frequency (f_0) and is used as the reference frequency of related standards.

■Pass Bandwidth

This is the frequency interval in which the relative attenuation (the attenuation from the minimum insertion attenuation) is equal to the specified value "A dB" (Usually 3dB).

■Insertion Attenuation (Insertion Loss)

This is the difference of attenuation when a filter is and isn't inserted. The minimum insertion attenuation is the minimum value of insertion attenuation and becomes as the reference level of attenuation characteristics specification.

■Ripple

This is the maximum value of the difference between the peak value of attenuation in the pass band and the minimum insertion loss.

■Stop Bandwidth

This is the frequency interval in which the relative attenuation is equal to the specified value "B dB".

■Guaranteed Attenuation

This is the relative attenuation guaranteed in the specified range within attenuation band scope.

■Spurious Response

This is the value of relative attenuation generated by the secondary vibration in the specified range within attenuation band scope.

■Group Delay Deviation

This is the difference between the maximum and the minimum value of the group delay in the specified range of the pass band.

■Terminating Impedance

This is the impedance value terminated to the input and the output side of filter and is indicated by the resistance portion and the parallel capacity portion including the floating capacity.

Tape & Reel Specifications

SAW FILTERS / MCFs

		SAW FILTERS			
		SF14	SF16	PAFA	PAFC243B
T A P E	A	2.0±0.05	2.0±0.05	2.0±0.05	2.0±0.05
	B	4.0±0.1	4.0±0.1	4.0±0.1	4.0±0.1
	C	φ1.5±0.1	φ1.5±0.1	φ1.5+0.1/-0	φ1.5+0.1/-0
	D	4.0±0.1	4.0±0.1	8.0±0.1	8.0±0.1
	E	3.5±0.05	3.5±0.05	5.5±0.05	5.5±0.05
	F	1.75±0.1	1.75±0.1	1.75±0.1	1.75±0.1
	G	8.0±0.2	8.0±0.2	12.0±0.2	12.0±0.2
	H	φ0.5±0.05	φ1.1±0.1	φ1.55±0.1	φ1.55±0.1
	J	1.7±0.1	1.9±0.1	3.3±0.1	4.3±0.1
	L	1.4±0.1	1.85±0.1	3.3±0.1	4.3±0.1
	N	0.8±0.1	0.95±0.1	1.85±0.1	2.05±0.1
L I N E R	P	φ178±2	φ178±2	φ255±2	φ255±2
	Q	φ60±2	φ60±2	φ100±2	φ100±2
	R	φ13±0.2	φ13±0.2	φ13±0.2	φ13±0.2
	S	φ21±0.8	φ21±0.8	φ21±0.8	φ21±0.8
	U	2±0.5	2±0.5	2±0.5	2±0.5
	W	9.5±1	9.5±1	13.5±1	13.5±1
Qty		3000	3000	2000	2000

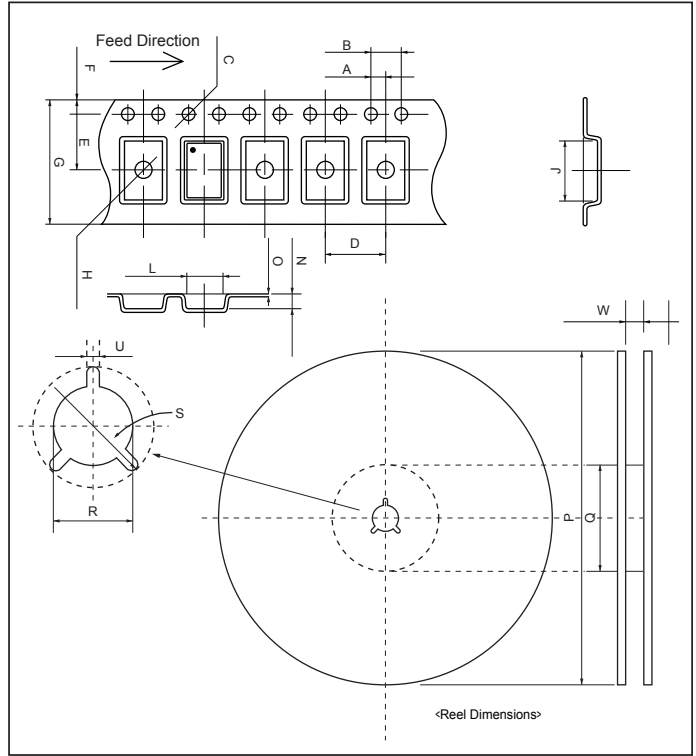

		SAW FILTERS								MCF
		PAFC433.92A	SF5032	SF9148	SF3838	SF7050	SF3535	SF3030	SF6035	MF7050
T A P E	A	2.0±0.05	2.0±0.10	2.0±0.10	2.0±0.05	2.0±0.10	2.0±0.10	2.0±0.05	2.0±0.1	2.0±0.1
	B	4.0±0.1	4.0±0.1	4.0±0.1	4.0±0.1	4.0±0.1	4.0±0.1	4.0±0.1	4.0±0.1	4.0±0.1
	C	φ1.5+0.1/-0	φ1.55±0.05	φ1.55±0.05	φ1.55±0.05	φ1.55±0.05	φ1.55±0.05	φ1.5+0.1/-0	φ1.55±0.05	φ1.55±0.05
	D	8.0±0.1	8.0±0.1	8.0±0.1	8.0±0.1	8.0±0.1	8.0±0.1	4.0±0.1	8.0±0.1	8.0±0.1
	E	5.5±0.05	5.5±0.1	7.5±0.1	5.5±0.05	7.5±0.1	5.5±0.05	5.5±0.05	7.5±0.1	7.5±0.1
	F	1.75±0.1	1.75±0.1	1.75±0.1	1.75±0.1	1.75±0.1	1.75±0.1	1.75±0.1	1.75±0.1	1.75±0.1
	G	12.0±0.3	12.0±0.3	16.0±0.3	12.0±0.15	16.0±0.3	12.0±0.2	12.0±0.2	16.0±0.3	16.0±0.3
	H	φ1.55±0.1	φ1.5+0.05-0	φ1.55±0.05	φ1.55±0.05	φ1.55±0.05	φ1.55±0.05	1.7±0.1	1.55±0.05	φ1.55±0.05
	J	5.3±0.1	5.25±0.1	9.4±0.1	4.2±0.1	7.6±0.1	3.95±0.2	3.25±0.1	6.35±0.1	7.5±0.1
	L	5.3±0.1	3.45±0.1	5.1±0.1	4.2±0.1	5.6±0.1	3.95±0.2	3.25±0.1	3.85±0.1	5.5±0.1
	N	2.1±0.1	1.5+0.1/-0	2.0±0.1	1.8±0.1	1.94±0.1	1.35±0.1	1.35±0.1	1.8±0.1	1.8±0.1
O	0.3±0.05	0.3±0.1	0.3±0.05	0.3±0.05	0.3±0.05	0.2±0.05	0.25±0.05	3.0±0.05	0.3±0.05	
L I N E R	P	φ255±2	φ330±1	φ330±1	φ178±2	φ330±1	φ178±2	φ178±2	φ330±2	φ178±2
	Q	φ100±2	φ100±1	φ100±1	φ80±1	φ100±1	φ80±1	φ80±1	φ100±1	φ80±2
	R	φ13±0.2	φ13±0.3	φ13±0.3	φ13±0.5	φ13±0.3	φ13±0.5	φ13±0.5	φ13±0.3	φ13±0.5
	S	φ21±0.8	φ21±0.5	φ21±0.5	φ21±0.5	φ21±0.5	φ21±0.5	φ21±0.5	φ21±0.5	φ21±0.8
	U	2±0.5	2±0.5	2±0.5	2±0.5	2±0.5	2±0.5	2±0.5	2±0.5	2±0.5
	W	13.5±1	12.4+2/-0	16.4±0.5	13.5+2/-0	16.4±0.5	13.5+2/-0	13.5+2/-0	16.4±0.5	17.5+1/-0.5
Qty		2000	3000	3000	1000	3000	1000	1000	3000	1000

THE NEW VALUE FRONTIER



RF Modules

Antenna Switch Modules

Bluetooth™ Modules





Pb Free

RoHS Compliant

Features

- Small size
- Low loss
- Built-in 2LPF for receiver

Applications

- GSM900/DCS

How to Order

LM - D 5 18 S2 - 2 □
① ② ③ ④ ⑤ ⑥

- ① Series
- ② Circuit

D Dual

- ③ Type
- ④ Height

18 1.8mm max.

- ⑤ S2: GSM900/DCS
- ⑥ Custom Specification

Dimensions

(Unit : mm)

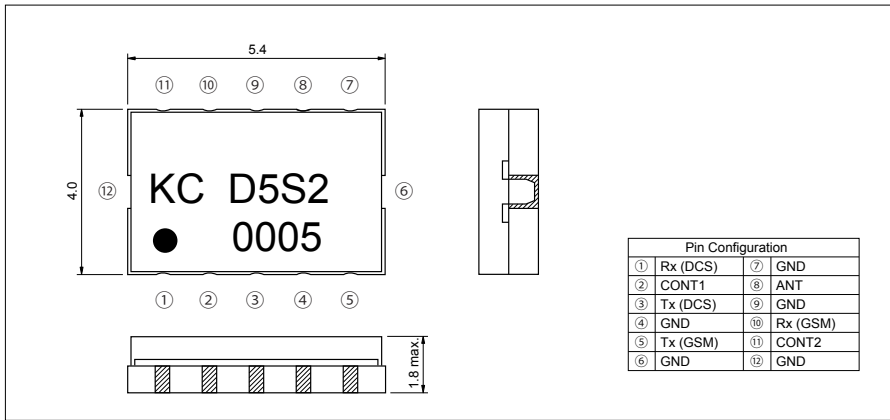

Specifications

(at 25°C)

Part No.	GSM					DCS				
	TX			RX		TX			RX	
	Freq. (MHz)	Ins. Loss (dB)	Att. (2*f0, 3*f0) (dB)	Freq. (MHz)	Ins. Loss (dB)	Freq. (MHz)	Ins. Loss (dB)	Att. (2*f0, 3*f0) (dB)	Freq. (MHz)	Ins. Loss (dB)
LM-D518S2-2	880 to 915	≤1.1	≥30	925 to 960	≤1	1710 to 1785	≤1.3	≥25	1805 to 1880	≤1.2

Recommended Land Pattern

(Unit : mm)

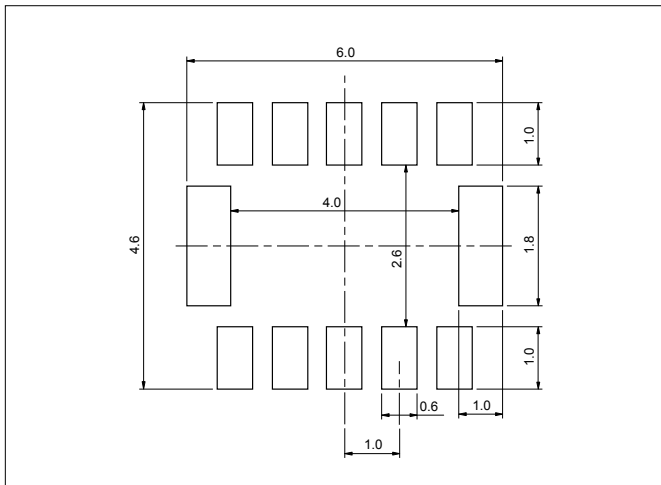

Recommended Reflow Profile

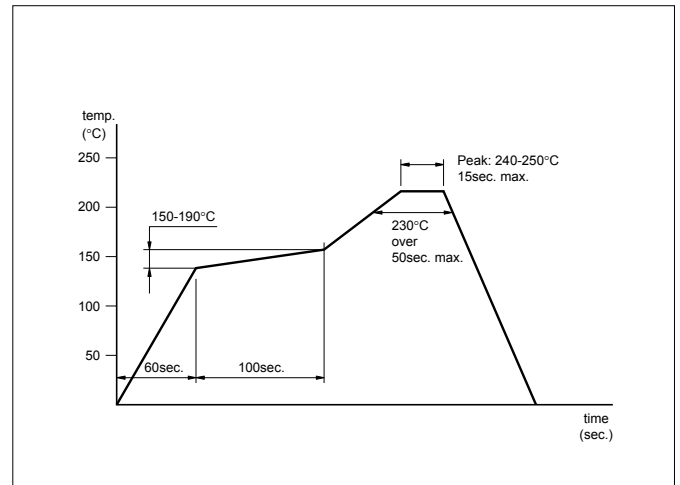



Pb Free

RoHS Compliant

Features

- Small and low profile
- Low loss
- Built-in 2LPF for receiver
- Excellent shock-resistant
- Support multiple bands (GSM850/GSM900/DCS (GSM1800)/ PCS (GSM1900))

Applications

- GSM850/ GSM900/ DCS/ PCS for Dual Band

How to Order

LM - D 6 15 S3
① ② ③ ④ ⑤

① Series

② Circuit

D Dual

③ Type

④ Height

15 1.5mm max.

⑤ Custom Specification

Dimensions (LM-D615S3) (Unit : mm)

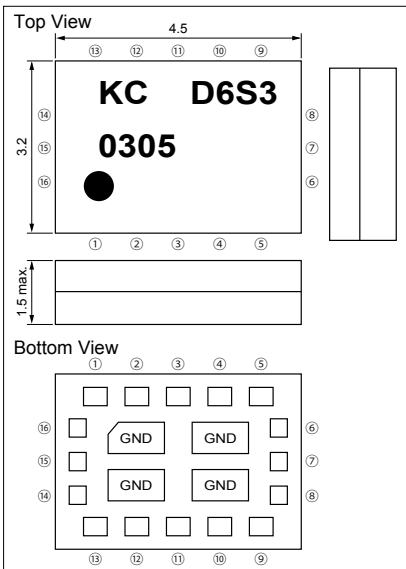

Pin Assingment (LM-D615S3)

①	GND
②	TX1 (GSM850/900)
③	GND
④	N.C
⑤	RX2 (DCS/PCS)
⑥	N.C
⑦	RX1 (GSM850/900)
⑧	N.C
⑨	N.C
⑩	VCont1
⑪	GND
⑫	ANT
⑬	GND
⑭	VCont2
⑮	GND
⑯	TX2 (DCS/PCS)

Dimensions (LM-D615S4) (Unit : mm)

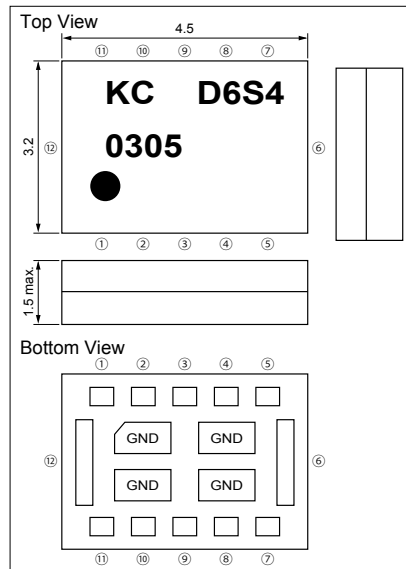

Pin Assingment (LM-D615S4)

①	RX2 (DCS/PCS)
②	VCont1
③	TX2 (DCS/PCS)
④	GND
⑤	TX1 (GSM850/900)
⑥	GND
⑦	GND
⑧	ANT
⑨	GND
⑩	RX1 (GSM850/900)
⑪	VCont2
⑫	GND

Specifications

(at 25°C)

Part No.	GSM (850/900)					DCS/PCS				
	TX			RX		TX			RX	
	Freq. (MHz)	Ins. Loss (dB)	Att. (2*f ₀ , 3*f ₀) (dB)	Freq. (MHz)	Ins. Loss (dB)	Freq. (MHz)	Ins. Loss (dB)	Att. (2*f ₀ , 3*f ₀) (dB)	Freq. (MHz)	Ins. Loss (dB)
LM-D615S3	824 to 849	≤1.2	≥35(2*f ₀), ≥30(3*f ₀)	869 to 894	≤1.1	1710 to 1785	≤1.4	≥30	1805 to 1880	≤1.3
	880 to 915			925 to 960		1850 to 1910			1930 to 1990	
LM-D615S4	824 to 849	≤1.2	≥35(2*f ₀), ≥30(3*f ₀)	869 to 894	≤1	1710 to 1785	≤1.4	≥25	1805 to 1880	≤1.2
	880 to 915			925 to 960		1850 to 1910			1930 to 1990	

Recommended Land Pattern

(Unit : mm)

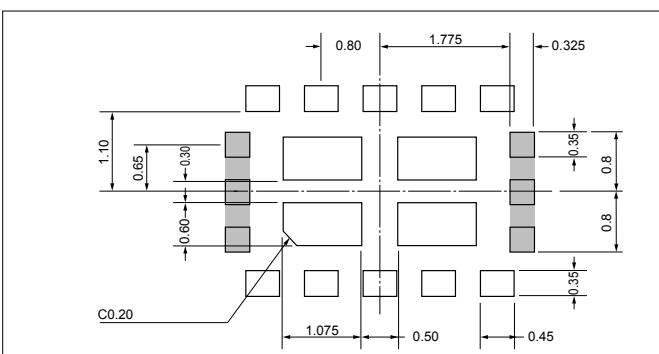

Shaded land area for LM-D615S4.

Recommended Reflow Profile

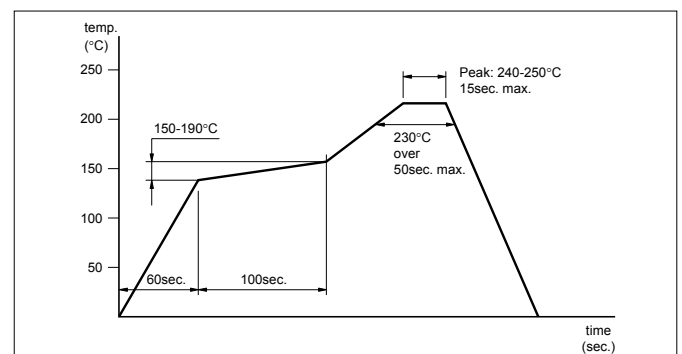



Pb Free

RoHS Compliant

Features

- Small and low profile
- Low loss
- Built-in 2LPF for receiver
- Excellent shock-resistant
- Support multiple bands (GSM850/GSM900/DCS (GSM1800)/ PCS (GSM1900))

Applications

- GSM850/ GSM900/ DCS/ PCS for Triple Band

How to Order

LM - T 6 15 S3
① ② ③ ④ ⑤

① Series

② Circuit

T Triple

③ Type

④ Height

15 1.5mm max.

⑤ Custom Specification

Dimensions (LM-T615S2)

(Unit : mm)

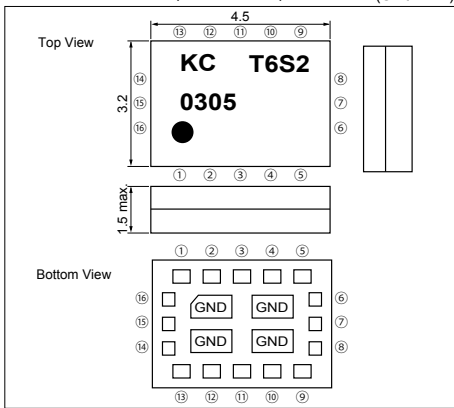

Dimensions (LM-T615S3)

(Unit : mm)

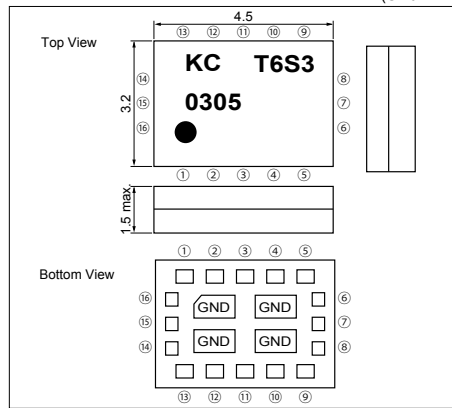

Pin Assingment (LM-T615S2)

① GND	⑨ GND
② N.C	⑩ ANT
③ RX1 (GSM850/900)	⑪ N.C
④ RX2 (DCS)	⑫ GND
⑤ RX3 (PCS)	⑬ GND
⑥ VCont1	⑭ TX2 (DCS/PCS)
⑦ VCont2	⑮ GND
⑧ VCont3	⑯ TX1 (GSM850/900)

Pin Assingment (LM-T615S3)

① GND	⑨ N.C
② TX1 (GSM850/900)	⑩ VCont1
③ GND	⑪ GND
④ RX3 (PCS)	⑫ ANT
⑤ RX2 (DCS)	⑬ GND
⑥ N.C	⑭ VCont2
⑦ RX1 (GSM850/900)	⑮ GND
⑧ N.C	⑯ TX2 (DCS/PCS)

Specifications

(at 25°C)

Part No.	GSM (850/900)					DCS/PCS				
	TX			RX		TX			RX	
	Freq. (MHz)	Ins. Loss (dB)	Att. (2*f0, 3*f0) (dB)	Freq. (MHz)	Ins. Loss (dB)	Freq. (MHz)	Ins. Loss (dB)	Att. (2*f0, 3*f0) (dB)	Freq. (MHz)	Ins. Loss (dB)
LM-T615S2	824 to 849	≤1.2	≥30(2*f0), ≥30(3*f0)	869 to 894	≤1	1710 to 1785	≤1.5	≥30 (2*f0, 3*f0)	1805 to 1880	≤1.4
	880 to 915			925 to 960		1850 to 1910			1930 to 1990	
LM-T615S3	824 to 849	≤1.2	≥30(2*f0), ≥30(3*f0)	869 to 894	≤1	1710 to 1785	≤1.5	≥30 (2*f0, 3*f0)	1805 to 1880	≤1.4
	880 to 915			925 to 960		1850 to 1910			1930 to 1990	

Recommended Land Pattern

(Unit : mm)

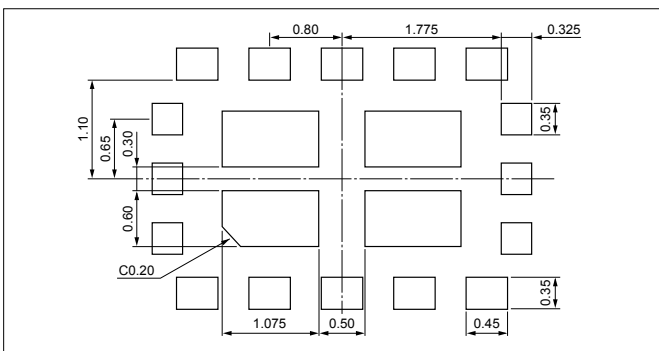

Recommended Reflow Profile

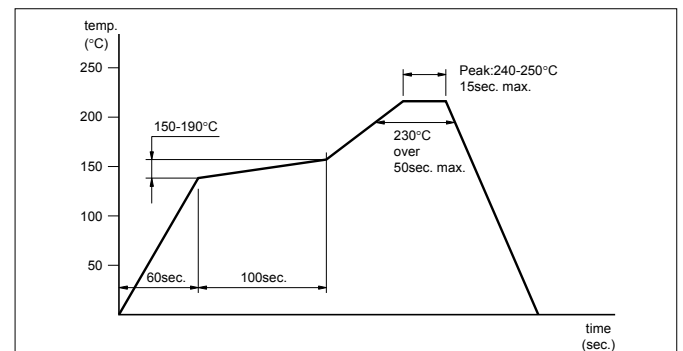



Pb Free

RoHS Compliant

Features

- Small and low profile
- Low current consumption
- Built-in 2LPF for receiver
- Built-in ESD protection circuit
- Excellent shock-resistant
- Support multiple bands (GSM850/GSM900/DCS (GSM1800)/ PCS (GSM1900))
- Include ESD protection

Applications

- GSM/ Quad System

How to Order

LX - Q 6 14 S2 E
① ② ③ ④ ⑤ ⑥

① Series

② Circuit

Q Quad

③ Type

④ Height

15 1.4mm max.

⑤ Custom Specification

⑥ ESD Protection

E Built-in ESD Protection Circuit

Dimensions

(Unit : mm)

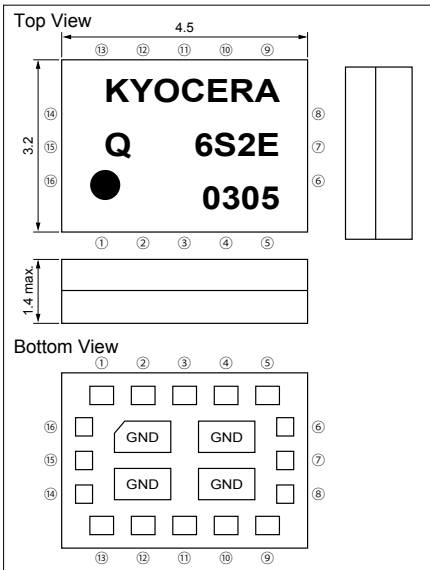

Pin Assingment

① GND	⑨ GND
② RX1 (GSM850)	⑩ ANT
③ RX2 (GSM900)	⑪ V _{DD}
④ RX3 (DCS)	⑫ GND
⑤ RX4 (PCS)	⑬ GND
⑥ VCont1	⑭ TX2 (DCS/PCS)
⑦ VCont2	⑮ GND
⑧ VCont3	⑯ TX1 (GSM850/900)

Specifications

(at 25°C)

Part No.	GSM (850/900)					DCS/PCS				
	TX			RX		TX			RX	
	Freq. (MHz)	Ins. Loss (dB)	Att. (2*f ₀ , 3*f ₀) (dB)	Freq. (MHz)	Ins. Loss (dB)	Freq. (MHz)	Ins. Loss (dB)	Att. (2*f ₀ , 3*f ₀) (dB)	Freq. (MHz)	Ins. Loss (dB)
LX-Q614S2E	824 to 849	≤1.45	≥30 (2*f ₀ , 3*f ₀)	869 to 894	≤1.5	1710 to 1785	≤1.55	≥30 (2*f ₀ , 3*f ₀)	1805 to 1880	≤1.5
	880 to 915			925 to 960		1850 to 1910			1930 to 1990	

Recommended Land Pattern

(Unit : mm)

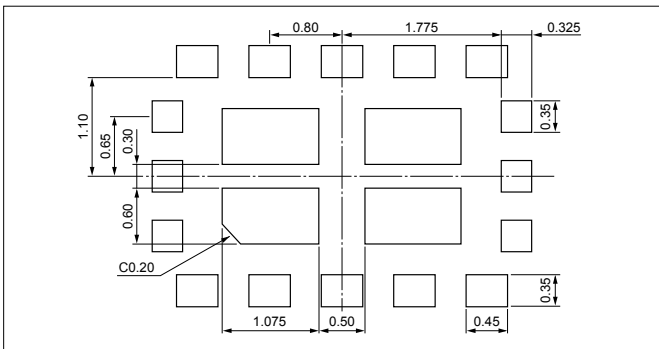

Recommended Reflow Profile

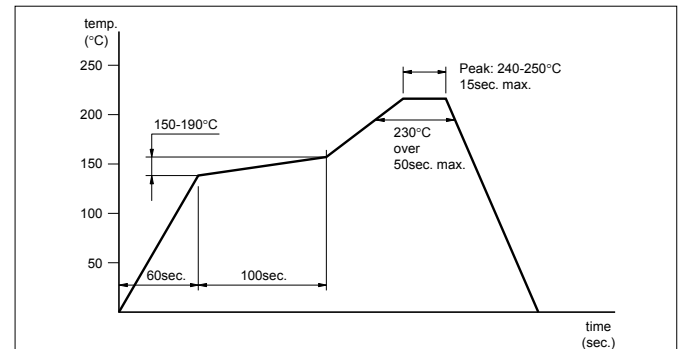



Features

- Low loss and low current consumption with GaAs switch
- Excellent insertion loss of UMTS pass with typical 0.6dB
- Excellent isolation to Rx DCS with minimum of 32dB
- Rx terminal is compatible with GSM850/ 900/ 1800/ 1900MHz

Applications

- GSM/ Quad + UMTS Single

How to Order

LX - P 6 12 S2
① ② ③ ④ ⑤

- ① Series
- ② Circuit

P GSM Quad + UMTS single

- ③ Type
- ④ Height

15 1.3mm max.

- ⑤ Custom Specification

Pb Free

RoHS Compliant

Dimensions

S1 (LX-P612S1)

(Unit : mm)

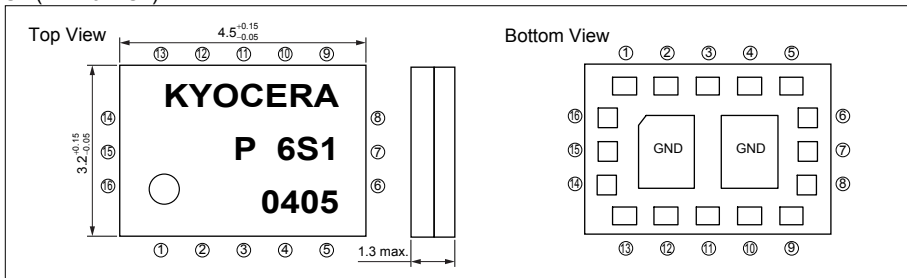

S2 (LX-P612S2)

(Unit : mm)

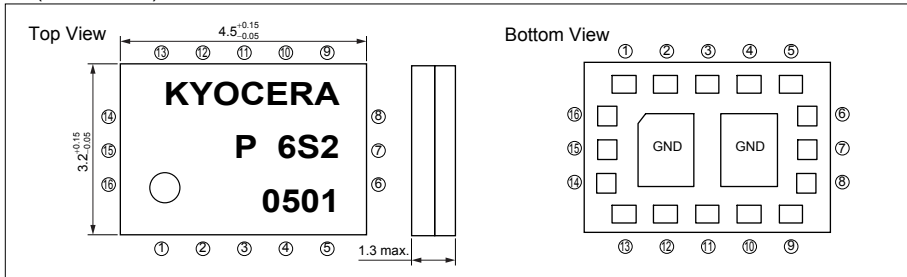

Pin Assigment

(LX-P612S1)

①	RX2(GSM850/900/DCS/PCS)	⑨	GND
②	RX3(GSM850/900/DCS/PCS)	⑩	ANT
③	RX4(GSM850/900/DCS/PCS)	⑪	GND
④	RX1(GSM850/900/DCS/PCS)	⑫	TRX (UMTS)
⑤	GND	⑬	Vdd
⑥	TX2(DCS/PCS)	⑭	Vc1
⑦	GND	⑮	Vc2
⑧	TX1(GSM850/900)	⑯	Vc3

(LX-P612S2)

①	RX2(GSM850/900/DCS/PCS)	⑨	TRX (UMTS)
②	RX3(GSM850/900/DCS/PCS)	⑩	Vdd
③	RX4(GSM850/900/DCS/PCS)	⑪	GND
④	RX1(GSM850/900/DCS/PCS)	⑫	ANT
⑤	GND	⑬	GND
⑥	TX2(DCS/PCS)	⑭	Vc1
⑦	GND	⑮	Vc2
⑧	TX1(GSM850/900)	⑯	Vc3

Specifications

(at 25°C)

Part No.	GSM (850/900)					DCS/PCS					UMTS		
	TX		RX		Freq. (MHz)	Ins. Loss (dB)	Att. (dB)	TX		RX		TX	
	Freq. (MHz)	Ins. Loss (dB)	Att. (dB)	Freq. (MHz)				Ins. Loss (dB)	Att. (dB)	Freq. (MHz)	Ins. Loss (dB)	Att. (dB)	Freq. (MHz)
LX-P612S1	824 to 849	≤1.2	≥67 (2*fo, 3*fo)	869 to 894	≤1.05	1710 to 1785	≤1.4	≥65 (2*fo, 3*fo)	1805 to 1880	≤1.3	1710 to 1785	≤0.85	≥65(2*fo, 3*fo)
	880 to 915			925 to 960									
LX-P612S2	824 to 849	≤1.2	≥67 (2*fo, 3*fo)	869 to 894	≤1.05	1710 to 1785	≤1.4	≥65 (2*fo, 3*fo)	1805 to 1880	≤1.3	1710 to 1785	≤0.85	≥65(2*fo, 3*fo)
	880 to 915			925 to 960									

Recommended Land Pattern

(Unit : mm)

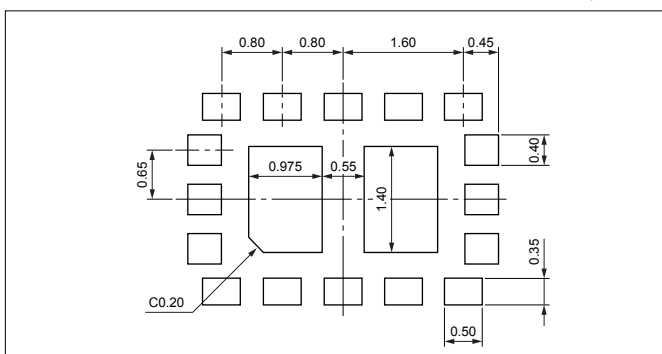

Recommended Reflow Profile

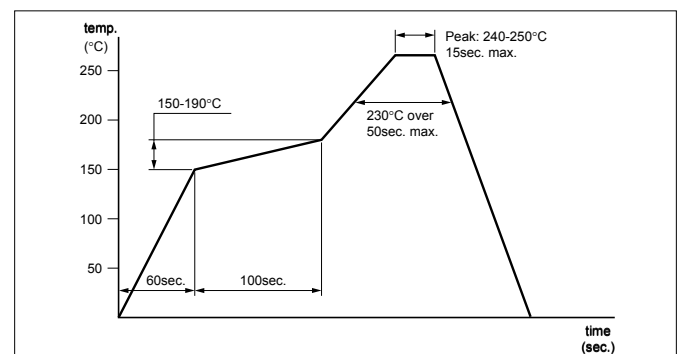

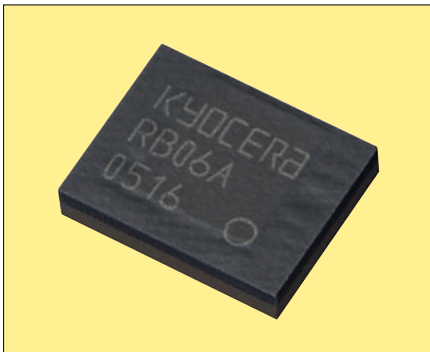

Pb Free

RoHS Compliant

Features

- Best solution for CDMA cell phone with bluetooth function
- Miniature size of 5.0 × 4.0 × 1.1mm
- Improved reception sensitivity (−88dBm typ)
- Low power consumption (Tx: 36mA typ, Rx: 38mA typ)
- Wide operating temperature range of −30 to +85°C

Dimensions

(Unit : mm)

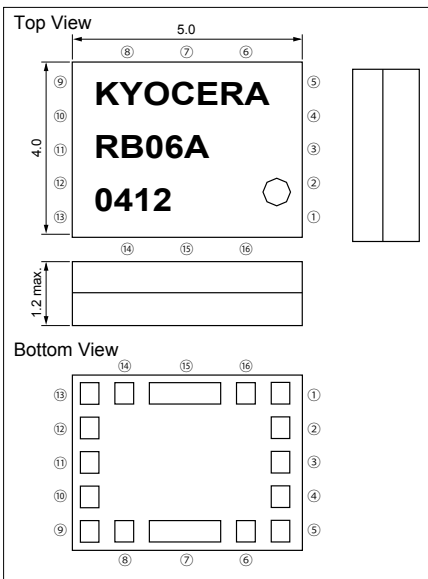

Pin Assignments

①	GND	⑨	CLK_REF
②	LDO1	⑩	SBCK
③	LDO2	⑪	SBDT
④	XTAL_IN	⑫	VDD_MSM
⑤	SYNC_DET/TX_EN	⑬	N.C
⑥	SBST	⑭	VDD_A
⑦	GND	⑮	GND
⑧	RX_BB/TX_BB	⑯	ANT

Specifications

	Unit	min.	typ	max.
Power Supply VDD_MSM	V	2.5	2.7	2.9
Current Consumption				
Receive Mode	mA	–	37	40
Transmit Mode	mA	–	36	40
Standby Mode	μA	–	20	50
Ambient Temperature	°C	−30	25	85
Receiver RF Specifications				
RCV/CA/02/C (Sensitivity-Multi Slot Packets) DH5	dBm	–	−88	−81
Transmitter RF Specifications				
TRM/CA/01/C (Output Power) Class 2 Pave	dBm	−2	–	3

Recommended Land Pattern

(Unit : mm)

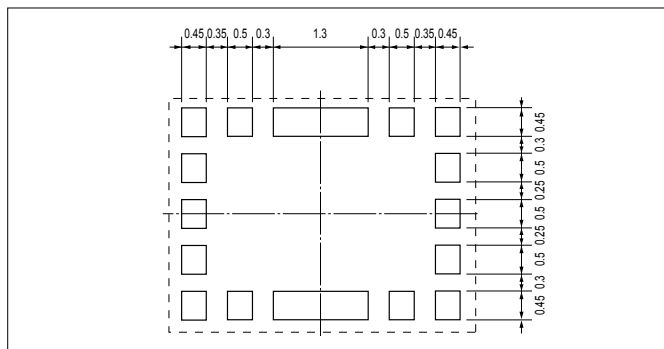

Recommended Reflow Profile

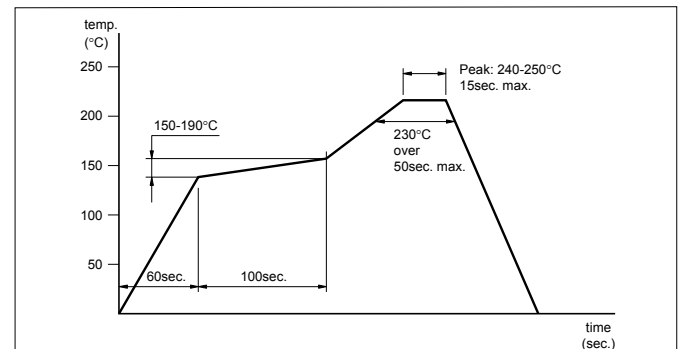

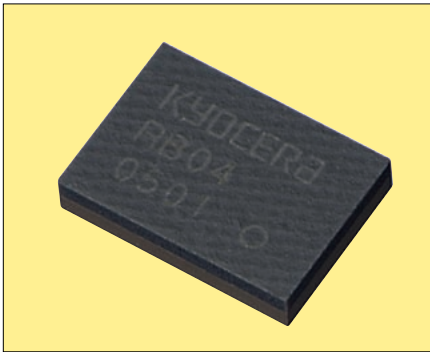

Pb Free

RoHS Compliant

Features

- Best solution for CDMA cell phone with bluetooth function
- Miniature size of 4.5 × 3.2 × 1.1mm
- Improved reception sensitivity (−88dBm typ)
- Low power consumption (Tx: 36mA typ, Rx: 38mA typ)
- Wide operating temperature range of −30 to +85°C

Dimensions

(Unit : mm)

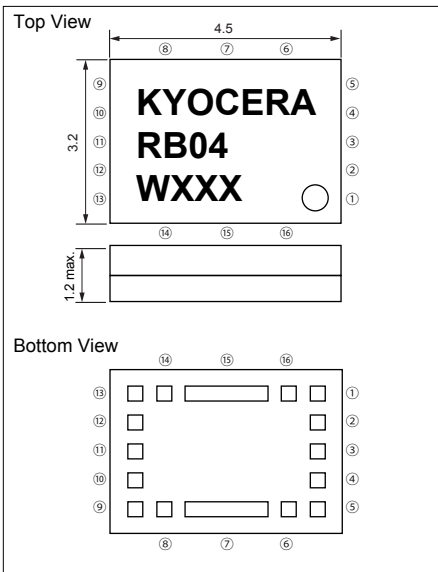

Pin Assignments

①	GND	⑨	CLK_REF
②	LDO1	⑩	SBCK
③	LDO2	⑪	SBDT
④	XTAL_IN	⑫	VDD_MSM
⑤	SYNC_DET/TX_EN	⑬	N.C
⑥	SBST	⑭	VDD_A
⑦	GND	⑮	GND
⑧	RX_BB/TX_BB	⑯	ANT

Specifications

	Unit	min.	typ	max.
Power Supply VDD_MSM	V	2.5	2.7	2.9
Current Consumption				
Receive Mode	mA	–	37	40
Transmit Mode	mA	–	36	40
Standby Mode	μA	–	20	50
Ambient Temperature	°C	−30	25	85
Receiver RF Specifications				
RCV/CA/02/C (Sensitivity-Multi Slot Packets) DH5	dBm	–	−88	−81
Transmitter RF Specifications				
TRM/CA/01/C (Output Power) Class 2 Pave	dBm	−2	–	3

Recommended Land Pattern

(Unit : mm)

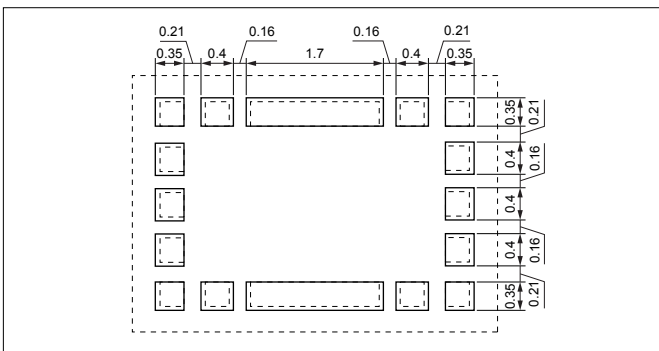

Recommended Reflow Profile

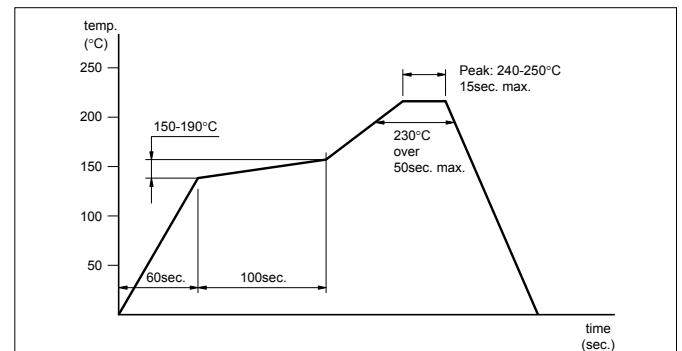

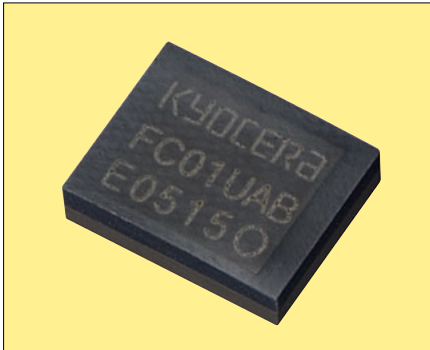

Pb Free

RoHS Compliant

Features

- Bluetooth HCI module
- Ultra-miniature size of 5.0 × 4.0 × 1.4mm
- Wide operating temperature range of -20 to +70°C
- Memory and clock unit are need to be attached
- Ver 1.2 compatible
- Class 2

Dimensions

(Unit : mm)

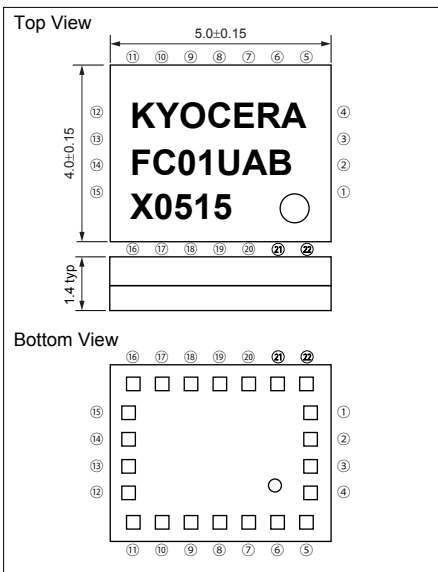

Pin Assignments

①	GND	⑫	GND
②	CAP	⑬	CLK
③	GND	⑭	GND
④	PCM	⑮	PIO
⑤	PCM	⑯	PIO
⑥	PCM	⑰	V IO
⑦	PCM	⑱	VDD
⑧	UART	⑲	GND
⑨	UART	⑳	RST
⑩	UART	㉑	GND
⑪	UART	㉒	ANT

Specifications

	Unit	min.	typ.	max.
Power Supply VDD_MSM	V	2.2	-	3.6
Ambient Temperature	°C	-20	25	70
Receiver RF Specifications RCV/CA/02/C (Sensitivity-Multi Slot Packets) DH5	dBm	-	-80	-72
Transmitter RF Specifications TRM/CA/01/C (Output Power) Class 2 Pave	dBm	-6	-	4

Recommended Land Pattern

(Unit : mm)

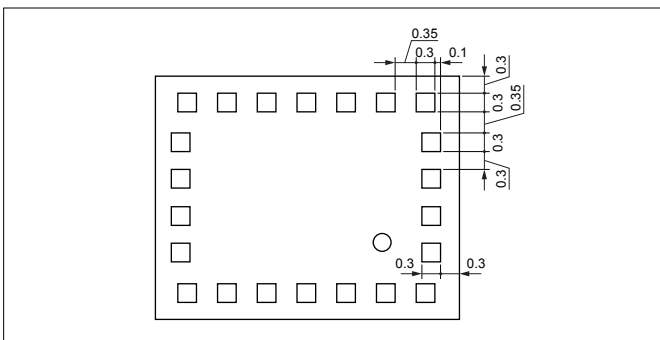

Recommended Reflow Profile

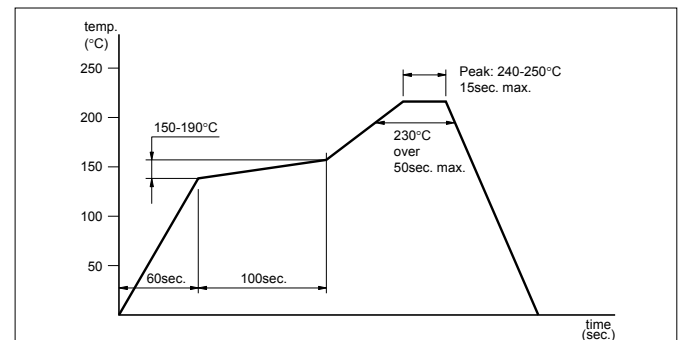

THE NEW VALUE FRONTIER



Others

Shock Sensors
Piezo Ceramic Elements
Piezo Buzzers





RoHS Compliant

Features

- Charge sensitivity type shock sensor
- 0 and 25 degree inclined angle available
- Small size, low profile, high sensitivity
- Tape and reel packaging available
- Reflow solderable

Applications

- Data Protection for Disc Media such as HDD, DVD, CD-R/RW etc.
- Shock Detection for Air Bag System

How To Order

PSAC 38 0 A - R
① ② ③ ④ ⑤

- ① Series
- ② Size
- ③ Inclined Angle (0: 0°, 2: 25°)
- ④ Type
- ⑤ Packaging (R: Tape and Reel)

Dimensions

(Unit : mm)

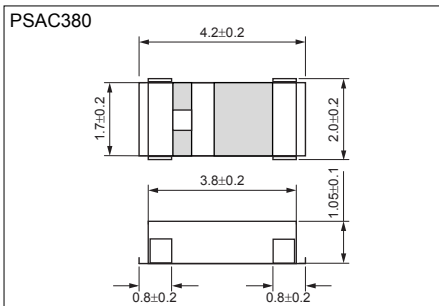
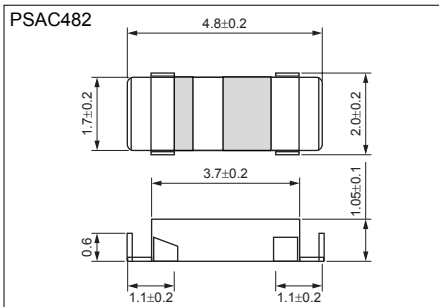

Recommended Land Pattern

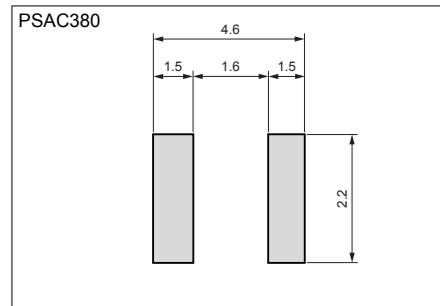
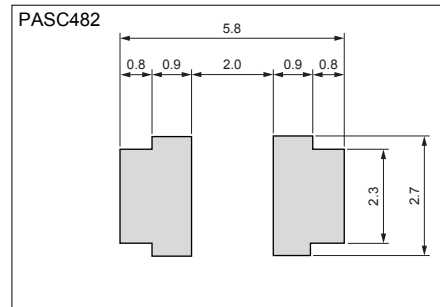

Recommended Reflow Profile

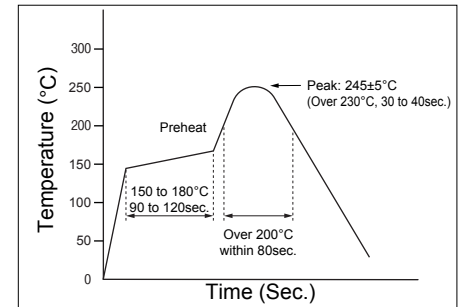

Packaging

(Unit : mm)

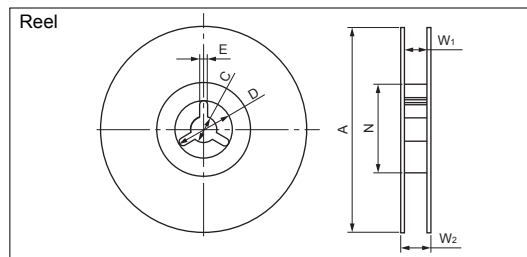
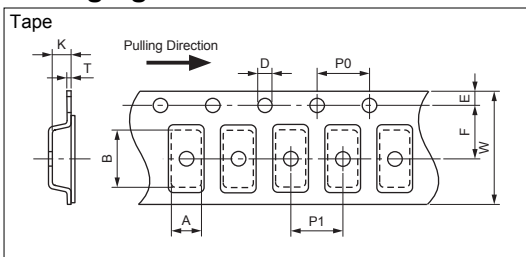

Part No.	Symbol	A	B	W	E	F
PSAC482	Dimension	2.5±0.1	5.1±0.1	12.0±0.2	1.75±0.1	5.5±0.1
PSAC380	Dimension	2.3±0.1	4.8±0.1	12.0±0.2	1.75±0.1	5.5±0.1
Parts No.	Symbol	P0	P1	D	K	T
PSAC482	Dimension	4.0±0.1	4.0±0.1	1.5±0.1/0	1.25±0.1	0.3±0.05
PSAC380	Dimension	4.0±0.1	4.0±0.1	1.5±0.1/0	1.3±0.1	0.3±0.05

Symbol	A	N	W1	W2
Dimension	180±5.0	60 min.	12.5 +2.0/-0.0	20.5 max.
Symbol	C	D	E	
Dimension	13.0±0.2	21.0±0.8	2.0±0.5	

Specifications

Item	Inclined Angle	Capacitance	Charge Sensitivity	Resonant Frequency	Isolated Resistance	Non-linearity
Part No.	(degree)	(pF)	(pC/G)	(kHz)	(GΩ)	(%)
PSAC482S-R	25±3	315±30%	0.25±30%	23±30%	0.5 min.	5 max.
PSAC380A-R	0±3	400±30%	0.15±30%	30±30%	0.5 min.	5 max.



Features

- Wide variety of tones by connecting to IC
- Low current consumption, thin and light design
- High reliability and no contact noise

Applications

- Clocks, Electronic Calculators, Pagers, Cameras
- Equipment Using Microcontrollers (Microwave Ovens, TVs, Stereos, Automobiles, etc.)
- Telecommunications (Facsimile Machines, Telephones)
- Electronic Medical Instruments

How to Order

KBS - 20 DA - 7 A □ -1
 ① ② ③ ④ ⑤ ⑥ ⑦

- ① Series
- ② Diameter (mm)
- ③ Appearance (Disc-Shaped Buzzer)
- ④ Resonant Frequency
- ⑤ 2-Electrode Type
(A: Element Only, C: With Lead)
- ⑥ Metal (Blank: Brass)
- ⑦ Option Spec (Lead-wire Spec etc.)

Dimensions

(Unit : mm)

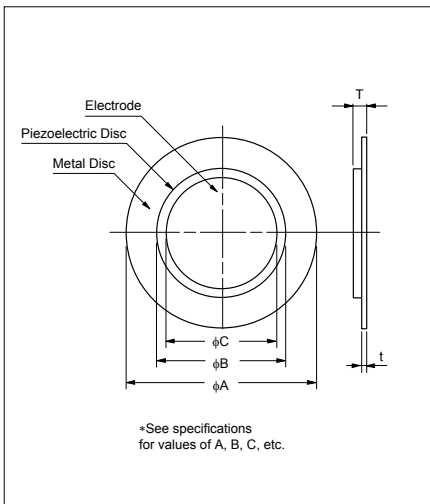

Standard Leads

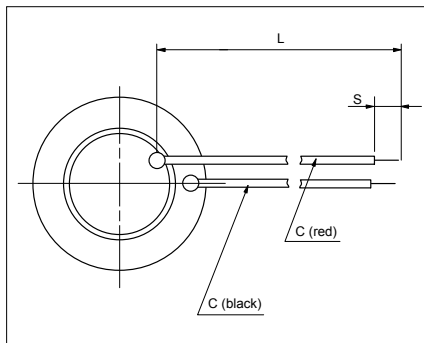

W: Thickness	AWG-32 UL-1571
L: Length (mm)	50±5, 75±5, 100±10
S: Strip (mm)	3±1
C: Color	red, black

Specifications (A type)

Part Number	Resonant Frequency [kHz]	Resonant Impedance [Ω]	Capacitance [pF]	Dimensions (mm)					Metal Disc Material
				Metal Disc (φA)	Ceramic Disc (φB)	Electrode (φC)	Total Thickness (T)	Metal Disc Thickness (t)	
KBS-13DA-12A	12.0±1.2	700	5,000±30%	13.4±0.1	10.0±0.3	(9.0)	0.36±0.1	0.15±0.03	Brass
KBS-15DA-9A-2	10.5±3.0	600	8,000±30%	15.0±0.1	12.0±0.3	(11.0)	0.42±0.1	0.20±0.03	Brass
KBS-20DA-7A	6.6±1.0	300	10,000±30%	20.0±0.1	14.2±0.3	(13.0)	0.45±0.1	0.20±0.03	Brass
KBS-23DA-4A	4.0±1.0	600	12,000±30%	22.8±0.1	15.0±0.3	(14.0)	0.41±0.1	0.15±0.03	Brass
KBS-27DA-5A	4.6±0.5	200	20,000±30%	27.0±0.1	20.2±0.3	(19.0)	0.53±0.1	0.25±0.03	Brass
KBS-30DA-1A	1.4±0.5	500	*48,000±30%	30.0±0.1	20.2±0.3	(19.0)	0.23±0.1	0.10±0.03	Brass
KBS-35DA-3A	2.9±0.5	200	30,000±30%	35.0±0.1	25.0±0.5	(23.5)	0.53±0.1	0.25±0.03	Brass

* Measured at 120Hz, all others at 1kHz



Features

- High sound pressure level and clear sound by connecting to a self oscillating circuit
- Thin and light design
- High reliability and no contact noise

Applications

- Smoke Detectors, Security Alarms and Other Warning Devices
- Pagers, Electronic Calculators, Alarm Signals
- Telephones

How to Order

KBS - 35 DA - 3 G □ - 3
 ① ② ③ ④ ⑤ ⑥ ⑦

- ① Series
- ② Diameter (mm)
- ③ Appearance (Disc-Shaped Buzzer)
- ④ Resonant Frequency
- ⑤ 3-Electrode Type
(G: G-Pattern, GC: G-Pattern with Leads)
- ⑥ Metal (Blank: Brass)
- ⑦ Option Spec (Lead-wire Spec etc.)

Dimensions

(Unit : mm)

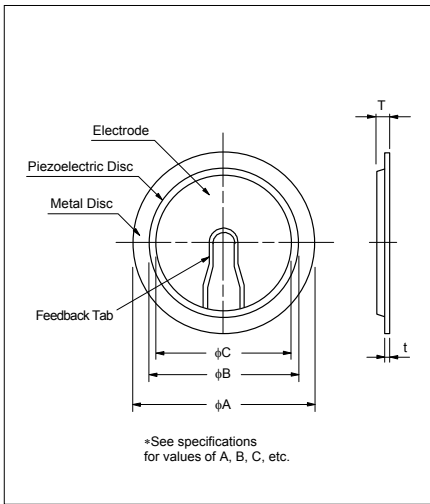

Standard Leads

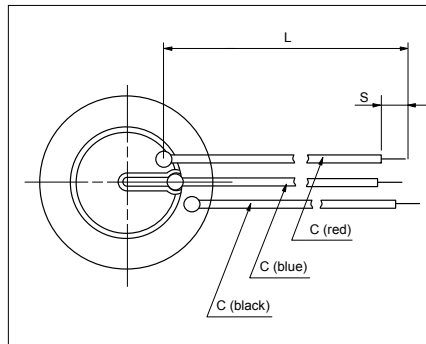

W: Thickness	AWG-32 UL-1571
L: Length (mm)	50±5, 75±5, 100±10
S: Strip (mm)	3±1
C: Color	red, black, blue

Specifications (G type)

Part Number	Resonant Frequency [kHz]	Resonant Impedance [Ω]	Capacitance [pF]	Dimensions (mm)					Metal Disc Material
				Metal Disc (φA)	Ceramic Disc (φB)	Electrode (φC)	Total Thickness (T)	Metal Disc Thickness (t)	
KBS-27DA-5G	4.6±0.5	200	16,000±30%	27.0±0.1	20.2±0.3	(19.0)	0.53±0.1	0.25±0.03	Brass
KBS-35DA-3G	2.9±0.5	200	25,000±30%	35.0±0.1	25.0±0.3	(23.6)	0.53±0.1	0.25±0.03	Brass

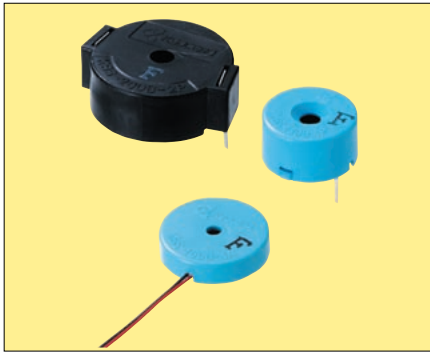

Features

- Low current consumption - high sound pressure
- Compact, light design
- High reliability and no contact noise
- Easy-mounting
- Wide variety of tones can be made by cavity designing
- Functions over a wide range of Input voltage

How to Order

KBS - 27 DB - 3 A
① ② ③ ④ ⑤

- ① Series
- ② Diameter (mm)
- ③ Appearance (Buzzer with Casing)
- ④ Resonant Frequency
- ⑤ Type of Terminals
(A: With Lead, P: Round Pin)

Applications

- Confirmation Tone for Various Office Automation Equipment
- Automobiles, Microwave Ovens, Refrigerators
- Clocks, Toys, Game Machines

Dimensions

(Unit : mm)

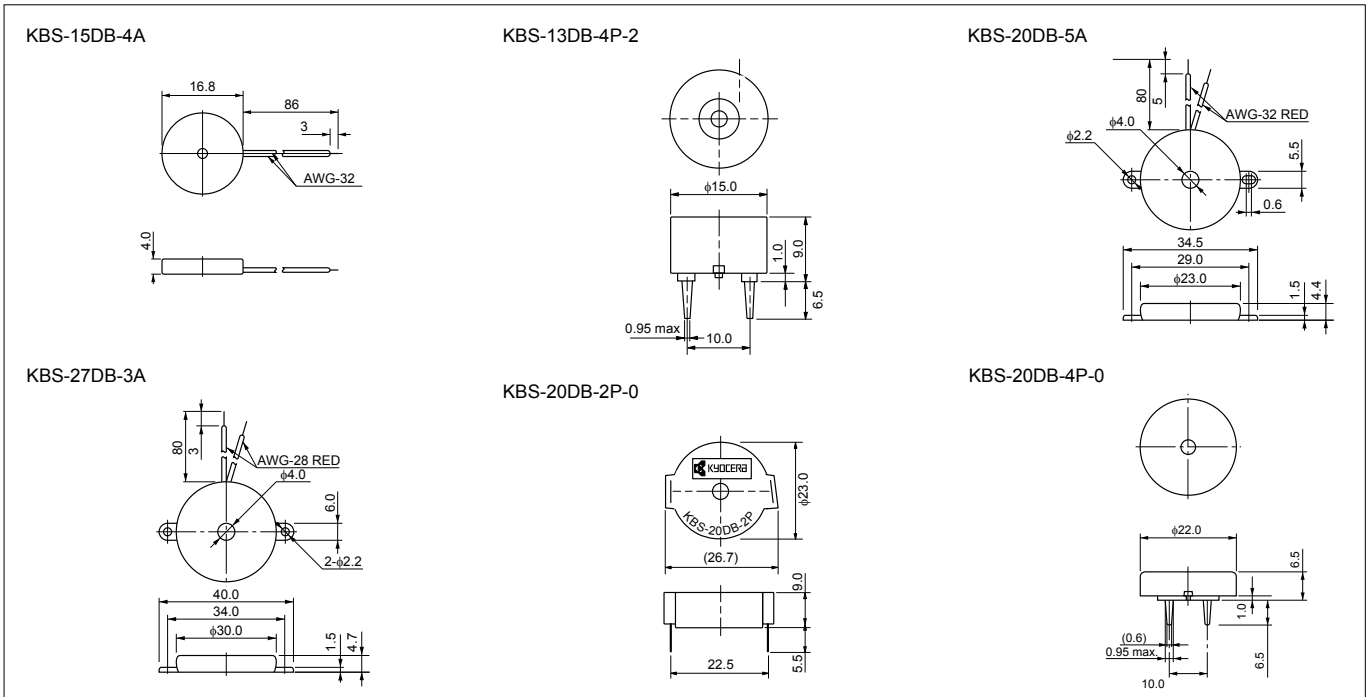

Specifications

Part Number	Sound Pressure Level	Capacitance
KBS-13DB-4P-2	73db min. 4.096kHz 10Vp-p SQ 30cm	10nF±30%
KBS-20DB-2P-0	75db min. 2.048kHz 10Vp-p SQ 30cm	24nF±30%
KBS-20DB-4P-0	77db min. 4.096kHz 10Vp-p SQ 30cm	14nF±30%
KBS-15DB-4A	72db min. 4.096kHz 10Vp-p SQ 30cm	9.5nF±30%
KBS-20DB-5A	75db min. 5.0kHz 10Vp-p SQ 30cm	10nF±30%
KBS-27DB-3A	75db min. 3.0kHz 10Vp-p SQ 30cm	20nF±30%

■ Manufacturing Plants (Kyocera & AVX Group)

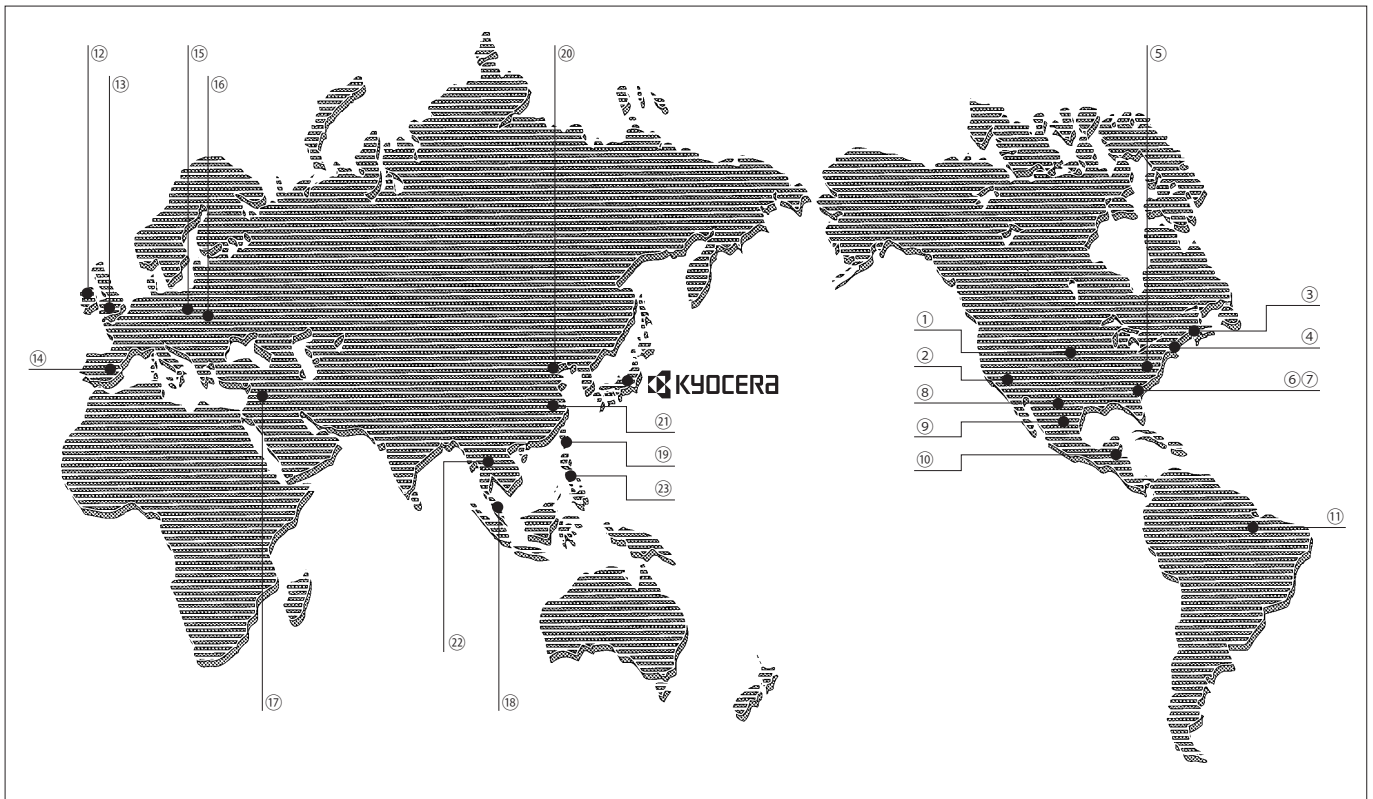

North America

Plant	Location
① Colorado	U.S.A
② Sun Valley	
③ Biddeford	
④ Olean	
⑤ Raleigh	
⑥ Conway	
⑦ Myrtle Beach	

Central, South America

Plant	Location
⑧ Juarez	Mexico
⑨ Chihuahua	
⑩ El Salvador	El Salvador
⑪ Manaus	Brazil

Europe

Plant	Location
⑫ Coleraine	Ireland
⑬ Paignton	U.K.
⑭ Dijon	France
⑮ Lanskrout	Czech
⑯ Üherskê	

Middle East

Plant	Location
⑰ Jerusalem	Israel

Asia

Plant	Location
⑱ Penang	Malaysia
⑲ Taiwan	Taiwan
⑳ Tianjin	P.R.C

KYOCERA Plant

Plant	Location
㉑ SKE	Shanghai

KYOCERA KINSEKI Plant

Plant	Location
㉒ KYOCERA KINSEKI ELECTRONICS (Thailand)	Thailand
㉓ KYOCERA KINSEKI PHILIPPINES	Philippines

Kyocera Network in Japan



KYOCERA Headquarters



KYOCERA KINSEKI Headquarters

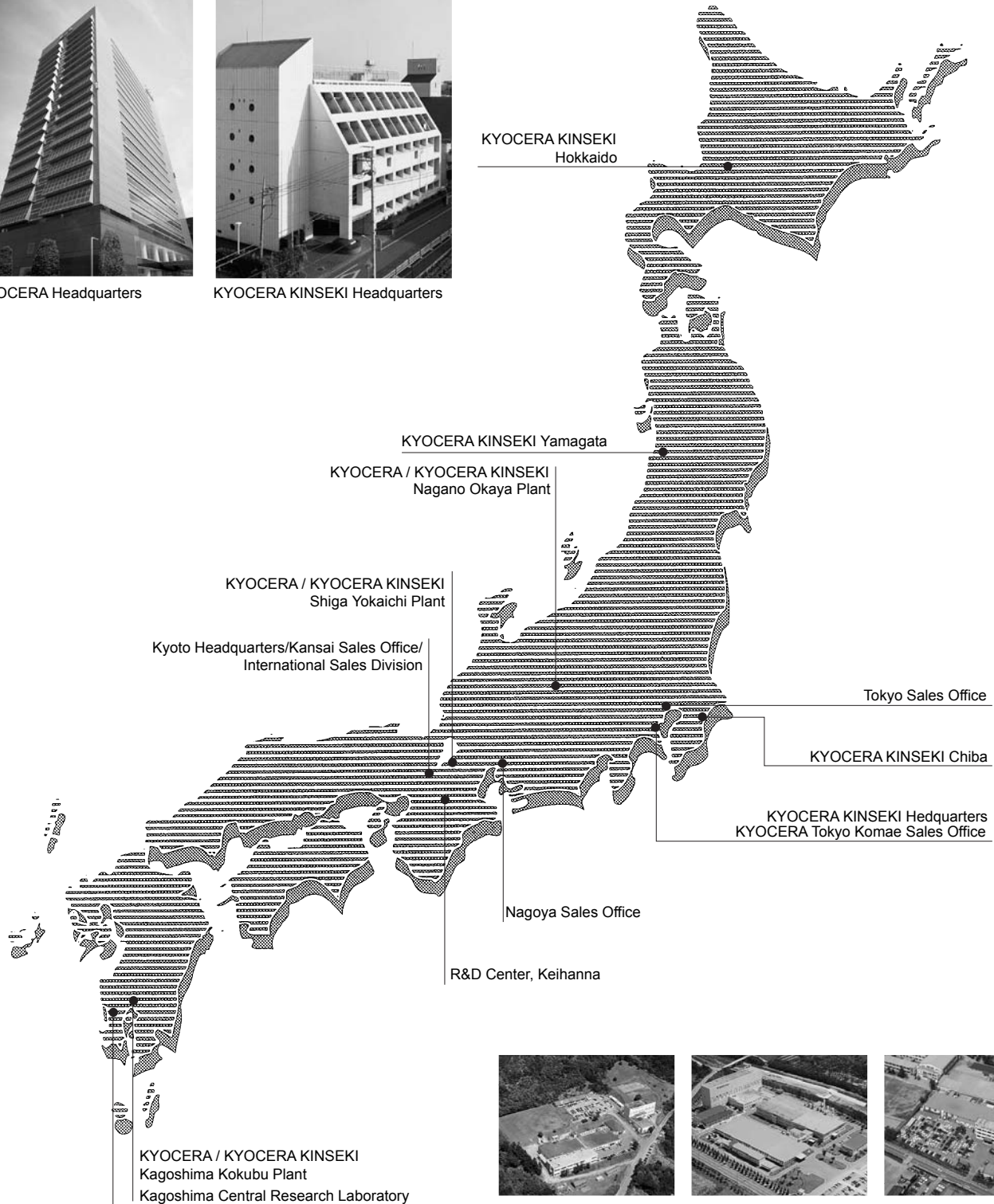

KYOCERA
Kagoshima Sendai Plant



KYOCERA / KYOCERA KINSEKI
Nagano Okaya Plant



KYOCERA KINSEKI
Hokkaido Corporation



KYOCERA KINSEKI
Yamagata Corporation



KYOCERA KINSEKI
Chiba Corporation



KYOCERA / KYOCERA KINSEKI
Shiga Yohaichi Plant



KYOCERA
Kagoshima Sendai Plant



KYOCERA / KYOCERA KINSEKI
Kagoshima Kokubu Plant

Sales Offices

KYOCERA CORPORATION

*Electronic Components International Sales Division
6 Tobadono-cho, Fushimi-ku, Kyoto 612-8501, Japan
Phone: (81)-(75)604-3424 Fax: (81)-(75)604-3425

KYOCERA ELECTRONIC DEVICES (KED)

*KYOCERA Electronic Devices LLC, US Headquarters

4350 International Parkway, Suite C, Atlanta, GA 30354
Phone: (1)-(404)477-2453 Fax: (1)-(404)477-2466

- KYOCERA Electronic Devices LLC, Chicago Office
5105 Tollview Drive, Suite 130, Rolling Meadows, IL 60008
Phone: (1)-(847)392-1077 Fax: (1)-(847)392-1179
- KYOCERA Electronic Devices LLC, San Diego Office
5897 Oberlin Drive, Suite 205 San Diego, CA 92121
Phone: (1)-(858)643-9293 Fax: (1)-(858)643-9295
- KYOCERA Electronic Devices LLC, Santa Clara Office
2340-A Walsh Avenue, Santa Clara, CA 95051
Phone: (1)-(408)988-4900 Fax: (1)-(408)988-4901

*KYOCERA Electronic Devices UK Ltd European Headquarters

Admiral House, Harlington Way, Fleet, Hampshire, GU51 4BB, England
Phone: (44) 1252 770 000 Fax: (44) 1252 770 009

KYOCERA Electronic Devices Singapore Pte Ltd

151 Lorong Chuan Lobby G #03-07 New Tech Park, Singapore 556741
Phone: (65)-6343-0400 Fax: (65)-6280-5580

KYOCERA Electronic Devices Hong Kong Ltd

Unit 1801, 18/F., Tower 3, Enterprise Square, No.9
Sheung Yuet Road, Kowloon Bay, Kowloon, Hong Kong
Phone: (852)-2305-1080 Fax: (852)-2305-1405

- KYOCERA Electronic Devices Hong Kong Ltd, Shanghai Rep Office
12E Majesty Building, 138 Pudong Ave., Shanghai, PRC 200120
Phone: (86)-(21)6859-9898 Fax: (86)-(21)5887-2542

KYOCERA Electronic Devices Taiwan Ltd

4th Floor, No.33, Section 1, Mingsheng Road, Banciao City, Taipei
County, Taiwan
Phone: (886)-(2)2950-0268 Fax: (886)-(2)2950-0520

KYOCERA Electronic Devices Korea Yuhan Hoesa

11th Fl, Korea Life Insurance 63 Bldg, #60, Yoido-Dong,
Youngdeungpo-ku, Seoul, 150-763, Korea
Phone: (82)-2783-3288 Fax: (82)-2783-3207

KYOCERA ASIA PACIFIC GROUP

- KYOCERA Asia Pacific Pte Ltd (Singapore)
298 Tiong Bahru Road, #13-03/05 Central Plaza, Singapore 168730
Phone: (65)-6271-0500 Fax: (65)-6271-0600
- KYOCERA Asia Pacific Pte Ltd (Taipei Branch)
10F, No.66, Nanking West Road, Taipei, Taiwan
Phone: (886)-2-2555-3609 Fax: (886)-2-2559-4131
- KYOCERA Asia Pacific Ltd (Hong Kong)
Rm 803, Tower 1, South Seas Centre, 75 Mody Road, Tsimshatsui
East, Kowloon, Hong Kong
Phone: (852)-2723-7183 Fax: (852)-2724-4501
- KYOCERA Asia Pacific Pte Ltd (Manila Branch)
Unit 203/204, Alpap II Building, Trade Street Corner Investment Drive,
Madrigal Business Park, Ayala Alabang, Muntinlupa City, Philippines
Phone: (63)-2-7750533 Fax: (63)-2-7750532
- KYOCERA Asia Pacific (Thailand) Co Ltd
159 Serm-Mit Tower 19th Floor, Sukhumvit 21 Road, North
Klongtoey, Wattana, Bangkok 10110, Thailand
Phone: (66)-2-661-6400 Fax: (66)-2-661-6413
- KYOCERA (Malaysia) Sdn Bhd
Lot 4A, Lower Level 5, Hotel Equatorial Penang, No.1 Jalan Bukit
Jambul, 11900 Penang, malaysia
Phone: (60)-4-641-4190 Fax: (60)-4-641-4205

KYOCERA (TIANJIN) SALES & TRADING CORPORATION

- Shanghai Office
Information Tower 11th Floor, 211 Century Avenue, Pudong New
Area, Shanghai, 200120 PRC
Phone: (86)-(21)-5877-5366 Fax: (86)-(21)-5888-5096
- Shenzhen Office
Suite D, E 23/F, A Fortune Plaza, 7060 Shennan Bld., Futian
District, Shenzhen, 518040 PRC
Phone: (86)-(755)-82873625 Fax: (86)-(755)-82873640
- Beijing Office
19F, Tower C HeQiao Building 8A GuangHua Rd., Chao Yang
District, Beijing 100026, PRC
Phone: (86)-(10)-65832270 Fax: (86)-(10)-65832250

AVX CORPORATION

- North American Sales Headquarters
801 17th Ave. South , P.O. Box 867, Myrtle Beach, SC 29577
Phone: (1)-(843)448-9411 Fax: (1)-(843)448-1943
- Northwest Regional Office
12117 NE 99th Street, Suite 1930 Vancouver, WA 98682
Phone: (1)-(360)699-8746 Fax: (1)-(360)699-8751
- Southwest Regional Office
3120 N. Arizona Ave. Suite 102, Chandler, AZ 85225
Phone: (1)-(602)678-0384 Fax: (1)-(602)678-0385
- North Central Regional Office
3091 East 98th Street, Suite 180, Indianapolis, IN 46280
Phone: (1)-(317)848-7153 Fax: (1)-(317)844-9314
- South Central Regional Office
100 North Central Expressway, Suite 804, Richardson, TX 75080
Phone: (1)-(972)669-1223 Fax: (1)-(972)669-2090
- North Regional Office
1015 Matheson Blvd E, Unit 6 Mississauga, Ontario L4W 3A4 CANADA
Phone: (1)-(905)238-3151 Fax: (1)-(905)238-0319
- Southeast Regional Office
3900 Electronics Drive, Raleigh, NC 27604
Phone: (1)-(404)608-8151 Fax: (1)-(770)972-0766

AVX LIMITED

- European Sales Headquarters
Admiral House, Harlington Way, Fleet, Hampshire, GU51 4BB, England
Phone: (44) 1252 770 000 Fax: (44) 1252 770 001
- AVX GmbH (Germany)
Ohm str. 12 Haus 1, D-85757 Karlsfeld, Germany
Phone: (49) 8131 9004 0 Fax: (49) 8131 9004 44
- AVX S.A. (France)
ZA de Courtaboeuf B.P. 213, Miniparc 6 Av. des Andes, 91941
LES ULIS Cedex, France
Phone: (33) 1 69 18 46 00 Fax: (33) 1 69 28 73 87
- AVX S.R.L (Italy)
Via Galilei, 2 20091 Bresso, Milano, Italy
Phone: (39) 042614571 Fax: (39) 026142576
- AVX S.A. (Spain)
Crta. Boadilla No.26 Local-1, C.P. 28220 Majadahonda, Madrid, Spain
Phone: (34) 91 6397 197 Fax: (34) 91 6394 809

AVX/KYOCERA (Singapore) Pte Ltd

151 Lorong Chuan #06-05/06 New Tech Park, Singapore 577183
Phone: (65)-6286-7555 Fax: (65)-6488-9880

AVX/KYOCERA (HK) Ltd

- 3/F., Hilder Center, 2 Sung Ping Street, Hunghom, Kowloon Hong Kong
Phone: (852)-2363-3303 Fax: (852)-2765-8185

AVX/KYOCERA (HK) Ltd, Taiwan Branch

15F, 88, Hisn Tai Wn Road, Sec 1, His Chih, Taipei Hsien, Taiwan
Phone: (886)-(2)2696-4636 Fax: (886)-(2)2696-4237

AVX/KYOCERA (Malaysia) Sdn. Bhd.

Suite 3.3, 3rd Floor, Wisma Leader, 8 Jalan Larut, 10050 Penang, Malaysia
Phone: (60)-4-228-1190 Fax: (60)-4-228-1196

AVX/KYOCERA Yuhan Hoesa

10th Fl, Korea Life Insurance 63 Bldg, #60, Yeouido-Dong,
Yeongdeungpo-gu, Seoul, 150-763, Korea
Phone: (82)-2785-6504 Fax: (82)-2784-5411

AVX/KYOCERA (Shanghai) International Trading Co. Ltd.

Room 15A08, Marine Tower, No.1Pudong Ave. Shanghai, PRC 200120
Phone: (86)-(2)-6886-1000 Fax: (86)-(2)-6886-1010

AVX/KYOCERA (Tianjin) International Trading Co. Ltd.

Unit A, B, D, 7th Floor, Teng Da Building, No. 18 Teng Da Road Tianjin
Port Free Zone, Tianjin, PRC 300456
Phone: (86)-(22)-2576-0098 Fax: (86)-(22)-2576-0096

Tianjin AVX/KYOCERA International Trading Co., Ltd

Room 927, Towercrest Plaza
No.3, Mai Zi Dian West Road, Chao Yang District
Beijing, P.R. China 100016
Phone: (86)-(10)-8458-3385 / 3386 Fax: (86)-(10)-8458-3382

Notes for Using the Catalog

1. Specifications described in this catalog are for references. Products specifications shall be based on written documents agreed by each party.
2. Contents in this catalog are subject to change without notice. It is recommended to confirm the latest information at the time of usage. Also, Kyocera Electronic Components Catalog is revised once a year. We may not be able to accept requests based on old catalogs.
3. Products in this catalog are intended to be used in general electronic equipment such as office equipment, audio and visual equipment, communication equipment, measurement instrument and home appliances. It is absolutely recommended to consult with our sales representatives in advance upon planning to use our products in applications which require extremely high quality and reliability such as aircraft and aerospace equipment, traffic systems, safety systems, power plant and medical equipment including life maintenance systems.
4. Even though we strive for improvements of quality and reliability of products, it is requested to design with enough safety margin in equipment or systems in order not to threaten human lives directly or damage human bodies or properties by an accidental result of products.
5. It is requested to design based on guaranteed specifications for such as maximum ratings, operating voltage and operating temperature. It is not the scope of our guarantee for unsatisfactory results due to misuse or inadequate usage of products in the catalog.
6. Operation summaries and circuit examples in this catalog are intended to explain typical operation and usage of the product. It is recommended to perform circuit and assembly design considering surrounding conditions upon using products in this catalog.
7. Technical information described in this catalog is meant to explain typical operations and applications of products, and it is not intended to guarantee or license intellectual properties or other industrial rights of the third party or Kyocera.
8. Certain products in this catalog are subject to the Foreign Exchange and Foreign Trade Control Act of Japan, and require the license from Japanese Government upon exporting the product.
9. It is prohibited to reprint and reproduce a part or whole of this catalog without permission.
10. Contents described herein are as of October 2005.