

RS232 Board datasheet

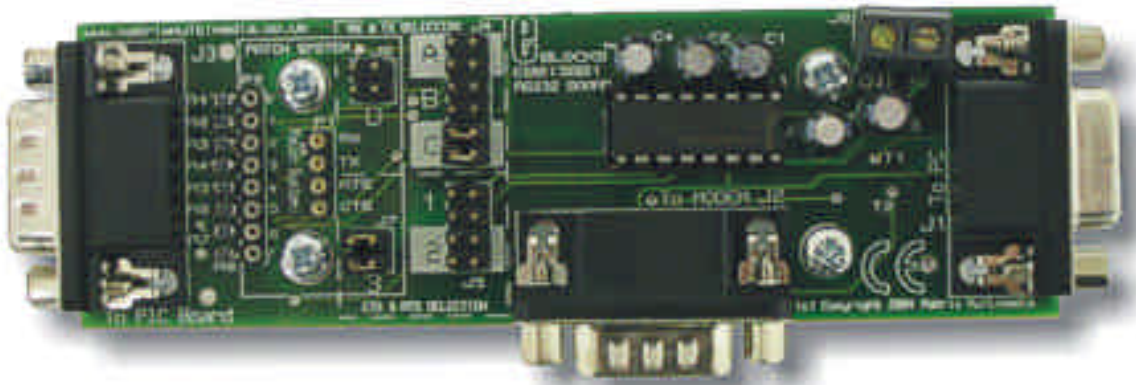
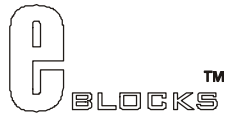

Contents

1. About this document
 2. General information
 3. Board Layout
 4. Getting Started
 5. Circuit Description
- Appendix
- 1 Circuit Diagram

1 About this document

This document concerns the Matrix RS232 Board code EB-015-00-1.

Trademarks and Copyright

PIC, PICmicro are registered trademarks of Arizona Microchip Inc.

E-blocks is a trademark of Matrix Multimedia Limited.

EB-015-00-1 and associated software and documentation are Copyright ©2004 Matrix Multimedia Limited.

Other sources of information

There are various other documents and sources that you may find useful:

Getting started with E-Blocks.pdf

This describes the E-blocks system and how it can be used to develop complete systems for learning electronics and for PICmicro programming.

PPP Help file

This describes the PPP software and its functionality. PPP software is used for transferring hex code to a PICmicro microcontroller.

Disclaimer

The information in this document is correct at the time of going to press. Matrix Multimedia reserves the right to change specifications from time to time.

Technical support

If you have any problems operating this product then please refer to the troubleshooting section of this document first. You will find the latest software updates, FAQs and other information on our web site:

www.matrixmultimedia.co.uk. If you still have problems please email us at:

support@matrixmultimedia.co.uk. When emailing please state the operating system, the version of PPP you are using.

2 General information

This E-block provides an RS232 interface which can be used to facilitate communication between PICmicro microcontroller and third party devices like PC serial ports, mobile communications systems etc. Flowcode macros for driving this E-block are available.

A set of jumper links are available which allow the RS232 E-blocks to easily be set for all PICmicro® microcontroller USART ports.

Flowcode macros that make this device easier to use are available.

Features

- RS232 communications between processors and a PC
- RS232 communications between processors and a modem
- Flowcode macros available
- Hardware flow control can be enabled as an option

3 RS232 Board Layout

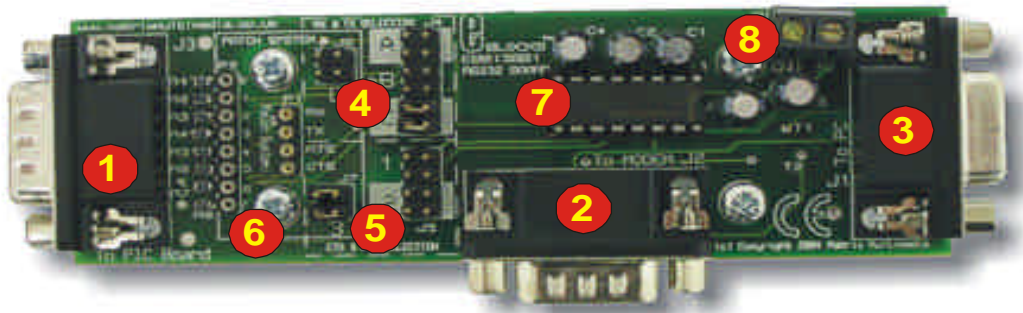

Important: Please note that the mode selection jumpers are orientated in the correct way – i.e. with the metal connect strips HORIZONTAL as shown in the picture above.

- 1) 9-way downstream D-type connector
- 2) RS232 interface for third party devices
- 3) PC interface
- 4) RX and TX mode selection jumper pins
- 5) CTS and RTS mode selection jumper pins
- 6) Patch system
- 7) MAX232 device
- 8) Screw terminal

General Guide for CTS and RTS settings

Jumper Settings	Description
1	Hardware Flow Control (RX = bit 4, TX = bit 0)
2	No flow control
3	Hardware flow control (Patch)

General Guide for TX and RX settings

Jumper at A	Jumper at B	Jumper at C		Jumper at D
PIC16F88 PIC16F87	PIC16F627(A) PIC16F628(A) PIC16F648A	PIC16F7x PIC16F7x7 PIC16F87x PIC16F87xA	PIC16C6x PIC16CC7x	Patch System

For more information on see Section 4 – Circuit Description

4 Getting Started

As can be seen the circuit diagram (Appendix 1) consists of a simple RS232 circuit. To test this board you will need to apply 5V to the RS232 Board via the screw terminal and then set the appropriate bits using the 9-Way D-type connector. The details off the RS232 configuration are stated in the Chapter 4 Circuit Description.

Testing the RS232 Board - RS232.hex

The following instructions explain the steps to test and use your RS232 Board. The instructions assume that PPP is installed and functional. It also assumes that you are confident in sending a program to the PIC via the Multiprogrammer.

This program using a 40-pin PIC16F877A device.

The RS232.hex program will enable you to communicate with your PC using a COM port on your computer.

Setting up the Hyperterminal

- 1 Open "Hyperterminal" – Start....Programs...Accessories.....Communication.....Hyperterminal
- 2 Create new connection: Either a pop-up window will appear to allow you to do this or you will have to go to "File....New connection". This will open the same same pop-up as previously mentioned.
- 3 Enter an appropriate name for the hyperterminal. The default Icon is fine to use.
- 4 Click Ok
- 5 Now "Connect to" pop-up screen will appear. This is where you need to select the appropriate COM port you are using. Select the correct COM port. Click Ok.
- 6 Now the "COM Properties" pop-up screen appears. The following setting should be set:
 - Bits per second = 9600
 - Data bits = 8
 - Parity = None
 - Stop bits = 1
 - Flow control = HardwareClick Ok.
- 7 Now check the your hyper terminal properties. Click "File.....Properties". Then when the pop-up window appears click on the Tab "Settings"
The following should be checked
 - "Terminals Keys" should be highlighted with a dot beside it
 - "Ctrl+H" should be highlighted with a dot beside it
 - Emulation = ANSIW
 - Tenet terminal ID = VT100
 - Backscroll buffer line = 500Now click on the "ASCII setup.." and check the following
 - "Echo types characters locally" should be highlighted with a tick beside it.
 - Line delay = 0
 - Character delay = 0
 - "Wrap lines that exceed terminal length" should be highlighted with a tick beside it.Now click Ok on the ASCII setup screen
Then click Ok on the Properties screen

Using the RS232 program

- 1 Ensure power is supplied to all the necessary boards.
- 2 Insert the RS232 board into Port C of the Multiprogrammer
- 3 Connect RS232 cable from your COM port to the 9-Way D-type J1 labelled "to PC"
- 4 Insert the LCD board (EB-005-00-1) into Port B of the Multiprogrammer
- 5 Ensure power is connect to all E-blocks via wires from "+V" of the mutliprogrammer to "+V" of each board – in this case both the RS232 board and the LCD board
- 6 Ensure that the Multiprogrammer is in correct configuration
 - Fast mode (SW1 towards the centre of the board)
 - Ensure that a 19.6608MHz crystal is inserted in the Multiprogrammer board
 - SW2 is not used when in Xtal mode so it doesn't matter it's position
- 7 Program the a PIC16F877A with the test program *RS232.hex*
- 8 Make sure jumpers "C" and "1" are selected on the RS232.
- 9 In the Hyperterminal ensure that there is a connection. Click on "Call...Call". If the Call command is not highlighted then Hyperterminal is already connected.
- 10 Press the reset button on the Multiprogrammer.
- 11 The word "Hello" should appear on the Hyperterminal screen. This has been sent to the Pc via the RS232 test program.
- 12 Now typing anything on the keyboard. This should automatically appear on the LCD screen.

This should satisfy that the RS232 Board is fully functional and communicating to and from the PC!

4 Circuit description

The circuit as can be seen in the circuit diagram below (See Appendix 1 – Circuit diagram), is straightforward. The main device on the board is the MAX3232 – This is a low voltage level changer. It will convert the TTL output of the PICmicro device to a recognized RS232 voltage.

The design of this product is to enable you to use this device with many standard PICmicro devices. This is achieved by identifying the PICmicro. Then by selecting the corresponding jumper setting the RS232 board will be configured with the correct pin-out that particular device. Jumper setting A, B, and C are used for selecting the appropriate pins for RX and TX. Jumper settings 1, 2, and 3 are used to set the correct pins for CTS and RTS. The following tables illustrate the correct jumper settings.

Jumper Setting A	Jumper Setting B	Jumper Setting C		Jumper Setting D
		PIC16F devices	PIC16C devices	
PIC16F87	PIC16F627/A	PIC16F73	PIC16C63	PATCH SYSTEM
PIC16F88	PIC16F628/B	PIC16F737	PIC16CR63	
	PIC16F648A	PIC16F74	PIC16C65/A/B	
		PIC16F746	PIC16RC65	
		PIC16F76	PIC16C66	
		PIC16F767	PIC16C73/A/B	
		PIC16F77	PIC16C74/A/B	
		PIC16F777	PIC16C745	
		PIC16F870/1	PIC16C765	
		PIC16F873/A	PIC16C77	
		PIC16F874/A	PIC16C773	
		PIC16F876/A	PIC16C774	
		PIC16F877/A	PIC16C774	

Table 1. Jumper settings for TX and RX selection.

The following table (Table 2) shows the settings that can be used for RTS and CTS. These signals are not essential for RS232 communication, and therefore you have an option (Jumper setting 2) to disable CTS and RTS.

Jumper Setting 1		Jumper Setting 2		Jumper Setting 3	
CTS	RTS	CTS	RTS	CTS	RTS
Bit 4	Bit 0	CTS not used	RTS not used	Patch	Patch

Table 2. Jumper settings for RTS and CTS selection

The Patch System allows the user to route RX, TX, CTS and RTS to any 8 of the bits that they require. This allows great flexibility, as the user can then use a different device other than specified in Table 1.

DTE / DCE

RS232 communication historically existed between Data Terminal Equipment (DTE) and Data Communications Equipment (DCE), where DTE referred to the computer and DCE referred to the modem. Both types of device use 9-way D-type connectors, a DTE device has a male connector and a DCE device has a female connector.

This RS232 E-Block can be used as either a DTE or a DCE device. If it is to behave as a DCE device, connect the "To PC" connector to a DTE device (a PC, for example). If the PICmicro is to be a DTE device (for example, when you are using it in conjunction with the GSM mobile phone unit), then you will need to attach a DCE device to the RS232 E-Block via the "To Modem" connector.

Matrix Multimedia RS232 Board

Appendix 1 - Circuit Diagram

THIS SYSTEM INCLUDES:-

→ FEET

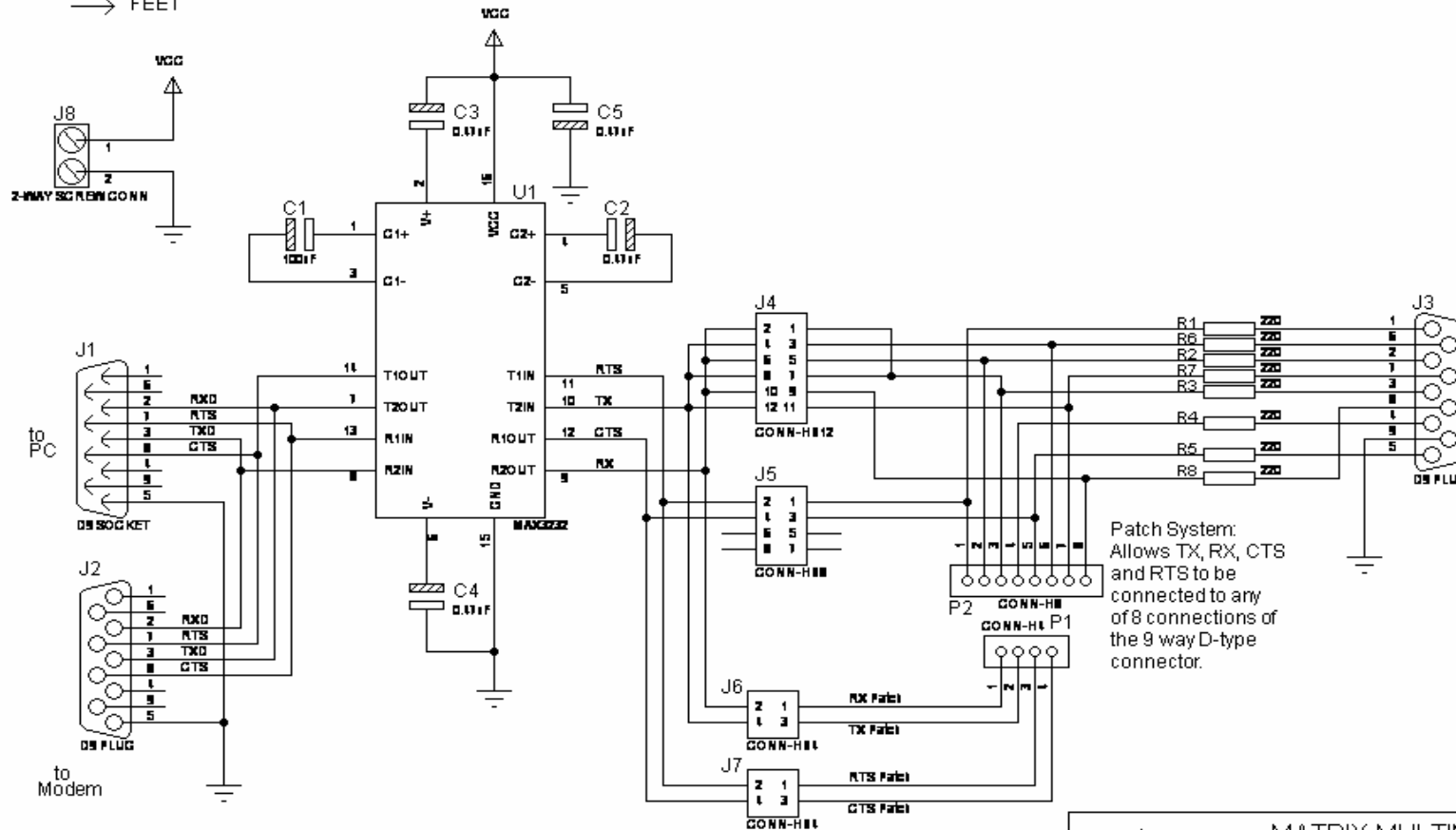

Patch System:
Allows TX, RX, CTS
and RTS to be
connected to any
of 8 connections of
the 9 way D-type
connector.

 MATRIX MULTIMEDIA LTD. www.matrixmultimedia.co.uk (c) Copyright 2004 Matrix Multimedia	
TITLE: RS232 Board EB-015-00-1	DATE: 12/05/04 PAGE: 1/1
BY: Colin Carr - Matrix Multimedia	REV: 1.0