

## Battery Holders

# Vertical Battery Holder for RENATA CR2032 VBH2032-1 for Through Hole Mounting

### Features

- Small PCB foot print
- Safe battery retention
- Easy and fast battery replacement
- Safety against inverse polarity
- Safety against inverse mounting
- Safety against leak currents

### Specifications

- Holder material: flame retardant Polyamide UL flammability class 94V-0
- Contacts: spring stainless steel, nickel plated throughout, thickness 5µm min.
- Temperature range: -30°C to +70°C

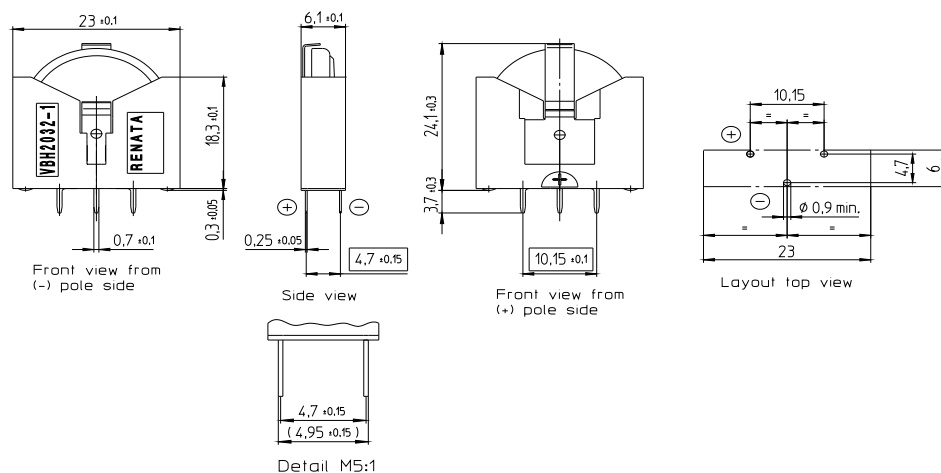
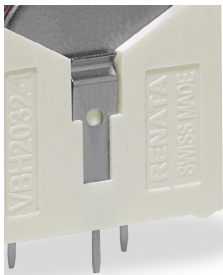

Dimensions (mm)

Rev. 10/02