

FEATURES

- Low Standby-Current Consumption of 10 μ A Max
- I²C to Parallel-Port Expander
- Open-Drain Interrupt Output
- Compatible With Most Microcontrollers
- 400-kHz Fast I²C Bus
- Address by Three Hardware Address Pins for Use of up to Eight Devices
- Latched Outputs With High-Current Drive Capability for Directly Driving LEDs
- Latch-Up Performance Exceeds 100 mA Per JESD 78, Class II
- ESD Protection Exceeds JESD 22
 - 2000-V Human-Body Model (A114-A)
 - 200-V Machine Model (A115-A)
 - 1000-V Charged-Device Model (C101)

DB, DBQ, DGV, DW, OR PW PACKAGE
(TOP VIEW)

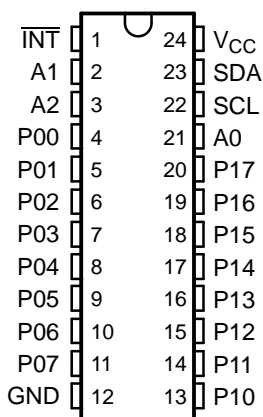

RHL PACKAGE
(TOP VIEW)

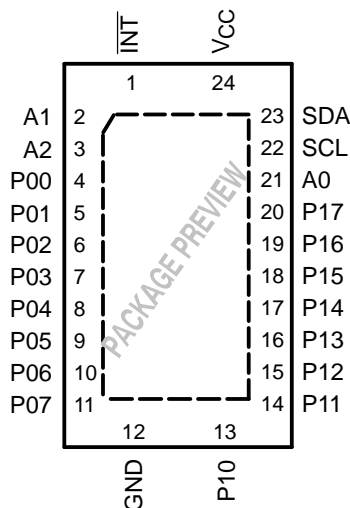

RGE PACKAGE
(TOP VIEW)

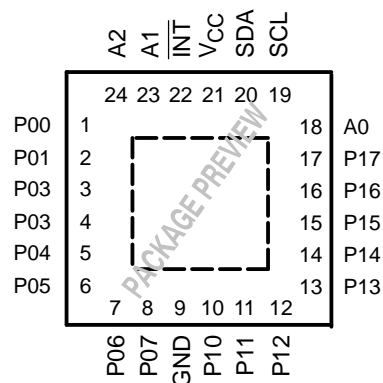

DESCRIPTION/ORDERING INFORMATION

This 16-bit I/O expander for the two-line bidirectional bus (I²C) is designed for 4.5-V to 5.5-V V_{CC} operation.

ORDERING INFORMATION

T _A	PACKAGE ⁽¹⁾		ORDERABLE PART NUMBER	TOP-SIDE MARKING
–40°C to 85°C	QSOP – DBQ	Reel of 2500	PCF8575CDBQR	PCF8575C
	TVSOP – DGV	Reel of 2000	PCF8575CDGVR	PF575C
	SOIC – DW	Tube of 25	PCF8575CDW	PCF8575C
		Reel of 2000	PCF8575CDWR	
	SSOP – DB	Tube of 60	PCF8575CDB	PF575C
		Reel of 2000	PCF8575CDBR	
	TSSOP – PW	Tube of 60	PCF8575CPW	PF575C
		Reel of 1200	PCF8575CPWR	
		Reel of 250	PCF8575CPWT	
QFN – RGE	Reel of 3000	PCF8575CRGER	PREVIEW	
QFN – RHL	Reel of 1000	PCF8575CRHLR	PREVIEW	

(1) Package drawings, standard packing quantities, thermal data, symbolization, and PCB design guidelines are available at www.ti.com/sc/package.



Please be aware that an important notice concerning availability, standard warranty, and use in critical applications of Texas Instruments semiconductor products and disclaimers thereto appears at the end of this data sheet.

PCF8575C

REMOTE 16-BIT I²C AND SMBus LOW-POWER I/O EXPANDER WITH INTERRUPT OUTPUT

SCPS123A—MARCH 2005—REVISED SEPTEMBER 2005

DESCRIPTION/ORDERING INFORMATION (CONTINUED)

The PCF8575C provides general-purpose remote I/O expansion for most microcontroller families via the I²C interface serial clock (SCL) and serial data (SDA).

The device features a 16-bit quasi-bidirectional input/output (I/O) port (P07–P00, P17–P10), including latched outputs with high-current drive capability for directly driving LEDs. Each quasi-bidirectional I/O can be used as an input or output without the use of a data-direction control signal. At power on, the I/Os are in 3-state mode. The strong pullup to V_{CC} allows fast-rising edges into heavily loaded outputs. This device turns on when an output is written high and is switched off by the negative edge of SCL. The I/Os should be high before being used as inputs. After power on, as all the I/Os are set to 3-state, all of them can be used as inputs. Any change in setting of the I/Os as either inputs or outputs can be done with the write mode. If a high is applied externally to an I/O that has been written earlier to low, a large current (I_{OL}) flows to GND.

The PCF8575C provides an open-drain interrupt (\overline{INT}) output, which can be connected to the interrupt input of a microcontroller. An interrupt is generated by any rising or falling edge of the port inputs in the input mode. After time (t_{iv}), the signal \overline{INT} is valid. Resetting and reactivating the interrupt circuit is achieved when data on the port is changed to the original setting, or data is read from or written to the port that generated the interrupt. Resetting occurs in the read mode at the acknowledge (ACK) bit after the rising edge of the SCL signal or in the write mode at the ACK bit after the falling edge of the SCL signal. Interrupts that occur during the ACK clock pulse can be lost (or be very short), due to the resetting of the interrupt during this pulse. Each change of the I/Os after resetting is detected and is transmitted as \overline{INT} . Reading from or writing to another device does not affect the interrupt circuit.

By sending an interrupt signal on this line, the remote I/O can inform the microcontroller if there is incoming data on its ports, without having to communicate via the I²C bus. Thus, the PCF8575C can remain a simple slave device.

Every data transmission to or from the PCF8575C must consist of an even number of bytes. The first data byte in every pair refers to port 0 (P07–P00), and the second data byte in every pair refers to port 1 (P17–P10). To write to the ports (output mode), the master first addresses the slave device, setting the last bit of the byte containing the slave address to logic 0. The PCF8575C acknowledges and the master sends the first data byte for P07–P00. After the first data byte is acknowledged by the PCF8575C, the second data byte (P17–P10) is sent by the master. Once again, the PCF8575C acknowledges the receipt of the data, after which this 16-bit data is presented on the port lines.

The number of data bytes that can be sent successively is not limited. After every two bytes, the previous data is overwritten. When the PCF8575C receives the pairs of data bytes, the first byte is referred to as P07–P00 and the second byte as P17–P10. The third byte is referred to as P07–P00, the fourth byte as P17–P10, and so on.

Before reading from the PCF8575C, all ports desired as input should be set to logic 1. To read from the ports (input mode), the master first addresses the slave device, setting the last bit of the byte containing the slave address to logic 1. The data bytes that follow on the SDA are the values on the ports. If the data on the input port changes faster than the master can read, this data may be lost.

When power is applied to V_{CC} , an internal power-on reset holds the PCF8575C in a reset state until V_{CC} has reached V_{POR} . At that time, the reset condition is released, and the device I²C-bus state machine initializes the bus to its default state.

The hardware pins (A0, A1, and A2) are used to program and vary the fixed I²C address, and allow up to eight devices to share the same I²C bus or SMBus. The fixed I²C address of the PCF8575C is the same as the PCF8575, PCF8574, PCA9535, and PCA9555, allowing up to eight of these devices, in any combination, to share the same I²C bus or SMBus.

PIN FUNCTIONS

DB, DBQ, DGV, DW, PW, AND RHL PIN NO.	RGE PIN NO.	NAME	FUNCTION
1	22	$\overline{\text{INT}}$	Interrupt output. Connect to V_{CC} through a pullup resistor.
2	23	A1	Address input 1. Connect directly to V_{CC} or ground. Pullup resistors are not needed.
3	24	A2	Address input 2. Connect directly to V_{CC} or ground. Pullup resistors are not needed.
4	1	P00	P-port input/output
5	2	P01	P-port input/output
6	3	P02	P-port input/output
7	4	P03	P-port input/output
8	5	P04	P-port input/output
9	6	P05	P-port input/output
10	7	P06	P-port input/output
11	8	P07	P-port input/output
12	9	GND	Ground
13	10	P10	P-port input/output
14	11	P11	P-port input/output
15	12	P12	P-port input/output
16	13	P13	P-port input/output
17	14	P14	P-port input/output
18	15	P15	P-port input/output
19	16	P16	P-port input/output
20	17	P17	P-port input/output
21	18	A0	Address input 0. Connect directly to V_{CC} or ground. Pullup resistors are not needed.
22	19	SCL	Serial clock line. Connect to V_{CC} through a pullup resistor
23	20	SDA	Serial data line. Connect to V_{CC} through a pullup resistor.
24	21	V_{CC}	Supply voltage

PCF8575C
REMOTE 16-BIT I²C AND SMBus LOW-POWER I/O EXPANDER
WITH INTERRUPT OUTPUT

SCPS123A—MARCH 2005—REVISED SEPTEMBER 2005

LOGIC DIAGRAM (POSITIVE LOGIC)

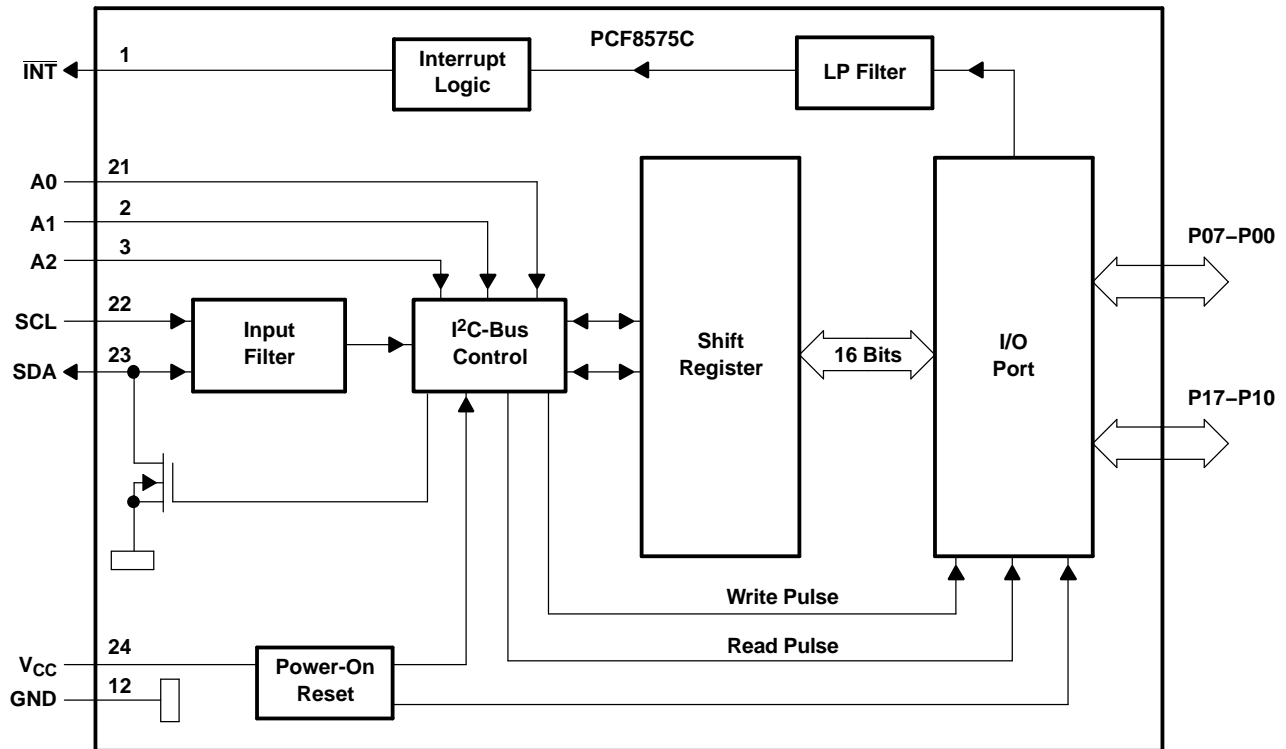

SIMPLIFIED SCHEMATIC DIAGRAM OF EACH P-PORT INPUT/OUTPUT

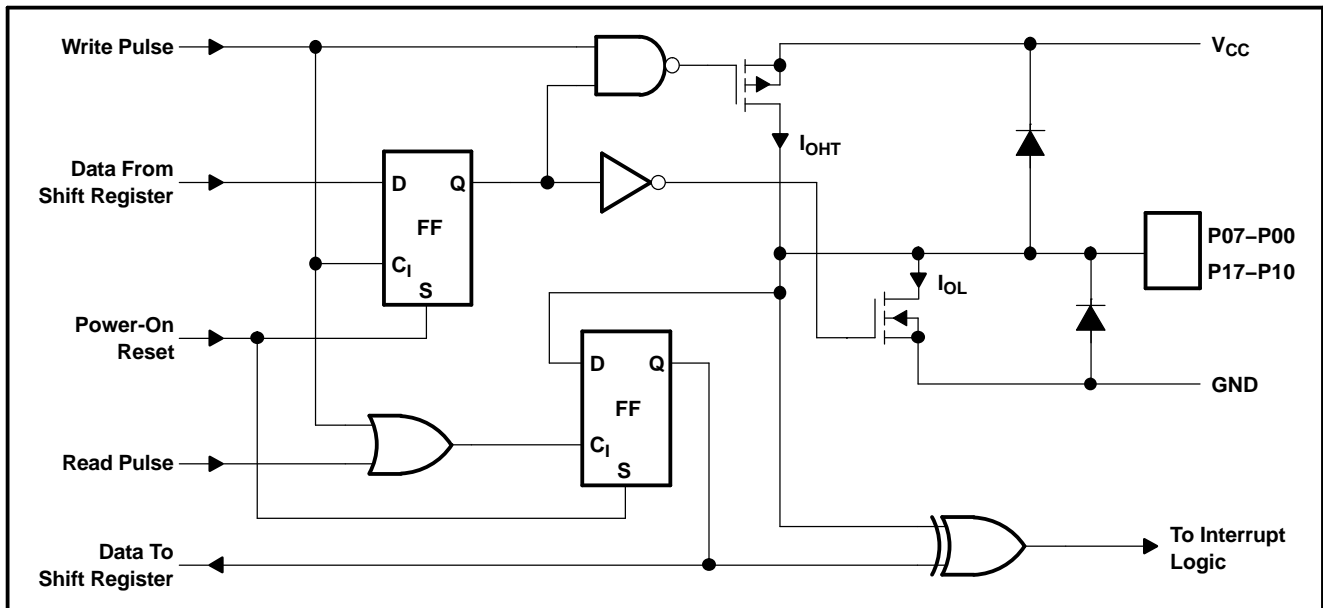

I²C INTERFACE

The bidirectional I²C bus consists of the serial clock (SCL) and serial data (SDA) lines. Both lines must be connected to a positive supply via a pullup resistor when connected to the output stages of a device. Data transfer may be initiated only when the bus is not busy.

I²C communication with this device is initiated by a master sending a start condition, a high-to-low transition on the SDA input/output while the SCL input is high (see Figure 1). After the start condition, the device address byte is sent, MSB first, including the data direction bit (R/W). This device does not respond to the general call address. After receiving the valid address byte, this device responds with an ACK, a low on the SDA input/output during the high of the ACK-related clock pulse. The address inputs (A2–A0) of the slave device must not be changed between the start and the stop conditions.

The data byte follows the address ACK. If the R/W bit is high, the data from this device are the values read from the P port. If the R/W bit is low, the data are from the master, to be output to the P port. The data byte is followed by an ACK sent from this device. If other data bytes are sent from the master, following the ACK, they are ignored by this device. Data are output only if complete bytes are received and acknowledged. The output data is valid at time (t_{pv}) after the low-to-high transition of SCL, during the clock cycle for the ACK.

On the I²C bus, only one data bit is transferred during each clock pulse. The data on the SDA line must remain stable during the high pulse of the clock period, as changes in the data line at this time are interpreted as control commands (start or stop) (see Figure 2).

A stop condition, a low-to-high transition on the SDA input/output while the SCL input is high, is sent by the master (see Figure 1).

The number of data bytes transferred between the start and the stop conditions from transmitter to receiver is not limited. Each byte of eight bits is followed by one ACK bit. The transmitter must release the SDA line before the receiver can send an ACK bit.

A slave receiver that is addressed must generate an ACK after the reception of each byte. Also, a master must generate an ACK after the reception of each byte that has been clocked out of the slave transmitter. The device that acknowledges has to pull down the SDA line during the ACK clock pulse so that the SDA line is stable low during the high pulse of the ACK-related clock period (see Figure 3). Setup and hold times must be taken into account.

A master receiver must signal an end of data to the transmitter by not generating an acknowledge (NACK) after the last byte that has been clocked out of the slave. This is done by the master receiver by holding the SDA line high. In this event, the transmitter must release the data line to enable the master to generate a stop condition.

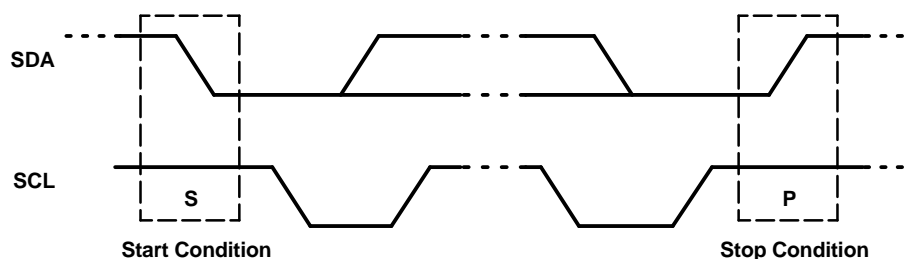

Figure 1. Definition of Start and Stop Conditions

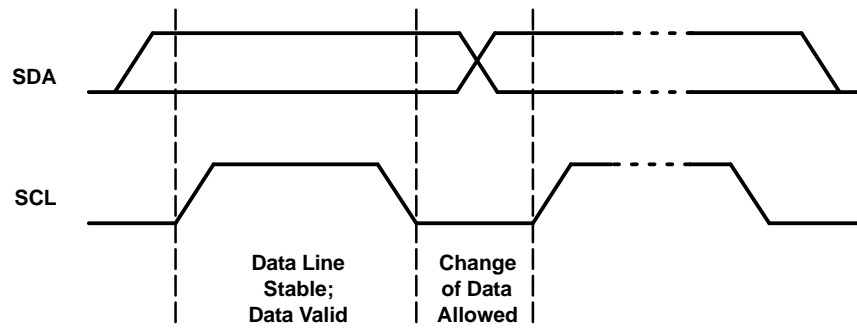

Figure 2. Bit Transfer

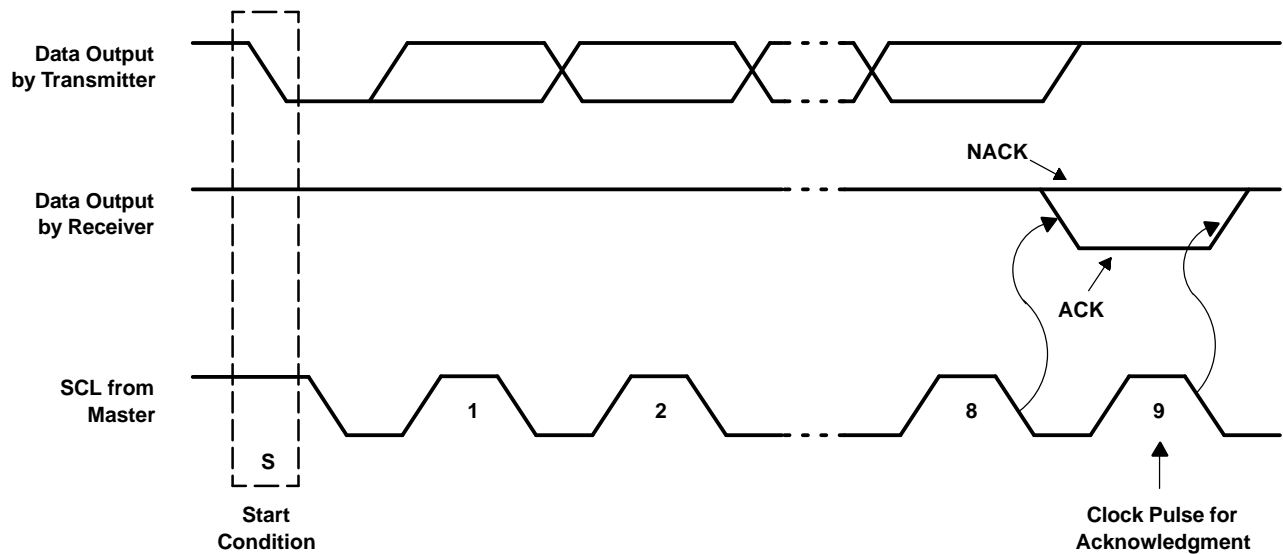

Figure 3. Acknowledgement on I²C Bus

INTERFACE DEFINITION TABLE

BYTE	BIT							
	7 (MSB)	6	5	4	3	2	1	0 (LSB)
I ² C slave address	L	H	L	L	A2	A1	A0	R/W
P0x I/O data bus	P07	P06	P05	P04	P03	P02	P01	P00
P1x I/O data bus	P17	P16	P15	P14	P13	P12	P11	P10

Figure 4 and Figure 5 show the address and timing diagrams for the write and read modes, respectively.

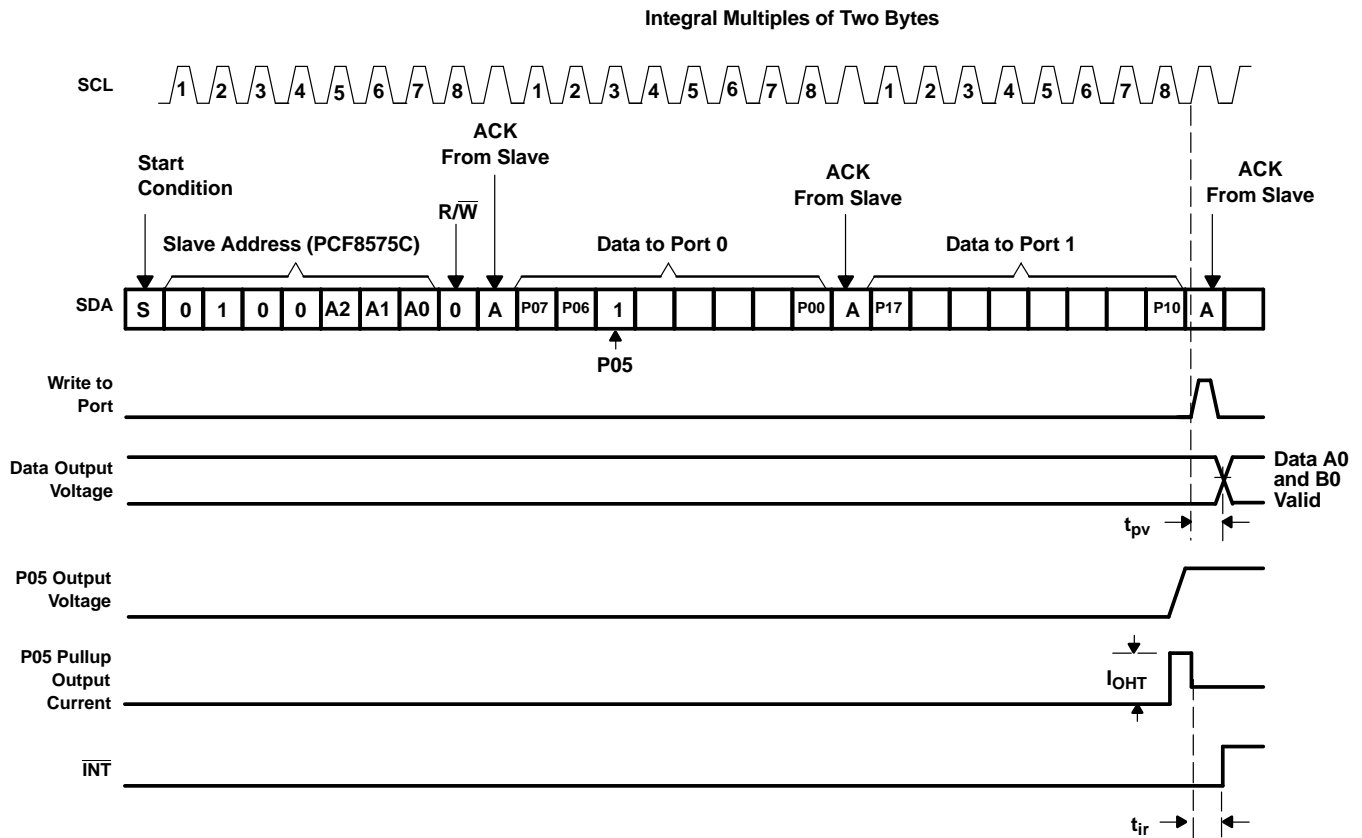
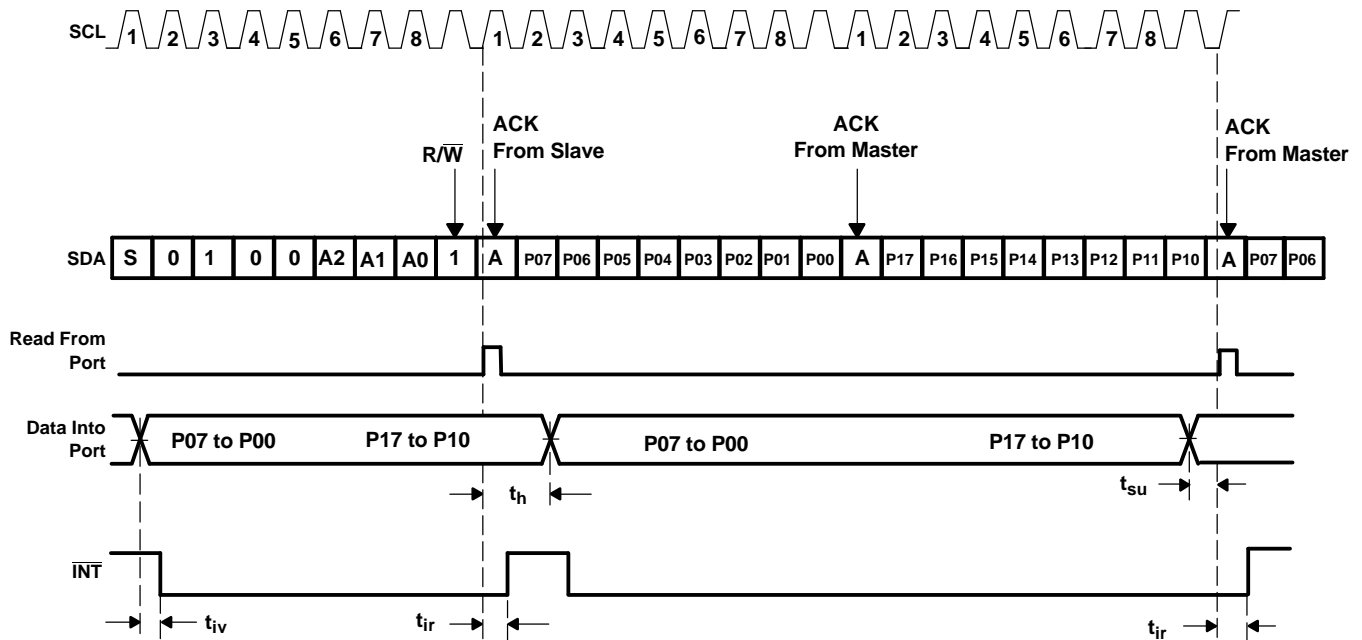

Figure 4. Write Mode (Output)

PCF8575C
REMOTE 16-BIT I²C AND SMBus LOW-POWER I/O EXPANDER
WITH INTERRUPT OUTPUT

SCPS123A—MARCH 2005—REVISED SEPTEMBER 2005



A low-to-high transition of SDA while SCL is high is defined as the stop condition (P). The transfer of data can be stopped at any moment by a stop condition. When this occurs, data present at the latest ACK phase is valid (output mode). Input data is lost.

Figure 5. Read Mode (Input)

ADDRESS REFERENCE TABLE

INPUTS			I ² C BUS SLAVE ADDRESS
A2	A1	A0	
L	L	L	32 (decimal), 20 (hexadecimal)
L	L	H	33 (decimal), 21 (hexadecimal)
L	H	L	34 (decimal), 22 (hexadecimal)
L	H	H	35 (decimal), 23 (hexadecimal)
H	L	L	36 (decimal), 24 (hexadecimal)
H	L	H	37 (decimal), 25 (hexadecimal)
H	H	L	38 (decimal), 26 (hexadecimal)
H	H	H	39 (decimal), 27 (hexadecimal)

Absolute Maximum Ratings⁽¹⁾

over operating free-air temperature range (unless otherwise noted)

		MIN	MAX	UNIT
V _{CC}	Supply voltage range	–0.5	6.5	V
V _I	Input voltage range ⁽²⁾	–0.5	V _{CC} + 0.5	V
V _O	Output voltage range ⁽²⁾	–0.5	V _{CC} + 0.5	V
I _{IK}	Input clamp current	V _I < 0		–20 mA
I _{OK}	Output clamp current	V _O < 0		–20 mA
I _{OK}	Input/output clamp current	V _O < 0 or V _O > V _{CC}		±400 μA
I _{OL}	Continuous output low current	V _O = 0 to V _{CC}		50 mA
I _{OH}	Continuous output high current	V _O = 0 to V _{CC}		–4 mA
Continuous current through V _{CC} or GND				±100 mA
θ _{JA}	Package thermal impedance ⁽³⁾	DB package		63
		DBQ package		61
		DGV package		86
		DW package		46
		PW package		88
		RGE package		53
		RHL package		43
T _{stg}	Storage temperature range	–65	150	°C

- (1) Stresses beyond those listed under "absolute maximum ratings" may cause permanent damage to the device. These are stress ratings only, and functional operation of the device at these or any other conditions beyond those indicated under "recommended operating conditions" is not implied. Exposure to absolute-maximum-rated conditions for extended periods may affect device reliability.
- (2) The input negative-voltage and output voltage ratings may be exceeded if the input and output current ratings are observed.
- (3) The package thermal impedance is calculated in accordance with JESD 51-7.

Recommended Operating Conditions

		MIN	MAX	UNIT
V _{CC}	Supply voltage	4.5	5.5	V
V _{IH}	High-level input voltage	A0, A1, A2, SDA, and SCL		0.7 × V _{CC} V _{CC} + 0.5
		P07–P00 and P17–P10		0.8 × V _{CC} V _{CC} + 0.5
V _{IL}	Low-level input voltage	A0, A1, A2, SDA, and SCL		–0.5 0.3 × V _{CC}
		P07–P00 and P17–P10		–0.5 0.6 × V _{CC}
I _{OHT}	P-port transient pullup current			–10 mA
I _{OL}	P-port low-level output current			25 mA
T _A	Operating free-air temperature	–40	85	°C

PCF8575C

REMOTE 16-BIT I²C AND SMBus LOW-POWER I/O EXPANDER WITH INTERRUPT OUTPUT

SCPS123A–MARCH 2005–REVISED SEPTEMBER 2005

Electrical Characteristics

over recommended operating free-air temperature range (unless otherwise noted)

PARAMETER		TEST CONDITIONS	V _{CC}	MIN	TYP ⁽¹⁾	MAX	UNIT
V _{IK}	Input diode clamp voltage	I _I = -18 mA	4.5 V to 5.5 V	-1.2			V
V _{POR}	Power-on reset voltage ⁽²⁾	V _I = V _{CC} or GND, I _O = 0	V _{POR}		1.2	1.8	V
I _{OHT}	P-port transient pullup current	High during ACK V _{OH} = GND	4.5 V	-0.5	-1		mA
I _{OL}	SDA	V _{OL} = 0.4 V	4.5 V to 5.5 V	3			mA
	P port	V _{OL} = 0.4 V	4.5 V to 5.5 V	5	15		
		V _{OL} = 1 V			10	25	
	$\overline{\text{INT}}$	V _{OL} = 0.4 V	4.5 V to 5.5 V	1.6			
I _I	SCL, SDA	V _I = V _{CC} or GND	4.5 V to 5.5 V			±2	μA
	A0, A1, A2					±1	
I _{IHL}	P port	V _I ≥ V _{CC} or V _I ≤ GND	4.5 V to 5.5 V			±400	μA
I _{CC}	Operating mode	V _I = V _{CC} or GND, I _O = 0, f _{SCL} = 400 kHz	5.5 V		100	200	μA
	Standby mode	V _I = V _{CC} or GND, I _O = 0, f _{SCL} = 0 kHz			2.5	10	
ΔI _{CC}	Supply current increase	One input at V _{CC} - 0.6 V, Other inputs at V _{CC} or GND	4.5 V to 5.5 V			200	μA
C _i	SCL	V _I = V _{CC} or GND	4.5 V to 5.5 V		3	7	pF
C _{io}	SDA	V _{IO} = V _{CC} or GND	4.5 V to 5.5 V		3	7	pF
	P port				4	10	

(1) All typical values are at V_{CC} = 5 V, T_A = 25°C.

(2) The power-on reset circuit resets the I²C bus logic with V_{CC} < V_{POR} and sets all I/Os to logic high (with current source to V_{CC}).

I²C Interface Timing Requirements

over recommended operating free-air temperature range (unless otherwise noted) (see Figure 6)

		MIN	MAX	UNIT
f _{scl}	I ² C clock frequency		400	kHz
t _{sch}	I ² C clock high time	0.6		μs
t _{scl}	I ² C clock low time	1.3		μs
t _{sp}	I ² C spike time		50	ns
t _{sds}	I ² C serial-data setup time	100		ns
t _{sdh}	I ² C serial-data hold time	0		ns
t _{icr}	I ² C input rise time	20 + 0.1C _b ⁽¹⁾	300	ns
t _{icf}	I ² C input fall time	20 + 0.1C _b ⁽¹⁾	300	ns
t _{ocf}	I ² C output fall time (10-pF to 400-pF bus)		300	ns
t _{buf}	I ² C bus free time between stop and start	1.3		μs
t _{sts}	I ² C start or repeated start condition setup	0.6		μs
t _{sth}	I ² C start or repeated start condition hold	0.6		μs
t _{sps}	I ² C stop condition setup	0.6		μs
t _{vd}	Valid-data time	SCL low to SDA output valid	1.2	μs
C _b	I ² C bus capacitive load		400	pF

(1) C_b = total bus capacitance of one bus line in pF

Switching Characteristics

over recommended operating free-air temperature range, $C_L \leq 100$ pF (unless otherwise noted) (see [Figure 7](#) and [Figure 8](#))

PARAMETER		FROM (INPUT)	TO (OUTPUT)	MIN	MAX	UNIT
t_{IV}	Interrupt valid time	P port	\overline{INT}		4	μ s
t_{IR}	Interrupt reset delay time	SCL	\overline{INT}		4	μ s
t_{PV}	Output data valid	SCL	P port		4	μ s
t_{SU}	Input data setup time	P port	SCL	0		μ s
t_H	Input data hold time	P port	SCL	4		μ s

TYPICAL OPERATING CHARACTERISTICS

$T_A = 25^\circ\text{C}$ (unless otherwise noted)

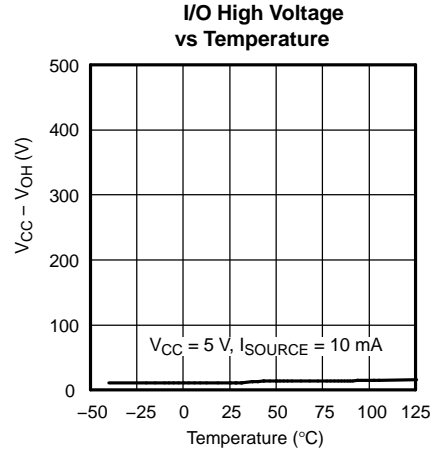
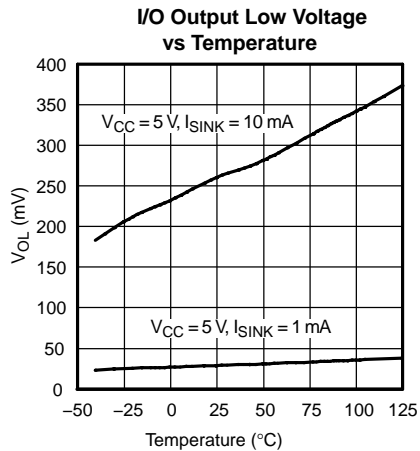
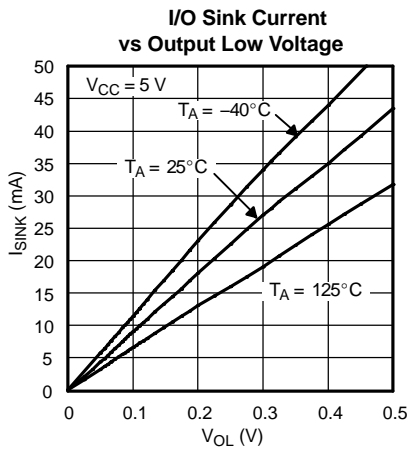
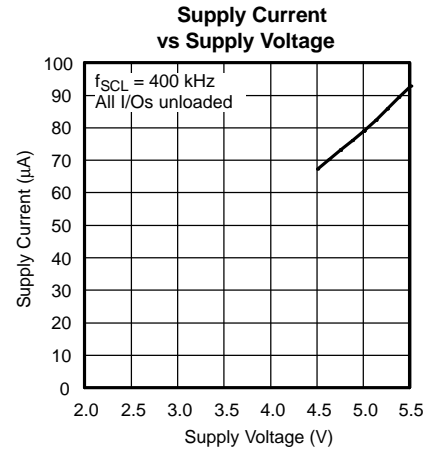
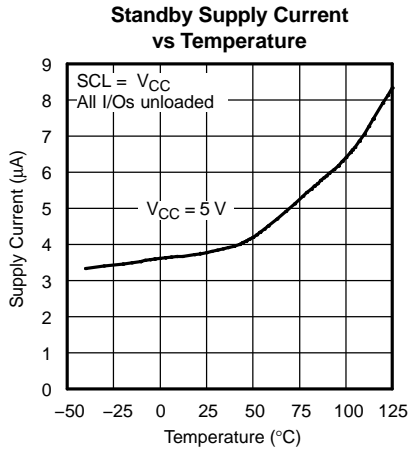
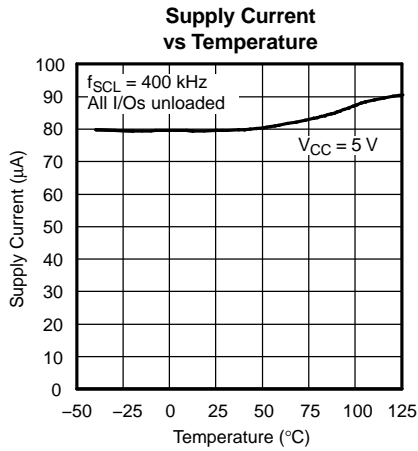

PARAMETER MEASUREMENT INFORMATION

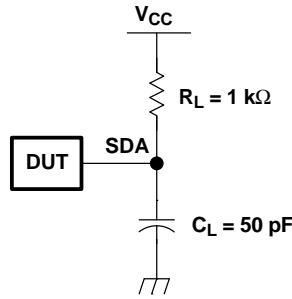

SDA LOAD CONFIGURATION

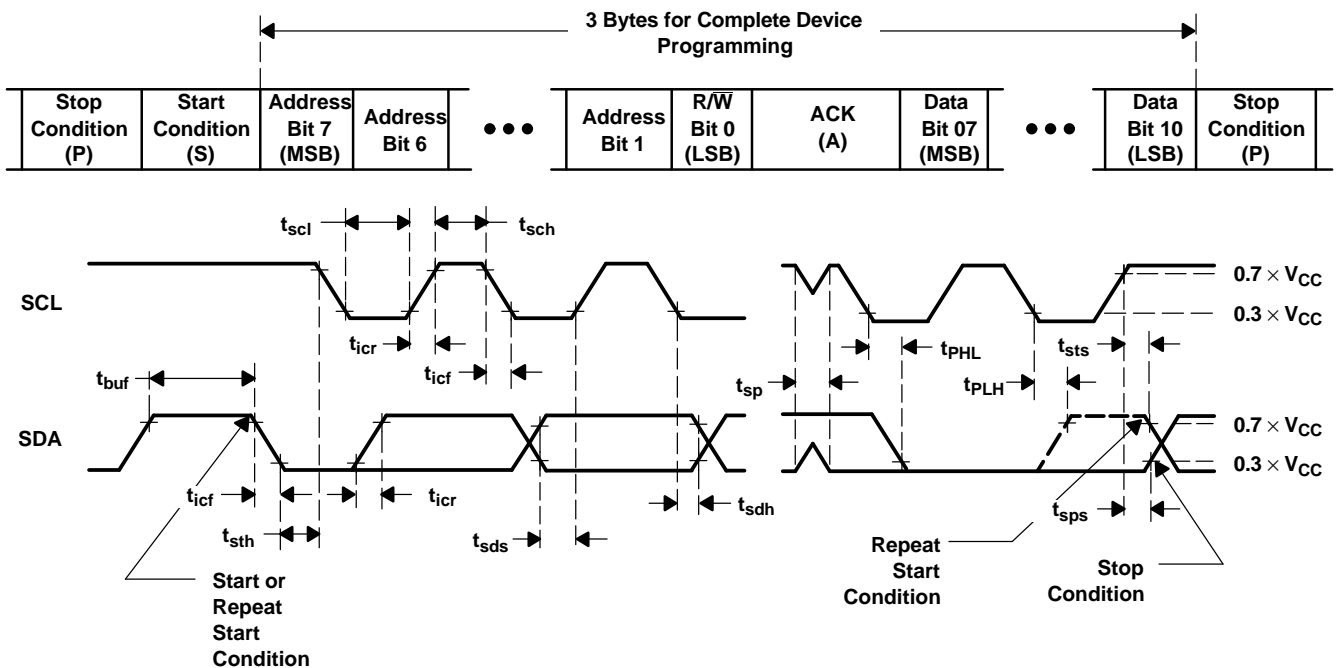

VOLTAGE WAVEFORMS

BYTE	DESCRIPTION
1	I ² C address
2, 3	P-port data

Figure 6. I²C Interface Load Circuit and Voltage Waveforms

PARAMETER MEASUREMENT INFORMATION

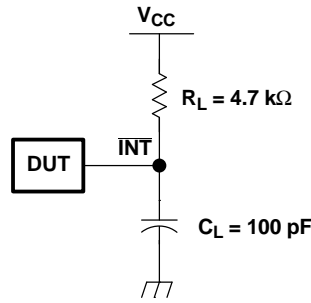

INTERRUPT LOAD CONFIGURATION

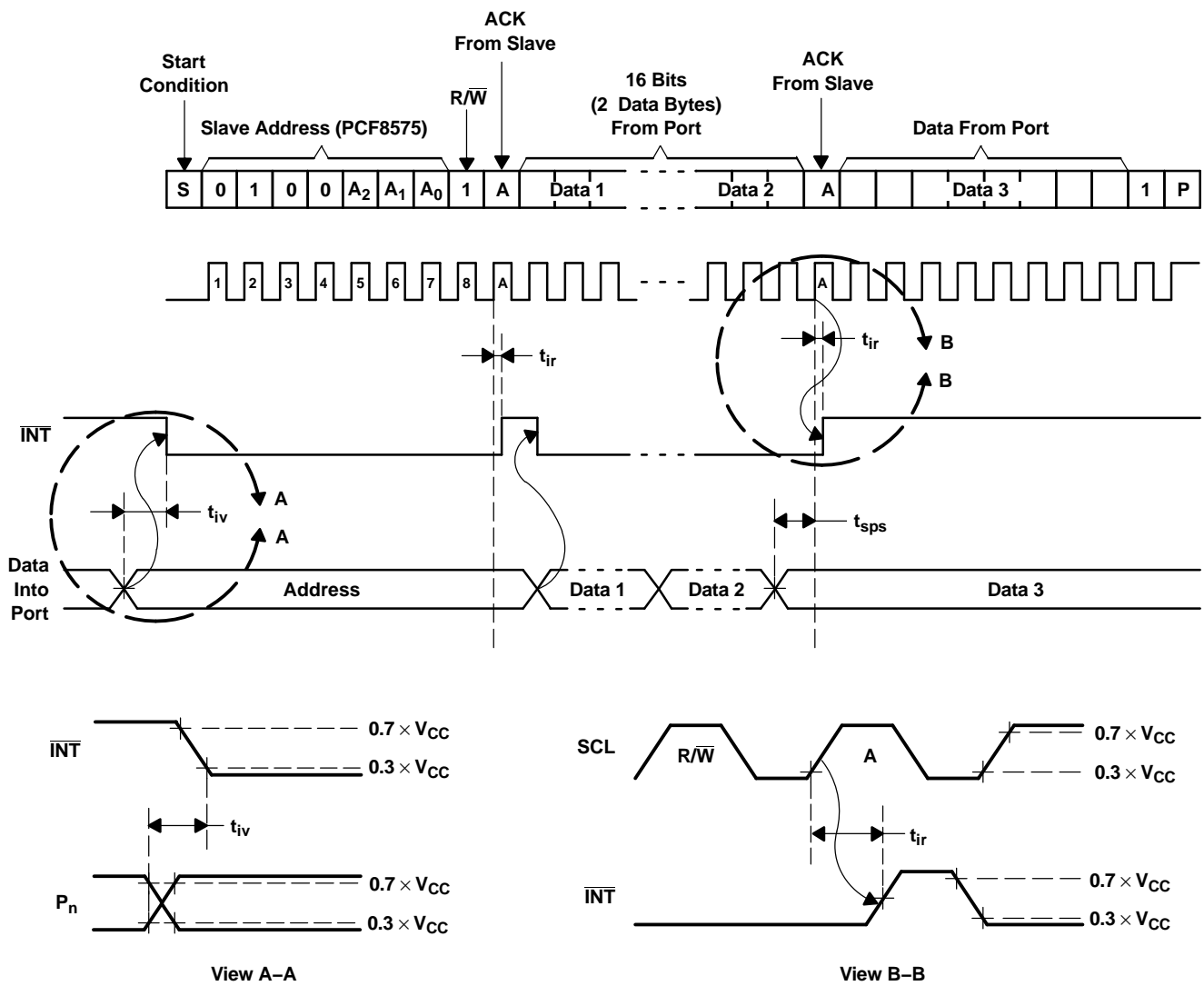

Figure 7. Interrupt Load Circuits and Voltage Waveforms

PARAMETER MEASUREMENT INFORMATION

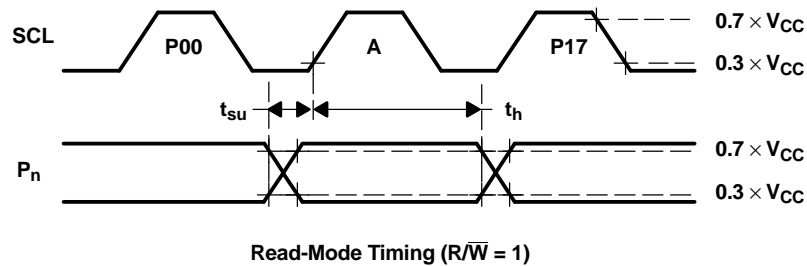
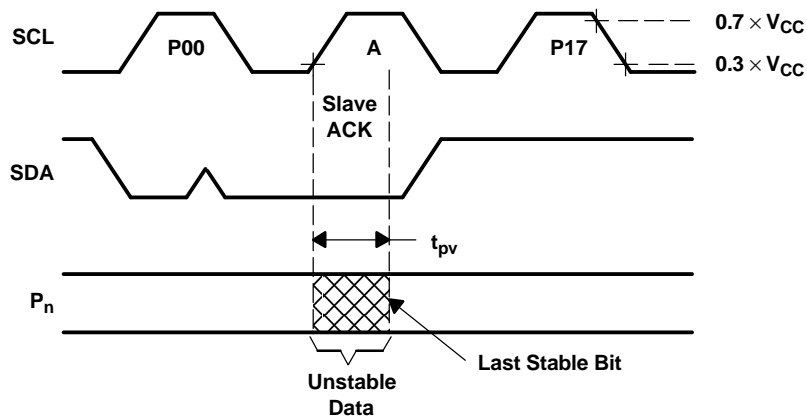
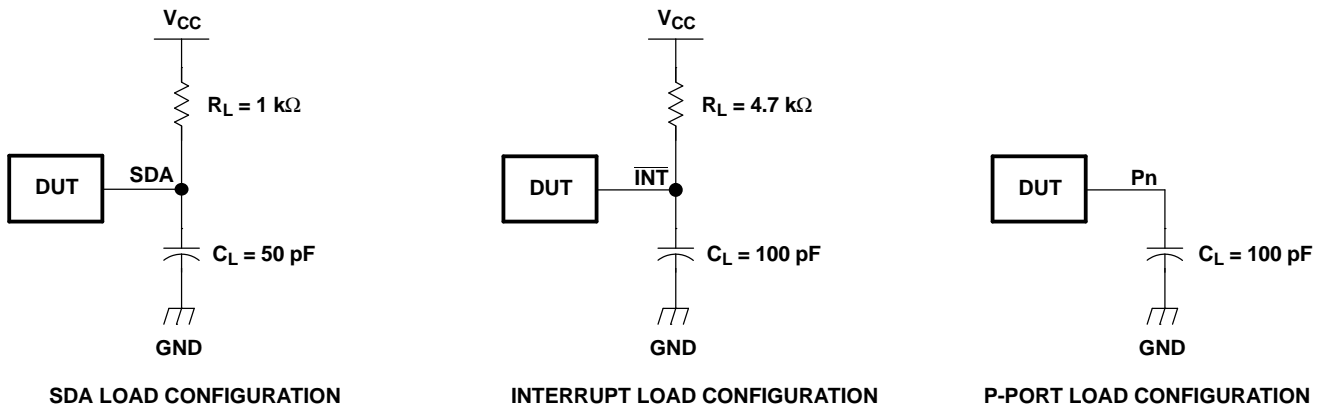

Figure 8. P-Port Timing Waveforms

THERMAL PAD MECHANICAL DATA
RGE (S-PQFP-N24)

THERMAL INFORMATION

This package incorporates an exposed thermal pad that is designed to be attached directly to an external heatsink. The thermal pad must be soldered directly to the printed circuit board (PCB), the PCB can be used as a heatsink. In addition, through the use of thermal vias, the thermal pad can be attached directly to a ground plane or special heatsink structure designed into the PCB. This design optimizes the heat transfer from the integrated circuit (IC).

For information on the Quad Flatpack No-Lead (QFN) package and its advantages, refer to Application Report, Quad Flatpack No-Lead Logic Packages, Texas Instruments Literature No. SCBA017. This document is available at www.ti.com.

The exposed thermal pad dimensions for this package are shown in the following illustration.

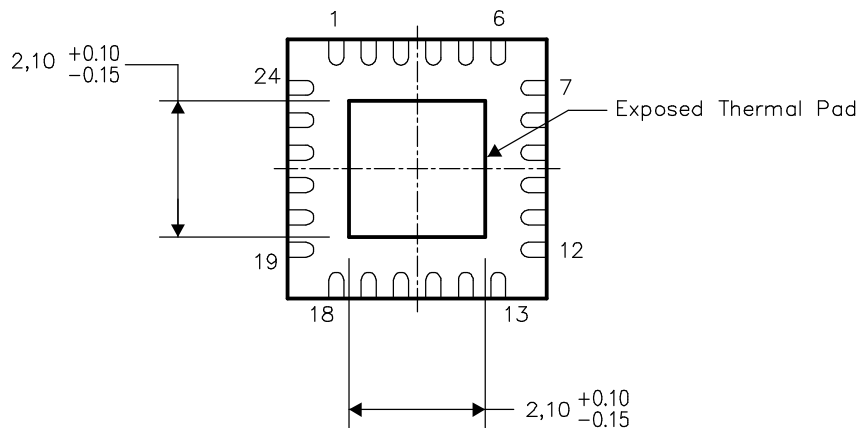

Bottom View

NOTE: All linear dimensions are in millimeters

Exposed Thermal Pad Dimensions

THERMAL PAD MECHANICAL DATA
RHL (S-PQFP-N24)

THERMAL INFORMATION

This package incorporates an exposed thermal pad that is designed to be attached directly to an external heatsink. The thermal pad must be soldered directly to the printed circuit board (PCB), the PCB can be used as a heatsink. In addition, through the use of thermal vias, the thermal pad can be attached directly to a ground plane or special heatsink structure designed into the PCB. This design optimizes the heat transfer from the integrated circuit (IC).

For information on the Quad Flatpack No-Lead (QFN) package and its advantages, refer to Application Report, Quad Flatpack No-Lead Logic Packages, Texas Instruments Literature No. SCBA017. This document is available at www.ti.com.

The exposed thermal pad dimensions for this package are shown in the following illustration.

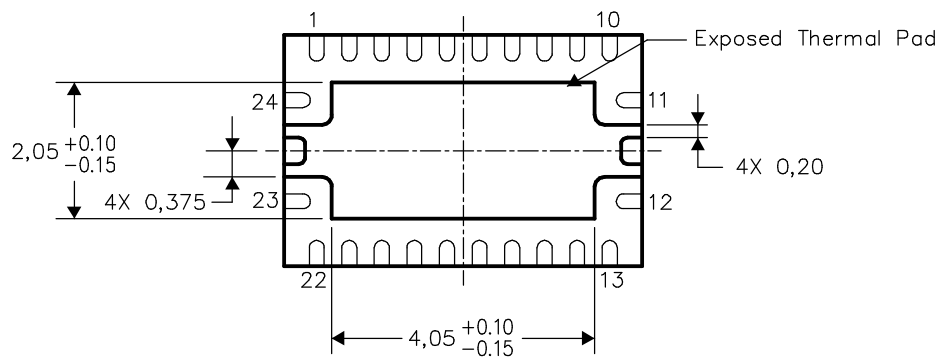

Bottom View

NOTE: All linear dimensions are in millimeters

Exposed Thermal Pad Dimensions

PACKAGING INFORMATION

Orderable Device	Status ⁽¹⁾	Package Type	Package Drawing	Pins	Package Qty	Eco Plan ⁽²⁾	Lead/Ball Finish	MSL Peak Temp ⁽³⁾
PCF8575CDB	ACTIVE	SSOP	DB	24	60	Green (RoHS & no Sb/Br)	CU NIPDAU	Level-1-260C-UNLIM
PCF8575CDBE4	ACTIVE	SSOP	DB	24	60	Green (RoHS & no Sb/Br)	CU NIPDAU	Level-1-260C-UNLIM
PCF8575CDBQR	ACTIVE	SSOP/ QSOP	DBQ	24	2500	Green (RoHS & no Sb/Br)	CU NIPDAU	Level-2-260C-1YEAR
PCF8575CDBQRE4	ACTIVE	SSOP/ QSOP	DBQ	24	2500	Green (RoHS & no Sb/Br)	CU NIPDAU	Level-2-260C-1YEAR
PCF8575CDBR	ACTIVE	SSOP	DB	24	2000	Green (RoHS & no Sb/Br)	CU NIPDAU	Level-1-260C-UNLIM
PCF8575CDBRE4	ACTIVE	SSOP	DB	24	2000	Green (RoHS & no Sb/Br)	CU NIPDAU	Level-1-260C-UNLIM
PCF8575CDGVR	ACTIVE	TVSOP	DGV	24	2000	Green (RoHS & no Sb/Br)	CU NIPDAU	Level-1-260C-UNLIM
PCF8575CDGVRE4	ACTIVE	TVSOP	DGV	24	2000	Green (RoHS & no Sb/Br)	CU NIPDAU	Level-1-260C-UNLIM
PCF8575CDW	ACTIVE	SOIC	DW	24	25	Green (RoHS & no Sb/Br)	CU NIPDAU	Level-1-260C-UNLIM
PCF8575CDWE4	ACTIVE	SOIC	DW	24	25	Green (RoHS & no Sb/Br)	CU NIPDAU	Level-1-260C-UNLIM
PCF8575CDWR	ACTIVE	SOIC	DW	24	2000	Green (RoHS & no Sb/Br)	CU NIPDAU	Level-1-260C-UNLIM
PCF8575CDWRE4	ACTIVE	SOIC	DW	24	2000	Green (RoHS & no Sb/Br)	CU NIPDAU	Level-1-260C-UNLIM
PCF8575CPW	ACTIVE	TSSOP	PW	24	60	Green (RoHS & no Sb/Br)	CU NIPDAU	Level-1-260C-UNLIM
PCF8575CPWE4	ACTIVE	TSSOP	PW	24	60	Green (RoHS & no Sb/Br)	CU NIPDAU	Level-1-260C-UNLIM
PCF8575CPWR	ACTIVE	TSSOP	PW	24	2000	Green (RoHS & no Sb/Br)	CU NIPDAU	Level-1-260C-UNLIM
PCF8575CPWRE4	ACTIVE	TSSOP	PW	24	2000	Green (RoHS & no Sb/Br)	CU NIPDAU	Level-1-260C-UNLIM

⁽¹⁾ The marketing status values are defined as follows:

ACTIVE: Product device recommended for new designs.

LIFEBUY: TI has announced that the device will be discontinued, and a lifetime-buy period is in effect.

NRND: Not recommended for new designs. Device is in production to support existing customers, but TI does not recommend using this part in a new design.

PREVIEW: Device has been announced but is not in production. Samples may or may not be available.

OBSELETE: TI has discontinued the production of the device.

⁽²⁾ Eco Plan - The planned eco-friendly classification: Pb-Free (RoHS) or Green (RoHS & no Sb/Br) - please check <http://www.ti.com/productcontent> for the latest availability information and additional product content details.

TBD: The Pb-Free/Green conversion plan has not been defined.

Pb-Free (RoHS): TI's terms "Lead-Free" or "Pb-Free" mean semiconductor products that are compatible with the current RoHS requirements for all 6 substances, including the requirement that lead not exceed 0.1% by weight in homogeneous materials. Where designed to be soldered at high temperatures, TI Pb-Free products are suitable for use in specified lead-free processes.

Green (RoHS & no Sb/Br): TI defines "Green" to mean Pb-Free (RoHS compatible), and free of Bromine (Br) and Antimony (Sb) based flame retardants (Br or Sb do not exceed 0.1% by weight in homogeneous material)

⁽³⁾ MSL, Peak Temp. -- The Moisture Sensitivity Level rating according to the JEDEC industry standard classifications, and peak solder temperature.

Important Information and Disclaimer:The information provided on this page represents TI's knowledge and belief as of the date that it is provided. TI bases its knowledge and belief on information provided by third parties, and makes no representation or warranty as to the accuracy of such information. Efforts are underway to better integrate information from third parties. TI has taken and continues to take reasonable steps to provide representative and accurate information but may not have conducted destructive testing or chemical analysis on incoming materials and chemicals. TI and TI suppliers consider certain information to be proprietary, and thus CAS numbers and other limited information may not be available for release.

In no event shall TI's liability arising out of such information exceed the total purchase price of the TI part(s) at issue in this document sold by TI to Customer on an annual basis.

DGV (R-PDSO-G**)

PLASTIC SMALL-OUTLINE

24 PINS SHOWN



- NOTES: A. All linear dimensions are in millimeters.
 B. This drawing is subject to change without notice.
 C. Body dimensions do not include mold flash or protrusion, not to exceed 0,15 per side.
 D. Falls within JEDEC: 24/48 Pins – MO-153
 14/16/20/56 Pins – MO-194

DW (R-PDSO-G24)

PLASTIC SMALL-OUTLINE PACKAGE

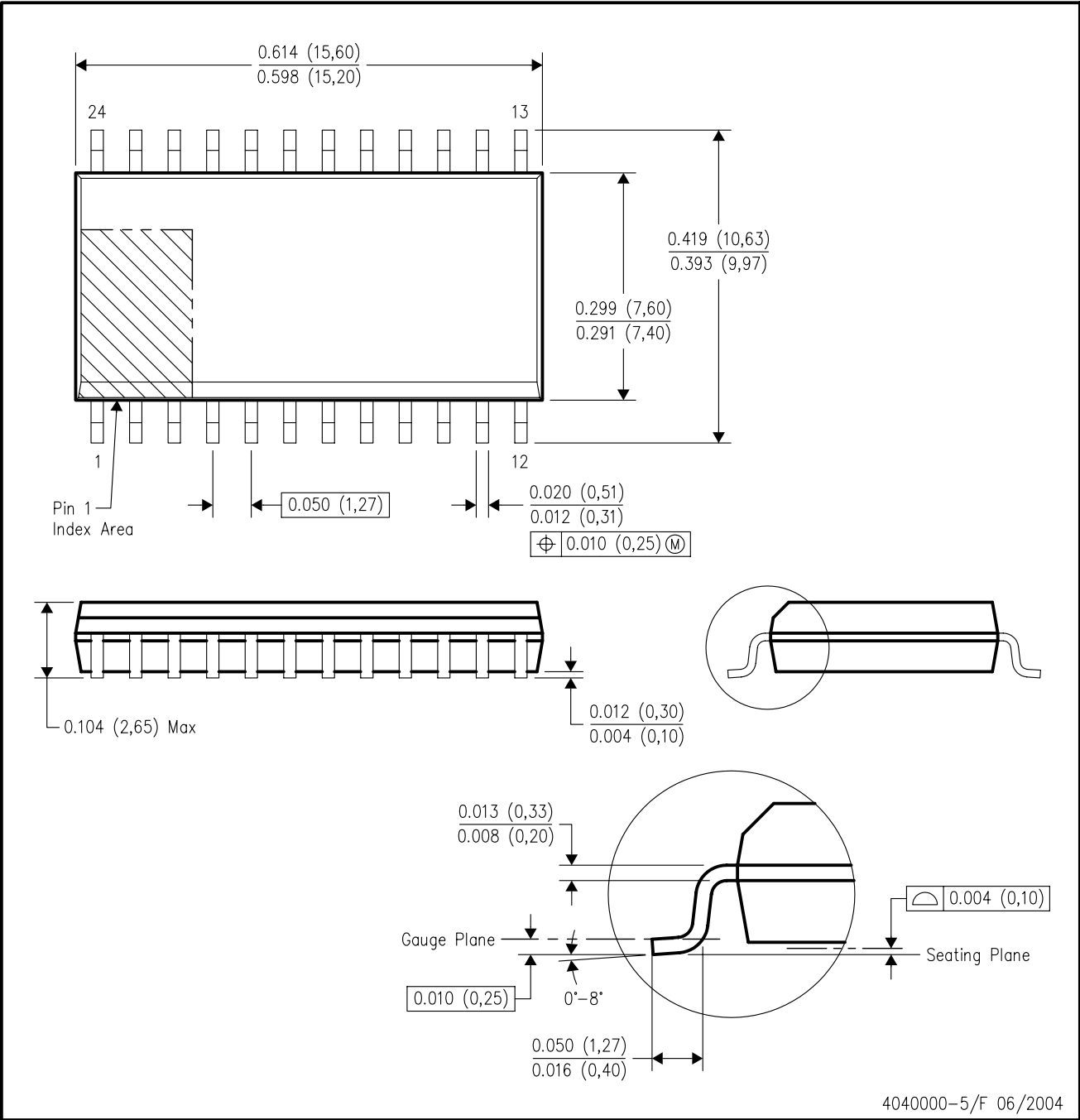

- NOTES:
- A. All linear dimensions are in inches (millimeters).
 - B. This drawing is subject to change without notice.
 - C. Body dimensions do not include mold flash or protrusion not to exceed 0.006 (0,15).
 - D. Falls within JEDEC MS-013 variation AD.

DBQ (R-PDSO-G24)

PLASTIC SMALL-OUTLINE PACKAGE

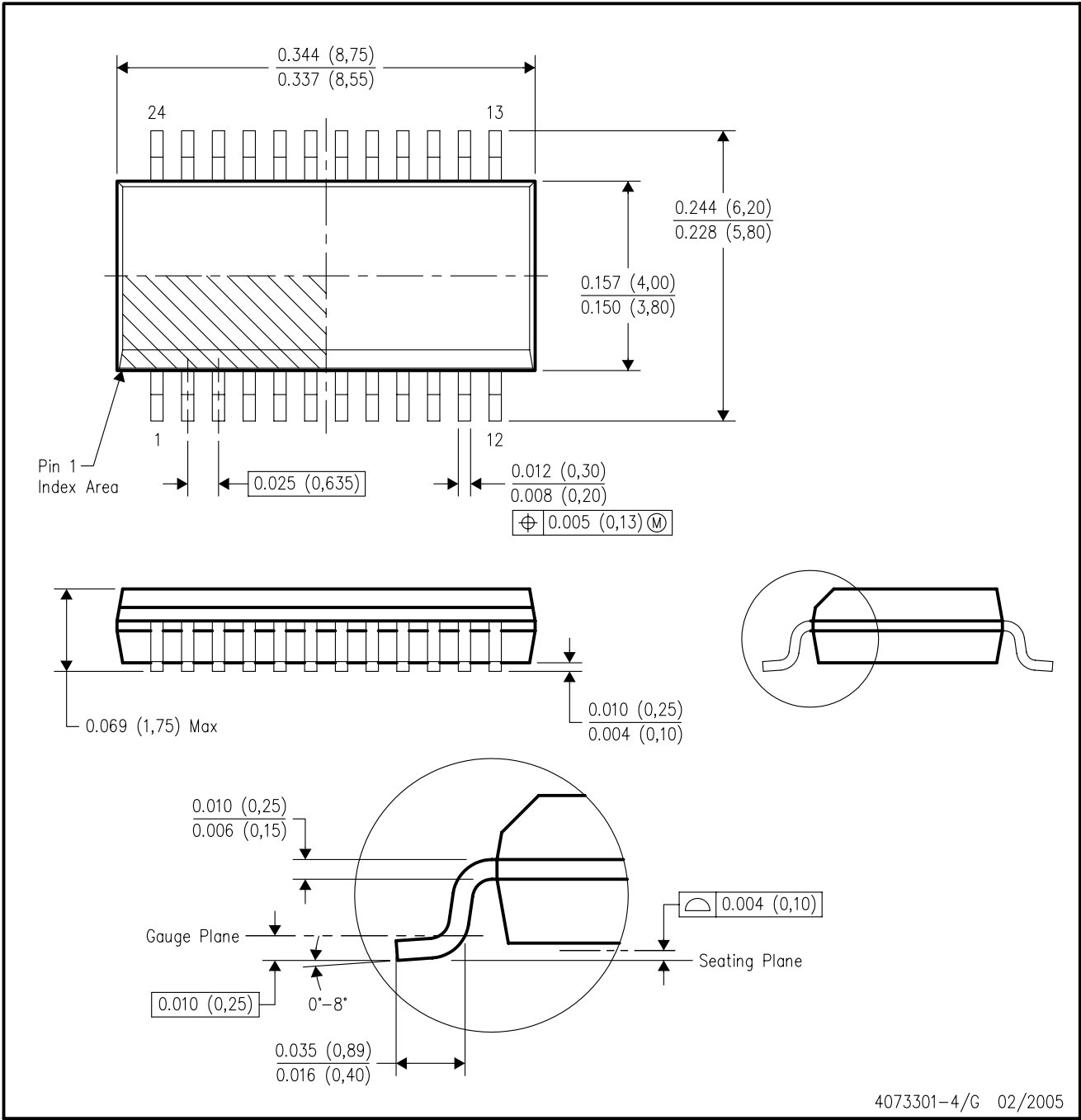

- NOTES:
- A. All linear dimensions are in inches (millimeters).
 - B. This drawing is subject to change without notice.
 - C. Body dimensions do not include mold flash or protrusion not to exceed 0.006 (0,15) per side.
 - D. Falls within JEDEC MO-137 variation AE.

DB (R-PDSO-G**)

PLASTIC SMALL-OUTLINE

28 PINS SHOWN

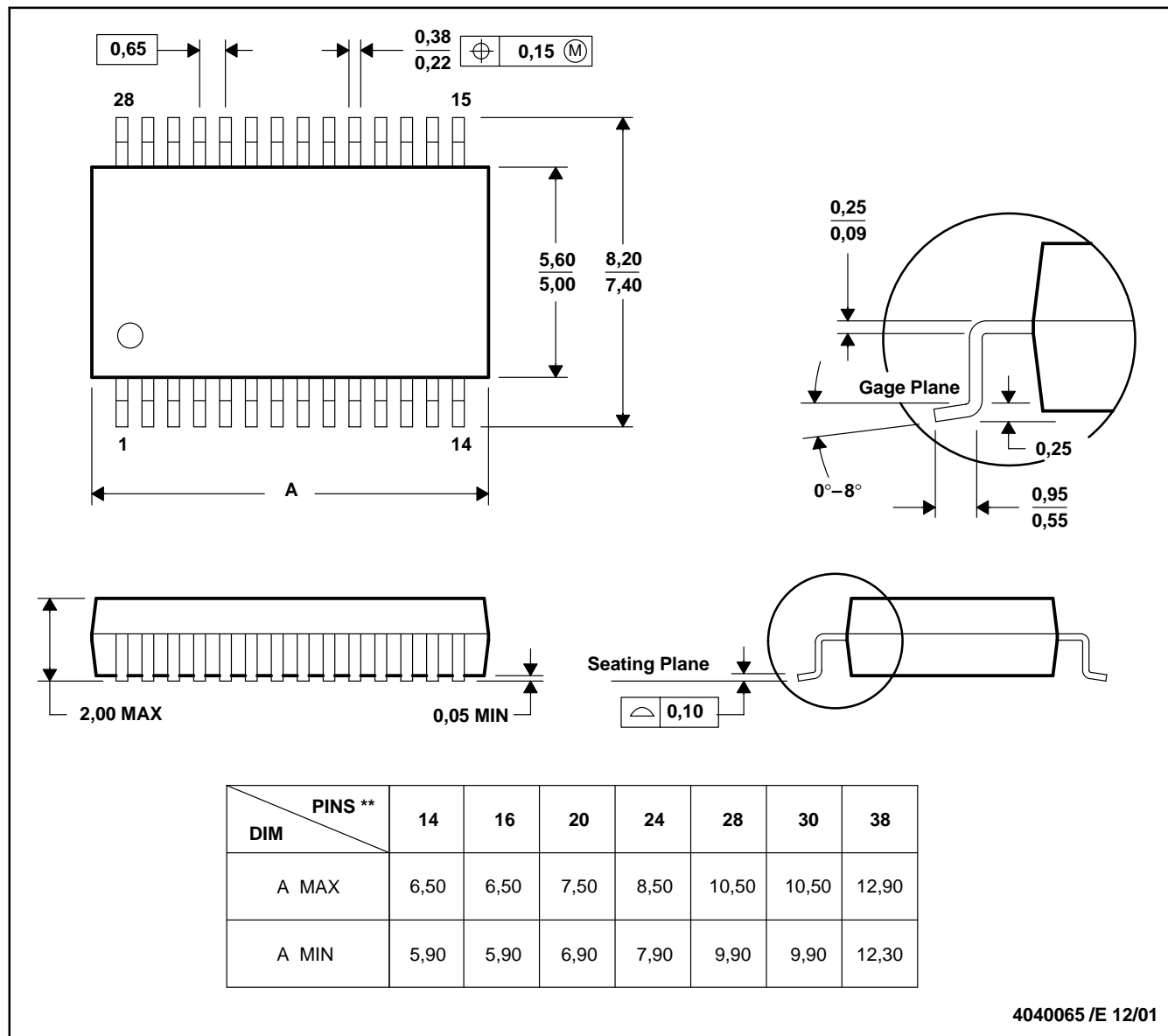

4040065 /E 12/01

- NOTES: A. All linear dimensions are in millimeters.
 B. This drawing is subject to change without notice.
 C. Body dimensions do not include mold flash or protrusion not to exceed 0,15.
 D. Falls within JEDEC MO-150

PW (R-PDSO-G**)

PLASTIC SMALL-OUTLINE PACKAGE

14 PINS SHOWN



4040064/F 01/97

- NOTES: A. All linear dimensions are in millimeters.
 B. This drawing is subject to change without notice.
 C. Body dimensions do not include mold flash or protrusion not to exceed 0,15.
 D. Falls within JEDEC MO-153

IMPORTANT NOTICE

Texas Instruments Incorporated and its subsidiaries (TI) reserve the right to make corrections, modifications, enhancements, improvements, and other changes to its products and services at any time and to discontinue any product or service without notice. Customers should obtain the latest relevant information before placing orders and should verify that such information is current and complete. All products are sold subject to TI's terms and conditions of sale supplied at the time of order acknowledgment.

TI warrants performance of its hardware products to the specifications applicable at the time of sale in accordance with TI's standard warranty. Testing and other quality control techniques are used to the extent TI deems necessary to support this warranty. Except where mandated by government requirements, testing of all parameters of each product is not necessarily performed.

TI assumes no liability for applications assistance or customer product design. Customers are responsible for their products and applications using TI components. To minimize the risks associated with customer products and applications, customers should provide adequate design and operating safeguards.

TI does not warrant or represent that any license, either express or implied, is granted under any TI patent right, copyright, mask work right, or other TI intellectual property right relating to any combination, machine, or process in which TI products or services are used. Information published by TI regarding third-party products or services does not constitute a license from TI to use such products or services or a warranty or endorsement thereof. Use of such information may require a license from a third party under the patents or other intellectual property of the third party, or a license from TI under the patents or other intellectual property of TI.

Reproduction of information in TI data books or data sheets is permissible only if reproduction is without alteration and is accompanied by all associated warranties, conditions, limitations, and notices. Reproduction of this information with alteration is an unfair and deceptive business practice. TI is not responsible or liable for such altered documentation.

Resale of TI products or services with statements different from or beyond the parameters stated by TI for that product or service voids all express and any implied warranties for the associated TI product or service and is an unfair and deceptive business practice. TI is not responsible or liable for any such statements.

Following are URLs where you can obtain information on other Texas Instruments products and application solutions:

Products		Applications	
Amplifiers	amplifier.ti.com	Audio	www.ti.com/audio
Data Converters	dataconverter.ti.com	Automotive	www.ti.com/automotive
DSP	dsp.ti.com	Broadband	www.ti.com/broadband
Interface	interface.ti.com	Digital Control	www.ti.com/digitalcontrol
Logic	logic.ti.com	Military	www.ti.com/military
Power Mgmt	power.ti.com	Optical Networking	www.ti.com/opticalnetwork
Microcontrollers	microcontroller.ti.com	Security	www.ti.com/security
		Telephony	www.ti.com/telephony
		Video & Imaging	www.ti.com/video
		Wireless	www.ti.com/wireless

Mailing Address: Texas Instruments
Post Office Box 655303 Dallas, Texas 75265