

**STRUCTURE** Silicon Monolithic Integrated Circuit  
**TYPE** Single Channel Series Regulator Driver IC  
**PRODUCT SERIES** **BD3520FVM**  
**FEATURES**

- Non Rush Current on Start up (NRCS)
- N channel MOSFET driver
- Output Voltage : 1.2V (±1%)

○ ABSOLUTE MAXIMUM RATINGS (Ta=25°C)

Parameter	Symbol	Limit	Unit
Supply Voltage	VCC	7 *1	V
Drain Voltage (VIN)	VD	7	V
Enable Input Voltage	Ven	7	V
Power Dissipation	Pd	437.5 *2	mW
Operating Temperature Range	Topr	-10~+100	°C
Storage Temperature Range	Tstg	-55~+150	°C
Maximum Junction Temperature	Tjmax	+150	°C

\*1 Operating temperature range should not exceed Tjmax=150°C

\*2 Pd derating at 3.5mW/°C for temperature above Ta=25°C

○ RECOMMENDED OPERATING CONDITIONS (Ta=25°C)

PARAMETER	SYMBOL	MIN	MAX	UNIT
Supply Voltage	VCC	4.5	5.5	V
Drain Voltage (VIN)	VD	1.2	5.5	V
Enable Input Voltage	Ven	-0.3	VCC	V
Capacitor on NRCS Terminal	CNRCS	0.001	1	uF

★ This product is not designed for protection against radioactive rays.

Status of this document

The Japanese version of this document is the official specification.

This translated version is intended only as a reference, to aid in understanding the official version.

If there are any differences between the original and translated versions of this document, the official Japanese language version takes priority.

## ○ ELECTRICAL CHARACTERISTICS

(Unless otherwise specified, Ta=25°C VCC=5V VIN=3.3V Ven=3V)

PARAMETER	SYMBOL	LIMIT			UNIT	CONDITIONS
		MIN	TYP	MAX		
Bias Current	ICC	-	0.85	1.7	mA	
Shut Down Mode Current	IST	-	0	10	uA	Ven=0V
Output Voltage 1	Vo1	1.188	1.200	1.212	V	Io=50mA
Output Voltage 2	Vo2	1.176	1.200	1.224	V	Vcc=4.5V to 5.5V , Ta=-10°C to 100°C
Line Regulation	Reg.I	-	0.1	0.5	%/V	VCC=4.5V to 5.5V
Load Regulation	Reg.L	-	0.5	10	mV	Io=0 to 3A
[Enable]						
High Level Enable Input Voltage	Enhi	2	-	Vcc	V	
Low Level Enable Input Voltage	Enlow	-0.3	-	0.8	V	
Enable pin Input Current	Ien	-	7	10	uA	Ven=3V
[Source Voltage]						
VS Input Bias Current	ISBIAS	-	1.2	2.4	mA	
VS Standby Current	ISSTB	150	-	-	mA	VS=1V Ven=0V
[Output MOSFET Driver]						
MOSFET Driver Source Current	IGSO	2	3	4	mA	VFB=1.1V, VGATE=2.5V
MOSFET Driver Sink Current	IGSI	2	3	4	mA	VFB=1.3V, VGATE=2.5V
[UVLO]						
VCC UVLO	VccUVLO	4.20	4.35	4.50	V	Vcc:Sweep up
VCC UVLO Hysteresis	Vchys	100	160	220	mV	Vcc:Sweep down
VD UVLO	VDUVLO	Vo×0.6	Vo×0.7	Vo×0.8	V	VD:Sweep up
[Drain Voltage Sensing]						
VD Input bias Current	Ivd	10	16	22	uA	
[NRCS/SCP]						
NRCS Charge Current	Inrcs	14	20	26	uA	VNRCS=0.5V
SCP Charge Current	Iscpch	14	20	26	uA	VNRCS=0.5V
SCP Discharge Current	IscpDi	0.3	-	-	mA	VNRCS=0.5V
SCP Threshold Voltage	Vscp	1.2	1.3	1.4	V	
Short Detect Voltage	Voscp	Vo×0.3	Vo×0.35	Vo×0.4	V	
NRCS Stand-by Voltage	VSTB	-	-	50	mV	

○ PHYSICAL DIMENSIONS

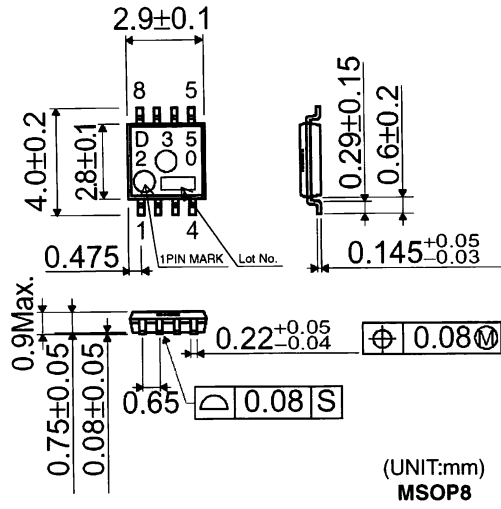

○ BLOCK DIAGRAM

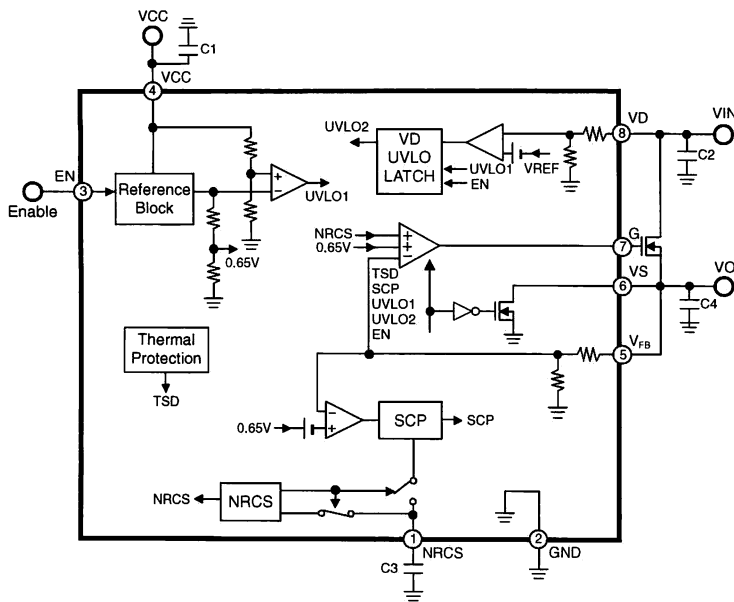

○ Pin number Pin name

PIN No.	PIN Name
1	NRCS
2	GND
3	EN
4	VCC
5	VFB
6	VS
7	G
8	VD

ONOTES FOR USE

- (1) Absolute maximum range  
Although the quality of this product is rigorously controlled, and circuit operation is guaranteed within the operation ambient temperature range, the device may be destroyed when applied voltage or operating temperature exceeds its absolute maximum rating. Because the failure mode (such as short mode or open mode) cannot be identified in this instance, it is important to take physical safety measures such as fusing if a specific mode in excess of absolute rating limits is considered for implementation.
- (2) Ground potential  
Make sure the potential for the GND pin is always kept lower than the potentials of all other pins, regardless of the operating mode, including transient conditions.
- (3) Thermal Design  
Provide sufficient margin in the thermal design to account for the allowable power dissipation (Pd) expected in actual use.
- (4) Using in the strong electromagnetic field  
Use in strong electromagnetic fields may cause malfunctions.
- (5) ASO  
Be sure that the output transistor for this IC does not exceed the absolute maximum ratings or ASO value.
- (6) Thermal Protection Circuit  
A thermal shutdown circuit (T.S.D) is built into the IC to prevent damage due to overheating. Therefore, all the outputs are turned off when the T.S.D circuit is activated. (This IC latches output to off mode when the temperature recedes to the specified level. To release latch mode, EN or UVLO is re-operated.) However, the T.S.D circuit is used only for extreme conditions, and the regulator circuit should still be designed for the IC not to exceed  $T_j(max)=150^{\circ}C$ .
- (7) GND pattern  
When both a small-signal GND and high current GND are present, single-point grounding (at the set standard point) is recommended, in order to separate the small-signal and high current patterns, and to be sure the voltage change stemming from the wiring resistance and high current does not cause any voltage change in the small-signal GND. In the same way, care must be taken to avoid wiring pattern fluctuations in any connected external component GND.
- (8) Output Capacitor (C4)  
Mount an output capacitor between VS and GND for stability purposes. The output capacitor is for the open loop gain phase compensation and reduces the output voltage load regulation. If the capacitor value is not large enough, the output voltage may oscillate. And if the equivalent series resistance (ESR) is too large, the output voltage rise/drop increases during a sudden load change. A 220uF polymer capacitor is recommended. However, the stability depends on the characteristics of temperature, load, the gate capacitance of the external MOSFET, and the mutual conductance (gm). And if a small ESR capacitor such as a ceramic capacitor is utilized (several kind of capacitors are utilized in parallel), the output voltage may oscillate due to lack of phase margin. In this case, measures can be taken by adding a capacitor and a resistor in series with this capacitor between the gate of MOSFET and GND. Please confirm operation across a variety of temperature, load conditions, and MOSFET characteristics.
- (9) Input Capacitor (C1, C2)  
The input capacitor reduces the output impedance of the voltage supply source connected in the VCC and VIN. If the output impedance of this power supply increases, the input voltage (VCC,VIN) may become unstable. This may result in the output voltage oscillation or lowering ripple rejection. A low ESR 10uF capacitor with minimal susceptibility to temperature is preferable, but stability depends on power supply characteristics, the substrate wiring pattern, and the parasitic capacitor between Gate and Drain of MOSFET. Please confirm operation across a variety of temperature, load, and MOSFET conditions.
- (10) NRCS (Non Rush Current on Start-up) Setting(C3)  
The NRCS function is built in this IC to prevent rush current from going through the load (VIN to Vo) for start-up. The constant current comes from the NRCS pin when EN is high or UVLO function is deactivated. Temporary reference voltage is made proportional to time due to current charge the NRCS pin capacitor and make output voltage start up proportional to this reference volatge.  
Timer latch short circuit protection function is built in this IC (NRCS is also working at the same time.) to protect the breakdown of the power MOSFET caused by rush current when the output is shorted to GND. This function becomes active when the output voltage level goes under by 30% of specified Vout. The constant current comes from the NRCS pin in this case. When the reference voltage made by the current charge of the NRCS pin hits 1.3V (Typ.), the gate voltage becomes low. To obtain a stable SCP delay time, a capacitor (B) with susceptibility to temperature is recommended.
- (11) Input Terminal (VCC,VD,EN)  
The EN, VD, and VCC are isolated. The UVLO protects incorrect operation when the voltage level of VD and VCC are low. The output becomes high when these pins reach the individual threshold level independent of the start-up pin order. However, if VIN shut down while the IC works under the normal operation, SCP function becomes active and latches the status. And the output does not come back active even though VIN goes up high again. In this case, start VCC or EN up again to deactivate this latch function.
- (12) Maximum Output Current (Maximum Load)  
The maximum output current of the power supply utilizing the IC depends on external MOSFET. The MOSFET should be chosen based on a required power supply characteristics for an actual application.
- (13) Please add a protection diode when a large inductance component is connected to the output terminal, and reverse-polarity power is possible at startup or in output OFF condition.

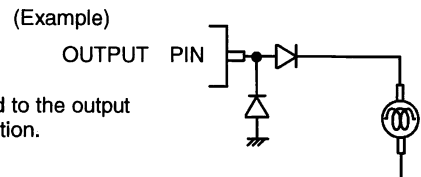

### Notes

- No technical content pages of this document may be reproduced in any form or transmitted by any means without prior permission of ROHM CO.,LTD.
- The contents described herein are subject to change without notice. The specifications for the product described in this document are for reference only. Upon actual use, therefore, please request that specifications to be separately delivered.
- Application circuit diagrams and circuit constants contained herein are shown as examples of standard use and operation. Please pay careful attention to the peripheral conditions when designing circuits and deciding upon circuit constants in the set.
- Any data, including, but not limited to application circuit diagrams information, described herein are intended only as illustrations of such devices and not as the specifications for such devices. ROHM CO.,LTD. disclaims any warranty that any use of such devices shall be free from infringement of any third party's intellectual property rights or other proprietary rights, and further, assumes no liability of whatsoever nature in the event of any such infringement, or arising from or connected with or related to the use of such devices.
- Upon the sale of any such devices, other than for buyer's right to use such devices itself, resell or otherwise dispose of the same, no express or implied right or license to practice or commercially exploit any intellectual property rights or other proprietary rights owned or controlled by
- ROHM CO., LTD. is granted to any such buyer.
- Products listed in this document are no antiradiation design.

The products listed in this document are designed to be used with ordinary electronic equipment or devices (such as audio visual equipment, office-automation equipment, communications devices, electrical appliances and electronic toys).

Should you intend to use these products with equipment or devices which require an extremely high level of reliability and the malfunction of which would directly endanger human life (such as medical instruments, transportation equipment, aerospace machinery, nuclear-reactor controllers, fuel controllers and other safety devices), please be sure to consult with our sales representative in advance.

It is our top priority to supply products with the utmost quality and reliability. However, there is always a chance of failure due to unexpected factors. Therefore, please take into account the derating characteristics and allow for sufficient safety features, such as extra margin, anti-flammability, and fail-safe measures when designing in order to prevent possible accidents that may result in bodily harm or fire caused by component failure. ROHM cannot be held responsible for any damages arising from the use of the products under conditions out of the range of the specifications or due to non-compliance with the NOTES specified in this catalog.

Thank you for your accessing to ROHM product informations.

More detail product informations and catalogs are available, please contact your nearest sales office.

**ROHM** Customer Support System

THE AMERICAS / EUROPE / ASIA / JAPAN

[www.rohm.com](http://www.rohm.com)

Contact us : [webmaster@rohm.co.jp](mailto:webmaster@rohm.co.jp)