

Specifications

1

MODEL	165/20	210/30	245/35	250/35	350/40	500/50	500/50T	750/80 1PH	750/80 3PH	1000/120 3PH
INPUT SUPPLY 400V 50HZ	/	/	/	/	/	/	/	/	30A	50A
MAX. START CURRENT	165A	210A	250	250A	350A	500A	500A	750A	750A	1000A
CHARGE RATE SETTINGS	Max Min	Maximum - Medium - Minimum							5	
DUTY CYCLE (STARTING)	INTERMITTENT (5 SECONDS ON - 1 MINUTE OFF - MAX. 5 CYCLES)									
CHARGE PROTECTION	THERMOSTAT WITH AUTOMATIC RESET									
STANDARD ACCESSORIES	CHARGING LEADS WITH CROCODILE CLIPS					CHARGING LEADS AND REMOTE CONTROL FOR BOOST START				
TIMER CHARGER	/	/	/	/	/	/	/	120 MINUTES		

CONNECTION TO THE MAINS

IMPORTANT: The wires in the mains leads are coloured according to the following code:

WIRE COLOUR	1 PH MODELS	3 PH MODELS
BROWN	Live	Phase 1
BLUE	Neutral	Phase 2
BLACK	/	Phase 3
GREEN & YELLOW	Earth	Earth

WARNING: This appliance must be earthed.

Safety / Operating Instructions

SAFETY FIRST:

- Batteries should only be charged in a well ventilated area, and away from naked flames.
- During charging the battery can emit explosive gases and care must be taken to prevent sparks and flames.
- Prevent explosion, ensure all vent caps are removed before charging.
- Be aware of the dangers of battery acid.
- Eye protection should be worn when working with battery acid.
- Check you know where the eye wash station is located before working with acid. Should you get acid in your eyes, rinse immediately with sterile water and seek medical advise.
- Wash hands thoroughly after working with batteries.
- Battery acid will damage clothing. It is advised to wear a rubber apron, gloves and boots when dealing with battery acid.

ONLY USE ON LEAD ACID BATTERIES, DO NOT ATTEMPT TO CHARGE NON RE-CHARGEABLE BATTERIES

PRE-CHARGING OPERATIONS:

Disconnect battery terminal clamps. Clean thoroughly the terminal poles to ensure a good contact can be achieved.

Remove the vent caps. Ensure the battery acid level is correct (approx. 5 - 10mm above the interior cells). Top up with distilled water if necessary. Do not over fill.

The condition of the battery can be checked by measuring the electrolyte specific gravity. This can be done by use of a hydrometer. Assuming the electrolyte temperature is 25° the following table can be used as a guide.

SPECIFIC GRAVITY	DEGREE BAUME	CONDITION OF BATTERY
1.26	29.7	CHARGED
1.20	24.0	SEMI FLAT
1.14	17.7	FLAT

Before connecting the charger to the battery always ensure the charger is disconnected from the mains power supply.

BATTERY CHARGING (165/20 – 210/30 – 245/35 - 250/35 – 350/40 – 500/50)

Ensure supply voltage to charger is correct.

Switch the main On/Off switch to Off.

According to the battery voltage connect the lead with the red clamp to the terminal marked '+12V' or '+24V' on the charger. This is not necessary on model 165/20 as both leads are already connected.

Now with the charger still switched Off. Connect the red clamp to the positive (+) side of the battery, and the black clamp to the negative (-) side of the battery. **Important: the connection to the earthed side of the battery should be made directly to the car body, away from the fuel line.**

Select the desired charge rate I.E. minimum, medium (where appropriate) and maximum.

Switch on the On/Off switch the pilot light will indicate power is 'on'.

NB: As a guide, use minimum setting on small car batteries up to 60AH, the medium setting for light commercial vehicle batteries and the maximum setting for large heavy duty batteries. However as the output current depends upon the charge state of the battery, check the ammeter when starting to charge. If the reading is in the red band section of the meter then switch to a lower charge rate. Should you leave the charger operating at too high a charge rate then the thermal cut out will operate. In this instance select a lower charge setting and wait approximately 10 minutes for the thermal cut out to automatically reset.

It is advisable to charge the battery at the lowest possible rate. As this will ensure a better charged battery. Charging a battery too quickly will reduce its life span.

BATTERY CHARGING (500/50T – 750/80 – 1000/120)

Ensure supply voltage to charger is correct.

Switch the main On/Off switch to Off.

According to the battery voltage connect the lead with the red clamp to the terminal marked '+12V' or '+24V' on the charger. This is not necessary on model 165/20 as both leads are already connected.

Now with the charger still switched Off. Connect the red clamp to the positive (+) side of the battery, and the black clamp to the negative (-) side of the battery. **Important: the connection to the earthed side of the battery should be made directly to the car body, away from the fuel line.**

- *Manual charge:* set the timer knob on "MANUAL CHARGE" (fully anticlockwise). Choose the desired rate of charge selecting the appropriate setting from MIN to MAX or from 1 (lowest) to 5 (highest) where applicable. Switch on the ON/OFF switch: the pilot light will indicate power is "ON" and the charging current will be indicated by the ammeter.

- *Timer charge:* set the timer knob on "CHARGE TIMER ON" then turn it clockwise until the desired time of charge is indicated (time scale is in minutes, max. charging time is 120 min.). Select the desired rate of charge as above and switch on the ON/OFF switch: the pilot light will indicate power is "ON" and the charging current will be indicated by the ammeter. Charge will stop automatically once the selected time has expired.

NOTE: The unit is also protected against inverted polarities connection and short circuiting the crocodile clips, by means of a fuse. Should this happen the fuse will need to be replaced.

BOOST START

Switch the main On/Off switch to Off.

Connect the leads to the charger as per the battery charging instructions.

The charger is connected to the battery whilst the battery is still connected to the vehicle.

The battery terminal NOT connected to the earth or chassis must be connected first.

Therefore connect the red clamp to the positive (+) side of the battery and connect the black clamp to the negative (-) side of the battery.

The connection to the earthed side of the battery should be made directly to the vehicle body, well away from the fuel line.

CARRY OUT THIS CONNECTION PROCEDURE WITH CARE!!

Turn the charge setting to maximum and switch on the On/Off switch. On models equipped with timer both "Manual Charge " or "Timer Charge" mode can be selected.

Observe the ammeter reading, wait until the charge current reduces approximately 50%. Then operate the vehicles ignition and immediately turn the setting switch from maximum to START.

If your charger/starter is equipped with a remote start this will enable you to operate the START switch whilst sitting in the vehicle ready to turn on the ignition: set the setting switch on "START" (or "Pos.6-START" where appropriate), plug the remote control connector into the three pin socket on the panel (remote control is permanently connected on model 500/50T): boost-start is now possible by operating the remote control trigger and the engine starter at the same time.

IF THE VEHICLE HAS NOT STARTED WITHIN 5 SECONDS SWITCH SETTING BACK FROM START TO MAXIMUM, AND TURN OFF THE MAIN SWITCH.

IMPORTANT: Boost start can only be operated for 5 seconds at a time and a period of 1 minute must elapse before retrying. This can be repeated up to 5 times there after you must wait a minimum of 10 minutes. However, should the engine not have started within the first 5 attempts then consideration must be given to other possible faults on the vehicle.

Persistence to ignore this instruction will damage the charger and invalidate any warranty.

AFTER CHARGING ALWAYS DISCONNECT THE CHARGER FROM THE MAINS SUPPLY BEFORE DISCONNECTION FROM THE BATTERY.

Parts Lists

MODEL 165/20 - 210/30 - 245/35 - 250/35 - 350/40 - 500/50 - 500/50T

165/20 - 210/30 - 245/35
 (FRONT VIEW ALSO FOR 250/35 - 350/40 -
 500/50 - 500/50T)

250/35 - 350/40
 500/50 - 500/50T

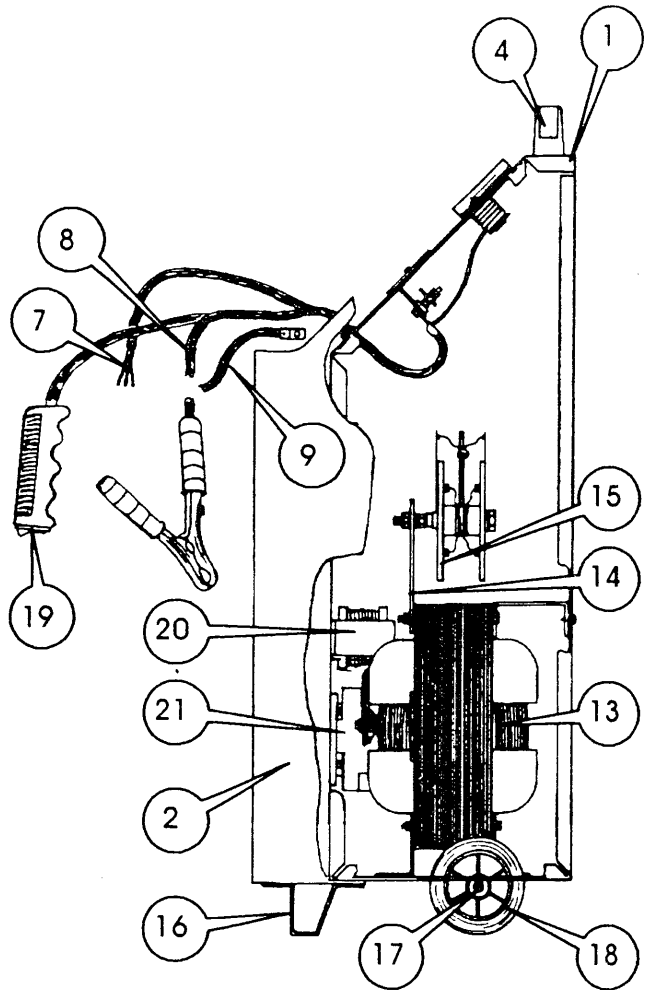
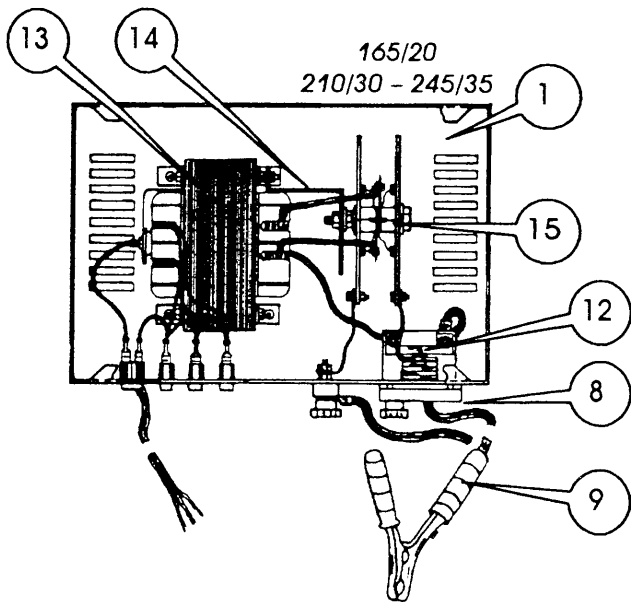
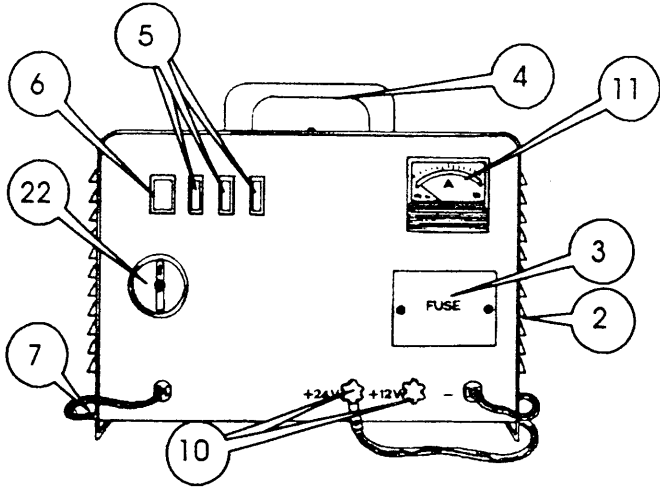

REF	DESCRIPTION	REF	DESCRIPTION
1	BASE	12	FUSE
2	LID	13	TRANSFORMER
3	FUSE COVER	14	RECTIFIER BRACKET
4	HANDLE	15	RECTIFIER
5	SELECTOR SWITCH(ES)	16	FOOT
6	MAINS SWITCH	17	AXLE
7	MAINS LEAD	18	WHEEL
8	NEGATIVE (-) CLAMP (BLACK)	19	REMOTE CONTROL
9	POSITIVE (+) CLAMP (RED)	20	AUXILIARY TRANSFORMER
10	POSITIVE TERMINAL	21	CONTACTOR
11	AMMETER	22	TIMER

Parts Lists

MODEL 750/80 - 1000/120

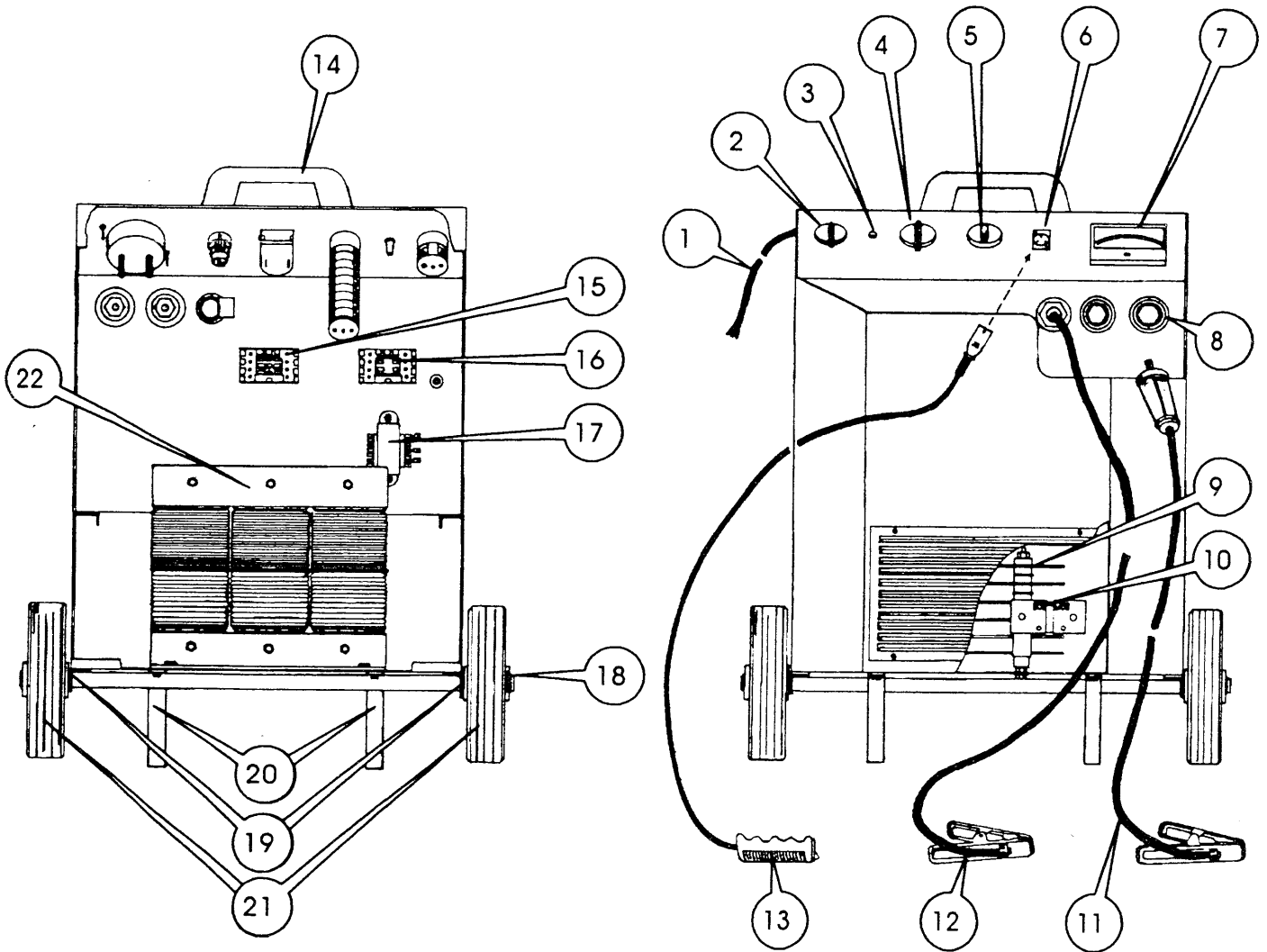

REF	DESCRIPTION	REF	DESCRIPTION
1	MAINS LEAD	12	NEGATIVE LEAD (BLACK CLAMP)
2	MAINS SWITCH	13	REMOTE CONTROL
3	PILOT LAMP	14	HANDLE
4	SELECTOR SWITCH	15	CHARGE CONTACTOR
5	TIMER	16	START CONTACTOR
6	REMOTE CONTROL SOCKET	17	AUXILIARY TRANSFORMER
7	AMMETER	18	AXLE
8	POSITIVE OUTPUT SOCKET	19	AXLE BRACKET
9	RECTIFIER	20	FOOT
10	FUSE	21	WHEEL
11	POSITIVE LEAD (RED CLAMP)	22	POWER TRANSFORMER

Assembly Instructions

7

MODEL 250/35 - 350/40 - 500/50 - 500/50T

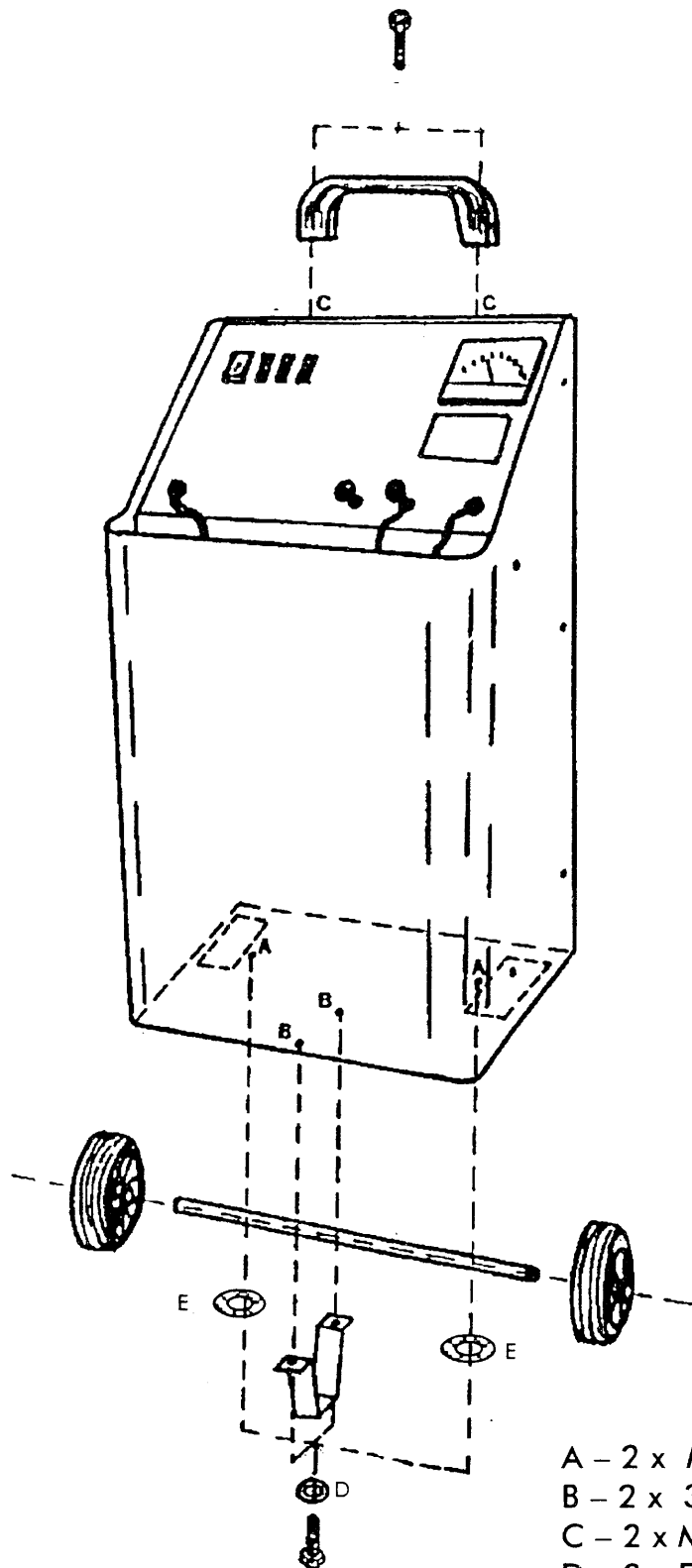

- A - 2 x M4x16 SCREWS
- B - 2 x 3.9x22 SCREWS
- C - 2 x M6x20 SCREWS
- D - 2 x D4 WASHERS
- E - 2 x D4 FAN DISC WASHERS

Assembly Instructions

8

MODEL 750/80 - 1000/120

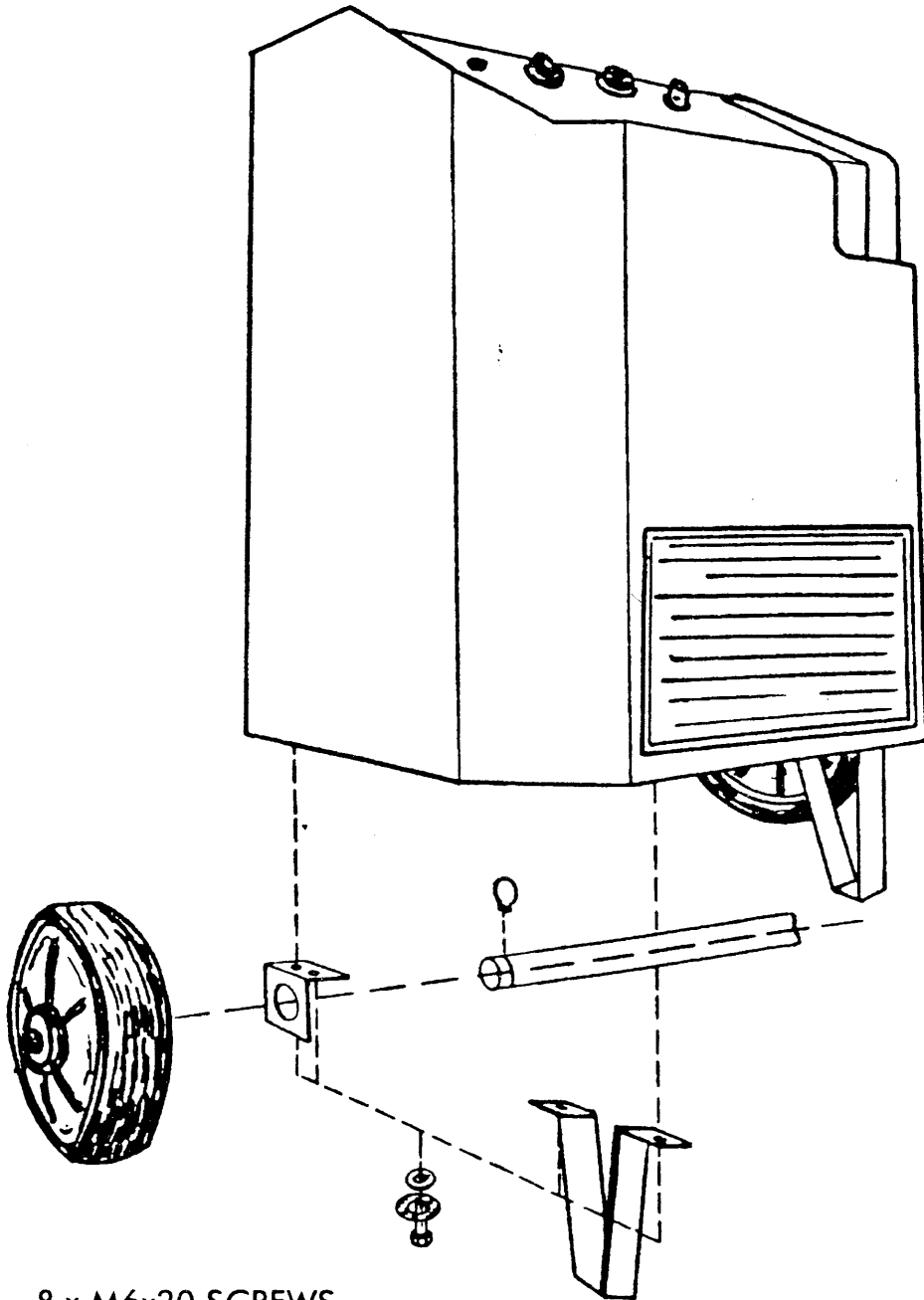

- 8 x M6x20 SCREWS
- 8 x D.6 WASHERS
- 8 x D.6 FAN DISC WASHERS

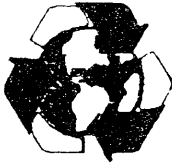

QUALITY AND ENVIRONMENT DEPARTMENT

SIP (INDUSTRIAL PRODUCTS) LTD

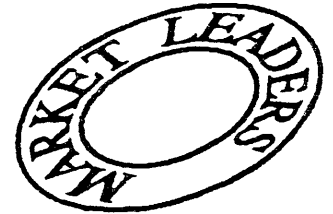

**Congratulations upon your new SIP purchase.
We thank you for having purchased SIP equipment**

All SIP equipment has been designed, manufactured, tested and quality controlled to be complete and free of manufacturing defects in order to provide long trouble free service.

In the unlikely event that difficulties should be experienced with your new purchase, please refer to the enclosed instruction manual prior to contacting the SIP stockist from which the purchase was made. If the stockist is unable to rectify the problem encountered, they will contact us directly on your behalf.

In order to solve your problem quickly, you will need to provide the following information.

- 1. Type and model of product purchased.**
- 2. Proof of purchase indicating date and supplier.**
- 3. Use for which product is tasked.**
- 4. Problem encountered.**

With this data we will always endeavour to find a prompt resolution.

ENVIRONMENT

We believe that the protection of the environment is of paramount importance, not only on a day to day basis but also for our future generations. Please take the time to read this and make yourself aware of the environmental issues related to the product which you have purchased so that you may also contribute towards the protection of our future.

1. Please dispose of the packaging for the product in a responsible manner. It is suitable for recycling. Help to protect the environment, take the packaging to your local amenity tip and place it in the appropriate recycling bin.
2. If the product you have purchased requires oil changes to be carried out as part of the normal maintenance schedule please ensure that the waste oil is disposed of in a responsible manner. Under Section 111 of the Water Industry Act 1991 it is an offence to contaminate a drain or public sewer with oil. Most local amenity tips have oil disposal facilities. Please use them.
3. When the product you have purchased has reached the end of its useful service life or if you dispose of it for another reason give consideration to the fact that the product does contain recyclable materials. Most local amenity tips have facilities to recycle these materials. Please use them.

Thank you for protecting the environment for yourself and future generations.