

## **MICRO compound table KT 70**

Made of solid aluminium with surface treatment and fitted with adjustable dovetail gibs and three T-slots of the MICROMOT standard (12 x 6 x 5mm). Adjustable ruler eases workpiece positioning. Both handwheels have zero-resettable dials with graduations indicating 1 revolution = 1.0mm and 1 division = 0.05mm. The clamps and securing bolts for the MB 140/S and TBM are included.

### **General details:**

Table size 200 x 70mm. X travel 134mm and Y travel 46mm, maximum height 43mm.

No 27 100

### **Step clamps made of steel**

The step clamps set is supplied with the KT 70, but can also be ordered separately. Set consists of 2 ea. stepped blocks and clamps, T-slot nuts of the MICROMOT standard (11.5 x 11 x 4mm), bolts. This set also fits the mill/lathe systems PD 230/E and PD 400.

No 24 256

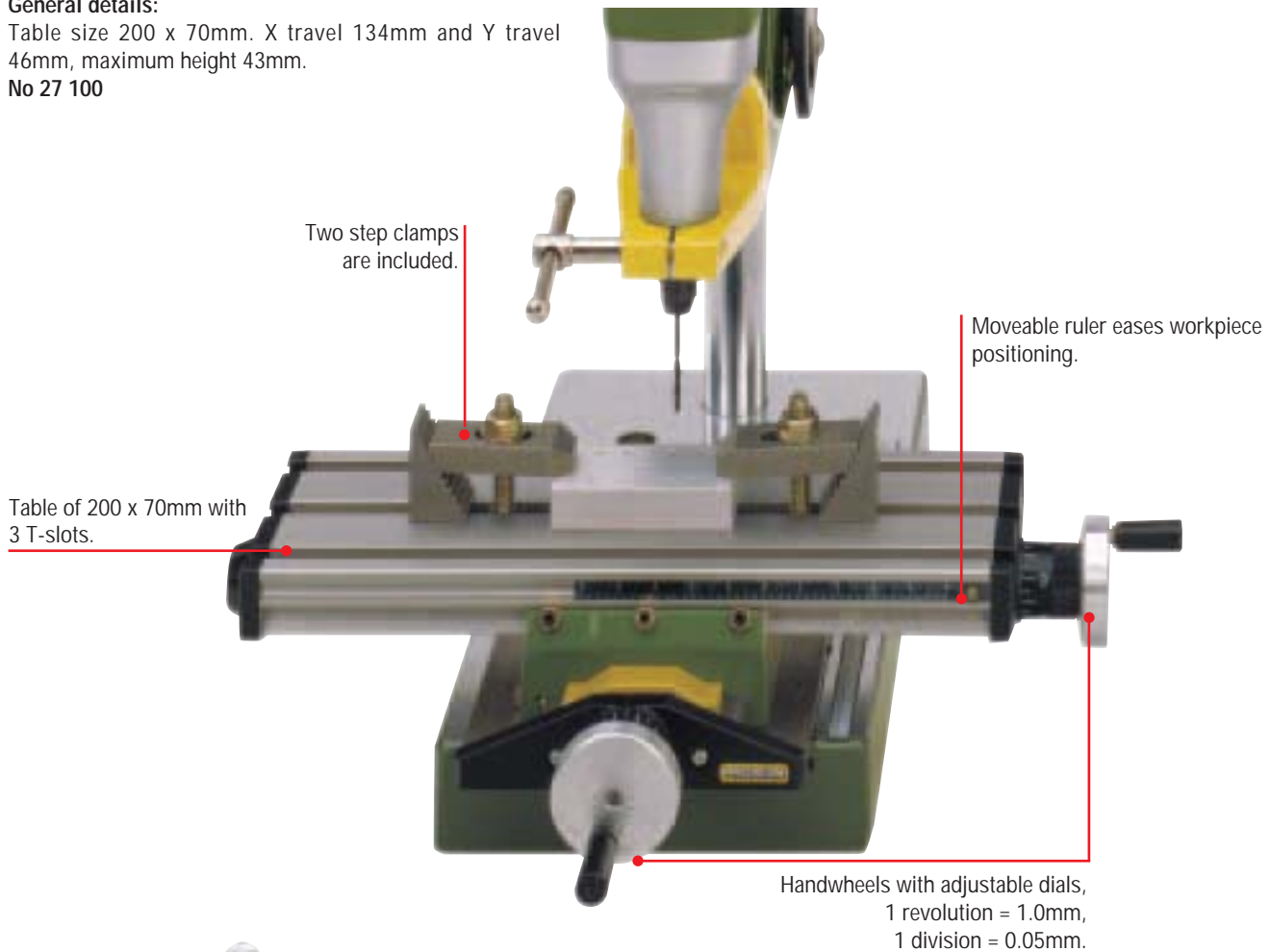

Two step clamps are included.

Moveable ruler eases workpiece positioning.

Table of 200 x 70mm with 3 T-slots.

Handwheels with adjustable dials,  
1 revolution = 1.0mm,  
1 division = 0.05mm.

## **Precision vise FMZ With integral clamp.**

Easily clamps to workbenches and tables of up to 60mm. Alternatively, use 2 standard screws to secure to the work surface. Zinc die-casting with ball and socket: rotates in all directions (even downwards). 75mm jaws with protective covers (for delicate workpieces). Jaws also with vertical and horizontal V-slots for clamping round workpieces. Maximum clamping width 70mm and weight 1.6kg.

No 28 608

## **Precision vise FMS 75**

As detailed above, but without clamp. A strong suction cup facilitates instantaneous fixing to any smooth, flat surface.

No 28 602

