

INTELLIGENT HIGH SIDE MOSFET POWER SWITCH

Features

- Current Limit for Short Circuit Protection
- Over-Temperature Protection
- Active Output Negative Clamp
- Reverse Battery Protection
- Broken Ground Protection
- Short to VCC Protection
- Low Noise Charge Pump
- Sleep Mode Supply Current
- 4kV ESD Protection On All Pins
- Logic Ground Isolated From Power Ground

General Description:

The IR6226 is a 5 terminal monolithic HIGH SIDE SWITCH with built in short circuit, over-temperature, ESD, inductive load turn off capability and diagnostic feedback.

The on-chip protection circuit limits the average current during short circuit if the drain current exceeds 20A. The protection circuit latches off the high side switch if the junction temperature exceeds 170°C and latches on after the junction temperature falls by 10°C. The drain to source voltage is actively clamped at 55V, improving its performance during turn off with inductive loads.

The on-chip charge pump high side driver stage is floating and referenced to the source of the power MOSFET. Thus the logic to power ground isolation can be as high as 50V. This allows operation with larger offset as well as controlling the switch during load energy recirculation or regeneration.

A diagnostic pin is provided for status feedback of short circuit, over temperature and open load detection.

$V_{cc(op)}$	5v-50v
$R_{ds(on)}$	100mΩ
I_{lim}	20A
$T_{j(sd)}$	170°C
E_{av}	200mJ

Applications

- Solenoid Driver
- DC Motor Driver

Truth Table

Condition	In	Out	Dg
Normal	H	H	H
Normal	L	L	L
Output Open	H	H	H
Output Open	L	H	H
Shorted Output	H	Current-Limiting	L
Shorted Output	L	L	L
Over-Temperature	H	L	L
Over-Temperature	L	L	L

Block Diagram

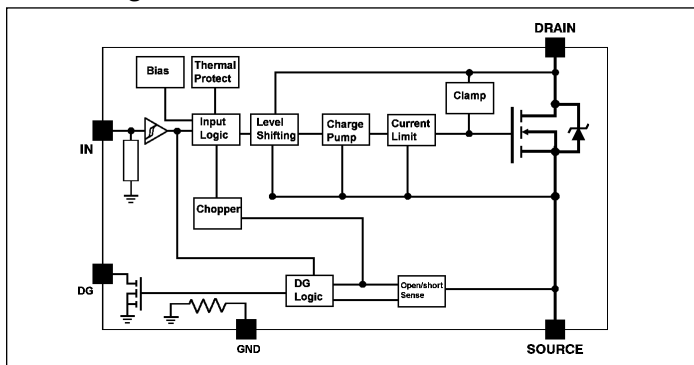

Available Packages

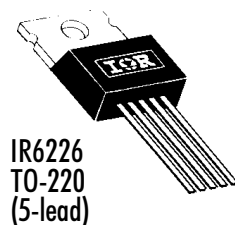

Absolute Maximum Ratings

Absolute Maximum Ratings indicate sustained limits beyond which damage to the device may occur. ($T_c = 25^\circ\text{C}$ unless otherwise specified.)

		Minimum	Maximum	Units	Test Conditions	
V_{cc}	Supply Voltage	Permanent	-0.3	50	V	Pin 3 to Pin 1 (1), for 10 seconds
		Reverse	-16	—		
V_{offset}	Logic to Power Ground Offset	$V_{cc} - 50$	$V_{cc} + 0.3$			
V_{in}	Input Voltage	-0.3	30			
I_{in}	Input Current	—	10	mA		
V_{out}	Output Voltage	$V_{cc} - 50$	$V_{cc} + 0.3$	V		
I_{out}	Output Current	Self-limited				
V_{dg}	Diagnostic Output Voltage	-0.3	30	V		
I_{dg}	Diagnostic Output Current	—	10	mA		
E_{av}	Repetitive Avalanche Energy	—	200	mJ	$I = 2\text{A}$ (2)	
ESD1	Electrostatic Discharge (Human Body Model)	—	4000	V	$C = 100\text{pF}$, $R = 1500\Omega$	
ESD2	Electrostatic Discharge (Machine Model)	—	1000	V	$C = 200\text{pF}$, $R = 0\Omega$	
PD	Power Dissipation	—	28	W	$T_{case} = 25^\circ\text{C}$	
T_{JOP}	Operating Junction Temperature Range	-40	Self-limited			
T_{Stg}	Storage Temperature Range	-40	175	$^\circ\text{C}$		
T_L	Lead Temperature (Soldering, 10 seconds)	—	300			

NOTES: (1) with 15k Ω resistors in input and diagnostic

(2) maximum frequency depends on heatsink (rectangular waveform)

Static Electrical Characteristics

($T_c = 25^\circ\text{C}$ unless otherwise specified.)

		Minimum	Typical	Maximum	Units	Test Conditions
V_{ccop}	Operating Voltage Range	5	—	50	V	
I_{ccoff}	Sleep Mode Supply Current	—	40	—	μA	$V_{cc} = 24\text{V}$, $V_{in} = 0\text{V}$
I_{ccon}	Supply Current (Average)	—	3	—	mA	$V_{in} = 5\text{V}$
I_{ccac}	Supply Current (AC RMS)	—	20	—	μA	$V_{in} = 5\text{V}$
V_{ih}	High Level Input Threshold Voltage	—	2	2.5	V	
V_{il}	Low Level Input Threshold Voltage	1	1.8	—		
I_{ion}	On-State Input Current	10	—	70	μA	$V_{in} = 3.5\text{V}$
I_{loff}	Off-State Input Current	1	—	30		$V_{in} = 0.4\text{V}$
I_{oh}	Output Leakage Current	—	20	—		$V_{out} = 6\text{V}$
I_{ol}	Output Leakage Current	0	—	10		$V_{out} = 0\text{V}$
V_{dgl}	Low Level Diagnostic Output Voltage	—	0.3	—	V	$I_{dg} = 1.6\text{mA}$
I_{dgh}	Diagnostic Output Leakage Current	0	—	10	μA	$V_{dg} = 5\text{V}$
$R_{DS(on)}$	On-State Resistance	—	80	100	$\text{m}\Omega$	$I_{out} = 1\text{A}$
		—	120	—		$V_{cc} = 5\text{V}$, $I_{out} = 1\text{A}$

Switching Electrical Characteristics

($V_{CC} = 14\text{V}$, Resistive Load (R_L) = 12 Ω , $T_c = 25^\circ\text{C}$.)

		Minimum	Typical	Maximum	Units	Test Conditions
t_{on}	Turn-On Delay Time to 90%	—	50	—	μs	
t_{off}	Turn-Off Delay Time to 10%	—	60	—		
dv/dt_{on}	Slew Rate On	—	3	—	V/ μs	
dv/dt_{off}	Slew Rate Off	—	5	—		

Protection Characteristics

	Minimum	Typical	Maximum	Units	Test Conditions	
I_{lim} Internal Current Limit	—	20	—	A		
V_{sc} Short Circuit Detection Voltage	—	3.5	—	V		
V_{slh} Open Load Detection Voltage	—	3.5	—			
V_{cl1} Output Negative Clamp	50	54	—			$I_{out} = 10mA$
V_{cl2} Output Negative Clamp	—	56	62			$I_{out} = 2A$

Thermal Characteristics

	Minimum	Typical	Maximum	Units	Test Conditions
T_{jcd} Thermal Shutdown Temperature	—	170	—	°C	
T_{hys} Thermal Hysteresis	—	5	—		
R_{thjc} Thermal Resistance, Junction to Case	—	3.5	—	°C/W	
R_{thja} Thermal Resistance, Junction to Ambient	—	50	—		

IR6226

Case Outline — TO-220 (IR6226)

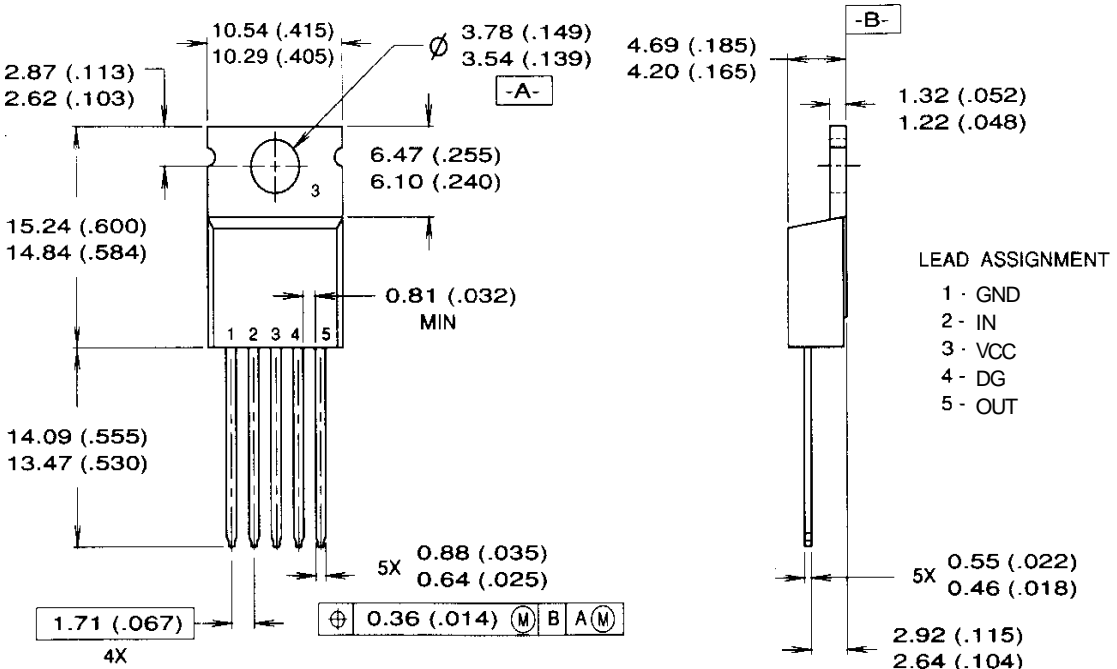

NOTES:

1. Dimensioning and tolerancing per ANSI Y14.5M, 1982
2. Controlling dimension: INCH
3. Dimensions shown are in millimeters (inches)
4. Heatsink and lead measurements do not include burrs.