

+5V Powered RS-232 Transmitters/Receivers with 0.1 Microfarad External Capacitors

The HIN200-HIN213 family of RS-232 transmitters/receivers interface circuits meet all EIA RS-232E and V.28 specifications, and are particularly suited for those applications where $\pm 12V$ is not available. They require a single +5V power supply (except HIN201 and HIN209) and feature onboard charge pump voltage converters which generate +10V and -10V supplies from the 5V supply. The HIN203 and HIN205 require no external capacitors and are ideally suited for applications where circuit board space is critical. The family of devices offers a wide variety of RS-232 transmitter/receiver combinations to accommodate various applications (see Selection Table).

The HIN200, HIN206, HIN211 and HIN213 feature a low power shutdown mode to conserve energy in battery powered applications. In addition, the HIN213 provides two active receivers in shutdown mode allowing for easy "wake-up" capability.

The drivers feature true TTL/CMOS input compatibility, slew rate-limited output, and 300 Ω power-off source impedance. The receivers can handle up to $\pm 30V$ input, and have a 3k Ω to 7k Ω input impedance. The receivers also feature hysteresis to greatly improve noise rejection.

Applications

- Any System Requiring RS-232 Communications Port
 - Computer - Portable, Mainframe, Laptop
 - Peripheral - Printers and Terminals
 - Instrumentation
 - Modems

Features

- Meets All RS-232E and V.28 Specifications
- HIN203 and HIN205 Require No External Capacitors
- Requires Only 0.1 μF or Greater External Capacitors
- 120kbit/s Data Rate
- Two Receivers Active in Shutdown Mode (HIN213)
- Requires Only Single +5V Power Supply
 - (+5V and +12V - HIN201 and HIN209)
- Onboard Voltage Doubler/Inverter
- Low Power Consumption (Typ) 5mA
- Low Power Shutdown Function (Typ) 1 μA
- Three-State TTL/CMOS Receiver Outputs
- Multiple Drivers
 - $\pm 10V$ Output Swing for +5V Input
 - 300 Ω Power-Off Source Impedance
 - Output Current Limiting
 - TTL/CMOS Compatible
 - 30V/ μs Maximum Slew Rate
- Multiple Receivers
 - $\pm 30V$ Input Voltage Range
 - 3k Ω to 7k Ω Input Impedance
 - 0.5V Hysteresis to Improve Noise Rejection

Selection Table

PART NUMBER	POWER SUPPLY VOLTAGE	NUMBER OF RS-232 DRIVERS	NUMBER OF RS-232 RECEIVERS	NUMBER OF 0.1 μF EXTERNAL CAPACITORS	LOW POWER SHUTDOWN/TTL THREE-STATE	NUMBER OF RECEIVERS ACTIVE IN SHUTDOWN
HIN200	+5V	5	0	4 Capacitors	Yes/No	0
HIN201	+5V and +9V to 13.2V	2	2	2 Capacitors	No/No	0
HIN202	+5V	2	2	4 Capacitors	No/No	0
HIN203	+5V	2	2	None	No/No	0
HIN204	+5V	4	0	4 Capacitors	No/No	0
HIN205	+5V	5	5	None	Yes/Yes	0
HIN206	+5V	4	3	4 Capacitors	Yes/Yes	0
HIN207	+5V	5	3	4 Capacitors	No/No	0
HIN208	5V	4	4	4 Capacitors	No/No	0
HIN209	+5V and +9V to 13.2V	3	5	2 Capacitors	No/Yes	0
HIN211	+5V	4	5	4 Capacitors	Yes/Yes	0
HIN213	+5V	4	5	4 Capacitors	Yes/Yes	2

HIN200 thru HIN213

Ordering Information

PART NO.	TEMP. RANGE (°C)	PACKAGE	PKG. NO.
HIN200CB	0 to 70	20 Ld SOIC	M20.3
HIN200IB	-40 to 85	20 Ld SOIC	M20.3
HIN201CB	0 to 70	16 Ld SOIC (W)	M16.3
HIN201IB	-40 to 85	16 Ld SOIC (W)	M16.3
HIN202CP	0 to 70	16 Ld PDIP	E16.3
HIN202CB	0 to 70	16 Ld SOIC (W)	M16.3
HIN202IP	-40 to 85	16 Ld PDIP	E16.3
HIN202CA	0 to 70	16 Ld SSOP	M16.209
HIN202IA	-40 to 85	16 Ld SSOP	M16.209
HIN202IB	-40 to 85	16 Ld SOIC (W)	M16.3
HIN202CBN	0 to 70	16 Ld SOIC (N)	M16.15
HIN202IBN	-40 to 85	16 Ld SOIC (N)	M16.15
HIN203CP	0 to 70	20 Ld PDIP	E20.3
HIN203CB	0 to 70	20 Ld SOIC (W)	M20.3
HIN204CB	0 to 70	16 Ld SOIC (W)	M16.3
HIN204IB	-40 to 85	16 Ld SOIC (W)	M16.3
HIN205CP	0 to 70	24 Ld PDIP (W)	E24.3
HIN206CP	0 to 70	24 Ld PDIP (N)	E24.3
HIN206CB	0 to 70	24 Ld SOIC	M24.3
HIN206CA	0 to 70	24 Ld SSOP	M24.209
HIN206IP	-40 to 85	24 Ld PDIP (N)	E24.3
HIN206IB	-40 to 85	24 Ld SOIC	M24.3
HIN206IA	-40 to 85	24 Ld SSOP	M24.209
HIN207CP	0 to 70	24 Ld PDIP (N)	E24.3

PART NO.	TEMP. RANGE (°C)	PACKAGE	PKG. NO.
HIN207CB	0 to 70	24 Ld SOIC	M24.3
HIN207CA	0 to 70	24 Ld SSOP	M24.209
HIN207IP	-40 to 85	24 Ld PDIP (N)	E24.3
HIN207IB	-40 to 85	24 Ld SOIC	M24.3
HIN207IA	-40 to 85	24 Ld SSOP	M24.209
HIN208CP	0 to 70	24 Ld PDIP (N)	E24.3
HIN208CB	0 to 70	24 Ld SOIC	M24.3
HIN208CA	0 to 70	24 Ld SSOP	M24.209
HIN208IP	-40 to 85	24 Ld PDIP (N)	E24.3
HIN208IB	-40 to 85	24 Ld SOIC	M24.3
HIN208IA	-40 to 85	24 Ld SSOP	M24.209
HIN209CP	0 to 70	24 Ld PDIP (N)	E24.3
HIN209CB	0 to 70	24 Ld SOIC	M24.3
HIN209IP	-40 to 85	24 Ld PDIP (N)	E24.3
HIN209IB	-40 to 85	24 Ld SOIC	M24.3
HIN211CB	0 to 70	28 Ld SOIC	M28.3
HIN211CA	0 to 70	28 Ld SSOP	M28.209
HIN211IB	-40 to 85	28 Ld SOIC	M28.3
HIN211IA	-40 to 85	28 Ld SSOP	M28.209
HIN213CB	0 to 70	28 Ld SOIC	M28.3
HIN213CA	0 to 70	28 Ld SSOP	M28.209
HIN213IB	-40 to 85	28 Ld SOIC	M28.3
HIN213IA	-40 to 85	28 Ld SSOP	M28.209

Pin Descriptions

PIN	FUNCTION
V _{CC}	Power Supply Input 5V ±10%, 5V ±5% (HIN200, HIN207, HIN203, and HIN205).
V+	Internally generated positive supply (+10V nominal), HIN201 and HIN209 requires +9V to +13.2V.
V-	Internally generated negative supply (-10V nominal).
GND	Ground lead. Connect to 0V.
C1+	External capacitor (+ terminal) is connected to this lead.
C1-	External capacitor (- terminal) is connected to this lead.
C2+	External capacitor (+ terminal) is connected to this lead.
C2-	External capacitor (- terminal) is connected to this lead.
T _{IN}	Transmitter Inputs. These leads accept TTL/CMOS levels. An internal 400kΩ pull-up resistor to V _{CC} is connected to each lead.
T _{OUT}	Transmitter Outputs. These are RS-232 levels (nominally ±10V).
R _{IN}	Receiver Inputs. These inputs accept RS-232 input levels. An internal 5kΩ pull-down resistor to GND is connected to each input.
R _{OUT}	Receiver Outputs. These are TTL/CMOS levels.
EN̄, EN	Enable input. This is an active low input which enables the receiver outputs. With EN̄ = 5V, (HIN213 EN = 0V), the outputs are placed in a high impedance state.
SD, SD̄	Shutdown Input. With SD = 5V (HIN213 SD̄ = 0V), the charge pump is disabled, the receiver outputs are in a high impedance state (except R4 and R5 of HIN213) and the transmitters are shut off.
NC	No Connect. No connections are made to these leads.

Pinouts

HIN200 (SOIC)
TOP VIEW

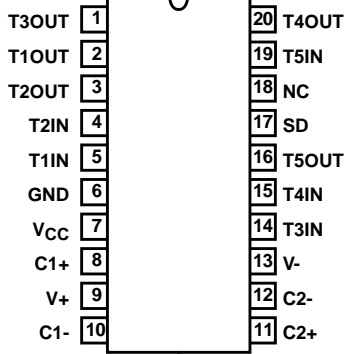

HIN201 (SOIC)
TOP VIEW

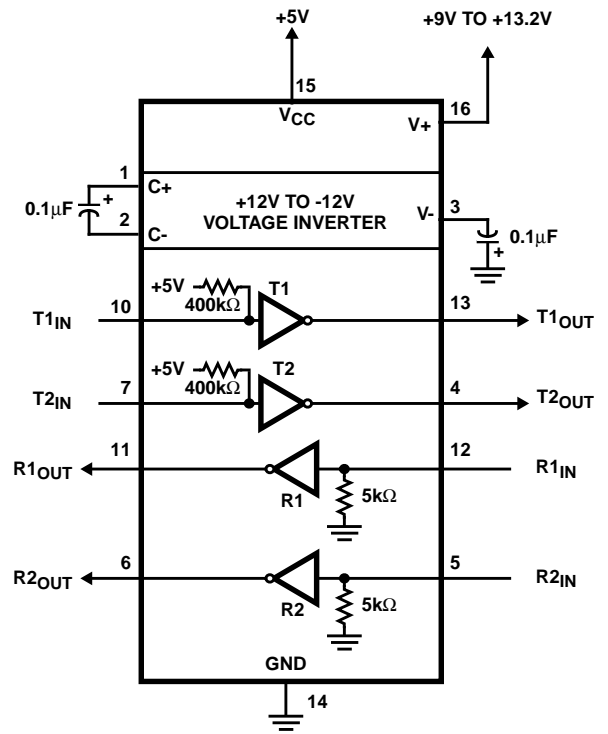
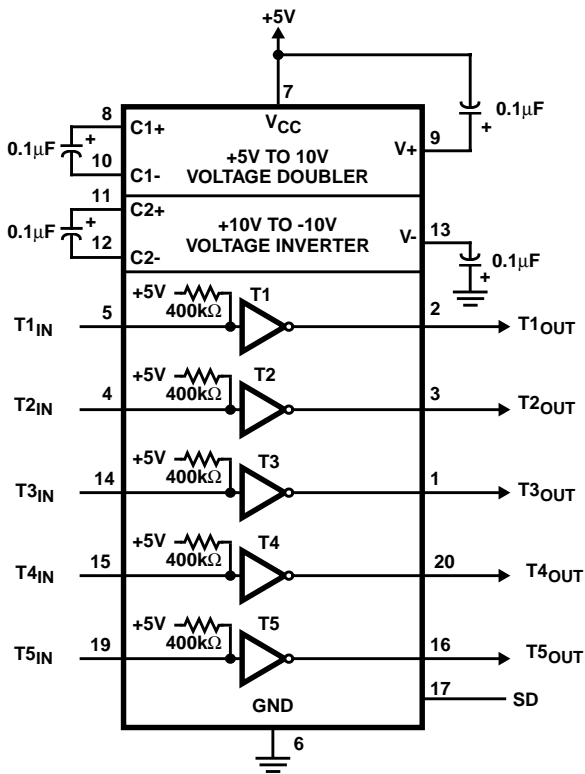
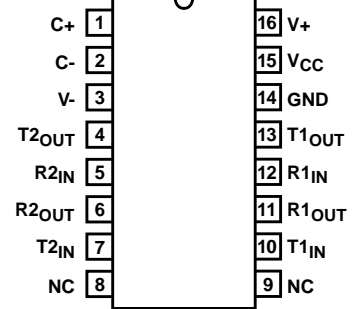

HIN200 thru HIN213

Pinouts (Continued)

HIN202 (PDIP, SOIC, SSOP)
TOP VIEW

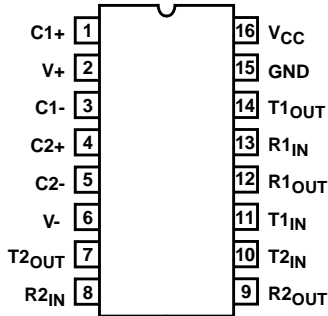

HIN203 (PDIP, SOIC)
TOP VIEW

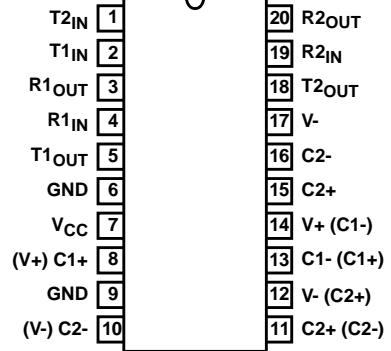

NOTE: Pin numbers in parentheses are for SOIC Package.

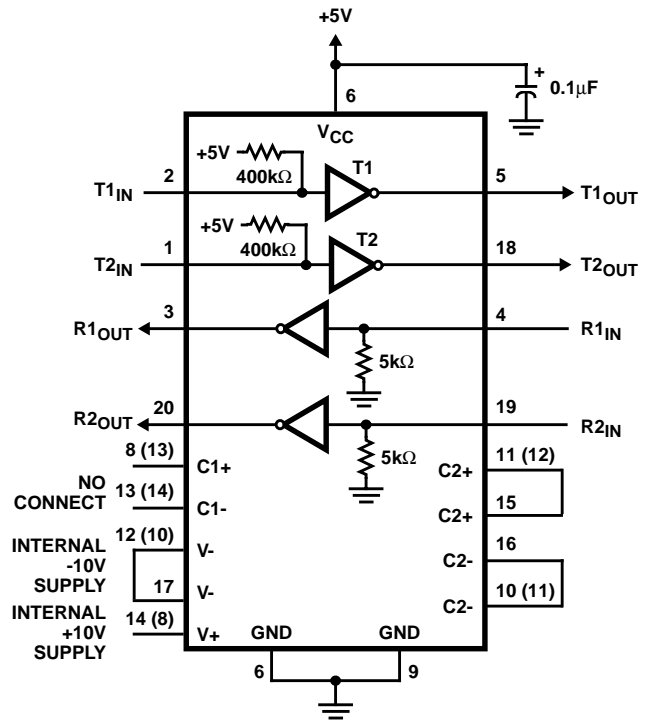
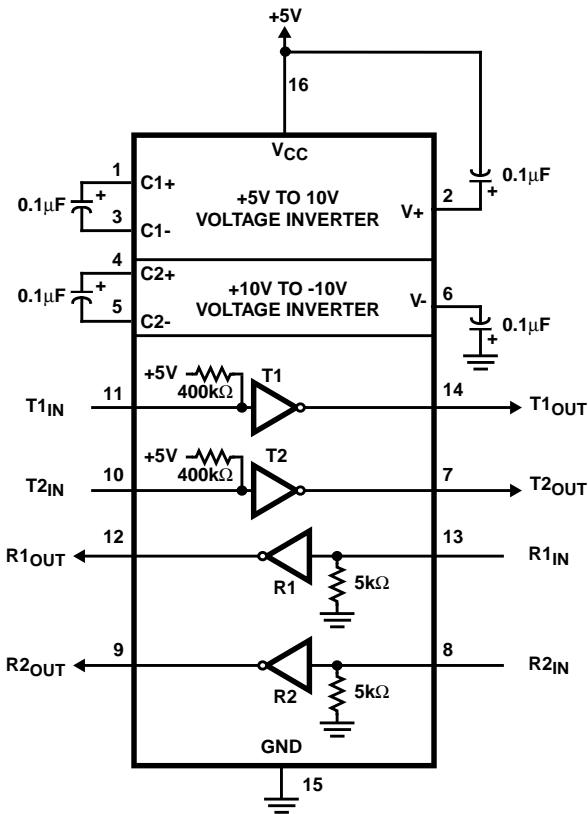

Pinouts (Continued)

HIN204 (SOIC)
TOP VIEW

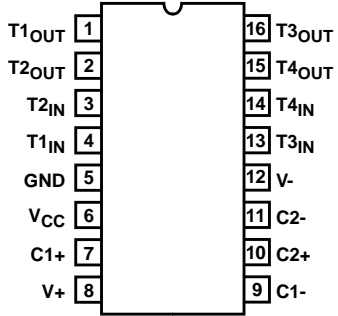

HIN205 (PDIP)
TOP VIEW

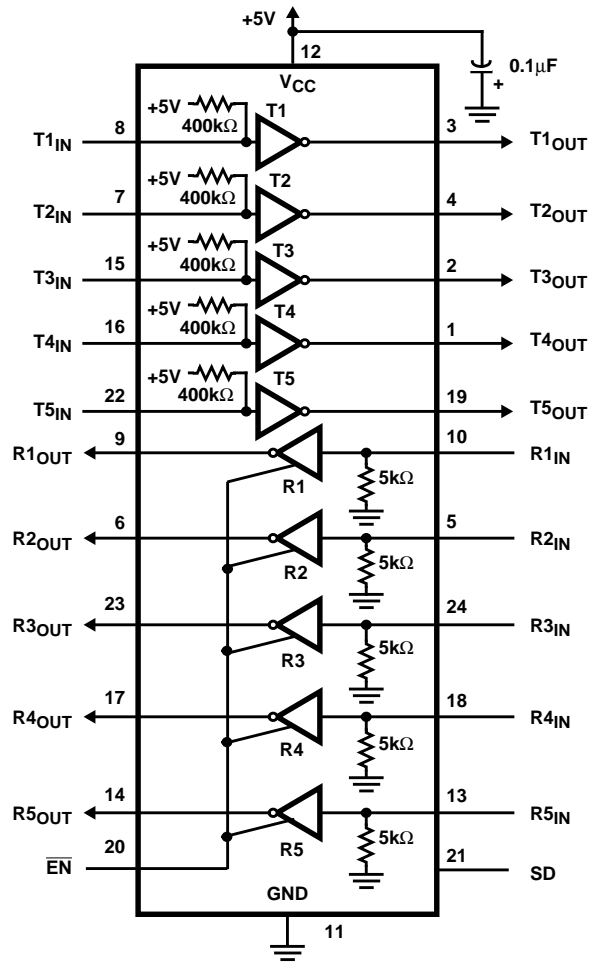
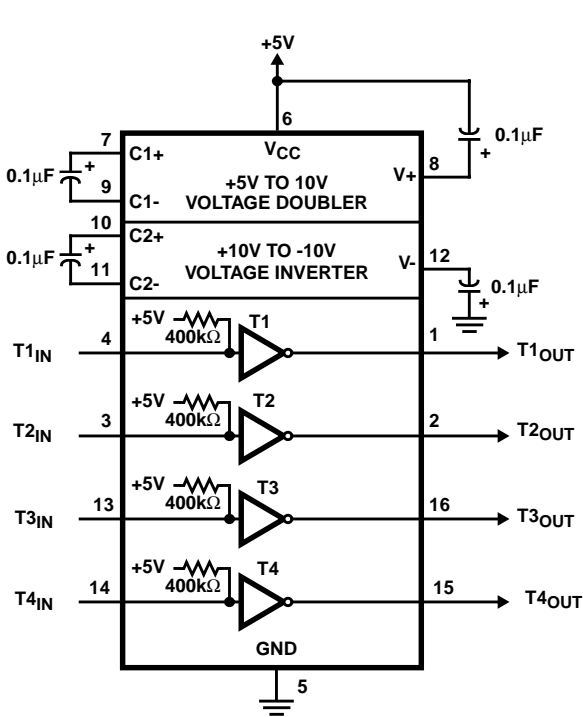
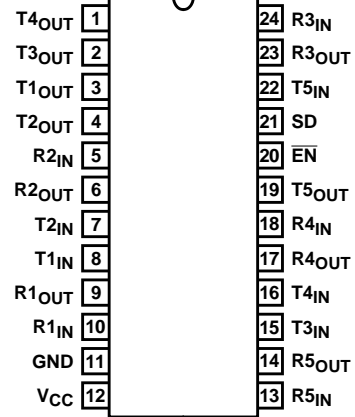

Pinouts (Continued)

HIN206 (PDIP, SOIC, SSOP)
TOP VIEW

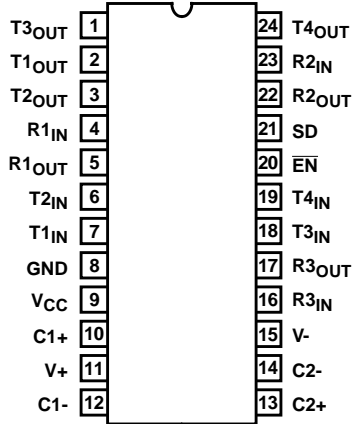

HIN207 (PDIP, SOIC, SSOP)
TOP VIEW

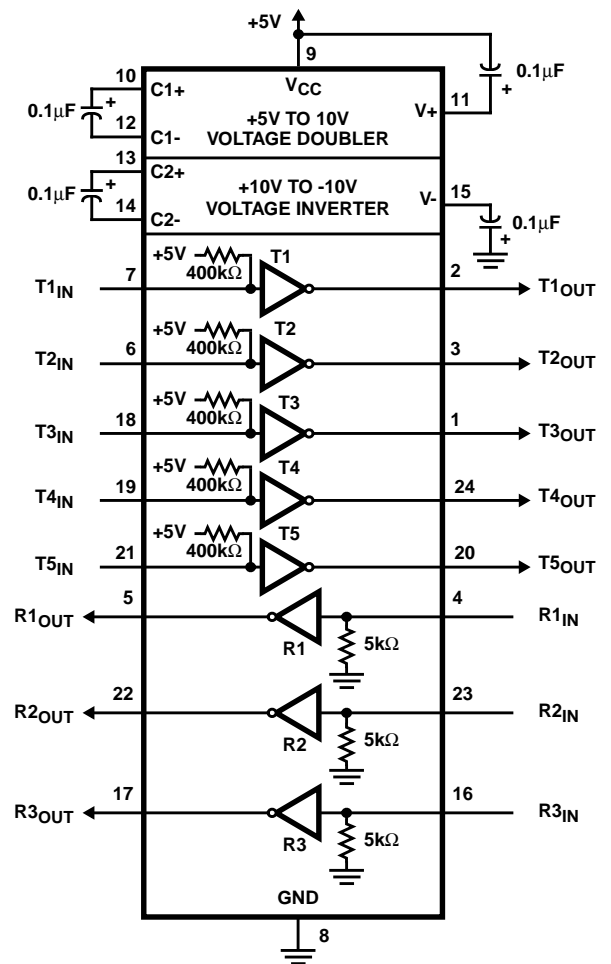
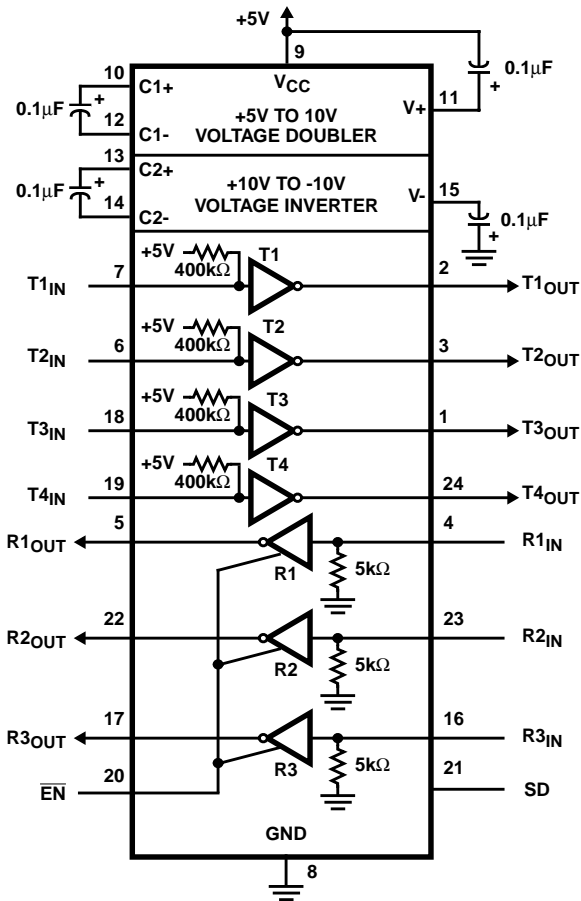
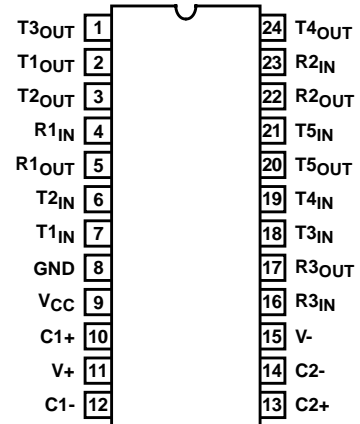

Pinouts (Continued)

HIN208 (PDIP, SOIC, SSOP)
TOP VIEW

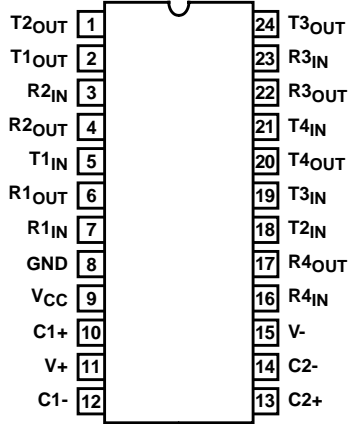

HIN209 (PDIP, SOIC, SSOP)
TOP VIEW

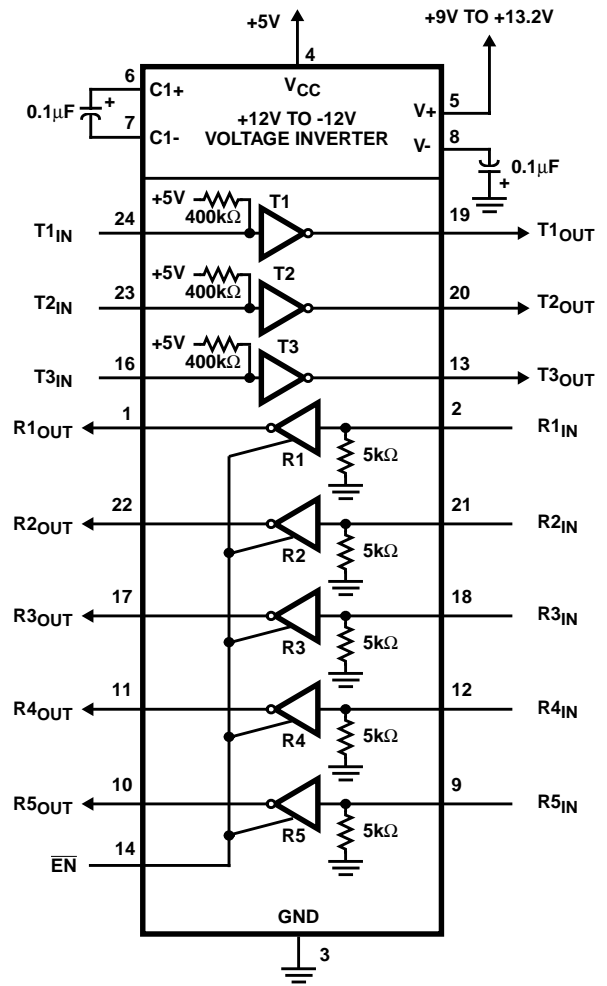
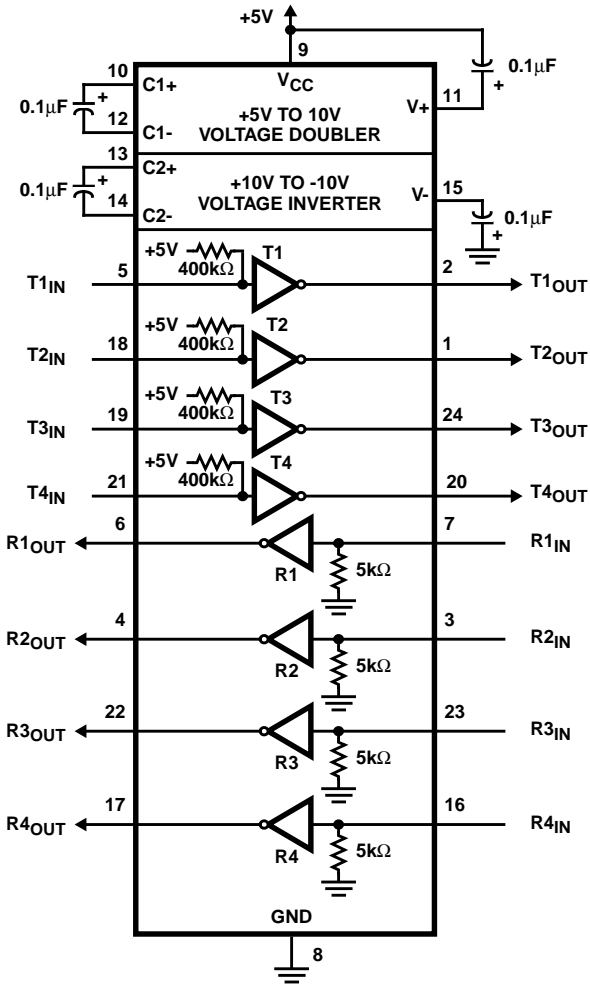
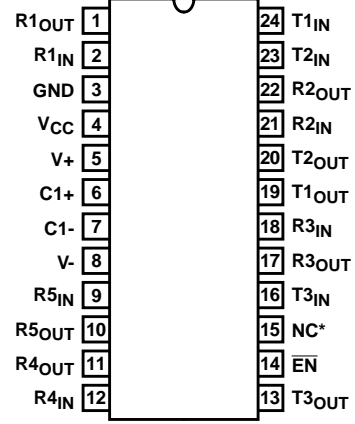

Pinouts (Continued)

HIN211 (SOIC, SSOP)
TOP VIEW

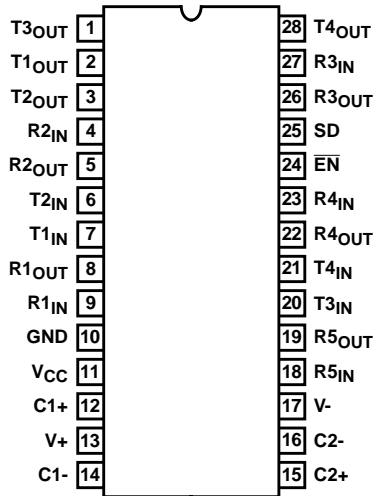

HIN213 (SOIC, SSOP)
TOP VIEW

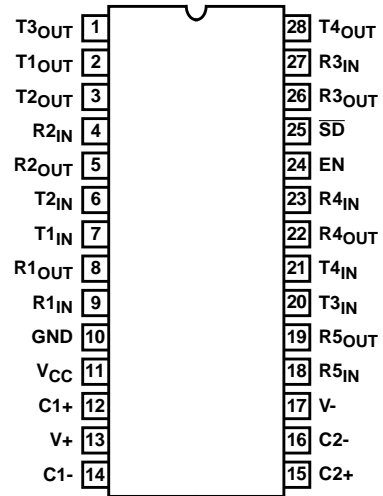

NOTE: R4 AND R5 ACTIVE IN SHUTDOWN

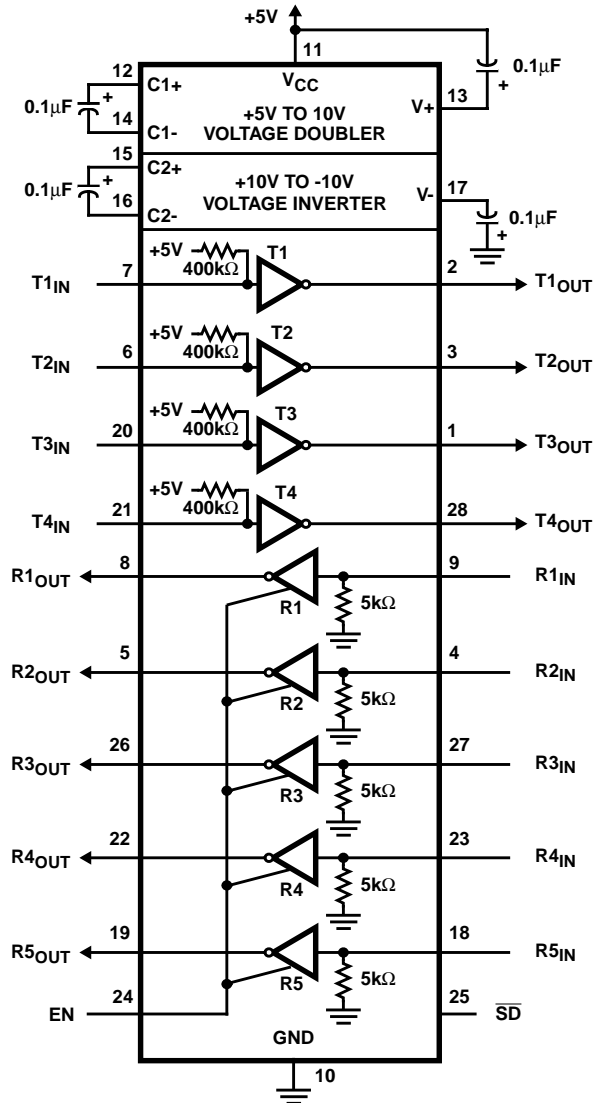
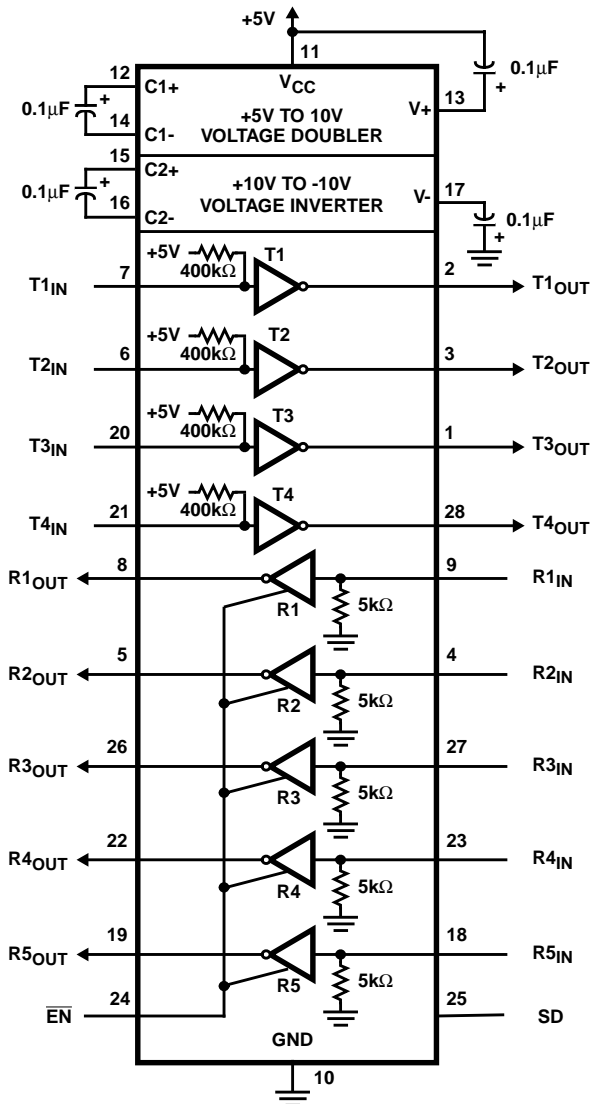

HIN200 thru HIN213

Absolute Maximum Ratings

V _{CC} to Ground	(GND -0.3V) < V _{CC} < 6V
V+ to Ground	(V _{CC} -0.3V) < V+ < 12V
V- to Ground	-12V < V- < (GND +0.3V)
Input Voltages	
T _{IN}	(V- -0.3V) < V _{IN} < (V+ +0.3V)
R _{IN}	±30V
Output Voltages	
T _{OUT}	(V- -0.3V) < V _{TXOUT} < (V+ +0.3V)
R _{OUT}	(GND -0.3V) < V _{RXOUT} < (V+ +0.3V)
Short Circuit Duration	
T _{OUT}	Continuous
R _{OUT}	Continuous
ESD Classification	Class 1

Thermal Information

Thermal Resistance (Typical, Note 1)	θ _{JA} (°C/W)
16 Ld SOIC (N) Package	115
16 Ld SOIC (W) Package	100
16 Ld SSOP Package	155
16 Ld PDIP Package	90
20 Ld SOIC Package	100
24 Ld SOIC Package	75
24 Ld SSOP Package	135
24 Ld PDIP (N) Package	75
24 Ld PDIP (W) Package	60
28 Ld SOIC Package	70
28 Ld SSOP Package	100
Maximum Junction Temperature (Plastic Package)	150°C
Maximum Storage Temperature	-65°C to 150°C
Maximum Lead Temperature (Soldering 10s)	300°C
(SOIC and SSOP - Lead Tips Only)	

Operating Conditions

Temperature Range	
HIN-XXXCX	0°C to 70°C
HIN-XXXIX	-40°C to 85°C

CAUTION: Stresses above those listed in "Absolute Maximum Ratings" may cause permanent damage to the device. This is a stress only rating and operation of the device at these or any other conditions above those indicated in the operational sections of this specification is not implied.

NOTE:

1. θ_{JA} is measured with the component mounted on an evaluation PC board in free air.

Electrical Specifications Test Conditions: V_{CC} = +5V ±10%, (V_{CC} = +5V ±5% HIN200, HIN203, HIN205, HIN207); V+ = 9V to 13.2V, HIN201 and HIN209), C1-C4 = 0.1µF; T_A = Operating Temperature Range

PARAMETER	TEST CONDITIONS		MIN	TYP	MAX	UNITS
Output Voltage Swing, T _{OUT}	Transmitter Outputs, 3kΩ to Ground		±5	±9	±10	V
Power Supply Current, I _{CC}	No Load, T _A = 25°C	HIN202, HIN203	-	8	15	mA
		HIN200, HIN204-208, HIN211-213	-	11	20	mA
		HIN201, HIN209	-	0.4	1	mA
V+ Power Supply Current, I _{CC}	No Load, T _A = 25°C	HIN201	-	5.0	10	mA
		HIN209	-	7.0	15	mA
Shutdown Supply Current, I _{CC} (SD)	T _A = 25°C	HIN200, HIN205, HIN206, HIN211	-	1	10	µA
		HIN213	-	15	50	µA
Input Logic Low, T _{IN} , \overline{EN} , V _{IL}	T _{IN} , \overline{EN} , SD, EN, \overline{SD}		-	-	0.8	V
Input Logic High, V _{IH}	T _{IN}		2.0	-	-	V
	\overline{EN} , SD, EN, \overline{SD}		2.4	-	-	V
Logic Pullup Current, I _P	T _{IN} = 0V		-	15	200	µA
RS-232 Input Voltage Range, V _{IN}			-30	-	+30	V
Receiver Input Impedance, R _{IN}	T _A = 25°C, V _{IN} = ±3V		3.0	5.0	7.0	kΩ
Receiver Input Low Threshold, V _{IN} (H-L)	V _{CC} = 5V, T _A = 25°C	Active Mode	0.8	1.2	-	V
		Shutdown Mode HIN213 R4 and R5	0.6	1.5	-	V
Receiver Input High Threshold, V _{IN} (L-H)	V _{CC} = 5V, T _A = 25°C	Active Mode	-	1.7	2.4	V
		Shutdown Mode HIN213 R4 and R5	-	1.5	2.4	V
Receiver Input Hysteresis, V _{HYST}	V _{CC} = 5V No Hysteresis in Shutdown Mode		0.2	0.5	1.0	V

HIN200 thru HIN213

Electrical Specifications Test Conditions: $V_{CC} = +5V \pm 10\%$, ($V_{CC} = +5V \pm 5\%$ HIN200, HIN203, HIN205, HIN207); $V+ = 9V$ to $13.2V$, HIN201 and HIN209), $C1-C4 = 0.1\mu F$; $T_A =$ Operating Temperature Range **(Continued)**

PARAMETER	TEST CONDITIONS	MIN	TYP	MAX	UNITS	
TTL/CMOS Receiver Output Voltage Low, V_{OL}	$I_{OUT} = 1.6mA$ (HIN201-HIN203, $I_{OUT} = 3.2mA$)	-	0.1	0.4	V	
TTL/CMOS Receiver Output Voltage High, V_{OH}	$I_{OUT} = -1mA$	3.5	4.6	-	V	
Output Enable Time, t_{EN}	HIN205, HIN206, HIN209, HIN211, HIN213	-	400	-	ns	
Output Disable Time, t_{DIS}	HIN205, HIN206, HIN209, HIN211, HIN213	-	200	-	ns	
Transmit, Receive Propagation Delay, t_{PD}	HIN213 $\overline{SD} = 0V$, R4, R5	-	0.5	40	μs	
	HIN213 $\overline{SD} = V_{CC}$, R1 - R5	-	0.5	10	μs	
	HIN200 - HIN211	-	0.5	10	μs	
Transmit Transition Region Slew Rate, SR_T	$R_L = 3k\Omega$, $C_L = 2500pF$ Measured from $+3V$ to $-3V$ or $-3V$ to $+3V$ (Note 2)	HIN200, HIN204 to HIN211, HIN213	3	-	30	$V/\mu s$
		HIN201, HIN202, HIN203	3	-	30	$V/\mu s$
Output Resistance, R_{OUT}	$V_{CC} = V+ = V- = 0V$, $V_{OUT} = \pm 2V$	300	-	-	Ω	
RS-232 Output Short Circuit Current, I_{SC}	T_{OUT} Shorted to GND	-	± 10	-	mA	
TTL/CMOS Receiver Output Leakage	$\overline{EN} = V_{CC}$, $EN = 0$, $0V < R_{OUT} < V_{CC}$	-	0.05	± 10	μA	

NOTE:

- Guaranteed by design.

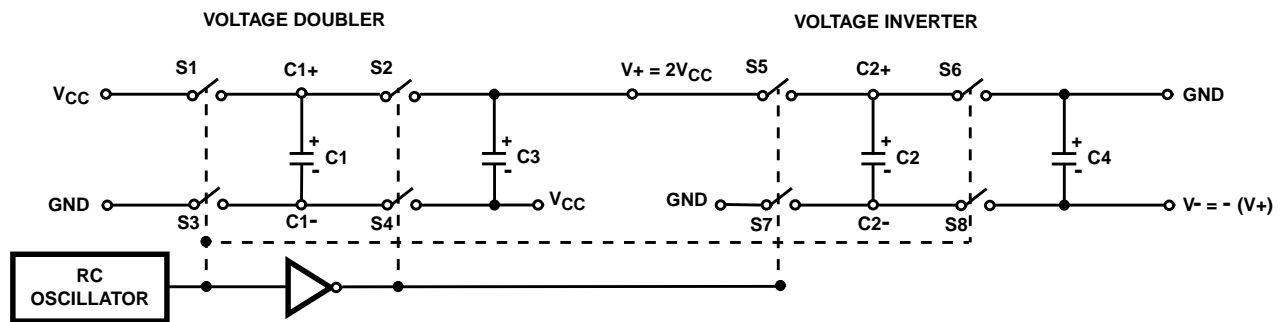

FIGURE 1. CHARGE PUMP

Detailed Description

The HIN200 thru HIN213 family of RS-232 transmitters/receivers are powered by a single +5V power supply (except HIN201 and HIN209), feature low power consumption, and meet all EIA RS232C and V.28 specifications. The circuit is divided into three sections: the charge pump, transmitter, and receiver.

Charge Pump

An equivalent circuit of the charge pump is illustrated in Figure 1. The charge pump contains two sections: the voltage doubler and the voltage inverter. Each section is driven by a two phase, internally generated clock to generate +10V and -10V. The nominal clock frequency is 125kHz. During phase one of the clock, capacitor C1 is charged to V_{CC} . During phase two, the voltage on C1 is added to V_{CC} , producing a signal across C3 equal to twice V_{CC} . During phase two, C2 is also charged to $2V_{CC}$, and then during phase one, it is inverted with respect to ground to produce a signal across C4 equal to $-2V_{CC}$. The charge pump accepts input voltages up to 5.5V. The output impedance of the voltage doubler section (V+) is approximately 200Ω, and the output impedance of the voltage inverter section (V-) is approximately 450Ω. A typical application uses 0.1μF capacitors for C1-C4, however, the value is not critical. Increasing the values of C1 and C2 will lower the output impedance of the voltage doubler and inverter, increasing the values of the reservoir capacitors, C3 and C4, lowers the ripple on the V+ and V- supplies.

During shutdown mode (HIN200, HIN206 and HIN211, $SD = V_{CC}$, HIN213, $SD = 0V$) the charge pump is turned off, V+ is pulled down to V_{CC} , V- is pulled up to GND, and the supply current is reduced to less than 10μA. The transmitter outputs are disabled and the receiver outputs (except for HIN213, R4 and R5) are placed in the high impedance state.

Transmitters

The transmitters are TTL/CMOS compatible inverters which translate the inputs to RS-232 outputs. The input logic threshold is about 26% of V_{CC} , or 1.3V for $V_{CC} = 5V$. A logic 1 at the input results in a voltage of between -5V and V- at the output, and a logic 0 results in a voltage between +5V and (V+ - 0.6V). Each transmitter input has an internal 400kΩ pullup resistor so any unused input can be left unconnected and its output remains in its low state. The output voltage swing meets the RS-232C specifications of ±5V minimum with the worst case conditions of: all transmitters driving 3kΩ minimum load impedance, $V_{CC} = 4.5V$, and maximum allowable operating temperature. The transmitters have an internally limited output slew rate which is less than 30V/μs. The outputs are short circuit protected and can be shorted to ground indefinitely. The powered down output impedance is a minimum of 300Ω with ±2V applied to the outputs and $V_{CC} = 0V$.

Receivers

The receiver inputs accept up to ±30V while presenting the required 3kΩ to 7kΩ input impedance even if the power is off ($V_{CC} = 0V$). The receivers have a typical input threshold of 1.3V which is within the ±3V limits, known as the transition region, of the RS-232 specifications. The receiver output is 0V to V_{CC} . The output will be low whenever the input is greater than 2.4V and high whenever the input is floating or driven between +0.8V and -30V. The receivers feature 0.5V hysteresis (except during shutdown) to improve noise rejection. The receiver Enable line (\overline{EN} , on HIN206, HIN209, and HIN211, EN on HIN213) when unasserted, disables the receiver outputs, placing them in the high impedance mode. The receiver outputs are also placed in the high impedance state when in shutdown mode (except HIN213 R4 and R5).

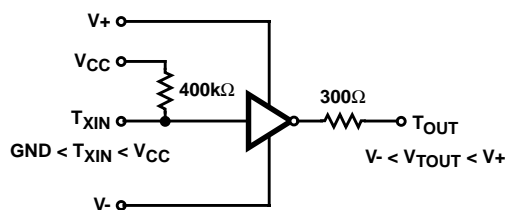

FIGURE 2. TRANSMITTER

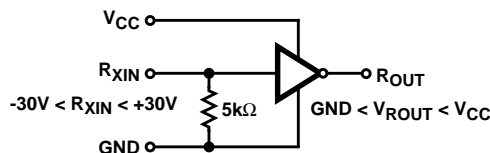
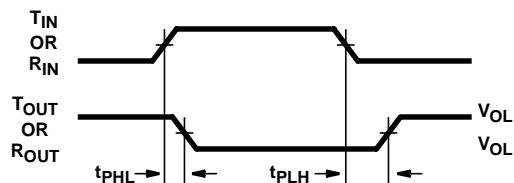

FIGURE 3. RECEIVER



$$\text{AVERAGE PROPAGATION DELAY} = \frac{t_{PHL} + t_{PLH}}{2}$$

FIGURE 4. PROPAGATION DELAY DEFINITION

HIN213 Operation in Shutdown

The HIN213 features two receivers, R4 and R5, which remain active in shutdown mode. During normal operation the receivers propagation delay is typically 0.5μs. This propagation delay may increase slightly during shutdown. When entering shut down mode, receivers R4 and R5 are not valid for 80μs after $SD = V_{IL}$. When exiting shutdown mode, all receiver outputs will be invalid until the charge pump circuitry reaches normal operating voltage. This is typically less than 2ms when using 0.1μF capacitors.

Typical Performance Curves

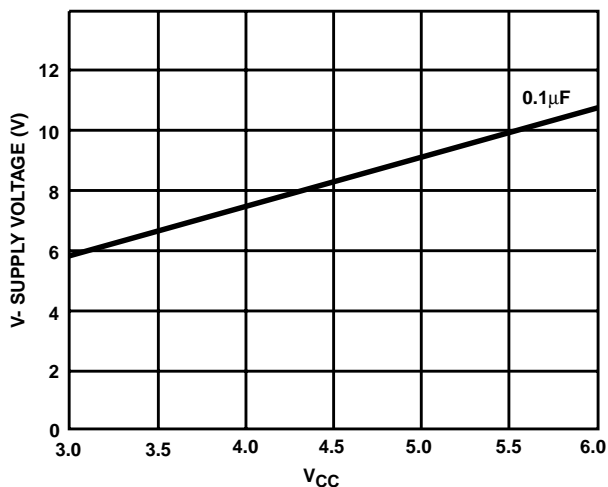

FIGURE 5. V- SUPPLY VOLTAGE vs VCC

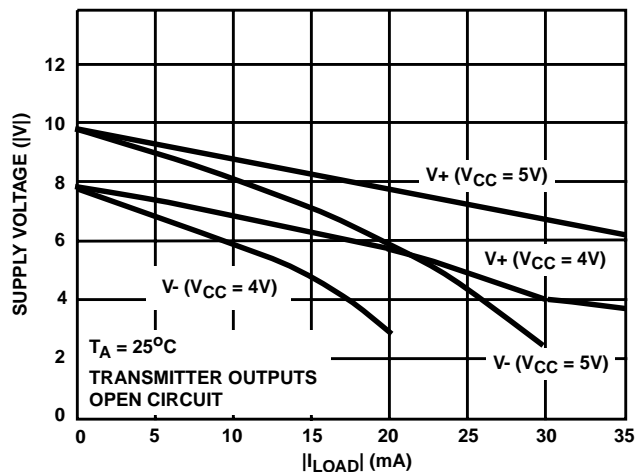

FIGURE 6. V+, V- OUTPUT VOLTAGE vs LOAD

Test Circuits (HIN202)

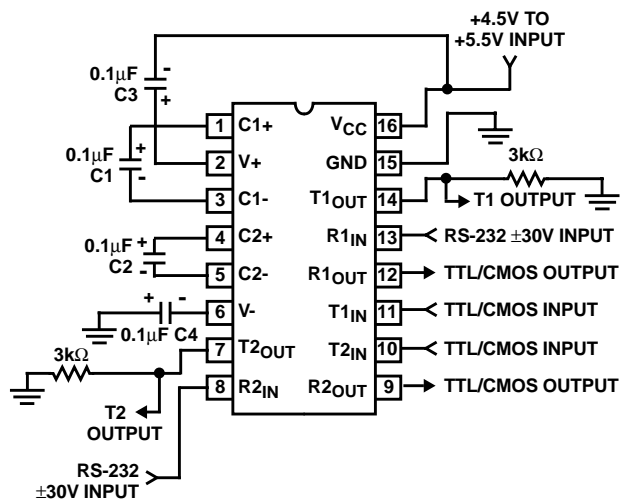

FIGURE 7. GENERAL TEST CIRCUIT

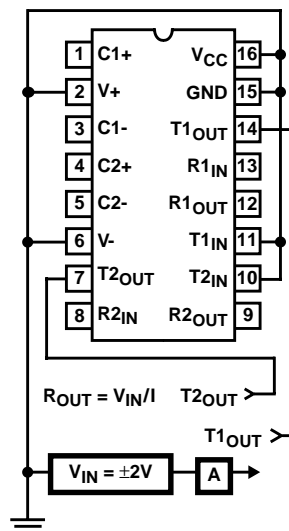

FIGURE 8. POWER-OFF SOURCE RESISTANCE CONFIGURATION

Application Information

The HINXXX may be used for all RS-232 data terminal and communication links. It is particularly useful in applications where $\pm 12V$ power supplies are not available for conventional RS-232 interface circuits. The applications presented represent typical interface configurations.

A simple duplex RS-232 port with CTS/RTS handshaking is illustrated in Figure 9. Fixed output signals such as DTR (data terminal ready) and DSRS (data signaling rate select) is generated by driving them through a $5k\Omega$ resistor connected to V+.

In applications requiring four RS-232 inputs and outputs (Figure 10), note that each circuit requires two charge pump capacitors (C1 and C2) but can share common reservoir capacitors (C3 and C4). The benefit of sharing common reservoir capacitors is the elimination of two capacitors and the reduction of the charge pump source impedance which effectively increases the output swing of the transmitters.

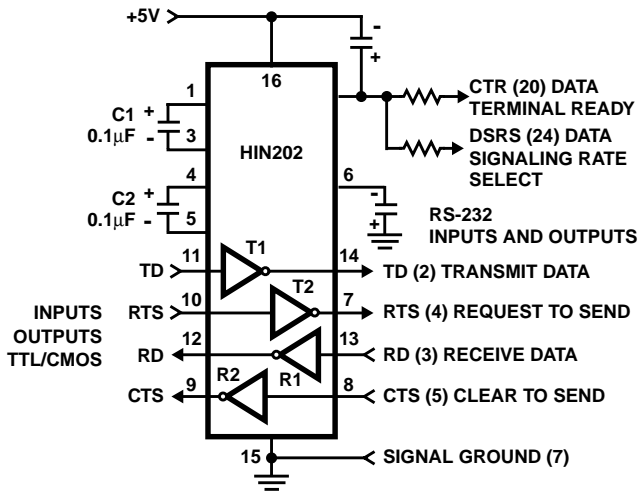

FIGURE 9. SIMPLE DUPLEX RS-232 PORT WITH CTS/RTS HANDSHAKING

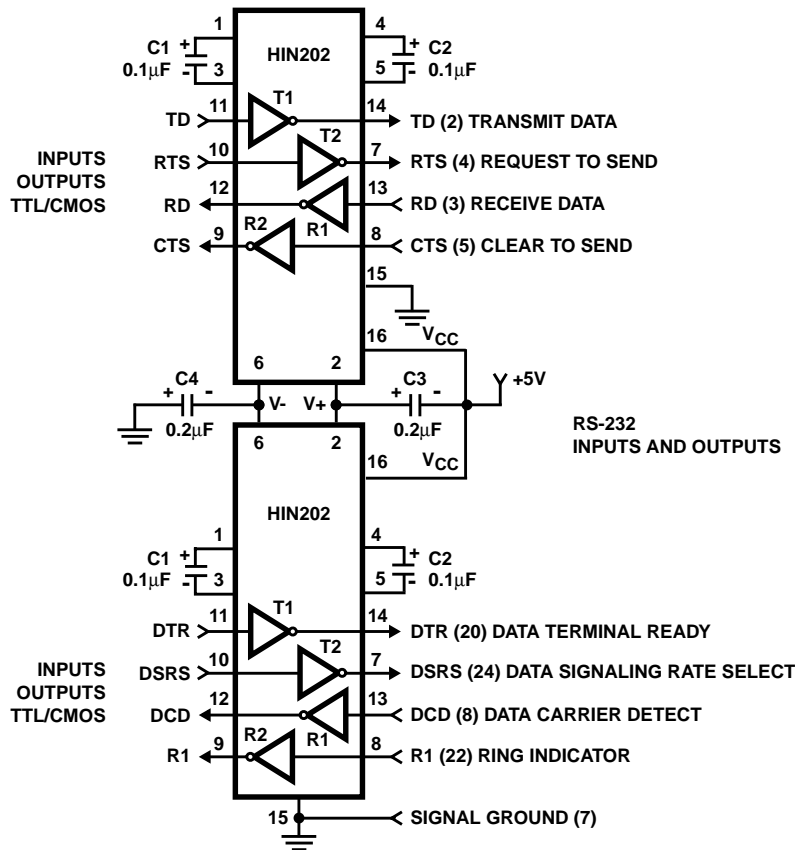

FIGURE 10. COMBINING TWO HIN202s FOR 4 PAIRS OF RS-232 INPUTS AND OUTPUTS

HIN200 thru HIN213

Die Characteristics

DIE DIMENSIONS:

160 mils x 140 mils

METALLIZATION:

Type: Al

Thickness: $10\text{k}\text{\AA} \pm 1\text{k}\text{\AA}$

SUBSTRATE POTENTIAL

V+

PASSIVATION:

Type: Nitride over Silox

Nitride Thickness: $8\text{k}\text{\AA}$

Silox Thickness: $7\text{k}\text{\AA}$

TRANSISTOR COUNT:

238

PROCESS:

CMOS Metal Gate

Metallization Mask Layout

HIN211

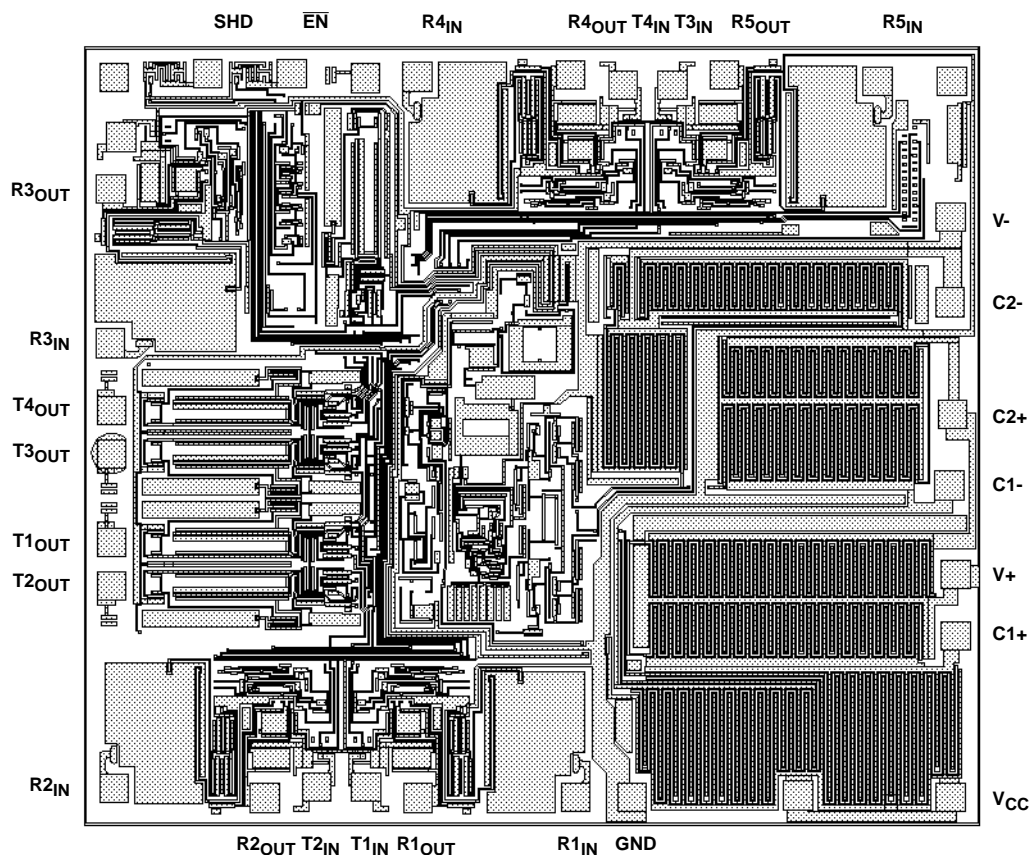

All Intersil semiconductor products are manufactured, assembled and tested under **ISO9000** quality systems certification.

Intersil semiconductor products are sold by description only. Intersil Corporation reserves the right to make changes in circuit design and/or specifications at any time without notice. Accordingly, the reader is cautioned to verify that data sheets are current before placing orders. Information furnished by Intersil is believed to be accurate and reliable. However, no responsibility is assumed by Intersil or its subsidiaries for its use; nor for any infringements of patents or other rights of third parties which may result from its use. No license is granted by implication or otherwise under any patent or patent rights of Intersil or its subsidiaries.

For information regarding Intersil Corporation and its products, see web site <http://www.intersil.com>

Sales Office Headquarters

NORTH AMERICA

Intersil Corporation
P. O. Box 883, Mail Stop 53-204
Melbourne, FL 32902
TEL: (407) 724-7000
FAX: (407) 724-7240

EUROPE

Intersil SA
Mercure Center
100, Rue de la Fusee
1130 Brussels, Belgium
TEL: (32) 2.724.2111
FAX: (32) 2.724.22.05

ASIA

Intersil (Taiwan) Ltd.
7F-6, No. 101 Fu Hsing North Road
Taipei, Taiwan
Republic of China
TEL: (886) 2 2716 9310
FAX: (886) 2 2715 3029