

MCP Indoor Call Point Range

MCP1 - Resistor & Clean Contact Model (Red Versions)

Product Benefits

- Unique 'Plug & Play' installation concept
- Total 'Flex-Ability' in the choice of operating element
- Anti-Tamper facility
- Enhanced aesthetics
- Fully approved to the latest standards
- Backward compatibility

Product Approvals



166b/39 & 166b/40



Pending



Product Overview

Installation efficiency, flexibility and full compliance with the latest standards are at the heart of the new MCP Indoor Call Point range.

Installation time and ultimately cost, are of paramount importance to any fire or security installer. The MCP range directly reflects this need by providing a unique 'plug and play' concept designed specifically to reduce installation time. All new MCP products utilise a special terminal block, where all initial installation cabling is terminated. This terminal block is then simply connected to the back of the MCP. Simple, but effective with no re-termination required and no time wasted.

Through new standards and legislation, both break glass and re-settable operating elements can now be used within a manual call point. To provide you with the greatest 'flex-ability', the new MCP range can be configured as either a break glass or re-settable unit by simply changing from one element to another. No other additional parts or alternative products need to be ordered.

All MCP Indoor Call Point products also help preserve the integrity of the overall system as illegal removal of the product lid will result in the call point operating and the system going in to alarm.

Full compliance with the latest standards is essential and the new MCP indoor call point range is fully approved to the latest EN54-11 standard.

The MCP1A product version is supplied with both a resistor and normally open clean contact electrical options. These options are easily utilised by simply connecting the terminal block to the required connection in the back of the MCP1 product. A variety of resistor versions are available, with both 470Ω and 680Ω offered as standard. However, other resistor types can be provided upon request. The MCP1B product version allows for connection to 'Sawwire' systems.

Electrical Specification

Connection Details: See Figure .1
 Max: 30VDC
 Cable Termination: 0.5-2.5mm²

Figure .1

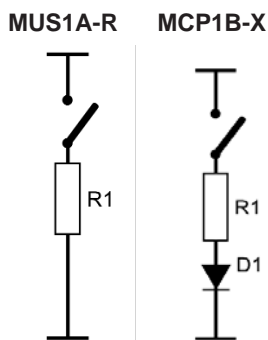

Environmental Specification

Humidity: 0-95% non-condensing
 Operating Temperature: -40°C to +55°C
 Storage Temperature: -40°C to +55°C
 Ingress Protection (IP) Rating: IP24D

Mechanical Specification

Material: PC/ABS
 Weight: 110g Flush/160g Surface
 Colour: Red, Ral 3001

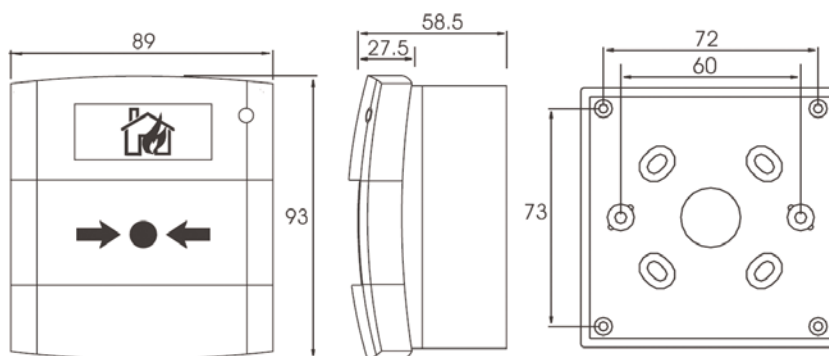

Ordering Information

Model	Electrical Configuration	Operating Element	Mounting	Markings
Stock				
MUS1A-R470FG-01	4700hm Resistor & N/O 24VDC	Glass	Flush	EN54-11
MUS1A-R470FF-01	4700hm Resistor & N/O 24VDC	Flexible	Flush	EN54-11
MUS1A-R680FG-01	6800hm Resistor & N/O 24VDC	Glass	Flush	EN54-11
MUS1A-R470SG-01	4700hm Resistor & N/O 24VDC	Glass	Surface	EN54-11
MUS1A-R470SF-01	4700hm Resistor & N/O 24VDC	Flexible	Surface	EN54-11
MUS1A-R680SG-01	6800hm Resistor & N/O 24VDC	Glass	Surface	EN54-11
MUS1B-R470SG01	4700hm Resistor & N/O 24VDC (Sawwire)	Glass	Surface	EN54-11
Non-Stock				
MCP1A-R680FF-01	6800hm Resistor & N/O 24VDC	Flexible	Flush	EN54-11
MCP1B-R470FG-01	4700hm Resistor & N/O 24VDC (Sawwire)	Glass	Flush	EN54-11
MCP1B-R470FF-01	4700hm Resistor & N/O 24VDC (Sawwire)	Flexible	Flush	EN54-11
MCP1A-R680SF-01	6800hm Resistor & N/O 24VDC	Flexible	Surface	EN54-11
MCP1B-R470FG-01	4700hm Resistor & N/O 24VDC (Sawwire)	Glass	Surface	EN54-11
MCP1B-R470FF-01	4700hm Resistor & N/O 24VDC (Sawwire)	Flexible	Surface	EN54-11

N/O = Normally Open Contact

Accessories

Code	Description
SC070	Pack Of Ten Test Keys
KG1 x 5	Pack Of five Glass Elements
PS210	Flexible Operating Element
PS200	Plain Hinged Cover
SC071	Pack Of Ten Terminal Blocks