

MATERIAL NUMBER	ENGINEERING NUMBER	STUD SIZE "S" ±.010/.(0.25)	MATERIAL	PLATING
190850001	19085-0001	#6 = .146/(3.71)	BRASS	NONE
190850002	19085-0002	#8 = .173/(4.39)	BRASS	NONE
190850003	19085-0003	#10 = .198/(5.03)	BRASS	NONE
190850004	RZ-4129-06	#6 = .146/(3.71)	BRASS	TIN
190850005	RZ-4129-08	#8 = .173/(4.39)	BRASS	TIN
190850006	RZ-4129-10	#10 = .198/(5.03)	BRASS	TIN
190850007	RZ-S-4129-06	#6 = .146/(3.71)	STEEL	TIN
190850008	RZ-S-4129-08	#8 = .173/(4.39)	STEEL	TIN
190850009	RZ-S-4129-10	#10 = .198/(5.03)	STEEL	TIN

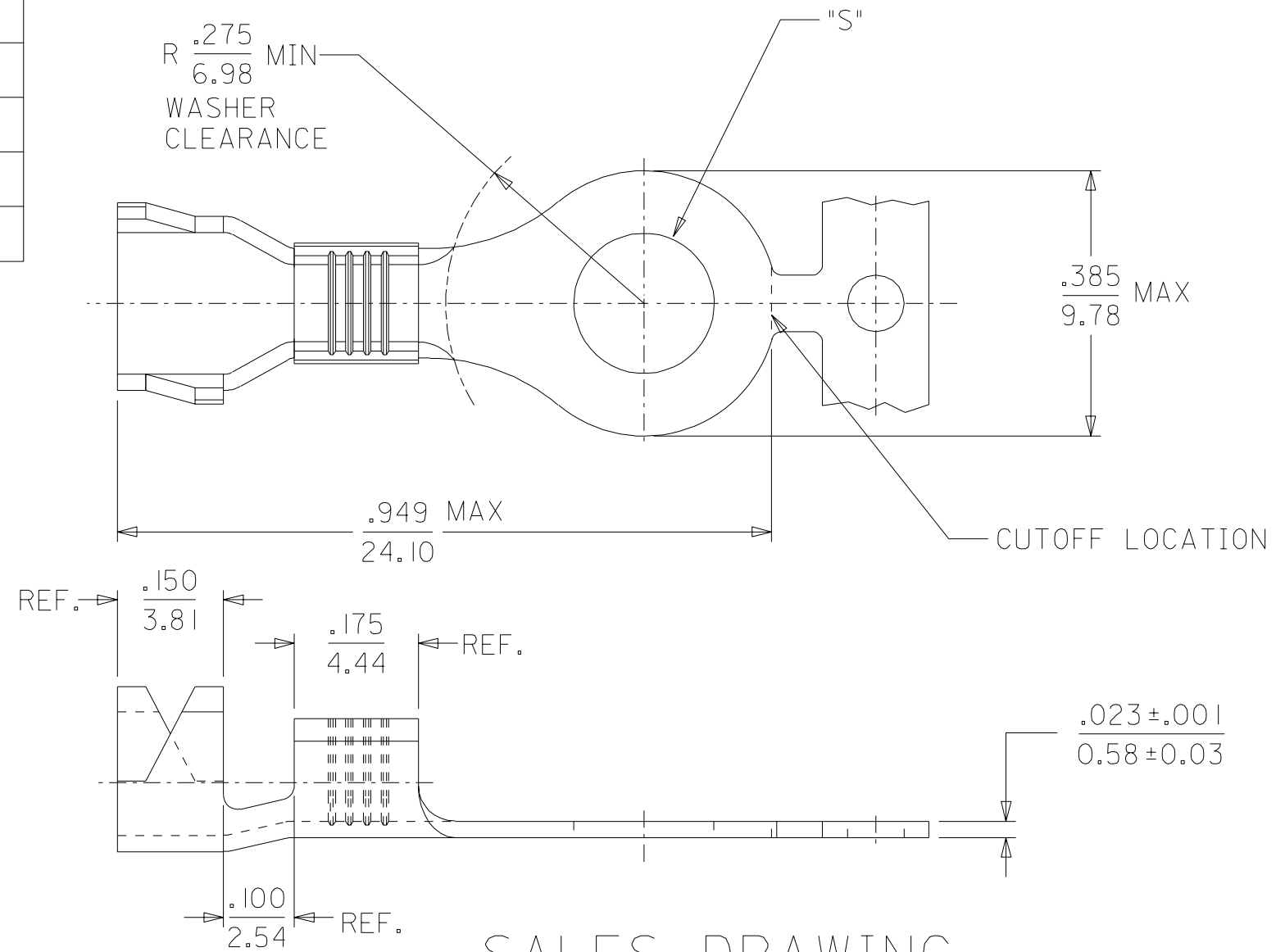

SALES DRAWING

- NOTES:
1. MATERIAL: SEE CHART.
  2. PLATING: SEE CHART.
  3. WIRE RANGE: 18-14 AWG/1.3-2.6 MM.<sup>2</sup>

WAS CD-4116 EC NO. ETC2002-0287 DRWN: BRE 02/04/10 CHK: HEB 02/04/10 APPR: RWD 02/04/10	QUALITY SYMBOLS	GENERAL TOLERANCES: (UNLESS SPECIFIED)		SCALE NO: NE	DESIGN UNITS <input type="checkbox"/> mm <input checked="" type="checkbox"/> INCH	THIRD ANGLE PROJECTION <input type="checkbox"/> mm <input checked="" type="checkbox"/> INCH <input type="checkbox"/> mm ONLY	SHT	REV
	MAJOR = 0	mm	INCH	DRAWN BY & DATE BRE 02/04/02		TITLE: VIBRAKRIMP STRIP RING TONGUE TERMINAL		
	CRITICAL = 0	4 PLACES ±0.	±.	CHECKED BY & DATE HEB 02/04/02		MOLEX INCORPORATED		
		3 PLACES ±0.	±.	APPROVED BY & DATE RWD 02/04/02		MATERIAL NO. SEE CHART	DRAWING NO. SD-19085-002	SHEET NO. 1 OF 1
	2 PLACES ±0.	±.	ANGULAR: ± 1/2 °		CAD FILENAME SD-19085-002 .DGN	THIS DRAWING CONTAINS INFORMATION THAT IS PROPRIETARY TO MOLEX INCORPORATED AND SHOULD NOT BE USED WITHOUT WRITTEN PERMISSION.		
	1 PLACE ±0.	±.	DRAFT WHERE APPLICABLE MUST REMAIN WITHIN DIMENSIONS		SIZE B			