

NO	DESCRIPTION	DATE
①	CHANGE THE DIRECTION OF FLAT	06.01.02

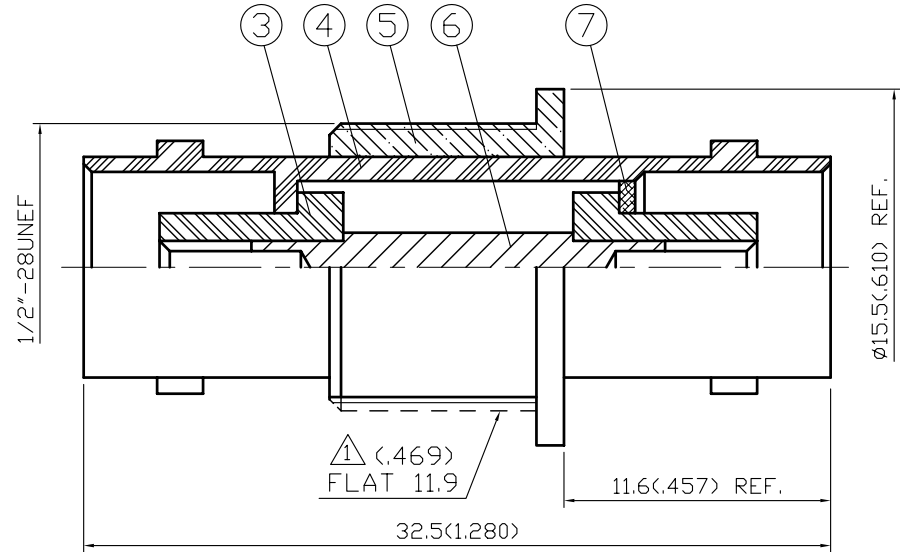
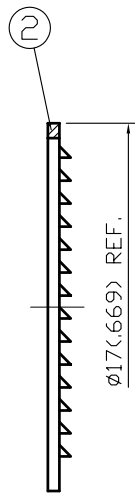
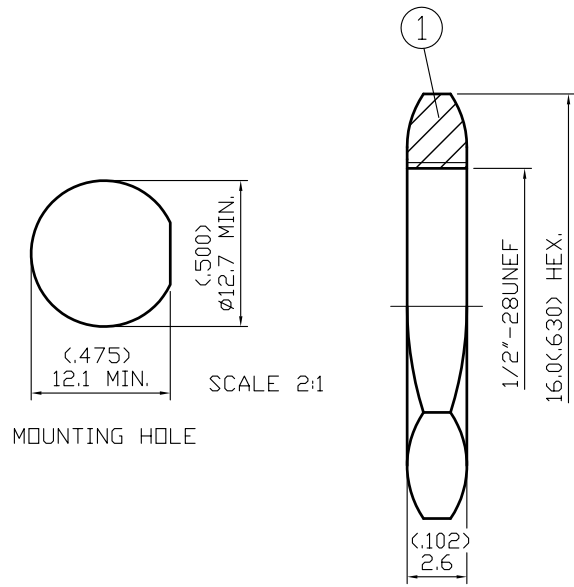

NOTES: UNLESS OTHERWISE SPECIFIED

- BODIES: BRASS PER JIS-C3604
- CENTER CONTACT: BRASS PER JIS-C3604
- INSULATION: TEFLON PER ASTM D1457 AND ASTM D1710
- CONNECTOR INTERFACE PER MIL-STD-348A
- PART TO BE CLEAN AND FREE OF BURRS

NO	DESCRIPTION	MATERIAL	Q'TY	FINISH
7	WASHER	BRASS	1	NICKEL 100 μ " MIN.
6	CENTER CONTACT	BRASS	1	GOLD
5	INSULATION	ABS	1	NONE
4	BODY	BRASS	1	NICKEL 100 μ " MIN.
3	INSULATION	POM	2	NONE
2	WASHER	IRON	1	NICKEL 100 μ " MIN.
1	NUT	BRASS	1	NICKEL 100 μ " MIN.

Farnell # 583534

製圖	DRAWN	TOLERANCE		品名		日期	DATE	版次	REV.
		.X	± 0.2	13-29-7 (50 Ω)					
檢圖	CHECK	.XX	± 0.1	單位	mm(in)	DWG.NO.		13-0210	
		.XXX	± 0.05	比例	SCALE	佳楠精密電子股份有限公司			
認定	APPROVAL	ANGLE	$\pm 5^\circ$	4:1		CHIN NAN PRECISION ELECTRONICS CO.,LTD.			