

SYNCHRONOUS SWITCHMODE, LI-ION AND LI-POL CHARGE MANAGEMENT IC WITH INTEGRATED POWERFETS (bqSWITCHER™)

FEATURES

- **Ideal For High-Efficient Charger Designs For Single-, Two- or Three-Cell Li-Ion and Li-Pol Battery Packs**
- **Integrated Synchronous Fixed-Frequency PWM Controller Operating at 1.1 MHz with 0 to 100% Duty Cycle**
- **Integrated PowerFETs For Up To 2-A Charge Rate**
- **High-Accuracy Voltage and Current Regulation**
- **Available In Both Stand-Alone (Built-In Charge Management and Control) and System-Controlled (Under System Command) Versions**
- **Status Outputs For LED or Host Processor Interface Indicates Charge-In-Progress, Charge Completion, Fault, and AC-Adapter Present Conditions**
- **20-V Maximum Voltage Rating on IN and OUT Pins**
- **High-Side Current Sensing**
- **Optional Battery Temperature Monitoring**
- **Automatic Sleep Mode for Low Power Consumption**
- **System-Controlled Version Can Be Used In NiMH and NiCd Applications**
- **Uses Ceramic Capacitors**
- **Reverse Leakage Protection Prevents Battery Drainage**
- **Thermal Shutdown and Protection**
- **Built-In Battery Detection**

DESCRIPTION

The bqSWITCHER™ series are highly integrated Li-ion and Li-polymer switch-mode charge management devices targeted at a wide range of portable applications. The bqSWITCHER™ series offers integrated synchronous PWM controller and power FETs, high-accuracy current and voltage regulation, charge preconditioning, charge status, and charge termination, in a small, thermally enhanced QFN package. The system-controlled version provides additional inputs for full charge management under system control.

The bqSWITCHER charges the battery in three phases: conditioning, constant current, and constant voltage. Charge is terminated based on user-selectable minimum current level. A programmable charge timer provides a safety backup for charge termination. The bqSWITCHER automatically re-starts the charge cycle if the battery voltage falls below an internal threshold. The bqSWITCHER automatically enters sleep mode when V_{CC} supply is removed.

APPLICATIONS

- **Handheld Products**
- **Portable Media Players**
- **Industrial and Medical Equipment**
- **Portable Equipment**



Please be aware that an important notice concerning availability, standard warranty, and use in critical applications of Texas Instruments semiconductor products and disclaimers thereto appears at the end of this data sheet.

bqSWITCHER™ and PowerPAD™ are trademarks of Texas Instruments.

PRODUCTION DATA information is current as of publication date. Products conform to specifications per the terms of Texas Instruments standard warranty. Production processing does not necessarily include testing of all parameters.

bq24100, bq24103, bq24105 bq24108, bq24113, bq24115

SLUS606B – JUNE 2004 – REVISED NOVEMBER 2004



These devices have limited built-in ESD protection. The leads should be shorted together or the device placed in conductive foam during storage or handling to prevent electrostatic damage to the MOS gates. PowerPAD should act as the *star ground* between PGND and VSS. See Layout section for more details.

TYPICAL SINGLE CELL Li-ION STAND-ALONE CHARGER

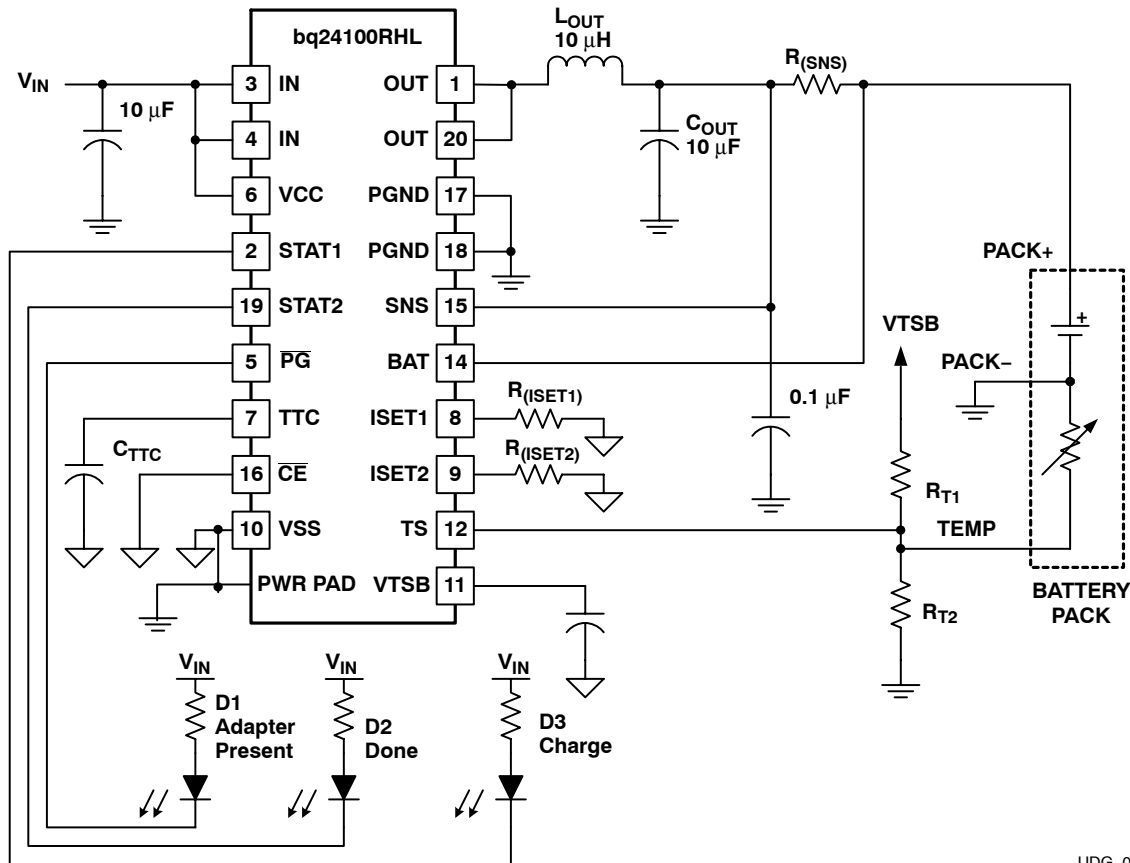

UDG-04033

ORDERING INFORMATION

T _J	CHARGE REGULATION VOLTAGE (V)	INTENDED APPLICATION	PART NUMBER ⁽¹⁾⁽²⁾	MARKINGS
-40°C to 125°C	4.2	Stand-alone	bq24100RHLLR	CIA
	1 or 2 cells selectable (CELLS pin 4.2 or 8.4 V)	Stand-alone	bq24103RHLLR	CID
	Externally programmable (2.1 to 15.5 V)	Stand-alone	bq24105RHLLR	CIF
	4.2 (Blinking status pins)	Stand-alone	bq24108RHLLR	CIU
	1 or 2 cells selectable (CELLS pin 4.2 or 8.4 V)	System-controlled	bq24113RHLLR	CIJ
	Externally programmable (2.1 to 15.5 V)	System-controlled	bq24115RHLLR	CIL

⁽¹⁾ The RHL package is available taped and reeled only. Quantities are 3,000 devices per reel.

⁽²⁾ This product is RoHS compatible, including a lead concentration that does not exceed 0.1% of total product weight, and is suitable for use in specified lead-free soldering processes.

PACKAGE DISSIPATION RATINGS

PACKAGE	θ_{JA}	$T_A < 40^\circ\text{C}$ POWER RATING	DERATING FACTOR ABOVE $T_A = 40^\circ\text{C}$
RHL ⁽¹⁾	46.87 °C/W	1.81 W	0.021 W/°C

⁽¹⁾ This data is based on using the JEDEC High-K board, and the exposed die pad is connected to a copper pad on the board. This is connected to the ground plane by a 2x3 via matrix.

ABSOLUTE MAXIMUM RATINGS⁽¹⁾

			UNIT
Supply voltage range, (with respect to V_{SS})	IN, VCC	20	V
Input voltage range, (with respect to V_{SS} and PGND)	STAT1, STAT2, $\overline{\text{PG}}$, $\overline{\text{CE}}$, CELLS, SNS, BAT	-0.3 to 20	
	OUT	-0.7 to 20	
	CMODE, TS, TTC	7	
	VTSB	3.6	
	ISET1, ISET2	3.3	
Voltage difference between SNS and BAT inputs ($V_{SNS} - V_{BAT}$)		± 1	
Output sink	STAT1, STAT2, $\overline{\text{PG}}$	10	mA
Output current (average)	OUT	2.2	A
Operating free-air temperature range, T_A		-40 to 85	°C
Junction temperature range, T_J		-40 to 125	
Storage temperature, T_{stg}		-65 to 150	
Lead temperature 1,6 mm (1/16 inch) from case for 10 seconds		300	

⁽¹⁾ Stresses beyond those listed under “absolute maximum ratings” may cause permanent damage to the device. These are stress ratings only, and functional operation of the device at these or any other conditions beyond those indicated under “recommended operating conditions” is not implied. Exposure to absolute-maximum-rated conditions for extended periods may affect device reliability.

RECOMMENDED OPERATING CONDITIONS

	MIN	NOM	MAX	UNIT
Supply voltage, V_{CC} and IN (Tie together)	4.35 [†]		16.0 [‡]	V
Operating junction temperature range, T_J	-40		125	°C

[†] The IC continues to operate below V_{min} , to 3.5 V, but the specifications are not tested nor guaranteed.

[‡] The inherent switching noise voltage spikes should not exceed the absolute maximum rating on either the IN or OUT pins. A *tight* layout minimizes switching noise.

bq24100, bq24103, bq24105
bq24108, bq24113, bq24115

SLUS606B – JUNE 2004 – REVISED NOVEMBER 2004

ELECTRICAL CHARACTERISTICS

T_J = 0°C to 125°C and recommended supply voltage range (unless otherwise stated)

PARAMETER		TEST CONDITIONS	MIN	TYP	MAX	UNIT
INPUT CURRENTS						
I _{VCC(VCC)}	V _{CC} supply current	V _{CC} > V _{CC(min)} , PWM switching		10		mA
		V _{CC} > V _{CC(min)} , PWM NOT switching			5	
		V _{CC} > V _{CC(min)} , \overline{CE} = HIGH				315
I _(SLP)	Battery discharge sleep current, (SNS, BAT, OUT, FB pins)	0°C ≤ T _J ≤ 65°C, V _{I(BAT)} = 4.2 V V _{CC} < V _(SLP) or V _{CC} > V _(SLP) but not in charge			3.5	μA
		0°C ≤ T _J ≤ 65°C, V _{I(BAT)} = 8.4 V V _{CC} < V _(SLP) or V _{CC} > V _(SLP) but not in charge			5.5	
		0°C ≤ T _J ≤ 65°C, V _{I(BAT)} = 12.6 V V _{CC} < V _(SLP) or V _{CC} > V _(SLP) but not in charge			7.7	
VOLTAGE REGULATION						
V _{O(REG)}	Output voltage, bq24103/13	CELLS = Low, in voltage regulation		4.2		V
		CELLS = High, in voltage regulation		8.4		
	Output voltage, bq24100/08	Operating in voltage regulation		4.2		
V _{I(BAT)}	Feedback regulation REF for bq24105/15 only (W/FB)	I _{I(BAT)} = 25 nA typical into pin		2.1		V
	Voltage regulation accuracy	T _A = 25°C	-0.5%		0.5%	
			-1%		1%	
CURRENT REGULATION – FAST CHARGE						
I _{O(CHARGE)}	Output current range of converter	V _{LOWV} ≤ V _{I(BAT)} < V _{O(REG)} , V _(VCC) - V _{I(BAT)} > V _(DO-MAX)	150		2000	mA
V _{I(REG)}	Voltage regulated across R _{SNS} – Accuracy	100 mV ≤ V _{I(REG)} ≤ 200 mV, $V_{I(REG)} = \frac{1V}{RSET1} \times 1000$, Programmed Where 5 kΩ ≤ RSET1 ≤ 10kΩ, Select RSET1 to program V _{I(REG)} , V _{I(REG)(measured)} = I _{O(CHARGE)} + R _{SNS} (-10% to +10% excludes errors due to RSET1 and R _{SNS} tolerances)	-10%		10%	
V _(ISET1)	Output current set voltage	V _(LOWV) ≤ V _{I(BAT)} ≤ V _{O(REG)} V _(VCC) ≥ V _{I(BAT)} + V _(DO-MAX) ,		1		V
K _(ISET1)	Output current set factor	V _{LOWV} ≤ V _{I(BAT)} < V _{O(REG)} V _(VCC) ≥ V _{I(BAT)} + V _(DO-MAX) ,		1000		V/A
PRECHARGE AND SHORT-CIRCUIT CURRENT REGULATION						
V _{LOWV}	Precharge to fast-charge transition voltage threshold, BAT, bq24100/03/05/08 ICs only		68	71.4	75	%V _{O(REG)}
t	Deglitch time for precharge to fast charge transition	Rising voltage; t _{RISE} , t _{FALL} = 100 ns, 2-mV overdrive	20	30	40	ms
I _{O(PRECHG)}	Precharge range	V _{I(BAT)} < V _{LOWV} , t < t _{PRECHG}	15		200	mA
V _(ISET2)	Precharge set voltage, ISET2	V _{I(BAT)} < V _{LOWV} , t < t _{PRECHG}		100		mV
K _(ISET2)	Precharge current set factor			1000		V/A

ELECTRICAL CHARACTERISTICS (continued)

T_J = 0°C to 125°C and recommended supply voltage range (unless otherwise stated)

PARAMETER		TEST CONDITIONS	MIN	TYP	MAX	UNIT
V _{IREG-PRE}	Voltage regulated across R _{SNS} – Accuracy	100 mV ≤ V _{IREG-PRE} ≤ 100 mV, $V_{IREG-PRE} = \frac{0.1V}{R_{SET2}} \times 1000,$ (PGM) Where 1.2 kΩ ≤ R _{SET2} ≤ 10kΩ, Select R _{SET1} to program V _{IREG-PRE} , V _{IREG-PRE} (Measured) = I _{OPRE-CHG} × R _{SNS} (-20% to +20% excludes errors due to R _{SET1} and R _{SNS} tolerances)	-20%		20%	
CHARGE TERMINATION (CURRENT TAPER) DETECTION						
I _{TERM}	Charge current termination detection range	V _{I(BAT)} > V _{RCH}	15		200	mA
V _{TERM}	Charge termination detection set voltage, I _{SET2}	V _{I(BAT)} > V _{RCH}		100		mV
K _(ISET2)	Termination current set factor			1000		V/A
	Charger termination accuracy	V _{I(BAT)} > V _{RCH}	-20%		20%	
t _{dg-TERM}	Deglitch time for charge termination	Both rising and falling, 2-mV overdrive t _{RISE} , t _{FALL} = 100 ns	20	30	40	ms
TEMPERATURE COMPARATOR AND V_{TSB} BIAS REGULATOR						
V _{LTF}	Cold temperature threshold, TS		72.8	73.5	74.2	% V _{O(VTSB)}
V _{HTF}	Hot temperature threshold, TS		33.7	34.4	35.1	
V _{TCO}	Cutoff temperature threshold, TS		28.7	29.3	29.9	
	LTF hysteresis		0.5	1.0	1.5	
t _{dg-TS}	Deglitch time for temperature fault, TS	Both rising and falling, 2-mV overdrive t _{RISE} , t _{FALL} = 100 ns	20	30	40	ms
V _{O(VTSB)}	TS bias output voltage	V _{CC} > V _{IN(min)} , I _(VTSB) = 10 mA 0.1 μF ≤ C _{O(VTSB)} ≤ 1 μF,		3.15		V
V _{O(VTSB)}	TS bias voltage regulation accuracy	V _{CC} > V _{IN(min)} , I _(VTSB) = 10 mA 0.1 μF ≤ C _{O(VTSB)} ≤ 1 μF,	-10%		10%	
BATTERY RECHARGE THRESHOLD						
V _{RCH}	Recharge threshold voltage	Below V _{O(REG)}	75	100	125	mV/cell
t _{dg-RCH}	Deglitch time	V _{I(BAT)} < decreasing below threshold, t _{FALL} = 100 ns 10-mV overdrive	20	30	40	ms
STAT1, STAT2, AND PG OUTPUTS						
V _{OL(STATx)}	Low-level output saturation voltage, STAT _x	I _O = 5 mA			0.5	V
V _{OL(PG)}	Low-level output saturation voltage, PG	I _O = 10 mA			0.1	
CE CMODE, CELLS INPUTS						
V _{IL}	Low-level input voltage	I _{IL} = 5 μA	0.0		0.4	V
V _{IH}	High-level input voltage	I _{IH} = 20 μA	1.3		V _{CC}	

bq24100, bq24103, bq24105
bq24108, bq24113, bq24115

SLUS606B – JUNE 2004 – REVISED NOVEMBER 2004

ELECTRICAL CHARACTERISTICS (continued)

T_J = 0°C to 125°C and recommended supply voltage range (unless otherwise stated)

PARAMETER		TEST CONDITIONS	MIN	TYP	MAX	UNIT
TTC INPUT						
t _{PRECHG}	Precharge timer		1440	1800	2160	s
t _{CHARGE}	Programmable charge timer range	t _(CHG) = C _(TTC) × K _(TTC)	25		572	minutes
	Charge timer accuracy	0.01 μF ≤ C _(TTC) ≤ 0.18 μF	-10%		10%	
K _{TTC}	Timer multiplier			2.6		min/nF
C _{TTC}	Charge time capacitor range		0.01		0.22	μF
V _{TTC_EN}	TTC enable threshold voltage	V _(TTC) rising		200		mV
SLEEP COMPARATOR						
V _{SLP-ENT}	Sleep-mode entry threshold	2.3 V ≤ V _{I(OUT)} ≤ V _{OREG} , for 1 or 2 cells	V _{CC} ≤ +5 mV		V _{CC} ≤ +75mV	V
		V _{I(OUT)} = 12.6 V, R _{IN} = 1 kΩ (1) bq24105/15	V _{CC} ≤ -4 mV		V _{CC} ≤ +73mV	
V _{SLP-EXIT}	Sleep-mode exit hysteresis,	2.3 V ≤ V _{I(OUT)} ≤ V _{OREG}	40		160	mV
t _{dg-SLP}	Deglitch time for sleep mode	V _{CC} decreasing below threshold, t _{FALL} = 100 ns, 10-mV overdrive, PMOS turns off		5		μs
		V _{CC} decreasing below threshold, t _{FALL} = 100 ns, 10-mV overdrive, STATx pins turn off	20	30	40	ms
UVLO						
V _{UVLO-ON}	IC active threshold voltage	V _{CC} rising	3.15	3.30	3.50	V
	IC active hysteresis	V _{CC} falling	120	150		mV
PWM						
	Internal P-channel MOSFET on-resistance	7 V ≤ V _{CC} ≤ V _{CC(max)}			400	mΩ
		4.5 V ≤ V _{CC} ≤ 7 V			500	
	Internal N-channel MOSFET on-resistance	7 V ≤ V _{CC} ≤ V _{CC(max)}			130	mΩ
		4.5 V ≤ V _{CC} ≤ 7 V			150	
f _{OSC}	Oscillator frequency			1.1		MHz
	Frequency accuracy		-9%		9%	
D _{MAX}	Maximum duty cycle				100%	
D _{MIN}	Minimum duty cycle		0%			
t _{TOD}	Switching delay time (turn on)			20		ns
t _{syncmin}	Minimum synchronous FET on time			60		ns
	Synchronous FET minimum current-off threshold (2)		50		400	mA

ELECTRICAL CHARACTERISTICS (continued)

T_J = 0°C to 125°C and recommended supply voltage range (unless otherwise stated)

PARAMETER		TEST CONDITIONS	MIN	TYP	MAX	UNIT
BATTERY DETECTION						
I _{DETECT}	Battery detection current during time-out fault	V _{I(BAT)} < V _{O(REG)} - V _{RCH}		2		mA
I _{DISCHRG1}	Discharge current	V _{SHORT} < V _{I(BAT)} < V _{O(REG)} - V _{RCH}		400		μA
t _{DISCHRG1}	Discharge time	V _{SHORT} < V _{I(BAT)} < V _{O(REG)} - V _{RCH}		1		s
I _{WAKE}	Wake current	V _{SHORT} < V _{I(BAT)} < V _{O(REG)} - V _{RCH}		2		mA
t _{WAKE}	Wake time	V _{SHORT} < V _{I(BAT)} < V _{O(REG)} - V _{RCH}		0.5		s
I _{DISCHRG2}	Termination discharge current	Begins after termination detected, V _{I(BAT)} ≤ V _{O(REG)}		400		μA
t _{DISCHRG2}	Termination time			262		ms
OUTPUT CAPACITOR						
C _{OUT}	Required output ceramic capacitor range from SNS to PGND, between inductor and R _{SNS}		4.7	10	47	μF
C _{SNS}	Required SNS capacitor (ceramic) at SNS pin			0.1		μF
PROTECTION						
V _{OVP}	OVP threshold voltage	Threshold over V _{O(REG)} to turn-off P-channel MOSFET, STAT1, and STAT2 during charge or termination states	110	117	121	%V _{O(REG)}
I _{LIMIT}	Cycle-by-cycle current limit		2.6	3.6	4.5	A
V _{SHORT}	Short-circuit voltage threshold, BAT	V _{I(BAT)} falling	1.95	2.00	2.05	V/cell
I _{SHORT}	Short-circuit current	V _{I(BAT)} ≤ V _{SHORT}	35		65	mA
T _{SHTDWN}	Thermal trip			165		°C
	Thermal hysteresis			10		

(1) For bq24105 and bq24115 only. R_{IN} is connected between IN and PGND pins and needed to ensure sleep entry.

(2) N-channel always turns on for ~60 ns and then turns off if current is too low.

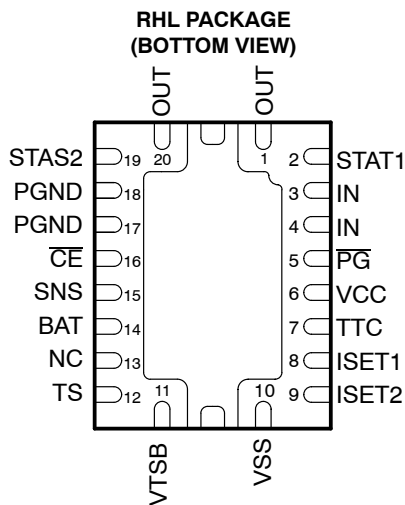

bq24100, bq24103, bq24105 bq24108, bq24113, bq24115

SLUS606B – JUNE 2004 – REVISED NOVEMBER 2004

TERMINAL FUNCTIONS

NAME	TERMINAL					I/O	Description
	bq24100 bq24108	bq24103	bq24105	bq24113	bq24115		
BAT	14	14	14	14	14	I	Battery voltage sense input. Bypass it with a capacitor to PGND if there are long inductive leads to battery.
\overline{CE}	16	16	16	16	16	I	Charger enable input. This active low input, if set high, suspends charge and places the device in the low-power sleep mode. Do not pull up this input to VTSB.
CELLS		13		13		I	Available on parts with fixed output voltage. Ground or float for single cell operation (4.2 V). For two cells operation (8.4 V) pull up this pin with a resistor to V _{CC} .
CMODE				7	7	I	Charge mode selection: low for precharge as set by ISET2 pin and high (pull up to VTSB or <7 V) for fast charge as set by ISET1.
FB			13		13	I	Output voltage analog feedback adjustment. Connect the output of a resistive voltage divider powered from the battery terminals to this node to adjust the output battery voltage regulation.
IN	3, 4	3, 4	3, 4	3, 4	3, 4	I	Charger input voltage.
ISET1	8	8	8	8	8	I/O	Charger current set point 1 (fast charge). Use a resistor to ground to set this value.
ISET2	9	9	9	9	9	I/O	Charge current set point 2 (precharge and termination), set by a resistor connected to ground. A low-level CMODE signal selects the ISET2 charge rate, but if the battery voltage reaches the regulation set point, bqSWITCHER changes to voltage regulation regardless of CMODE input.
N/C	13			19	19	–	No connection. This pin must be left floating in the application.
OUT	1	1	1	1	1	O	Charge current output inductor connection.
	20	20	20	20	20	O	
\overline{PG}	5	5	5	5	5	O	Power good status output (open drain). The transistor turns on when a valid V _{CC} is detected. It is turned off in the sleep mode. \overline{PG} can be used to drive a LED or communicate with a host processor.
PGND	17,18	17,18	17,18	17,18	17, 18		Power ground input
SNS	15	15	15	15	15	I	Charge current-sense input. Battery current is sensed via the voltage drop developed on this pin by an external sense resistor in series with the battery pack. A 0.1- μ F capacitor to PGND is required.
STAT1	2	2	2	2	2	O	Charge status 1 (open-drain output). When the transistor turns on indicates charge in process. When it is off and with the condition of STAT2 indicates various charger conditions (See Table 1)
STAT2	19	19	19			O	Charge status 2 (open-drain output). When the transistor turns on indicates charge is done. When it is off and with the condition of STAT1 indicates various charger conditions (See Table 1)
TS	12	12	12	12	12	I	Temperature sense input. This input monitors its voltage against an internal threshold to determine if charging is allowed. Use an NTC thermistor and a voltage divider powered from VTSB to develop this voltage. (See Figure 7)
TTC	7	7	7			I	Timer and termination control. Connect a capacitor from this node to GND to set the bqSWITCHER timer. When this input is low the timer and termination detection are disabled.
VCC	6	6	6	6	6	I	Analog device input
VSS	10	10	10	10	10		Analog ground input
VTSB	11	11	11	11	11	O	TS internal bias regulator voltage. Connect capacitor (with a value between a 0.1- μ F and 1- μ F) between this output and VSS.
Exposed Thermal Pad	Pad	Pad	Pad	Pad	Pad	–	There is an internal electrical connection between the exposed thermal pad and VSS. The exposed thermal pad must be connected to the same potential as the VSS pin on the printed circuit board. The power pad can be used as a star ground connection between V _{SS} and PGND. A common ground plane may be used. VSS pin must be connected to ground at all times.

FUNCTIONAL BLOCK DIAGRAM

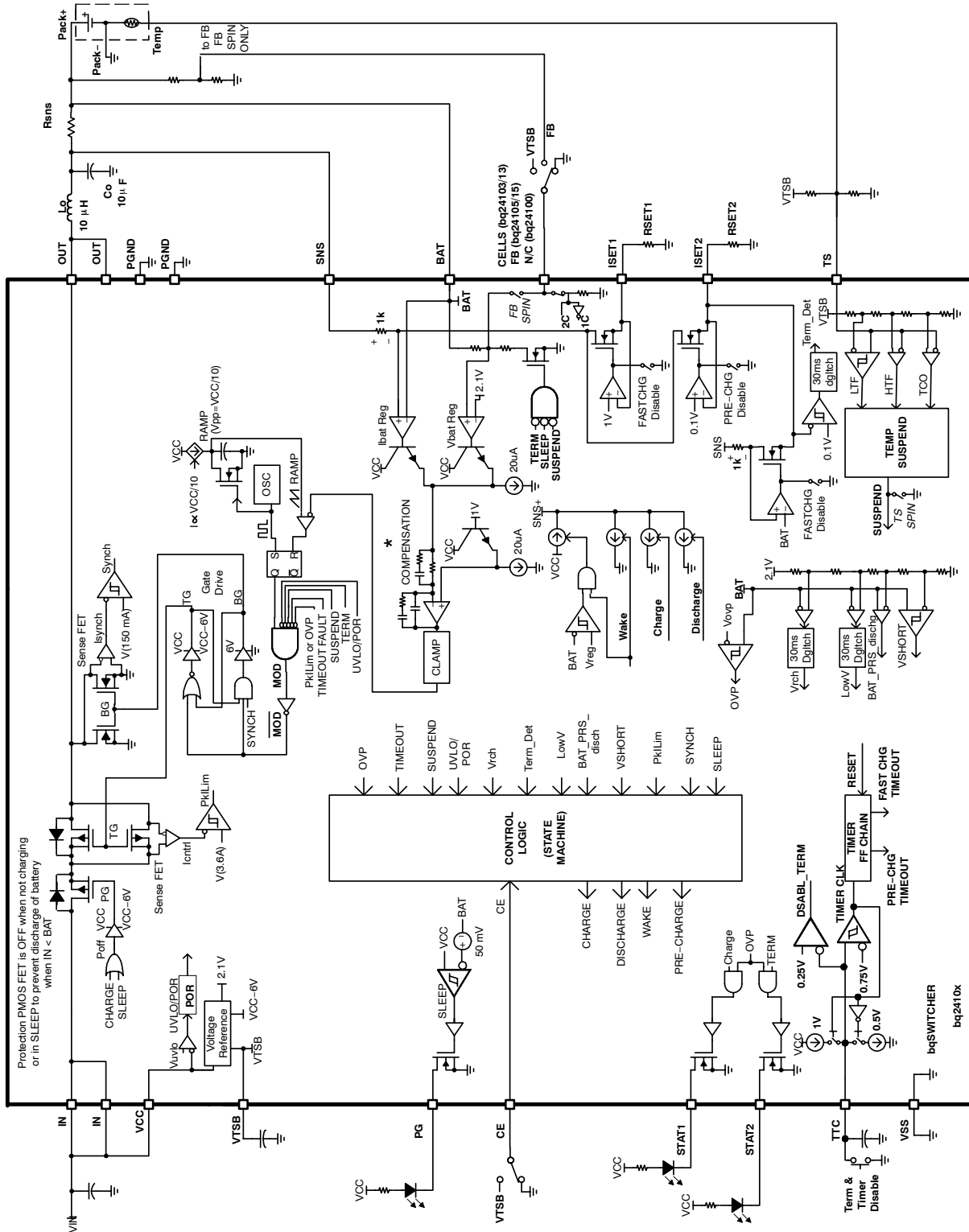

*Patent Pending #36889
bq2410x

TYPICAL CHARACTERISTICS

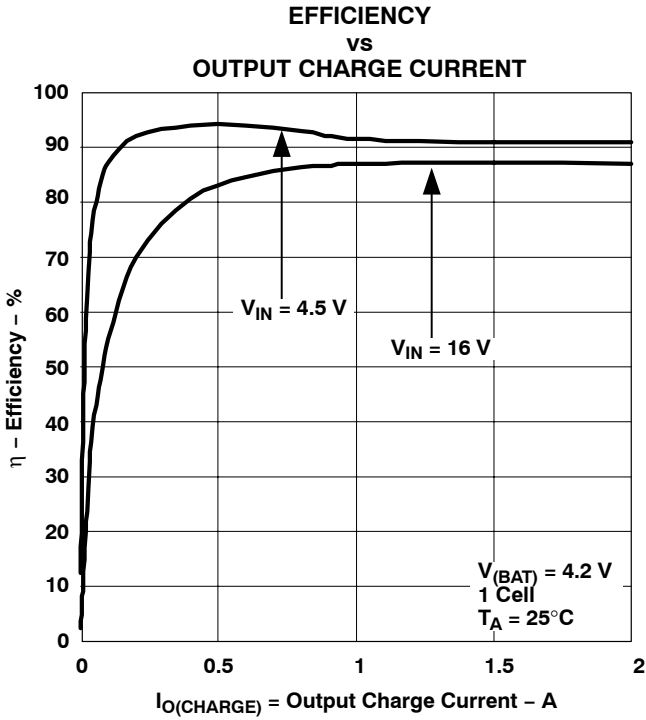

Figure 1

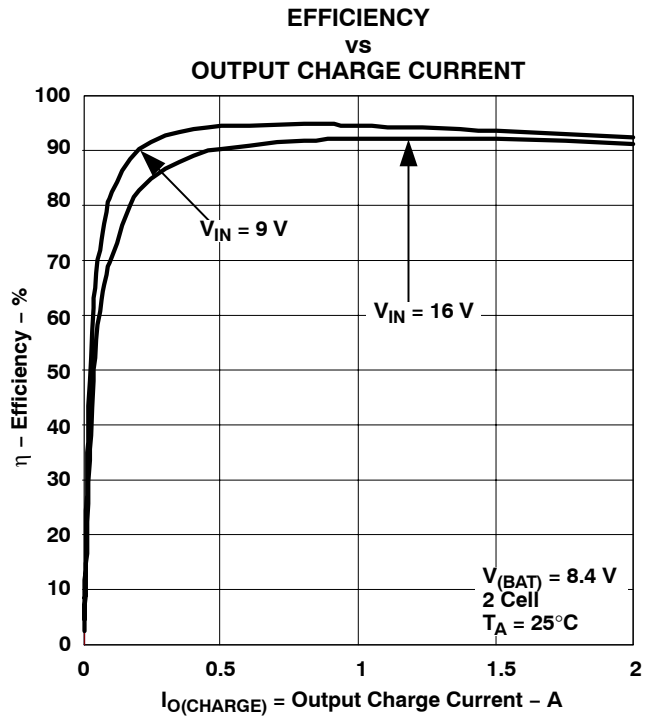
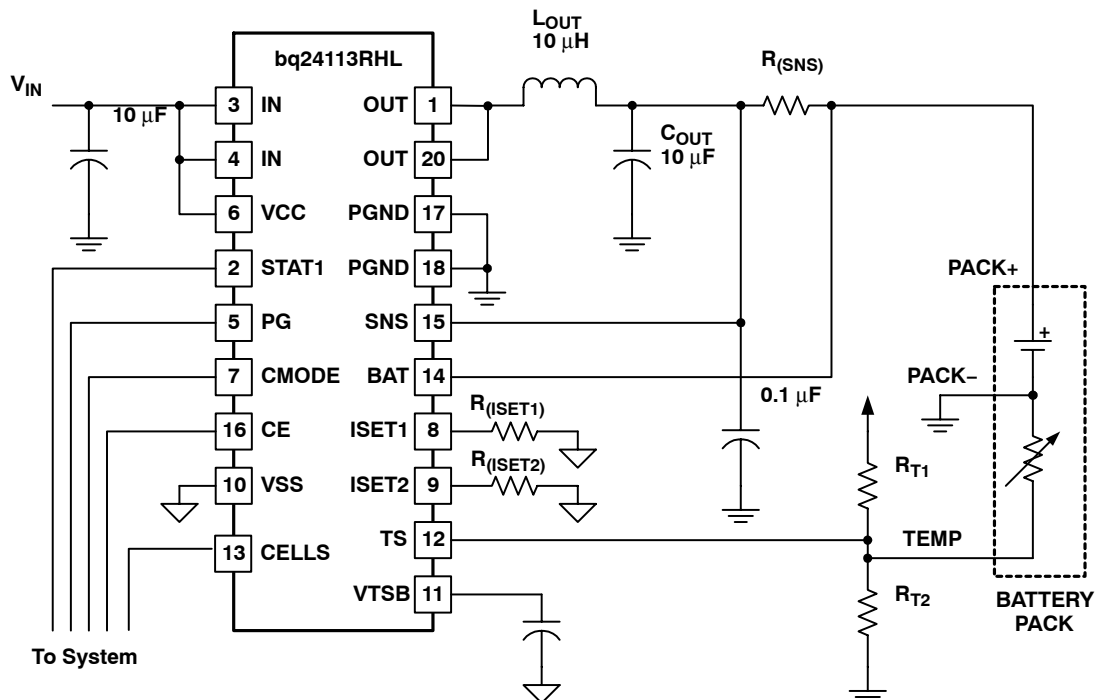

Figure 2



UDG-04035

Figure 3. Typical Application Circuit (System-Controlled Version)

APPLICATION INFORMATION

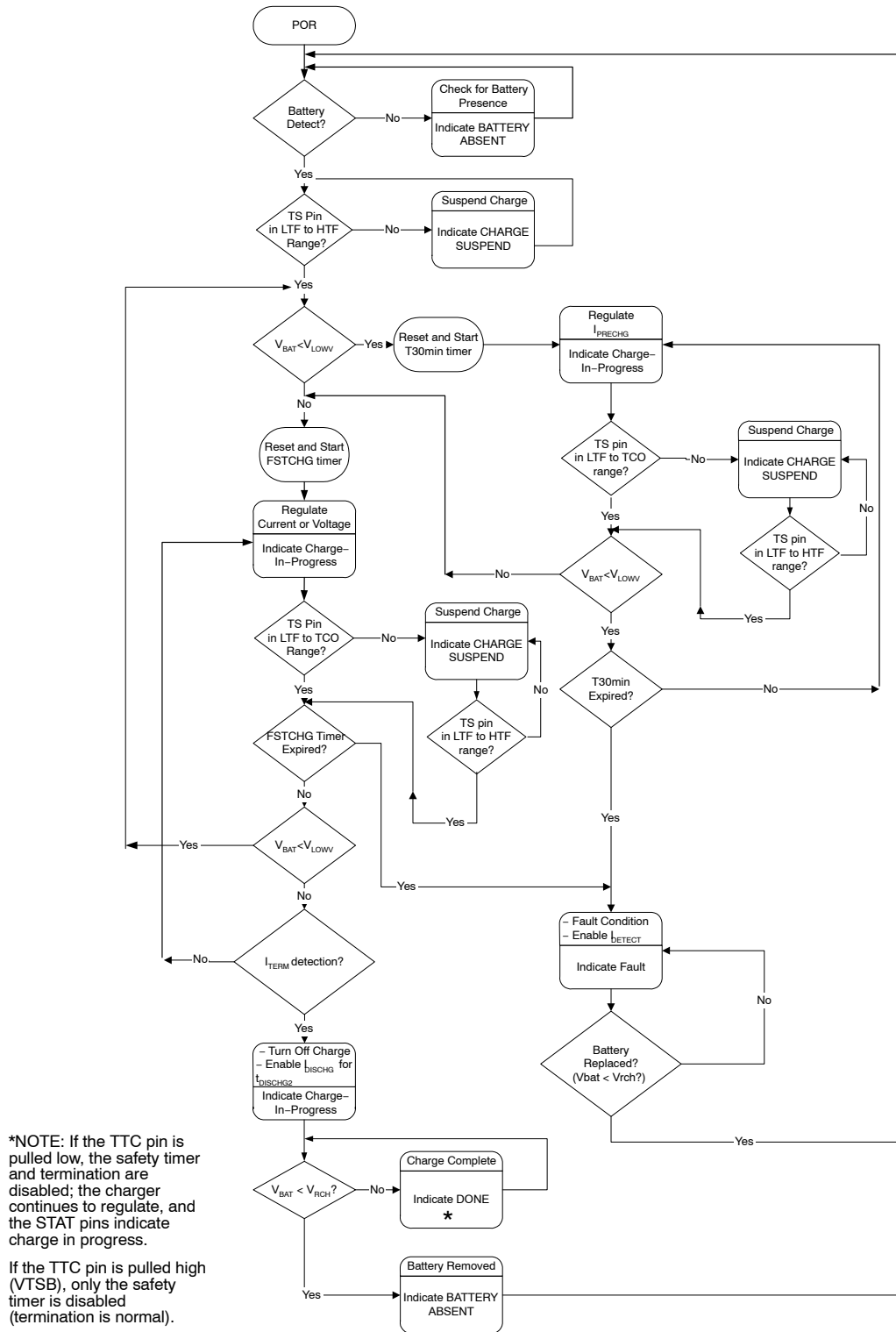

Figure 4. Stand-Alone Version Operational Flow Chart

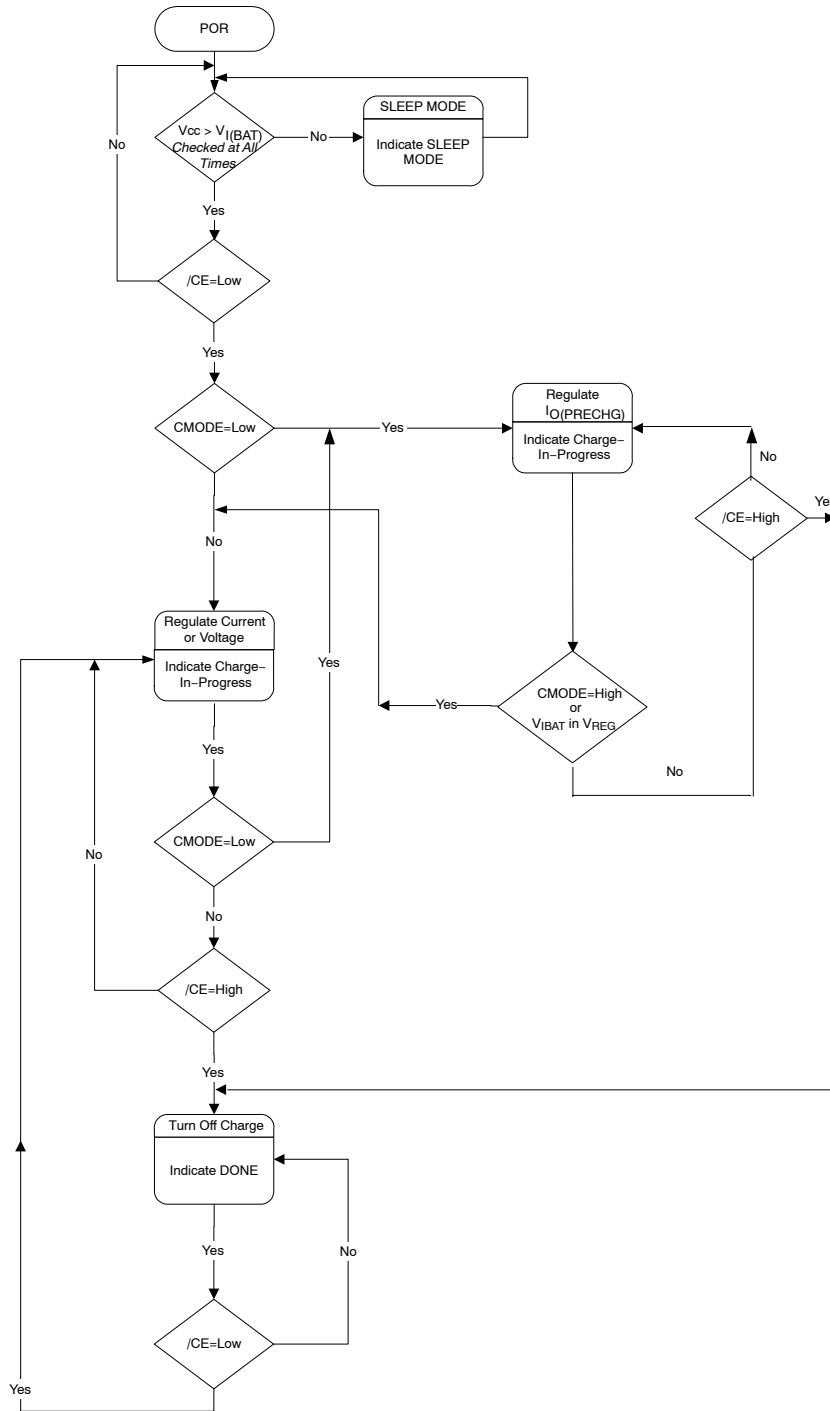
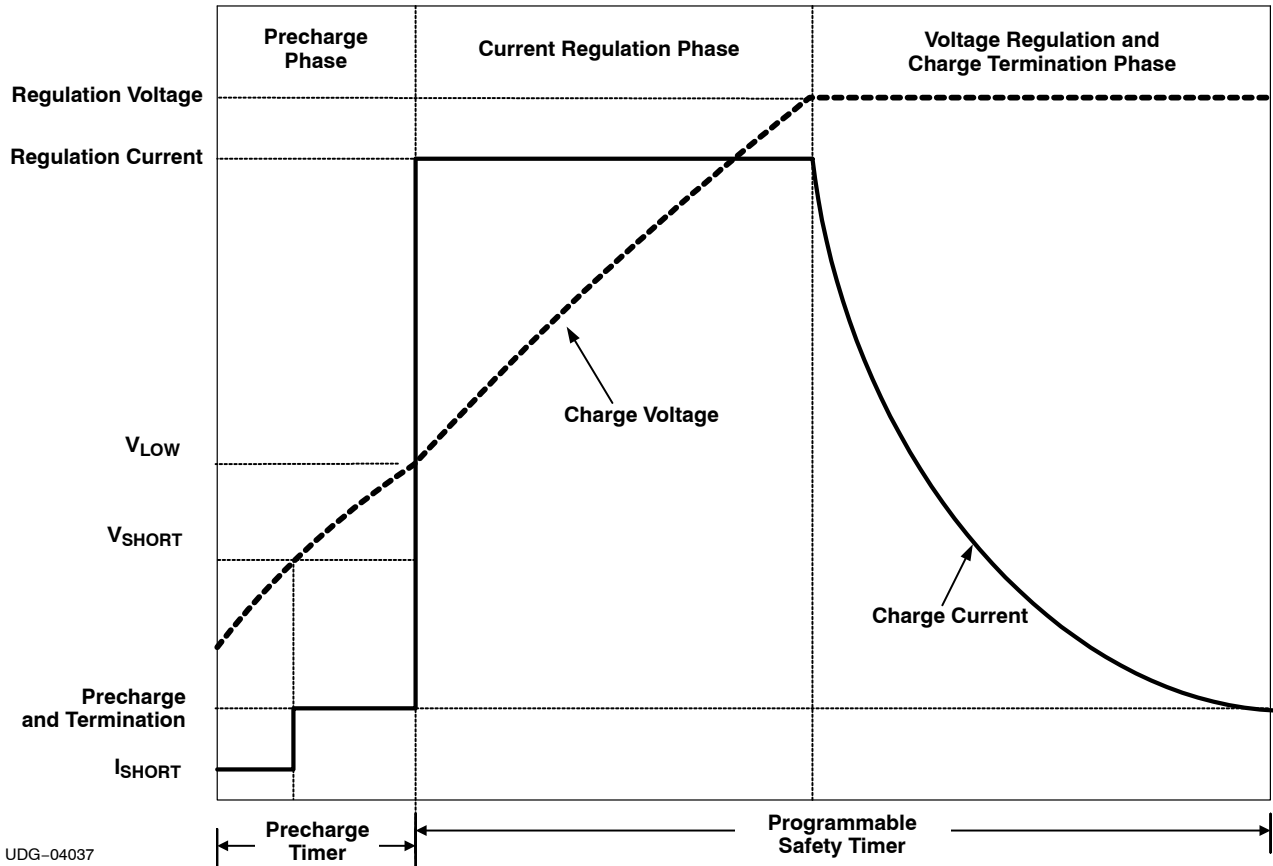

Figure 5. System-Controlled Operational Flow Chart

FUNCTIONAL DESCRIPTION FOR STANDALONE VERSION (bq2410x)

The bqSWITCHER™ supports a precision Li-ion or Li-polymer charging system for single-, two- or three-cell applications. See Figure 4 and Figure 5 for operational flow charts and Figure 6 for a typical charge profile.



UDG-04037

Figure 6. Typical Charging Profile

Temperature Qualification

The bqSWITCHER continuously monitors battery temperature by measuring the voltage between the TS pin and VSS pin. A negative temperature coefficient thermistor (NTC) and an external voltage divider typically develop this voltage. The bqSWITCHER compares this voltage against its internal thresholds to determine if charging is allowed. To initiate a charge cycle, the battery temperature must be within the $V_{(LTF)}$ -to- $V_{(HTF)}$ thresholds. If battery temperature is outside of this range, the bqSWITCHER suspends charge and waits until the battery temperature is within the $V_{(LTF)}$ -to- $V_{(HTF)}$ range. During the charge cycle (both precharge and fast charge), the battery temperature must be within the $V_{(LTF)}$ -to- $V_{(TCO)}$ thresholds. If battery temperature is outside of this range, the bqSWITCHER suspends charge and waits until the battery temperature is within the $V_{(LTF)}$ -to- $V_{(HTF)}$ range. The bqSWITCHER suspends charge by turning off the PWM and holding the timer value (i.e., timers are not reset during a suspend condition). Note that the bias for the external resistor divider is provided from the VTSB output. Applying a constant voltage between the $V_{(LTF)}$ -to- $V_{(HTF)}$ thresholds to the TS pin disables the temperature-sensing feature.

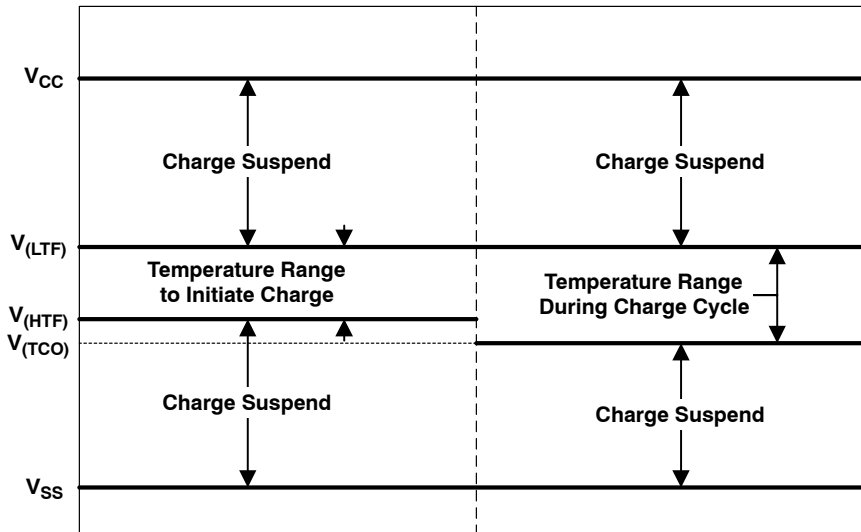

Figure 7. TS Pin Thresholds

Battery Preconditioning (Precharge)

On power up, if the battery voltage is below the V_{LOWV} threshold, the bqSWITCHER applies a precharge current, I_{PRECHG}, to the battery. This feature revives deeply discharged cells. The bqSWITCHER activates a safety timer, t_{PRECHG}, during the conditioning phase. If the V_{LOWV} threshold is not reached within the timer period, the bqSWITCHER turns off the charger and enunciates FAULT on the STATx pins. In the case of a FAULT condition, the bqSWITCHER reduces the current to I_{DETECT}. I_{DETECT} is used to detect a battery replacement condition. Fault condition is cleared by POR or battery replacement.

The magnitude of the precharge current, I_{O(PRECHG)}, is determined by the value of programming resistor, R_(ISET2), connected to the ISET2 pin.

$$I_{O(PRECHG)} = \frac{K_{(ISET2)} \times V_{(ISET2)}}{(R_{(ISET2)} \times R_{(SNS)})} \tag{1}$$

where

- R_{SNS} is the external current-sense resistor
- V_(ISET2) is the output voltage of the ISET2 pin
- K_(ISET2) is the V/A gain factor
- V_(ISET2) and K_(ISET2) are specified in the Electrical Characteristics table.

Battery Charge Current

The battery charge current, I_{O(CHARGE)}, is established by setting the external sense resistor, R_(SNS), and the resistor, R_(ISET1), connected to the ISET1 pin.

In order to set the current, first choose R_(SNS) based on the regulation threshold V_{IREG} across this resistor. Let V_{IREG} = 100 mV to start and calculate the R_{SNS} value needed.

$$R_{(SNS)} = \frac{V_{IREG}}{I_{OCHARGE}} \tag{2}$$

If this value is not a standard sense resistor value, choose the next larger value. Using the selected standard value, solve for $V_{I\text{REG}}$.

$$V_{I\text{REG}} = R_{(\text{SNS})} \times I_{\text{OCHARGE}} \quad (3)$$

The value of $R_{(\text{ISET1})}$ is then calculated based on the following equation:

$$R_{\text{SET1}} = \frac{K_{\text{ISET1}} \times V_{\text{ISET1}}}{I_{\text{OCHARGE}} \times R_{\text{SNS}}} = \frac{1000 \text{ V}}{V_{I\text{REG}}} \quad (4)$$

where

- $V_{I\text{REG}}$ is the voltage regulated across R_{SNS}
- I_{OCHARGE} is the battery charge current
- R_{SNS} is the external current sense resistor
- $V_{(\text{ISET1})}$ is the output voltage of the ISET1 pin
- $K(\text{ISET1})$ is the V/A gain factor (see electrical characteristics table)

The following provide a more detailed design procedure and example for this parameter:

1. Select the charge current.

Example:

- $I_{\text{OCHARGE}} = 2 \text{ A}$
- $I_{\text{OPRECHG}} = 200 \text{ mA}$

2. Select the sense resistor value. Ensure that the power rating of the sense resistor is not exceeded

Example:

- Let $V_{I\text{REG}} = 100 \text{ mV}$ (S/B from 100–200 mV)
- Solve for $R_{\text{SNS}} = \frac{V_{I\text{REG}}}{I_{\text{OCHARGE}}} = \frac{100 \text{ mV}}{2 \text{ A}} = 50 \text{ m}\Omega$
- Check availability for R_{SNS} . Use value that is equal (next larger value if not available).
- Check for power dissipation

$$P_{(\text{SNS})} = R_{(\text{SNS})} \times (I_{\text{OCHARGE}})^2 = 0.05 \Omega \times (2 \text{ A})^2 = 0.2 \text{ W} \quad (5)$$

- Select 0805 or 1206 size rated at 0.25 W

3. Determine $R_{(ISET1)}$.

- $V_{(ISET1)} = 1\text{ V}$
- $K_{(ISET1)} = 1000\text{ V/A}$

$$R_{(ISET1)} = \frac{K_{(ISET1)} \times V_{(ISET1)}}{R_{(SNS)} \times I_{OCHARGE}} = \frac{1000\text{ V/A} \times 1\text{ V}}{0.05\ \Omega \times 2\text{ A}} = 10\text{ k}\Omega \quad (6)$$

4. Determine $R_{(ISET2)}$

- $V_{(ISET2)} = 0.1\text{ V}$
- $K_{(ISET2)} = 1000\text{V/A}$

$$R_{(ISET2)} = \frac{K_{(ISET2)} \times V_{(ISET2)}}{R_{(SNS)} \times I_{OPRECHG}} = \frac{1000\text{ V/A} \times 0.1\text{ V}}{0.05\ \Omega \times 0.2\text{ A}} = 10\text{ k}\Omega \quad (7)$$

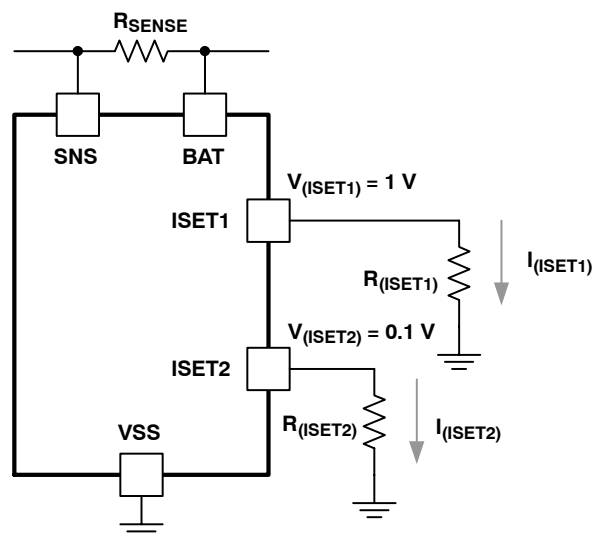

UDG-04036

Figure 8. Program Charge Current with $R_{(ISET1)}$ and $R_{(ISET2)}$

Battery Voltage Regulation

The voltage regulation feedback occurs through the BAT pin. This input is tied directly to the positive side of the battery pack. The bqSWITCHER monitors the battery-pack voltage between the BAT and VSS pins. The bqSWITCHER is offered in two fixed-voltage versions: 4.2 V and 8.4 V as selected by the CELLS input. A low or floating input on the CELLS selects single-cell mode (4.2 V) while a high-input selects two-cell mode.

For device options that include adjustable output voltage, the voltage regulation feedback is through the FB pin. A resistor divider is used from the battery output voltage to GND. BAT pin remains connected directly to the battery output voltage for current sensing with respect to SNS.

Charge Termination And Recharge

The bqSWITCHER monitors the charging current during the voltage regulation phase. Once the termination threshold, I_{TERM} , is detected, the bqSWITCHER terminates charge. The termination current level is selected by the value of programming resistor, $R_{(\text{ISET2})}$, connected to the ISET2 pin.

$$I_{\text{TERM}} = \frac{K_{(\text{ISET2})} \times V_{\text{TERM}}}{(R_{(\text{ISET2})} \times R_{(\text{SNS})})} \quad (8)$$

where

- $R_{(\text{SNS})}$ is the external current-sense resistor
- V_{TERM} is the output of the ISET2 pin
- $K_{(\text{ISET2})}$ is the A/V gain factor
- V_{TERM} and $K_{(\text{ISET2})}$ are specified in the Electrical Characteristics table

As a safety backup, the bqSWITCHER also provides a programmable charge timer. The charge time is programmed by the value of a capacitor connected between the TTC pin and GND by the following formula:

$$t_{\text{CHARGE}} = C_{(\text{TTC})} \times K_{(\text{TTC})} \quad (9)$$

where

- $C_{(\text{TTC})}$ is the capacitor connected to the TTC pin
- $K_{(\text{TTC})}$ is the multiplier

A new charge cycle is initiated when one of the following conditions are detected:

- The battery voltage falls below the V_{RCH} threshold
- Power-on reset (POR), if battery voltage is below the V_{RCH} threshold
- $\overline{\text{CE}}$ toggle
- TTC pin, described as follows.

In order to disable the charge termination and safety timer, the user can pull the TTC input below the $V_{\text{TTC_EN}}$ threshold. Going above this threshold enables the termination and safety timer features and also reset the timer. Tying TTC high to VTSB disables the safety timer only.

Sleep Mode

The bqSWITCHER enters the low-power sleep mode if the VCC pin is removed from the circuit. This feature prevents draining the battery during the absence of VCC.

Charge Status Outputs

The open-drain STAT1 and STAT2 outputs indicate various charger operations as shown in the following table. These status pins can be used to drive LEDs or communicate to the host processor. Note that OFF indicates that the open-drain transistor is turned off.

Table 1. Status Pins Summary

Charge State	STAT1	STAT2
Charge-in-progress	ON	OFF
Charge complete	OFF	ON
Charge suspend, timer fault, overvoltage, sleep mode, battery absent ⁽¹⁾	OFF	OFF

⁽¹⁾ bq2411x IC do not have timer fault or battery absent modes

Table 2. Status Pins Summary (bq24108 only)

Charge State	STAT1	STAT2
Battery absent	OFF	OFF
Charge-in-progress	ON	OFF
Charge complete	OFF	ON
Battery over discharge, $V_{I(BAT)} < V_{(SC)}$	ON/OFF (0.5 Hz)	OFF
Charge suspend, (due to TS pin and internal thermal protection)	ON/OFF (0.5 Hz)	OFF
Precharge timer fault	ON/OFF (0.5 Hz)	OFF
Fast charge timer fault	ON/OFF (0.5 Hz)	OFF
Sleep mode	OFF	OFF

\overline{PG} Output

The open-drain \overline{PG} (power good) indicates when the AC-to-DC adapter (i.e., V_{CC}) is present. The output turns ON when sleep-mode exit threshold, V_{SLP_EXIT} , is detected. This output is turned off in the sleep mode. The \overline{PG} pin can be used to drive an LED or communicate to the host processor.

\overline{CE} Input (Charge Enable)

The \overline{CE} digital input is used to disable or enable the charge process. A low-level signal on this pin enables the charge and a high-level V_{CC} signal disables the charge. A high-to-low transition on this pin also resets all timers and fault conditions. Note that the \overline{CE} pin cannot be pulled up to V_{TSB} voltage. This may create power-up issues.

Battery Absent Detection

For applications with removable battery packs, bqSWITCHER provides a battery absent detection scheme to reliably detect insertion and/or removal of battery packs.

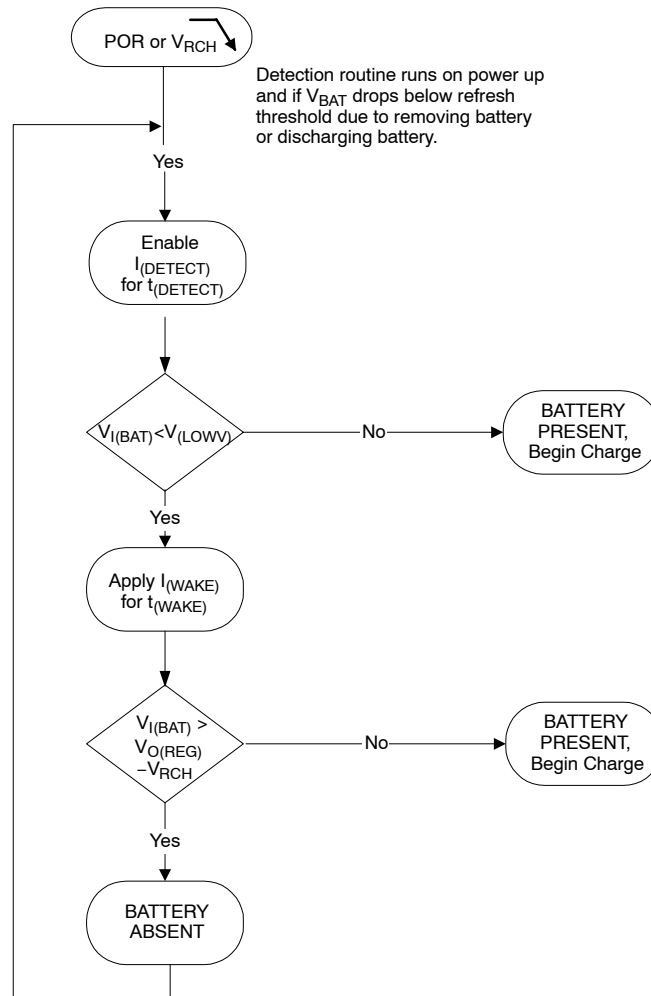

Figure 9. Battery Absent Detection for bq2410x ICs only

The voltage at the BAT pin is held above the battery recharge threshold, V_{RCH} , by the charged battery following fast charging. When the voltage at the BAT pin falls to the recharge threshold, either by a load on the battery or due to battery removal, the bqSWITCHER begins a battery absent detection test. This test involves enabling a detection current, I_{DETECT} , for a period of t_{DETECT} and checking to see if the battery voltage is below the precharge threshold, V_{LOWV} . Following this, the precharge current, $I_{OPRECHG}$ is applied for a period of t_{DETECT} and the battery voltage is checked again to ensure that it is above the recharge threshold. The purpose of this current is to attempt to *close* a battery pack with an open protector, if one is connected to the bqSWITCHER.

Passing both of the discharge and charging tests indicates a battery absent fault at the STAT pins. Failure of either test starts a new charge cycle. For the absent battery condition, the voltage on the BAT pin rises and falls between the V_{LOWV} and V_{OREG} thresholds indefinitely.

Timer Fault Recovery

As shown in Figure 5, bqSWITCHER provides a recovery method to deal with timer fault conditions. The following summarizes this method.

Condition #1

$V_{I(BAT)}$ above recharge threshold ($V_{OREG} - V_{RCH}$) and timeout fault occurs.

Recovery method: bqSWITCHER waits for the battery voltage to fall below the recharge threshold. This could happen as a result of a load on the battery, self-discharge or battery removal. Once the battery falls below the recharge threshold, the bqSWITCHER clears the fault and enters the battery absent detection routine. A POR or \overline{CE} or TTE toggle also clears the fault.

Condition #2

Charge voltage below recharge threshold (V_{RCH}) and timeout fault occurs

Recovery method: Under this scenario, the bqSWITCHER applies the I_{DETECT} current. This small current is used to detect a battery removal condition and remains on as long as the battery voltage stays below the recharge threshold. If the battery voltage goes above the recharge threshold, then the bqSWITCHER disables the I_{DETECT} current and executes the recovery method described for condition #1. Once the battery falls below the recharge threshold, the bqSWITCHER clears the fault and enters the battery absent detection routine. A POR or \overline{CE} toggle also clears the fault.

Output Overvoltage Protection (Applies To All Versions)

The bqSWITCHER provides a built-in overvoltage protection to protect the detect and other components against damages if the battery voltage gets too high, as when the battery is suddenly removed. When an overvoltage condition is detected, this feature turns off the PWM and STATx pins. The fault is cleared once V_{IBAT} drops to the recharge threshold ($V_{OREG} - V_{RCH}$).

FUNCTIONAL DESCRIPTION FOR SYSTEM-CONTROLLED VERSION (bq2411x)

For applications requiring charge management under the host system control, the bqSWITCHER (bq2411x) offers a number of control functions. The following section describes these functions.

Precharge And Fast Charge Control

A low-level signal on the CMODE pin forces the bqSWITCHER to charge at the precharge rate set on the ISET2 pin. A high-level signal forces charge at fast charge rate as set by the ISET1 pin. If the battery reaches the voltage regulation level, V_{OREG} , the bqSWITCHER transitions to voltage regulation phase regardless of the status of the CMODE input.

Charge Termination And Safety Timers

The charge timers and termination are disabled in the system-controlled versions of the bqSWITCHER. The host system can use the \overline{CE} input to enable or disable charge. When an overvoltage condition is detected, the charger process stops, and all power FETs are turned off.

Inductor, Capacitor, and Sense Resistor Selection Guidelines

The bqSWITCHER provides internal loop compensation. With this scheme, best stability occurs when LC resonant frequency, f_0 is approximately 16 kHz (8 kHz to 32 kHz). Equation (10) can be used to calculate the value of the output inductor and capacitor. Table 2 provides a summary of typical component values for various charge rates.

$$f_0 = \frac{1}{2\pi \times \sqrt{L_{OUT} \times C_{OUT}}} \quad (10)$$

Table 3. Output Components Summary

CHARGE CURRENT	0.5 A	1 A	2 A
Output inductor, L _{OUT}	22 μH	10 μH	4.7 μH
Output capacitor, C _{OUT}	4.7 μF	10 μF	22 μF (or 2 × 10 μH) ceramic
Sense resistor, R _(SNS)	0.2 Ω	0.1 Ω	0.05 Ω

THERMAL CONSIDERATIONS

The SWITCHER is packaged in a thermally enhanced MLP package. The package includes a thermal pad to provide an effective thermal contact between the IC and the printed circuit board (PCB). Full PCB design guidelines for this package are provided in the application note entitled: *QFN/SON PCB Attachment Application Note* (SLUA271).

The most common measure of package thermal performance is thermal impedance (θ_{JA}) measured (or modeled) from the chip junction to the air surrounding the package surface (ambient). The mathematical expression for θ_{JA} is:

$$\theta_{(JA)} = \frac{T_J - T_A}{P} \quad (11)$$

Where:

T_J = chip junction temperature

T_A = ambient temperature

P = device power dissipation

Factors that can greatly influence the measurement and calculation of θ_{JA} include:

- Whether or not the device is board mounted
- Trace size, composition, thickness, and geometry
- Orientation of the device (horizontal or vertical)
- Volume of the ambient air surrounding the device under test and airflow
- Whether other surfaces are in close proximity to the device being tested

The device power dissipation, P , is a function of the charge rate and the voltage drop across the internal power FET. It can be calculated from the following equation:

$$P = [V_{in} \times I_{in} - V_{bat} \times I_{bat}]$$

Due to the charge profile of Li-xx batteries, the maximum power dissipation is typically seen at the beginning of the charge cycle when the battery voltage is at its lowest. (See Figure 6.)

PCB LAYOUT CONSIDERATION

It is important to pay special attention to the PCB layout. The following provides some guidelines:

- To obtain optimal performance, the power input capacitors, connected from input to PGND should be placed as close as possible to the bqSWITCHER. The output inductor should be placed directly above the IC and the output capacitor connected between the inductor and PGND of the IC. The intent is to minimize the current path loop area from the OUT pin through the LC filter and back to the GND pin. The sense resistor should be adjacent to the junction of the inductor and output capacitor. Route the sense leads connected across the R_{sns} back to the IC, close to each other (minimize loop area) or on top of each other on adjacent layers (do not route the sense leads through a high-current path). Use an optional capacitor downstream from the sense resistor if long (inductive) battery leads are used.

bq24100, bq24103, bq24105 bq24108, bq24113, bq24115

SLUS606B – JUNE 2004 – REVISED NOVEMBER 2004

- Place all small signal components (C_{TTC} , RSET1/2 and TS) close to their respective IC pin (do not place components such that routing interrupts power stage currents). All small *control* signals should be routed away from the high current paths.
- The PWB should have a ground plane (return) connected directly to the return of all components through vias (3 vias per capacitor for power-stage capacitors, 3 vias for the IC PGND, 1 via per capacitor for small signal components). A *star* ground design approach is typically used to keep circuit block currents isolated (high-power/low-small signal) which reduces noise coupling and ground bounce issues. A single ground plane for this design gives good results. With this small layout and a single ground plane, there is not a ground bounce issue, and having the components segregated minimizes coupling between signals.
- The high-current charge paths into IN and from the OUT pins must be sized appropriately for the maximum charge current in order to avoid voltage drops in these traces. The PGND pins should be connected to the ground plane to return current through the internal low-side FET. The *thermal* vias in the IC PowerPAD™ provide the return path connection.
- The bqSWITCHER is packaged in a thermally enhanced MLP package. The package includes a thermal pad to provide an effective thermal contact between the IC and the printed circuit board (PCB). Full PCB design guidelines for this package are provided in the application note entitled: *QFN/SON PCB Attachment Application Note* (SLUA271). Six 10–13 mil vias are a minimum number of recommended vias, placed in the IC's power pad, connecting it to a ground *thermal* plane on the opposite side of the PWB. This plane must be at the same potential as Vss and PGND of this IC.
- See the User Guide (SLUU200) for an example of good layout.

WAVEFORMS: All waveforms are taken at Lout (IC Out pin). $V_{IN} = 7.6$ V and the battery was set to 2.6 V, 3.5 V, and 4.2 V for the three waveforms. When the top switch of the converter is *on*, the waveform is at ~7.5 V, and when *off*, the waveform is near ground. Note that the ringing on the switching edges is small. This is due to a *tight* layout (minimized loop areas), a shielded inductor (closed core), and using a low-inductive scope ground lead (i.e., short with minimum loop) .

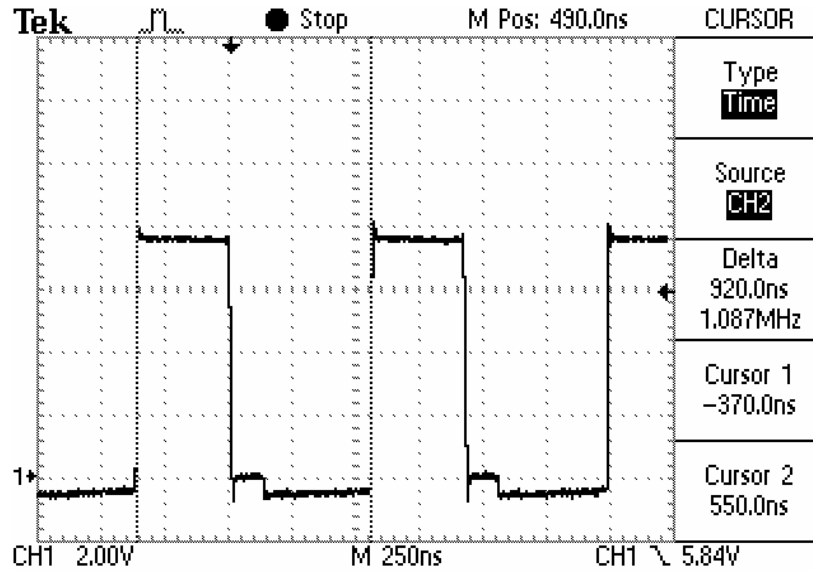

Precharge: The current is low in precharge so the bottom synchronous FET turns off after its minimum on-time which explains the step between ~ 0 V and -0.5 V. When the bottom FET and top FET are off, the current conducts through the body diode of the bottom FET which results in a diode drop below the ground potential. The initial negative spike is the delay turning on the bottom FET, which is to prevent shoot-through current as the top FET is turning off.

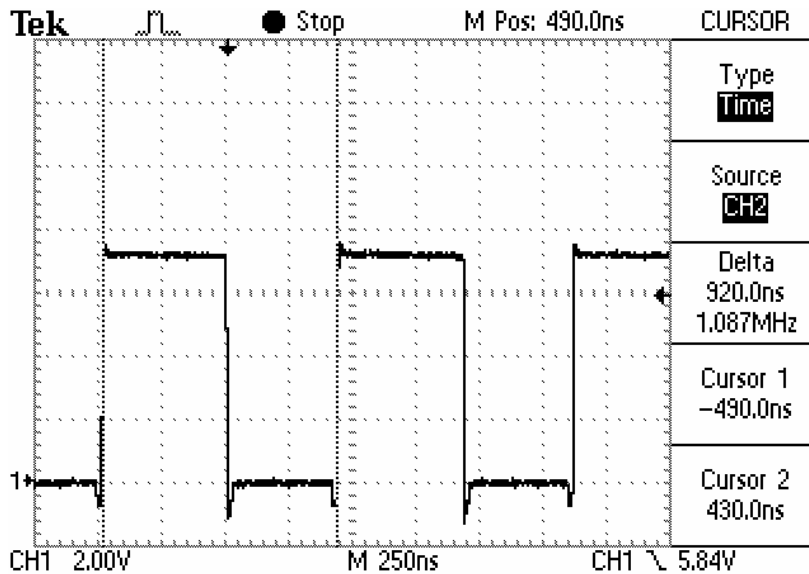

Fast Charge: This is captured during the constant-current phase. The two negative spikes are the result of the short delay when switching between the top and bottom FETs. The break-before-make action prevents current shoot-through and results in a body diode drop below ground potential during the *break* time.

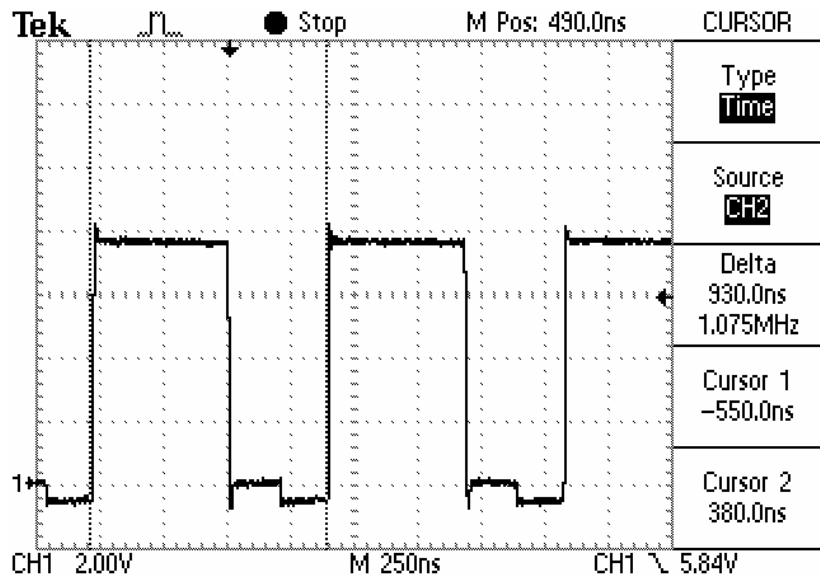

Charge during Voltage Regulation and Approaching Termination: Note that this waveform is similar to the precharge waveform. The difference is that the battery voltage is higher so the duty cycle is slightly higher. The bottom FET stays on longer because there is more of a current load than during precharge; it takes longer for the inductor current to ramp down to the current threshold where the synchronous FET is disabled.

Application Note: Charging Battery and Powering System Without Affecting Battery Charge and Termination.

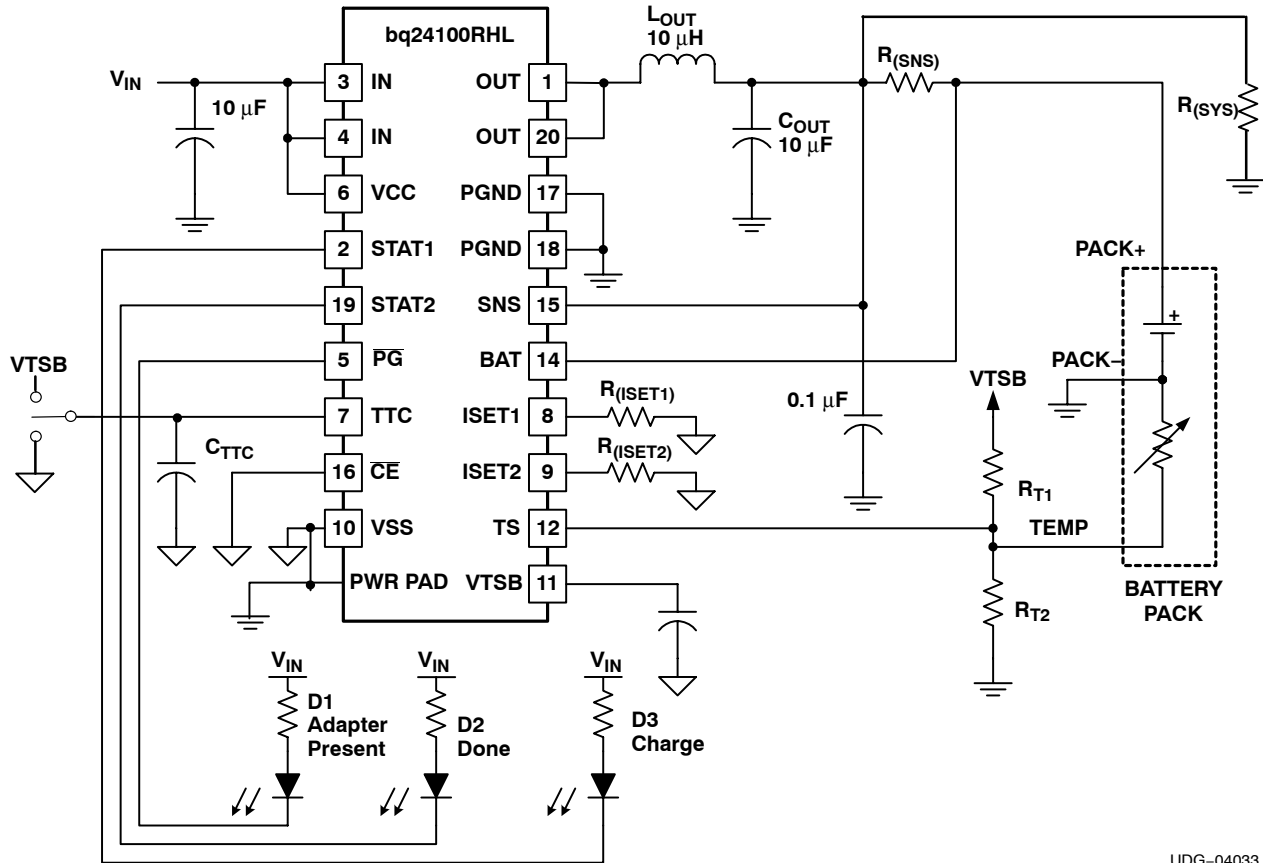

The bqSWITCHER was designed as a stand-alone battery charger but can be easily adapted to power a system load, while considering a few minor issues.

Advantages:

1. The charger controller is based only on what current goes through the current-sense resistor (so precharge, constant current, and termination all work well), and is not affected by the system load.
2. The input voltage has been converted to a usable system voltage with good efficiency from the input.
3. Extra external FETs are not needed to switch power source to the battery.
4. The TTC pin can be grounded to disable termination and keep the converter running and the battery fully charged, or let the switcher terminate when the battery is full and then run off of the battery via the sense resistor.

Other Issues:

1. If the system load current is large (≥ 1 A) the IR drop across the battery impedance causes the battery voltage to drop below the refresh threshold and start a new charge. The charger would then terminate due to low charge current. Therefore, the charger would cycle between charging and termination. If the load is smaller, the battery would have to discharge down to the refresh threshold resulting in a much slower cycling. Note that grounding the TTC pin keeps the converter on continuously.
2. If TTC is grounded, the battery is kept at 4.2 V (not much different than leaving a fully charged battery set unloaded).
3. The efficiency takes a 2–3% hit when discharging through the sense resistor to the system.

THERMAL INFORMATION

This package incorporates an exposed thermal pad that is designed to be attached directly to an external heatsink. The thermal pad must be soldered directly to the printed circuit board (PCB), the PCB can be used as a heatsink. In addition, through the use of thermal vias, the thermal pad can be attached directly to a ground plane or special heatsink structure designed into the PCB. This design optimizes the heat transfer from the integrated circuit (IC).

For information on the Quad Flatpack No-Lead (QFN) package and its advantages, refer to Application Report, Quad Flatpack No-Lead Logic Packages, Texas Instruments Literature No. SCBA017. This document is available at www.ti.com.

The exposed thermal pad dimensions for this package are shown in the following illustration.

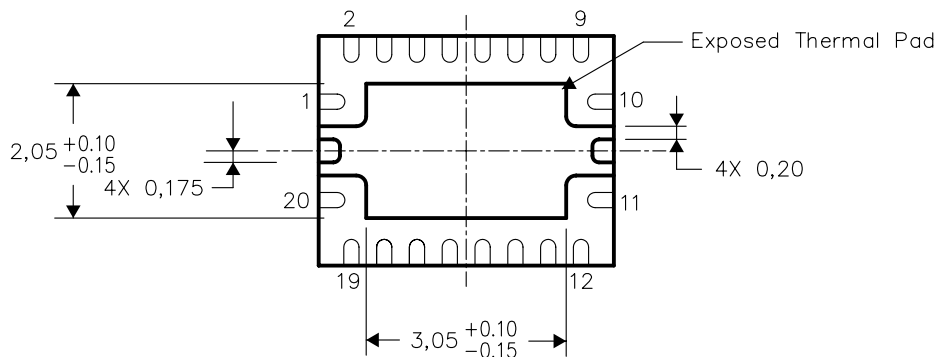

Bottom View

NOTE: All linear dimensions are in millimeters

Exposed Thermal Pad Dimensions

PACKAGING INFORMATION

Orderable Device	Status ⁽¹⁾	Package Type	Package Drawing	Pins	Package Qty	Eco Plan ⁽²⁾	Lead/Ball Finish	MSL Peak Temp ⁽³⁾
BQ24100RHL	PREVIEW	QFN	RHL	20	50	TBD	Call TI	Call TI
BQ24100RHLR	ACTIVE	QFN	RHL	20	3000	Pb-Free (RoHS)	CU NIPDAU	Level-1-260C-UNLIM
BQ24103RHLR	ACTIVE	QFN	RHL	20	3000	Pb-Free (RoHS)	CU NIPDAU	Level-1-260C-UNLIM
BQ24105RHLR	ACTIVE	QFN	RHL	20	3000	Pb-Free (RoHS)	CU NIPDAU	Level-1-260C-UNLIM
BQ24108RHLR	ACTIVE	QFN	RHL	20	3000	Pb-Free (RoHS)	CU NIPDAU	Level-1-260C-UNLIM
BQ24113RHLR	ACTIVE	QFN	RHL	20	3000	Pb-Free (RoHS)	CU NIPDAU	Level-1-260C-UNLIM
BQ24115RHLR	ACTIVE	QFN	RHL	20	3000	Pb-Free (RoHS)	CU NIPDAU	Level-1-260C-UNLIM

⁽¹⁾ The marketing status values are defined as follows:

ACTIVE: Product device recommended for new designs.

LIFEBUY: TI has announced that the device will be discontinued, and a lifetime-buy period is in effect.

NRND: Not recommended for new designs. Device is in production to support existing customers, but TI does not recommend using this part in a new design.

PREVIEW: Device has been announced but is not in production. Samples may or may not be available.

OBSOLETE: TI has discontinued the production of the device.

⁽²⁾ Eco Plan - The planned eco-friendly classification: Pb-Free (RoHS) or Green (RoHS & no Sb/Br) - please check <http://www.ti.com/productcontent> for the latest availability information and additional product content details.

TBD: The Pb-Free/Green conversion plan has not been defined.

Pb-Free (RoHS): TI's terms "Lead-Free" or "Pb-Free" mean semiconductor products that are compatible with the current RoHS requirements for all 6 substances, including the requirement that lead not exceed 0.1% by weight in homogeneous materials. Where designed to be soldered at high temperatures, TI Pb-Free products are suitable for use in specified lead-free processes.

Green (RoHS & no Sb/Br): TI defines "Green" to mean Pb-Free (RoHS compatible), and free of Bromine (Br) and Antimony (Sb) based flame retardants (Br or Sb do not exceed 0.1% by weight in homogeneous material)

⁽³⁾ MSL, Peak Temp. -- The Moisture Sensitivity Level rating according to the JEDEC industry standard classifications, and peak solder temperature.

Important Information and Disclaimer:The information provided on this page represents TI's knowledge and belief as of the date that it is provided. TI bases its knowledge and belief on information provided by third parties, and makes no representation or warranty as to the accuracy of such information. Efforts are underway to better integrate information from third parties. TI has taken and continues to take reasonable steps to provide representative and accurate information but may not have conducted destructive testing or chemical analysis on incoming materials and chemicals. TI and TI suppliers consider certain information to be proprietary, and thus CAS numbers and other limited information may not be available for release.

In no event shall TI's liability arising out of such information exceed the total purchase price of the TI part(s) at issue in this document sold by TI to Customer on an annual basis.

RHL (R-PQFP-N20)

PLASTIC QUAD FLATPACK

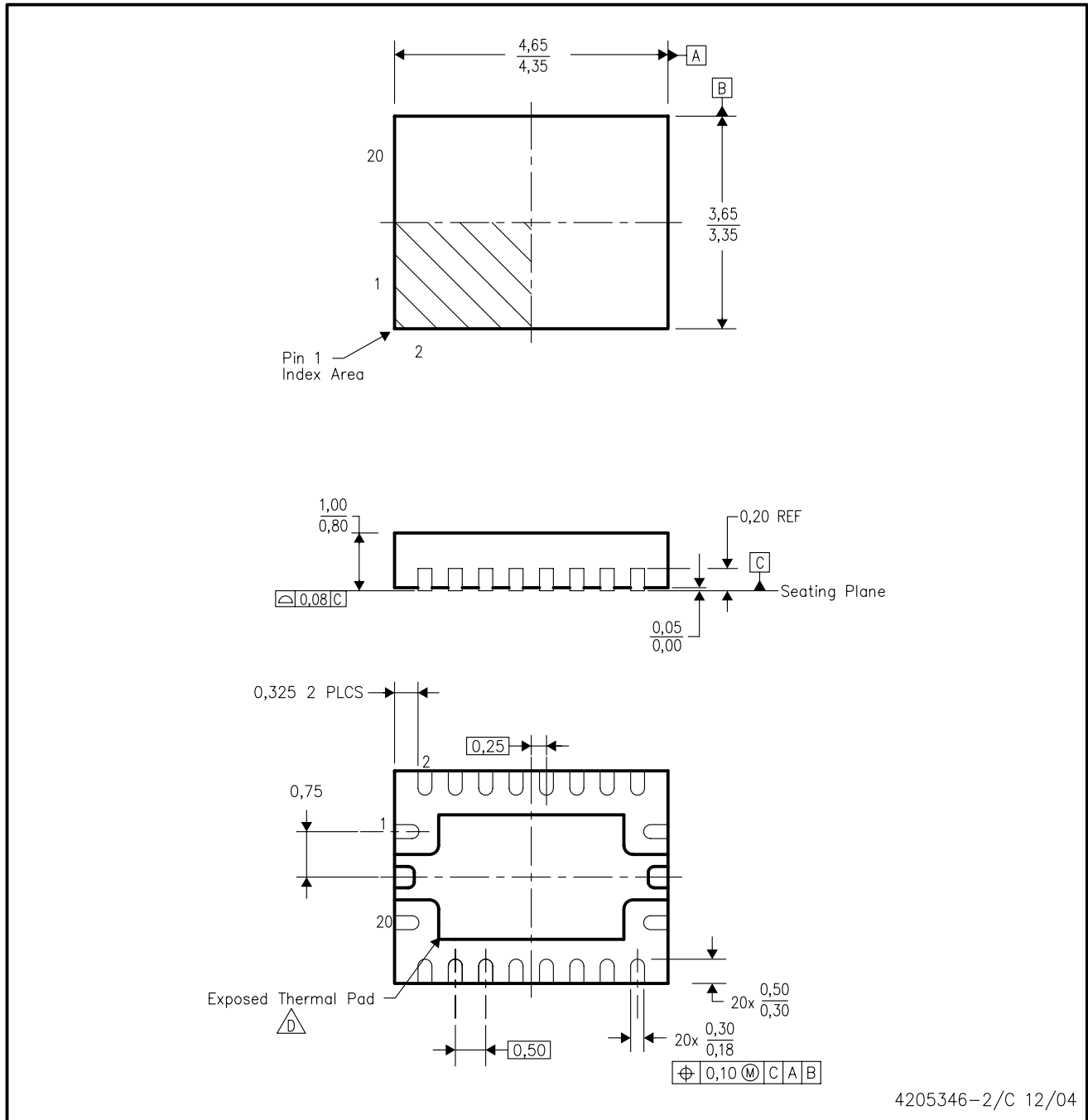

- NOTES:
- A. All linear dimensions are in millimeters. Dimensioning and tolerancing per ASME Y14.5M-1994.
 - B. This drawing is subject to change without notice.
 - C. QFN (Quad Flatpack No-Lead) Package configuration.
 - D. The package thermal pad must be soldered to the board for thermal and mechanical performance. See the Product Data Sheet for details regarding the exposed thermal pad dimensions.

IMPORTANT NOTICE

Texas Instruments Incorporated and its subsidiaries (TI) reserve the right to make corrections, modifications, enhancements, improvements, and other changes to its products and services at any time and to discontinue any product or service without notice. Customers should obtain the latest relevant information before placing orders and should verify that such information is current and complete. All products are sold subject to TI's terms and conditions of sale supplied at the time of order acknowledgment.

TI warrants performance of its hardware products to the specifications applicable at the time of sale in accordance with TI's standard warranty. Testing and other quality control techniques are used to the extent TI deems necessary to support this warranty. Except where mandated by government requirements, testing of all parameters of each product is not necessarily performed.

TI assumes no liability for applications assistance or customer product design. Customers are responsible for their products and applications using TI components. To minimize the risks associated with customer products and applications, customers should provide adequate design and operating safeguards.

TI does not warrant or represent that any license, either express or implied, is granted under any TI patent right, copyright, mask work right, or other TI intellectual property right relating to any combination, machine, or process in which TI products or services are used. Information published by TI regarding third-party products or services does not constitute a license from TI to use such products or services or a warranty or endorsement thereof. Use of such information may require a license from a third party under the patents or other intellectual property of the third party, or a license from TI under the patents or other intellectual property of TI.

Reproduction of information in TI data books or data sheets is permissible only if reproduction is without alteration and is accompanied by all associated warranties, conditions, limitations, and notices. Reproduction of this information with alteration is an unfair and deceptive business practice. TI is not responsible or liable for such altered documentation.

Resale of TI products or services with statements different from or beyond the parameters stated by TI for that product or service voids all express and any implied warranties for the associated TI product or service and is an unfair and deceptive business practice. TI is not responsible or liable for any such statements.

Following are URLs where you can obtain information on other Texas Instruments products and application solutions:

Products		Applications	
Amplifiers	amplifier.ti.com	Audio	www.ti.com/audio
Data Converters	dataconverter.ti.com	Automotive	www.ti.com/automotive
DSP	dsp.ti.com	Broadband	www.ti.com/broadband
Interface	interface.ti.com	Digital Control	www.ti.com/digitalcontrol
Logic	logic.ti.com	Military	www.ti.com/military
Power Mgmt	power.ti.com	Optical Networking	www.ti.com/opticalnetwork
Microcontrollers	microcontroller.ti.com	Security	www.ti.com/security
		Telephony	www.ti.com/telephony
		Video & Imaging	www.ti.com/video
		Wireless	www.ti.com/wireless

Mailing Address: Texas Instruments
Post Office Box 655303 Dallas, Texas 75265