

REV.	ECN NO.	REVISIONS	DRN.	CKD.	APP.	DATE
A		NEW RELEASE	ADM	D.C.	N.O.	5/15/01
B	01052401	Ø .080 WAS Ø .079, DIM .110 WAS .120, .855 WAS 1.100, Ø .086 WAS Ø .079; ADDED: TOL ± .003 TO .228 DIM; NOTE 5	ADM			

* DENOTES CRITICAL DIMENSION OR SPECIFICATION.

NOTES:

1. COMPONENT TO BE MOLDED IN A CLEAR TRANSMISSIVE POLYCARBONATE.
2. COMPONENT DESIGNED TO BE PRESSED INTO A P.C. BOARD.
3. LIGHTSOURCE: RED/GREEN SMT BI-COLOR LED; DIALIGHT P/N: 597-77X1-5XX & YELLOW SMT SINGLE; 597-3XX1-5XX.
4. DIALIGHT PART NUMBER: 515-1118.
5. LIGHTPIPE USED WITH SFP CAGE ASSEMBLY. ASSEMBLY MEETS SMALL FORM-FACTOR PLUGGABLE (SFP) TRANSCEIVER MULTISOURCE AGREEMENT (MSA).

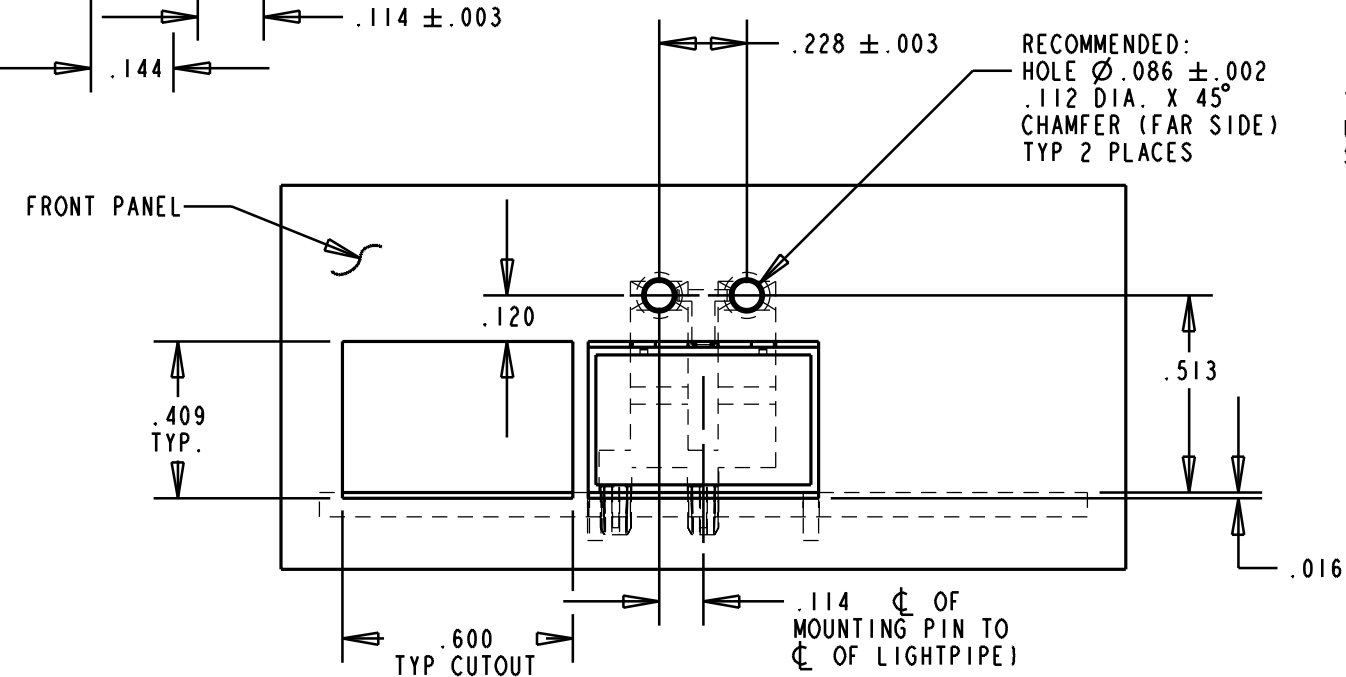
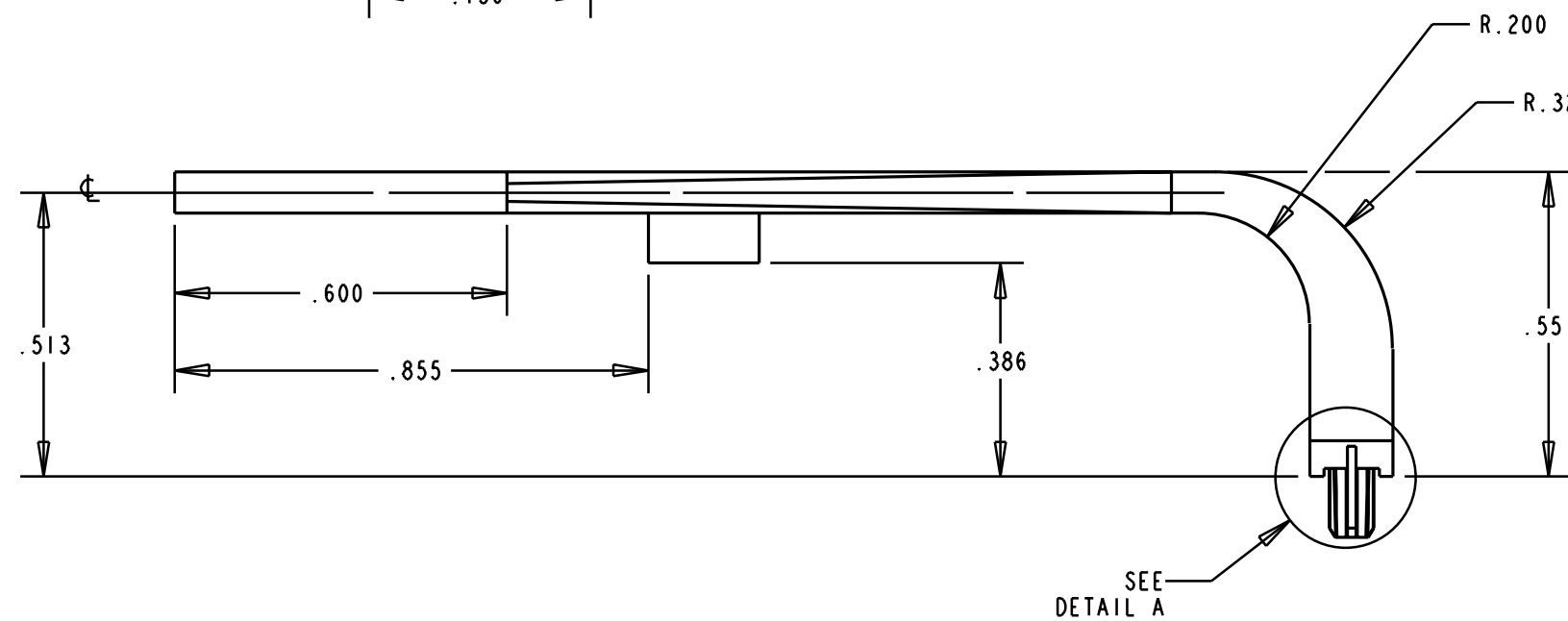
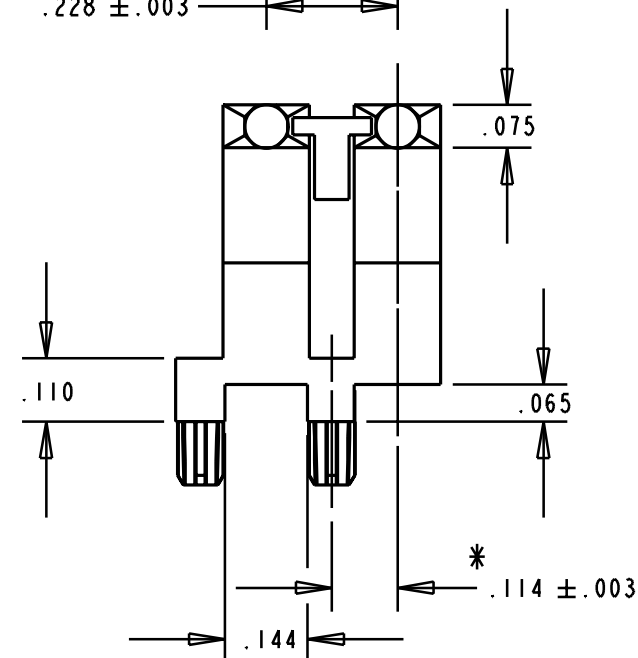
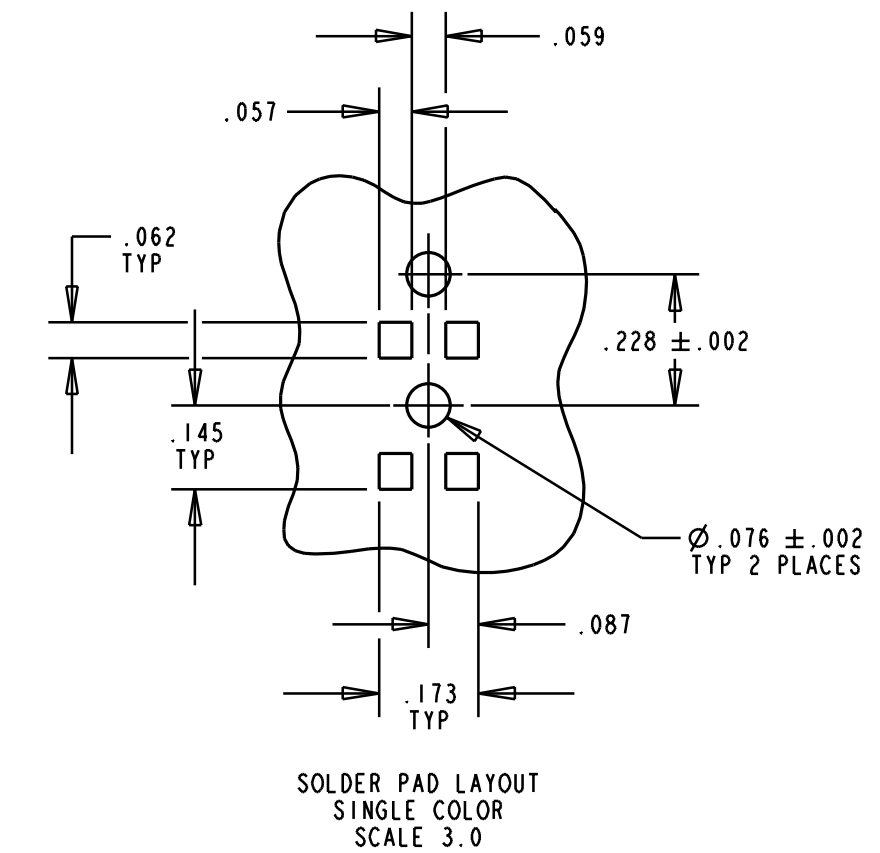
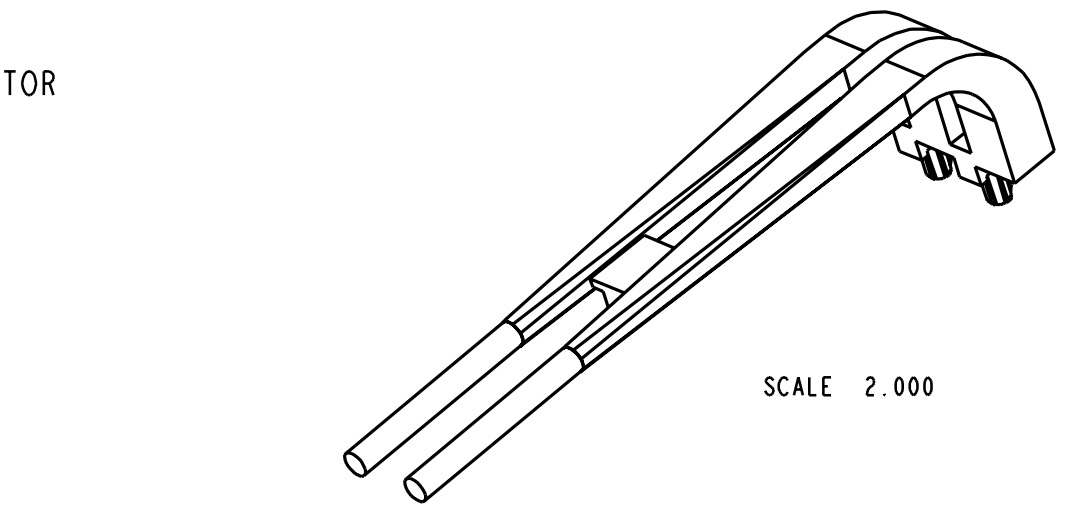
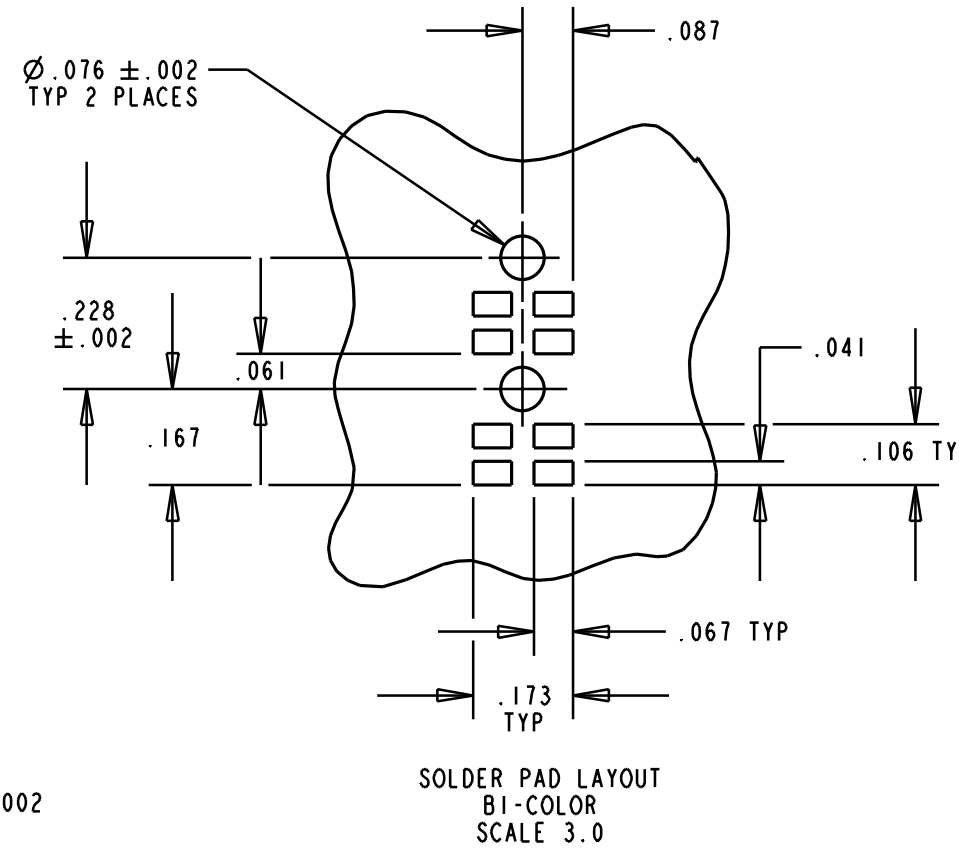
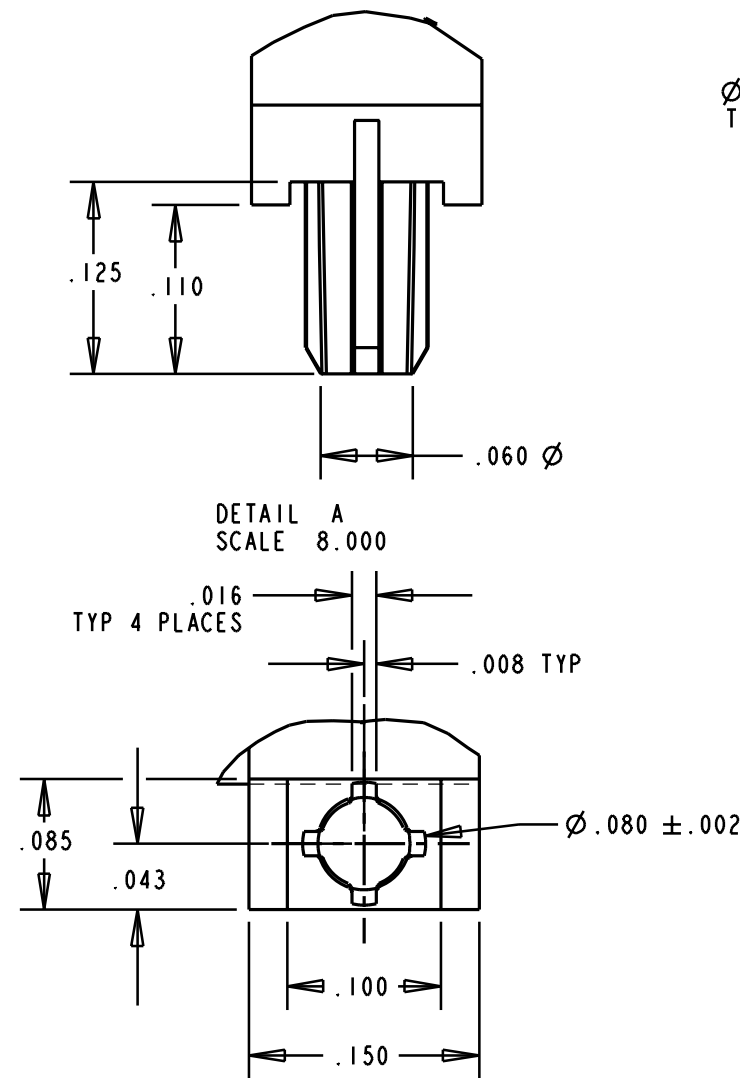
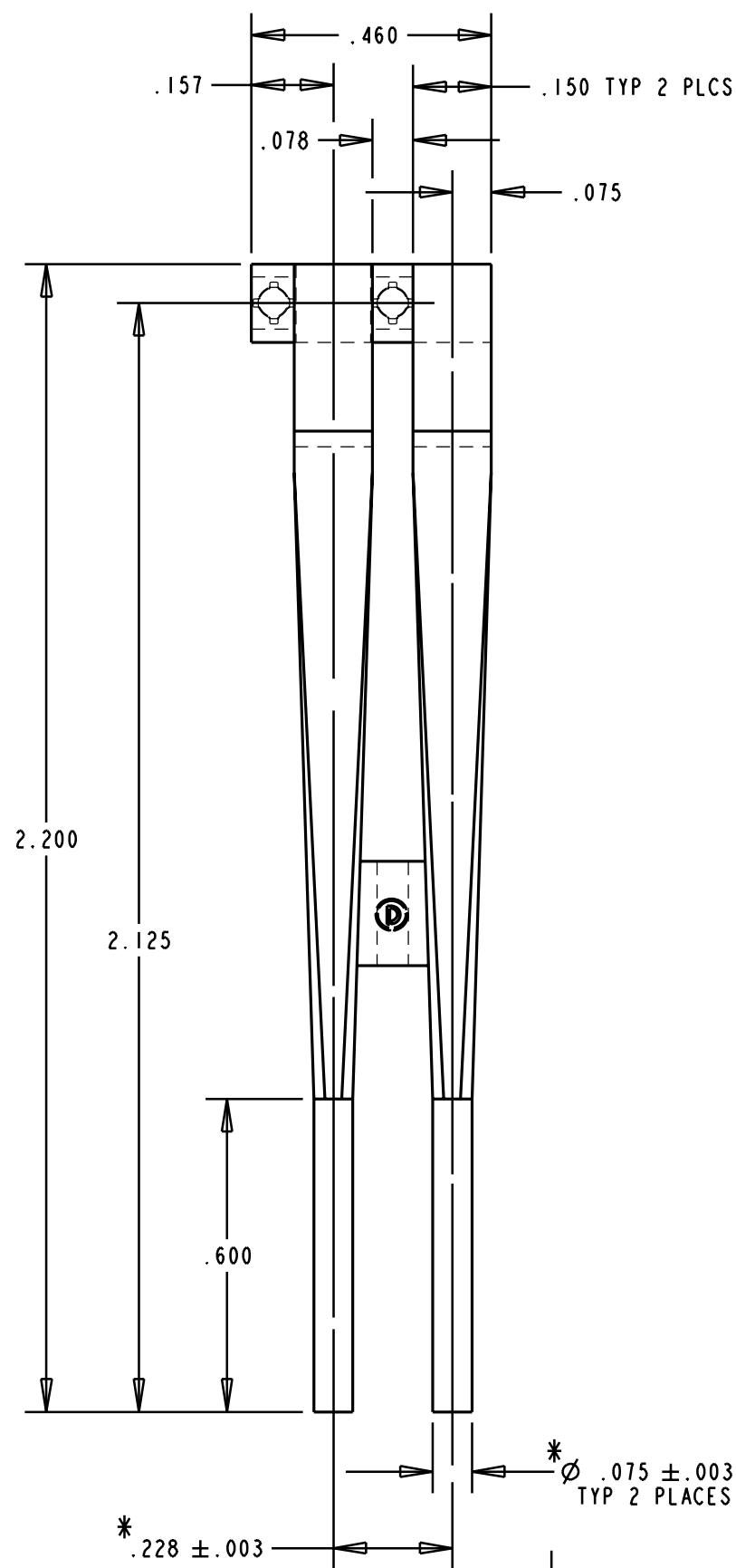

TYPICAL LIGHTPIPE APPLICATION USED WITH (SFP) CAGE ASSEMBLY SCALE 2.000

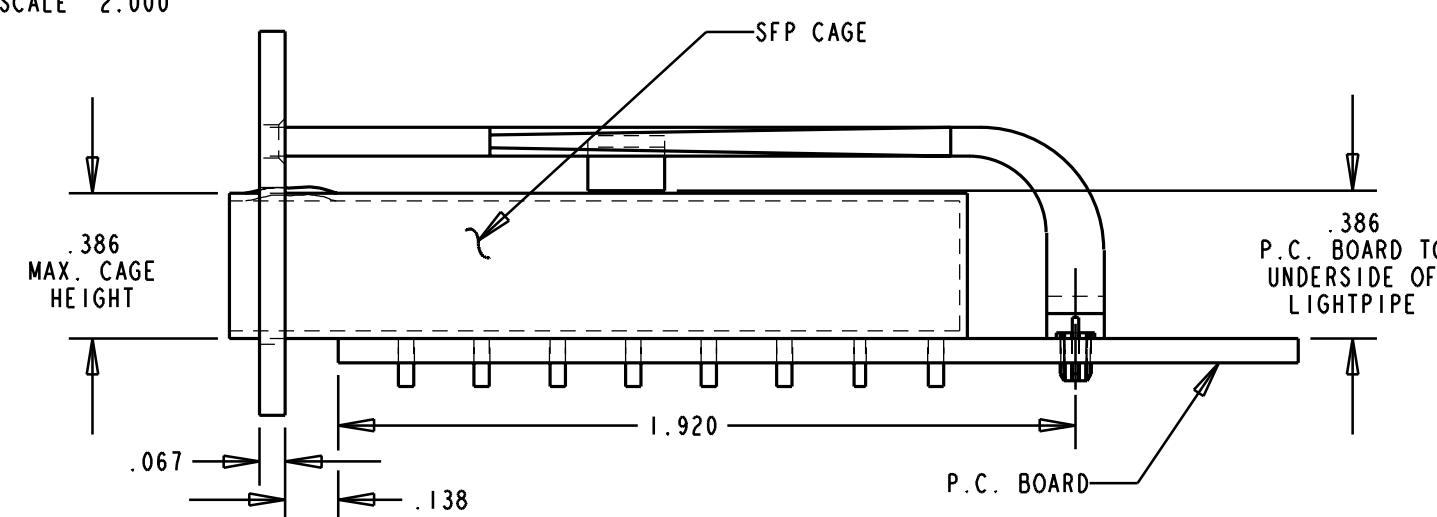

THIS DRAWING AND THE CONTENTS HEREIN ARE CONFIDENTIAL AND THE SOLE PROPERTY OF DIALIGHT. REPRODUCTION OF THIS DRAWING OR CONSTRUCTION OF ANY PARTS WITHIN THIS DRAWING ARE FORBIDDEN WITHOUT THE WRITTEN CONSENT OF DIALIGHT.

SCALE 3:0	DRAWING NUMBER	REV
ALL DIM'S IN: INCHES	C-16815	B
TOLERANCES: UNLESS OTHERWISE SPECIFIED	TITLE	
FRACTIONS: ±1/64	2 ELEMENT LIGHTPIPE	
DECIMALS (.XX): ±.01	MATERIAL	SEE NOTE 1
DECIMALS (.XXX): ±.005		
DECIMALS (.XXXX): ±.0005		
ANGLES: ±1°		
FINISH:	Dialight	1501 ROUTE 34 SOUTH FARMINGDALE, NJ 07727
FSCM 83330	SHEET OF	FAMILY TABLES: