

MECHETRONICS LIMITED
At the Forefront of Solenoid Technology

Laminated Solenoid Series TT2, TT4, TT6 and TT10

This range of a.c. solenoids was originally designed as a low cost item to meet the mass production orders of the domestic appliance industry, where they have met with considerable success. Four solenoids comprise the range and all feature three-point seating and efficient shading rings for quiet operation. The life expectancy of the solenoid is of the order of 100,000 operations.

Efficient operation and optimum performance of a solenoid depends upon its basic design and construction. The development of the TT plunger design has considerably improved the performance of solenoids. This design has materially overcome the deficiencies of the T and I type solenoids.

DOUBLE T SOLENOIDS PERFORM MORE WORK

The TT plunger construction permits the use of a large air gap between the plunger stem and the extremities of the frame legs resulting in virtually level pull characteristics throughout the useful plunger stroke. As the plunger stroke decreases, the extra T section on the double T plunger bridges the gap in the frame. This bridging effect provides additional pull at the point preventing a drop in power, which occurs, on I and T type solenoids as illustrated in the diagram.

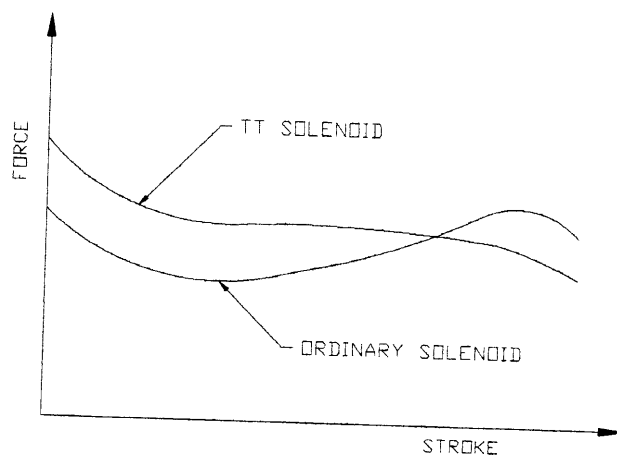

THREE POINT SEATING SURFACE FOR QUIET SOLENOID OPERATION

Coining three bars on the seating surface of the plunger ... one bar on the side of the plunger axis and two bars on the other side produces the three-point seating. Since three points determine a plane, these three bars provide firm seating of the plunger, greatly reducing the possibilities of solenoid noise due to irregularities in the opposing surface. This feature also increases the quiet seat pull.

OUTSTANDING FEATURES

- **SHADING RINGS** – location and design ensure maximum effectiveness in providing quiet seat pull. Rings are locked into the frame assembly.
- **MOISTURE RESISTANT COIL** – the winding wire is 155°C rated and the coil is varnish impregnated and sealed.
- **PROTECTION AGAINST ENVIRONMENTAL CONDITIONS** – provided by Zinc plating and chromate passivation.
- **STURDY ONE-PIECE BOBBIN CONSTRUCTION** – simple design in glass reinforced nylon.
- **STRICT QUALITY CONTROL** – maintained through all fabrication and assembly operations.

MECHETRONICS LIMITED
At the Forefront of Solenoid Technology

SOLENOID SELECTION

Never select an overrated solenoid, which will develop much more force than is required by the load, unless speed of operation is the determining factor. Excessive energy imparted to the solenoid plunger must be dissipated by some means; otherwise the plunger and field piece will absorb the energy on impact, causing premature failure. As coil temperature increases, pull decreases. The amount depends upon the particular application, duty cycle and environment, and it is difficult to anticipate all situations. However, a widely used rule of thumb is to select a solenoid which will deliver a slightly greater force at 120°C (total coil temperature) than the load requires for the lowest anticipated voltage. (See Figure A)

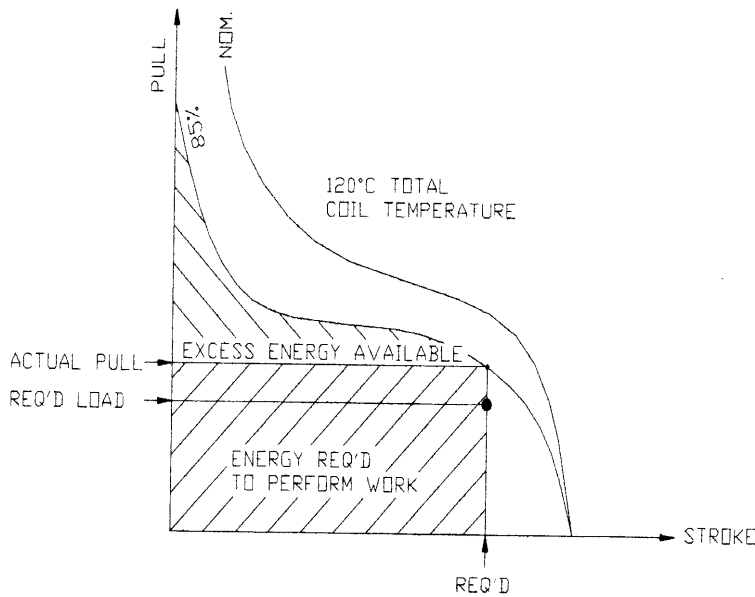

FIG. A.
TYPICAL AC SOLENOID
PULL-STROKE CURVE
STATIC LOAD APPLICATION

DUTY CYCLE

Duty cycle, expressed in percent, is the ratio of time on over the total time as calculated for any cycle of operation. Continuous duty is a 100% duty cycle. Intermittent duty is less than 100% duty cycle. One cycle of operation is the time from the beginning of a cycle to the beginning of the next exact duplicate cycle of operation. In calculating intermittent duty cycle, it is important to calculate on repetitive cycles of operation. For example: if the solenoid is energised for one minute and de-energised for three minutes, the duty cycle is as follows

$$\begin{aligned} \text{Duty cycle in \%} &= \frac{\text{on time}}{\text{on time} + \text{off time}} \times 100\% \\ &= \frac{1}{1 + 3} \times 100\% = 25\% \end{aligned}$$

The majority of intermittent duty cycles will fall in one of two categories: 25%, and 5% duty cycle.

OPERATING TEMPERATURE

Two aspects of temperature require consideration in selecting a solenoid: Ambient temperature and the temperature rise in the solenoid.

MECHETRONICS LIMITED

At the Forefront of Solenoid Technology

Ambient temperature is the temperature of the area in which the solenoid is to operate and can be assumed to be the temperature of the solenoid before any electrical operation.

Operation of the solenoid causes a great rise in temperature, and the greater the power input the greater the temperature rise. This can be seen from this representative thermal characteristic curve.

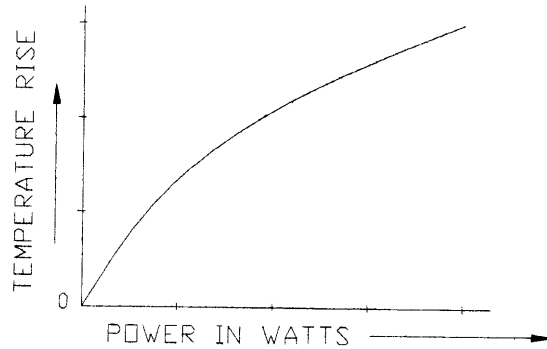

SOLENOID SELECTION

The above curve shows that the relation between power input and temperature rise. For any power applied continuously, the temperature of the solenoid will rise a specific amount and maintain that temperature.

Temperature rise of any solenoid may be calculated as follows:

$$t_1 = \left(\frac{R_t - R_{t1}}{R_{t1}} \right) (234.5 + t)$$

R_{t1} = resistance at start of test (Ω)

R_t = resistance at end of test (Ω)

t = ambient temperature in $^{\circ}\text{C}$

The temperature rating of the insulating materials determines the maximum operating temperature of any solenoid. As long as this maximum temperature is not exceeded, the solenoid pull characteristics will not be degraded. Standard Mechetronics solenoids use Class E insulation; therefore the maximum temperature should not exceed 120°C . Other classes of insulation are available for most solenoids. To aid selection, the following definitions are included:

Insulation Classification by Temperature Limits

Class A – 110°C maximum Class F – 155°C maximum

Class E – 120°C maximum Class H – 180°C maximum

Class B – 130°C maximum Class C – 220°C and above

MAXIMUM ON TIME

The temperature rise of any solenoid must be limited so that it does not rise to a point at which the material of the solenoid begins to be adversely affected. This limitation of maximum on time for different insulations is illustrated here.

As can be seen from the curves, the higher the power input the higher temperature insulation must be used, or the on-time reduced.

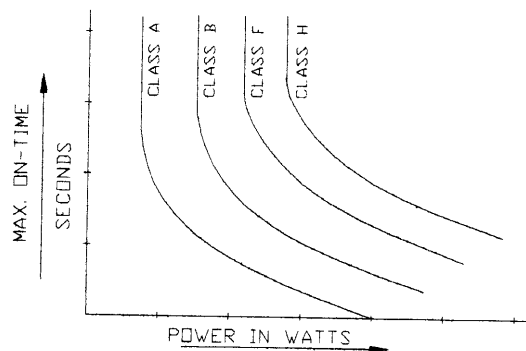

CONTINUOUS DUTY solenoids may remain permanently energized at rated voltage under load without exceeding the maximum temperature rise of 80°C over ambient. A continuous duty DC solenoid may be subject to continuous "on-off" cycling without over-heating.

MECHETRONICS LIMITED

At the Forefront of Solenoid Technology

With AC solenoids an inrush current occurs until the plunger is seated. The longer the stroke, the higher the inrush current. In continuous duty AC solenoids which are subject to "on-off" cycling, repetitious surges could cause the coil to overheat and result in temperature rise greater than 80°C. A reduction in duty cycle is necessary under these conditions.

INTERMITTENT DUTY solenoids are designed to be energized for a maximum period of time without exceeding 80°C heat rise above ambient. At the end of maximum on time, it must be permitted to cool before resuming operation.

HOW TO INCREASE SOLENOID LIFE EXPECTANCY

LOAD APPLICATION

Proper alignment of plunger and load is very important. Loading which is not directly centered along the line of plunger travel should be avoided. If misalignment occurs, plunger wear will increase and with AC solenoids, seating will be impaired.

Where an AC laminated plunger is directly linked to a mechanical load and the probability of jamming is high, coil burnout protection should be incorporated. Two techniques are suggested. The first involves inclusion of a Thermal cut-out device in the coil winding. The second incorporates a tension spring between plunger and load, see diagram opposite. The initial tension of the spring must be more than the force of the load and it must be designed so that if the load jams, the plunger will seat in spite of the overload. (See Figure B)

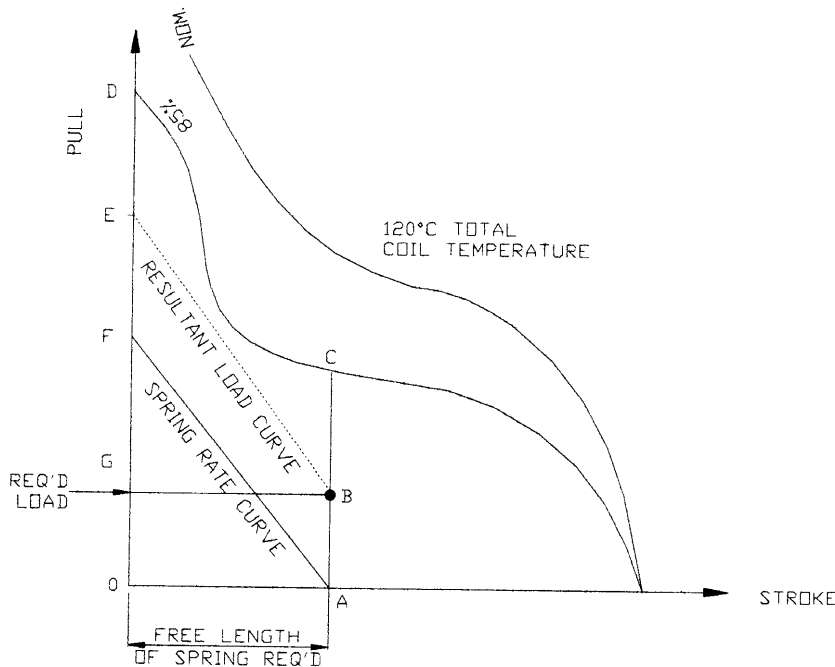
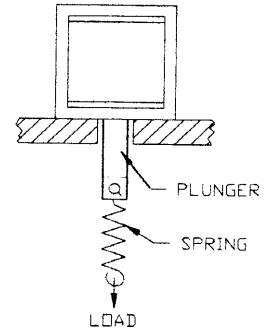

FIG. B.
 TYPICAL AC SOLENOID
 PULL-STROKE CURVE
 SPRING + STATIC
 LOAD APPLICATION

- AREA O-A-C-D-O = TOTAL SOLENOID ENERGY AVAILABLE AT SPECIFIED STROKE
- AREA O-A-B-G-O = ENERGY REQUIRED TO PULL STATIC LOAD ALONE
- AREA O-A-F-O = ENERGY REQUIRED TO DEFLECT SPRING ALONE
- AREA O-A-B-E-O = ENERGY REQUIRED TO DO REQUIRED WORK ON STATIC LOAD AND SPRING
- AREA B-C-D-E-B = EXCESS ENERGY DEVELOPED BY SOLENOID

MECHETRONICS LIMITED

At the Forefront of Solenoid Technology

LIMIT PLUNGER TRAVEL

By keeping plunger travel to a minimum, the solenoid's deliverable energy will be more efficiently utilized. This will reduce plunger wear and frame fatigue. This will also result in cooler operation of AC solenoids, since inrush current will be less than that of longer strokes.

MINIMUM POWER INPUT

Selection of a solenoid, which most closely matches the mechanical load requirements, is the best approach to improve longevity. Selection of an overrated solenoid or application of excessive electrical energy to a coil leaves available energy present, which must be dissipated in some manner. This can result in plunger pounding and/or excessive heat. In either case solenoid life will be reduced. (See Figures A & B)

MINIMIZE IMPACT

One means of dissipating excess energy is a compression spring (See Figure B). As the plunger travels toward the seated position, the force required to compress the spring continually increases. This provides, in effect, a cushion against impact by dissipating some of the excess energy.

In DC operated solenoids the impact may be minimized and solenoid longevity increased by preventing the plunger from seating against a metallic plug (stop). This technique may be used in those applications where holding force is of no great importance, and some reduction in overall pull can be tolerated.

NOTE: The resultant loading curve (weight of load plus spring rate curve) should never exceed the lowest operating point on the solenoid pull-stroke curve or the plunger will stall at this point (See Figure B).

HUM

An AC solenoid will never be completely silent. However, to minimize hum, an AC plunger must seat firmly. If excessive hum exists, the coil may tend to overheat. Therefore, while proper application, alignment and seating will keep the inherent hum to a minimum, it will increase with wear or with dirt on the plunger in applications where hum would be objectionable, a DC solenoid should be used.

SPEED OF OPERATION

The speed of operation is a function of the applied load, power and stroke. On AC solenoids operating speed will also vary depending on the point of the applied voltage cycle at which the solenoid is energized. If a consistent operating speed is required, a DC solenoid should be selected. A DC solenoid's actuation will be constant if the applied voltage and ambient temperature are maintained.

ELECTRICAL REQUIREMENTS AND POWER LIMITATIONS

MECHETRONICS 50 Hz AC solenoids described in this bulletin are available as standard models with the following voltages: 24, 110 & 240V. Standard DC solenoids are available for 6, 12, & 24V operation. However, quotations and samples can be furnished for other voltages and frequencies.

MECHETRONICS standard AC solenoids are designed for 50Hz operation. If used on 60Hz supply, the solenoid will not develop the rated force.

Regulation of the applied coil voltage must be considered before selecting the solenoid for your particular application. In the case of low voltage solenoids drawing heavy current, be certain the supply is capable of delivering at least the minimum power. Since increasing temperature can cause performance degradation, performance curves are shown with the solenoid HOT and at 90% rated voltage.

MECHETRONICS produce a wide range of Electro-mechanical products - AC & DC Linear types, Fluid Power solenoids, Pneumatics solenoids, Permanent Magnet solenoids, Holding Magnets, Solenoid Locks, Switchgear Trip solenoids and Assemblies.

MECHETRONICS LIMITED is a BSI Quality Assurance assessed company to ISO 9001.

Appendix 2

AC Solenoids Laminated



St Helen Auckland, Bishop Auckland, County Durham DL14 9AA, England
Telephone + 44 (0) 1388 604000 : Facsimile + 44 (0) 1388 607666
Email: sales@mechtronics.co.uk Web Site: www.mechtronics.co.uk

Model TT2 (SD116)

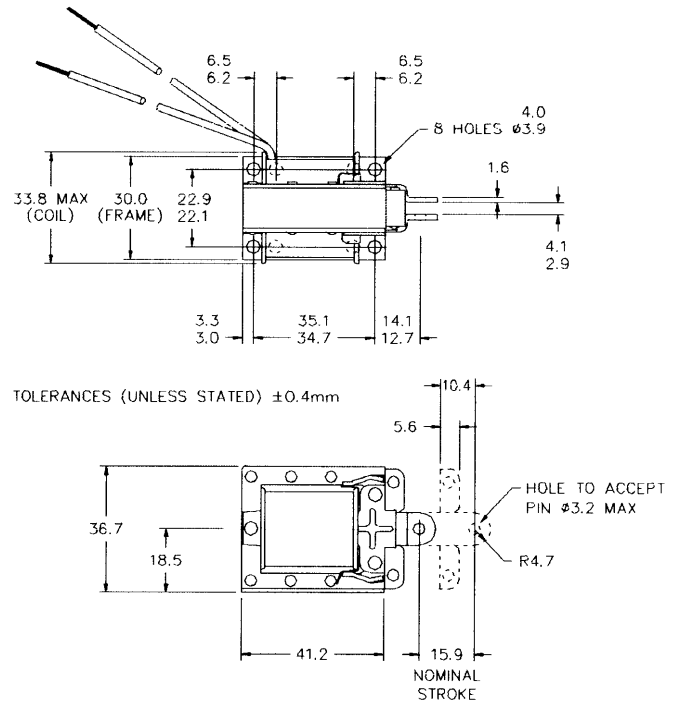
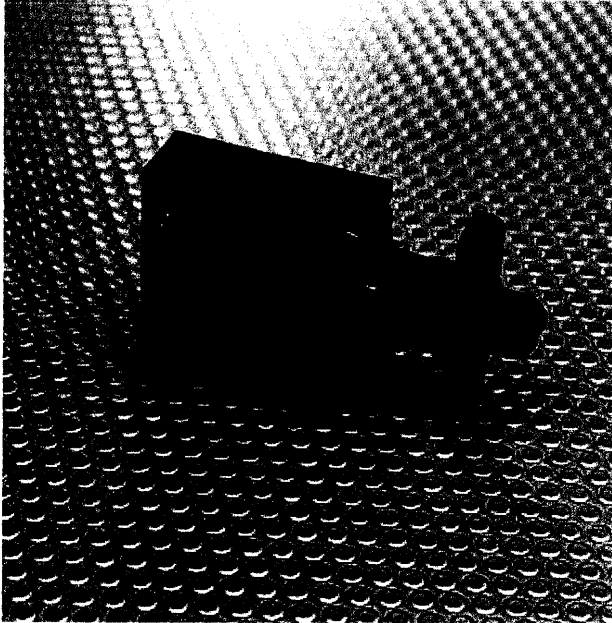

High Force / Small Size

Fast Response Time

Rugged Design for Long Life

Varnish Impregnated Coil

Brass Guides

Copper Shading Rings

Optional Zinc Plated Plunger & Yoke

Various Voltages and Frequencies

Optional Encapsulated Coil

Magnet force-stroke curve for bottom nameplate voltage and solenoid temperature of 90°C.

VA—stroke curve for top nameplate voltage, 20°C ambient.

If plunger works with gravity:

stroke force = magnet force + plunger weight force.

If plunger works against gravity:

stroke force = magnet force - plunger weight force.

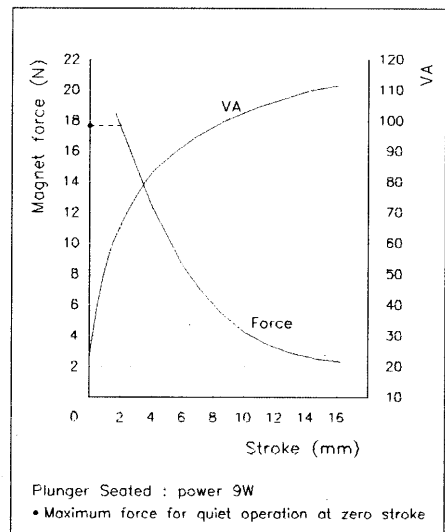

7001

AT THE FOREFRONT OF SOLENOID TECHNOLOGY



Registered in England No 2916339

INVESTOR IN PEOPLE

AC Solenoids Laminated



St Helen Auckland, Bishop Auckland, County Durham DL14 9AA, England
Telephone + 44 (0) 1388 604000 : Facsimile + 44 (0) 1388 607666
Email: sales@mechetronics.co.uk Web Site: www.mechetronics.co.uk

Model TT4 (SD117)

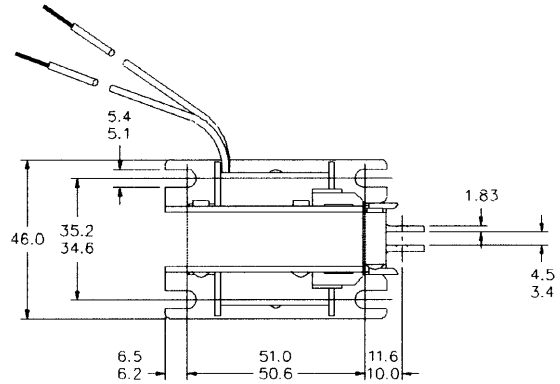
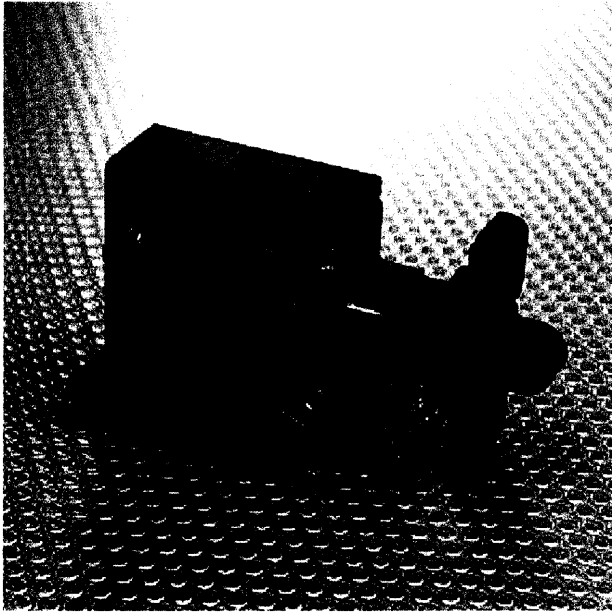

TOLERANCES (UNLESS STATED) ±0.4mm

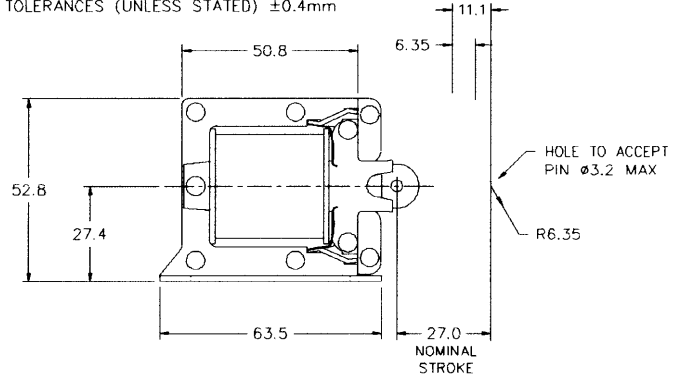

- High Force / Small Size
- Fast Response Time
- Rugged Design for Long Life
- Varnish Impregnated Coil
- Brass Guides
- Copper Shading Rings
- Optional Zinc Plated Plunger & Yoke
- Various Voltages and Frequencies
- Optional Encapsulated Coil

Magnet force-stroke curve for bottom nameplate voltage and solenoid temperature of 90°C.

VA-stroke curve for top nameplate voltage, 20°C ambient.

If plunger works with gravity:
stroke force = magnet force + plunger weight force.

If plunger works against gravity:
stroke force = magnet force - plunger weight force.

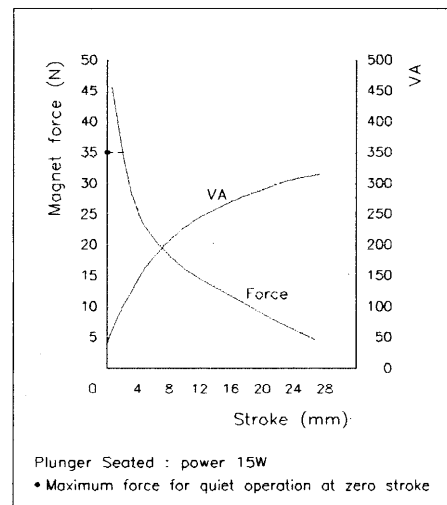

9001

AT THE FOREFRONT OF SOLENOID TECHNOLOGY



Registered in England No 2916339

INVESTOR IN PEOPLE

AC Solenoids Laminated



St Helen Auckland, Bishop Auckland, County Durham DL14 9AA, England
Telephone + 44 (0) 1388 604000 : Facsimile + 44 (0) 1388 607666
Email: sales@mechetronics.co.uk Web Site: www.mechetronics.co.uk

Model TT6 (SD118)

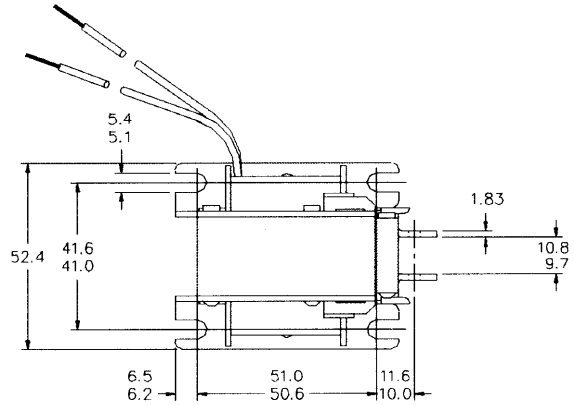
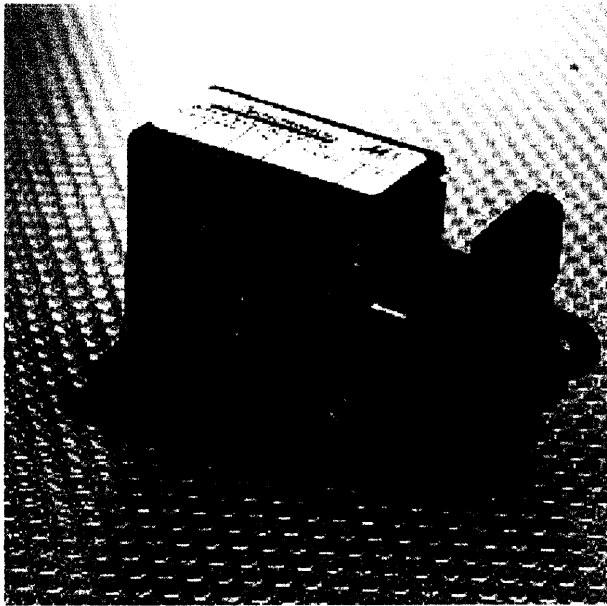

TOLERANCES (UNLESS STATED) $\pm 0.4\text{mm}$

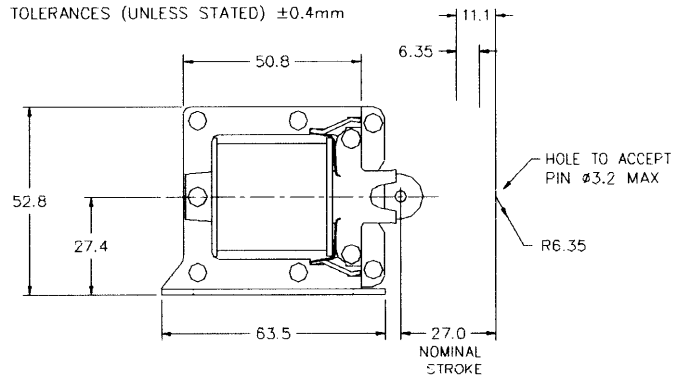

- High Force / Small Size
- Fast Response Time
- Rugged Design for Long Life
- Varnish Impregnated Coil
- Brass Guides
- Copper Shading Rings
- Optional Zinc Plated Plunger & Yoke
- Various Voltages and Frequencies
- Optional Encapsulated Coil

Magnet force-stroke curve for bottom nameplate voltage and solenoid temperature of 90°C.

VA-stroke curve for top nameplate voltage, 20°C ambient.

If plunger works with gravity:
stroke force = magnet force + plunger weight force.

If plunger works against gravity:
stroke force = magnet force - plunger weight force.

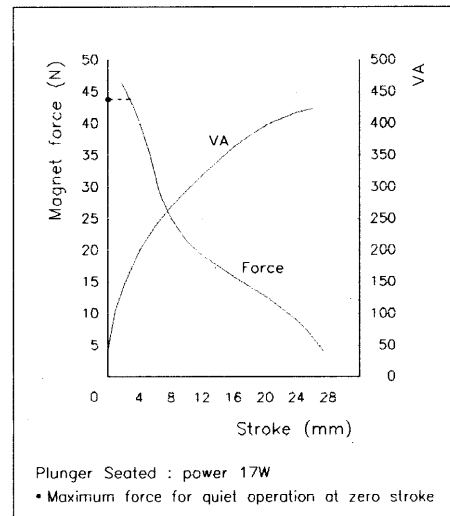

9001

AT THE FOREFRONT OF SOLENOID TECHNOLOGY



Registered in England No 2916339

INVESTOR IN PEOPLE

AC Solenoids Laminated



St Helen Auckland, Bishop Auckland, County Durham DL14 9AA, England
Telephone + 44 (0) 1388 604000 : Facsimile + 44 (0) 1388 607666
Email: sales@mechetronics.co.uk Web Site: www.mechetronics.co.uk

Model TT10 (SD119)

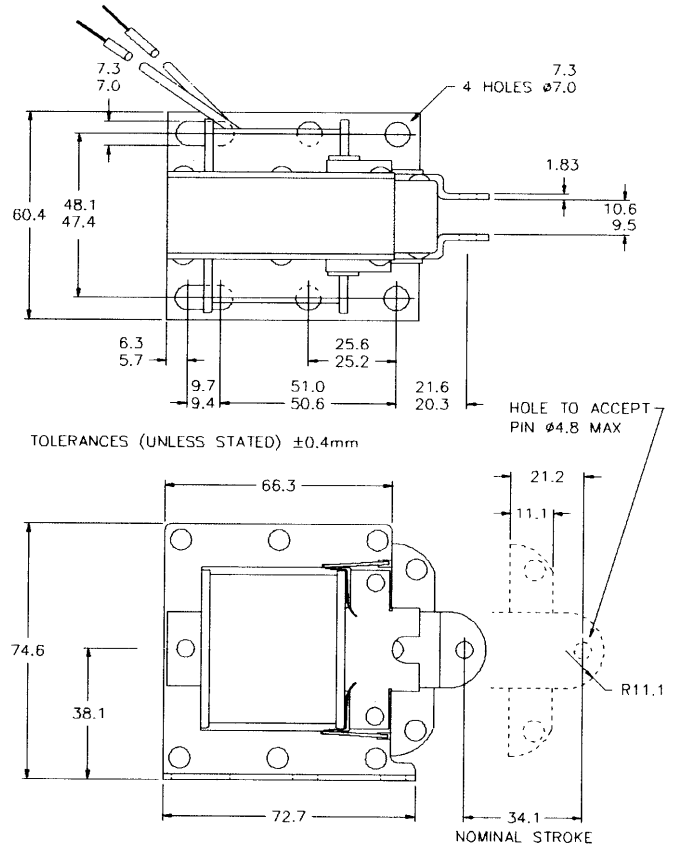
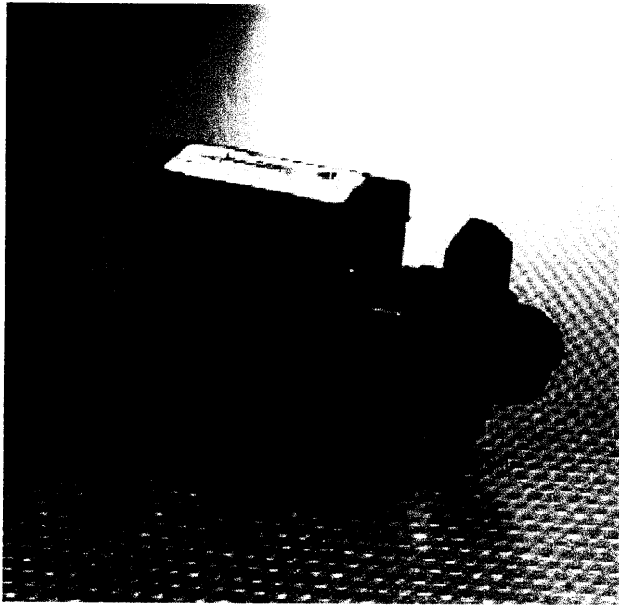

- High Force / Small Size
- Fast Response Time
- Rugged Design for Long Life
- Varnish Impregnated Coil
- Brass Guides
- Copper Shading Rings
- Optional Flying Leads
- Various Voltages and Frequencies
- Optional Encapsulated Coil

Magnet force-stroke curve for bottom nameplate voltage and solenoid temperature of 90°C.

VA-stroke curve for top nameplate voltage, 20°C ambient.

If plunger works with gravity:

stroke force = magnet force + plunger weight force.

If plunger works against gravity:

stroke force = magnet force - plunger weight force.

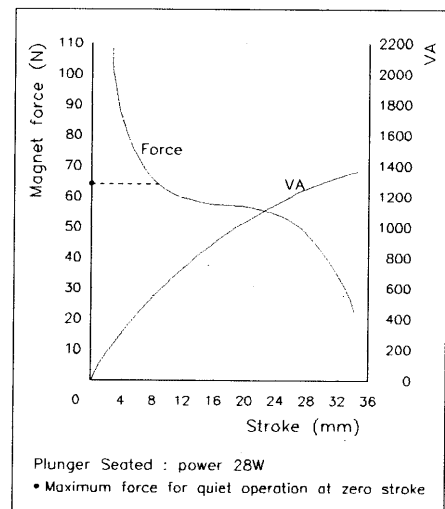

9001

AT THE FOREFRONT OF SOLENOID TECHNOLOGY



Registered in England No 2916339

INVESTOR IN PEOPLE