



FEATURES

- Standard Package and Pin-out
- Single 5V Power Supply
- 12-Bit Resolution
- Optical Isolation
- Intermix With Digital Modules on the Same Rack
- Meets the Requirements of IEEE 472
- UL, CSA, CE Certified (OpenLine® only)

DIMENSIONS

For complete dimensional drawings, see page L-23 to L-24.

CIRCUITRY: Voltage Output

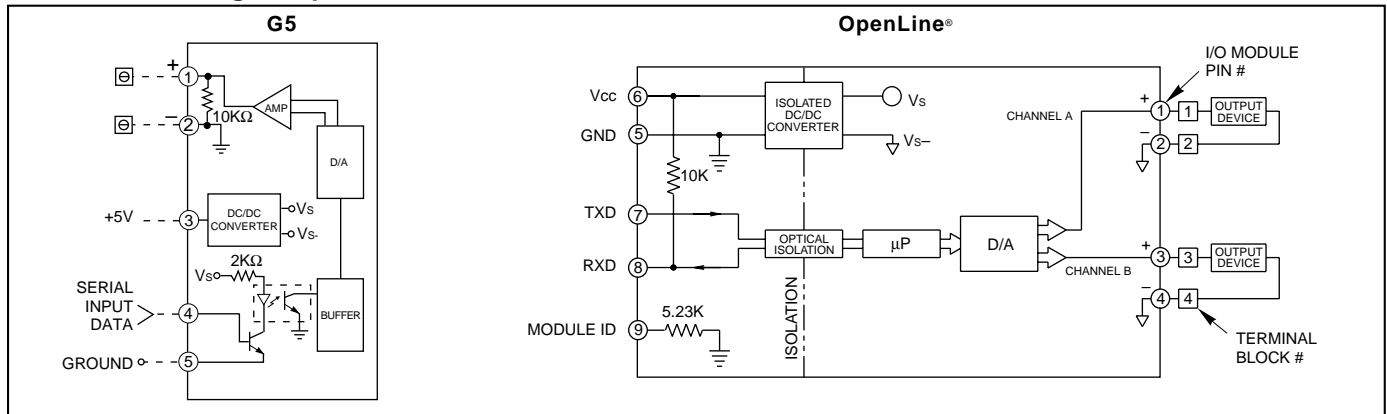

SPECIFICATIONS: By Part Number

Type/Function		Grayhill Part Number			
G5, OpenLine®		73G-OV5, -OV5B	73G-OV10, -OV10B	73L-OV5, -OV5B	73L-OV10, -OV10B
Specifications	Units				
Number of Outputs		1 Ch., Diff.	1 Ch., Diff.	2 Ch., S.E.	2 Ch., S.E.
Resolution	bits	12	12	12	12
	mV/count	-OV5: 1.22 -OV5B: 2.44	-OV10: 2.44 -OV10B: 4.88	-OV5: 1.22 -OV5B: 2.44	-OV10: 2.44 -OV10B: 4.88
Absolute Accuracy @ 25°C ^{1,2}		0.3% of full scale	0.3% of full scale	0.08% of full scale	0.06% of full scale
Accuracy Drift w/Temp. ²					
Maximum Offset	PPM/°C	+/- 45	+/- 45	+/- 25	+/- 25
Maximum Gain (0 to 60°C)	PPM/°C	+/- 150	+/- 150	+/- 100	+/- 100
Serial Data Format		12-bit packet	12-bit packet	Left-justified, 16-bit	Left-justified, 16-bit
Serial Data Packet		—	—	115.2Kb, N, 8, 2	115.2Kb, N, 8, 2
Step Response Time	mS	0.5	0.5	0.8	0.8
Output Noise Ripple	mV rms	—	—	1.5 max.	3.7 max.
Output Voltage Range	Vdc	-OV5: 0-5 -OV5B: -5-5	-OV10: 0-10 -OV10B: -10-10	-OV5: 0-5 -OV5B: -5-5	-OV10: 0-10 -OV10B: -10-10
Maximum Load	Ω	250	1000	250	500
Logic Voltage Range	Vdc	4.5-5.5	4.5-5.5	4.75-5.25	4.75-5.25
Maximum Logic Supply Current @ 5Vdc	mA/Ch.	140	140	105	105
Power Up Status		Output @ min. value	Output @ min. value	Output @ min. value	Output @ min. value
Short Circuit Protection		Yes	Yes	Yes	Yes
Module ID (Pin 9)	KΩ	N/A	N/A	5.23	5.23
Isolation Voltage					
Field to Logic	Vrms	2500	2500	2500	2500
Field to Power	Vrms	2500	2500	2500	2500
Module to Module	Vrms	2500	2500	2500	2500
Channel A to Channel B		N/A	N/A	None	None
Environmental Conditions					
Operating Temperature	°C	0-60	0-60	-40-85	-40-85
Storage Temperature	°C	-25-85	-25-85	-40-100	-40-100

¹ Includes offset, gain, non-linearity and repeatability error terms.

² Accuracy and drift graphs are available in Bulletin #753.

CIRCUITRY: Current Output

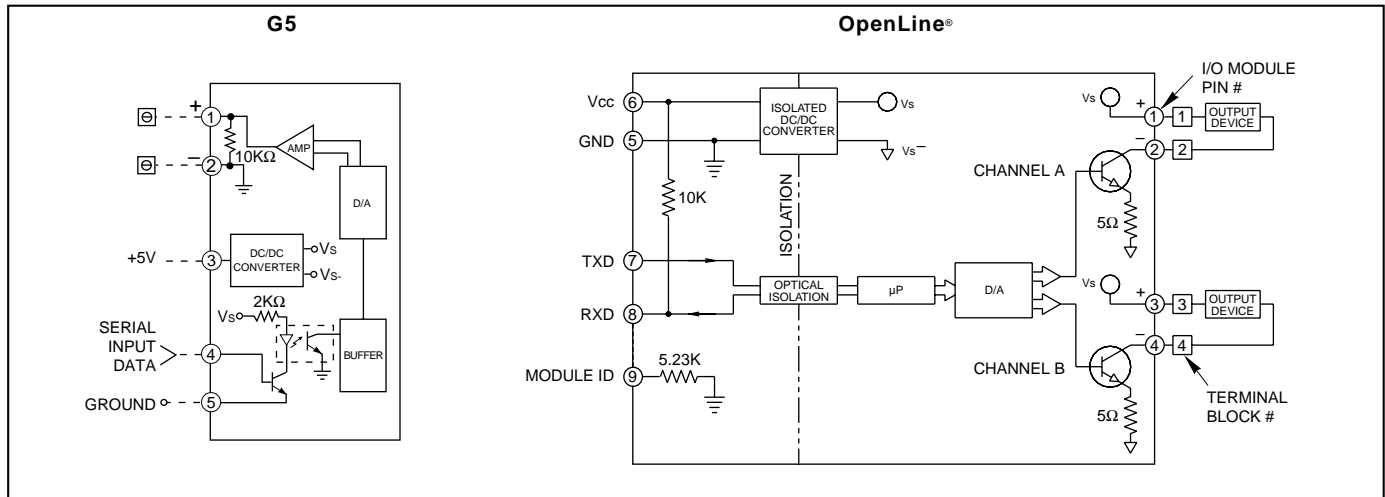

SPECIFICATIONS: By Part Number

Type/Function		Grayhill Part Number				
G5, OpenLine®		73G-OI420	73G-OI020	73L-OI420	73L-OI020	73L-OI024
Specifications	Units					
Number of Outputs		1 Ch., Diff.	1 Ch., Diff.	2 Ch., S.E.	2 Ch., S.E.	2 Ch., S.E.
Resolution	bits	12	12	12	12	12
Absolute Accuracy @ 25°C ¹	µA/count	3.9	4.9	3.9	4.9	5.9
Accuracy Drift w/Temp. ²						
Maximum Offset	PPM/°C	+/- 45	+/- 45	+/- 50	+/- 50	+/- 50
Maximum Gain (0 to 60°C)	PPM/°C	+/- 150	+/- 150	+/- 100	+/- 75	+/- 100
Serial Data Format		12-bit packet	12-bit packet	Right Justified, 16-bit	Right Justified, 16-bit	Right Justified, 16-bit
Serial Data Packet		—	—	115.2Kb, N, 8, 2	115.2Kb, N, 8, 2	115.2Kb, N, 8, 2
Step Response Time	µS	0.5	0.5	500	500	500
Max. Loop Resistance ³	Ohms	330	330	500	500	500
Output Current Range	mA	4-20	0-20	4-20	0-20	0-24
Maximum Load	Ω	250	1000	Continuous short circuit	Continuous short circuit	Continuous short circuit
Logic Voltage Range	Vdc	4.5-5.5	4.5-5.5	4.75-5.25	4.75-5.25	4.75-5.25
Maximum Logic Supply Current @ 5V dc	mA/Ch.	140	140	80	80	100
Power Up Status		Output @ min. value	Output @ min. value	Output @ min. value	Output @ min. value	Output @ min. value
Short Circuit Protection		Yes	Yes	Yes	Yes	Yes
Module ID (Pin 9)	KΩ	N/A	N/A	5.23	5.23	5.23
Isolation Voltage						
Field to Logic	Vrms	2500	2500	2500	2500	2500
Field to Power	Vrms	2500	2500	2500	2500	2500
Module to Module	Vrms	2500	2500	2500	2500	2500
Channel A to Channel B		N/A	N/A	None	None	None
Environmental Conditions						
Operating Temperature ^{3, 4}	°C	0-60	0-60	-40-85	-40-85	-40-85
Storage Temperature	°C	-25-55	-25-55	-40-100	-40-100	-40-100

¹ Includes offset, gain, non-linearity and repeatability error terms.

² Accuracy and drift graphs are available in Bulletin #753.

³ External loop supply can increase maximum loop resistance rating.

Available from your local Grayhill Distributor.

For prices and discounts, contact a local Sales Office, an authorized local Distributor or Grayhill.