

NO	DESCRIPTION	DATE
△1	5/8"-24UNEF - 1/2"-28UNEF	10.16.01
△2	BACKGROUND FORMAT UPDATED	09.18.03

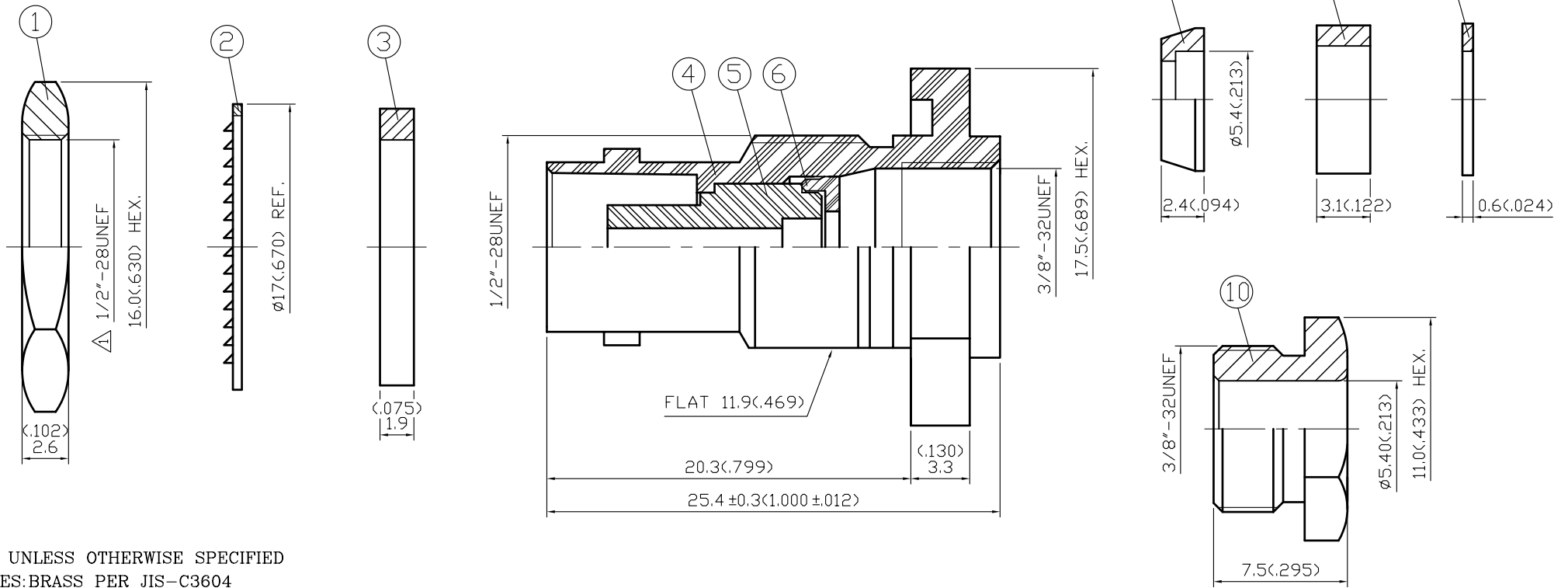

NOTES: UNLESS OTHERWISE SPECIFIED

- BODIES: BRASS PER JIS-C3604
- CENTER CONTACT: PHOSPHOR BRONZE JIS-H3270
- INSULATION: TEFLON PER ASTM D1457 AND ASTM D1710
- CONNECTOR INTERFACE PER MIL-STD-348A
- PART TO BE CLEAN AND FREE OF BURRS

11	CENTER CONTACT	Be Cu	1	SILVER 70 μ " MIN.
10	NUT	BRASS	1	SILVER 70 μ " MIN.
9	WASHER	BRASS	1	SILVER 70 μ " MIN.
8	GASKET	SILICONE	1	NONE
7	BRAID CLAMP	BRASS	1	SILVER 70 μ " MIN.
6	WASHER	BRASS	1	SILVER 70 μ " MIN.
5	INSULATION	TEFLON	1	NONE
4	BODY	BRASS	1	SILVER 70 μ " MIN.
3	GASKET	SILICONE	1	NONE
2	WASHER	IRON	1	SILVER 70 μ " MIN.
1	NUT	BRASS	1	SILVER 70 μ " MIN.
NO	DESCRIPTION	MATERIAL	Q'TY	FINISH

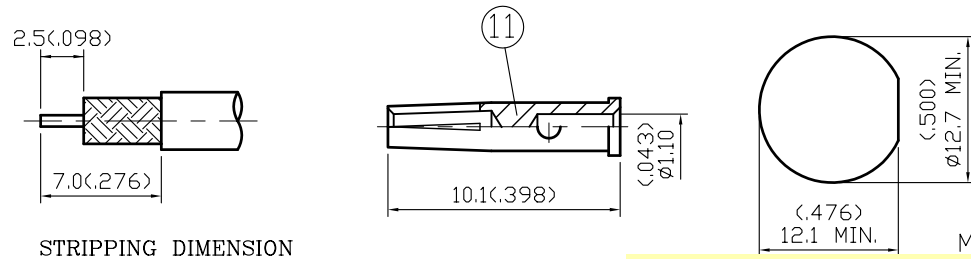

STRIPPING DIMENSION

SCALE 2:1
MOUNTING HOLE

FARNELL ORDER CODE: 3241439

製圖	DRAWN	TOLERANCE	品名	13-02-4 58U (50U)	DATE	版次	REV.
	梁齡允						
檢圖	CHECK	單位	UNIT	DWG.NO.	13-0118		
	沈淑美						
認定	APPROVAL	比例	SCALE	佳楠精密電子股份有限公司 CHIN NAN PRECISION ELECTRONICS CO.,LTD.			
	蘇文申						
	蘇文申	ANGLE	±5°				