



Description

The body is made from an extruded stove enamelled aluminium section and fitted with hard coated aluminium end plates having right and left hand threads, these should only be removed using the correct size face spanner.

Vibration is produced by the centrifugal force of the positive and negative unbalanced moments in the rotor. The rotor is supported on two heavy duty pre-lubricated matched sealed bearings. A special high performance grease ensures a long working life.

The inner and outer raceways of the bearings are designed so that the bearings can easily be removed without using special tools.

Maximum temperature 120°C = 250°F
Noise level range 60 to 75 dBA

Application

The GT range of turbine vibrators are particularly suitable for use in the Food and Pharmaceutical industries where exhaust contaminated with oil is unacceptable. No lubrication is required, but clean filtered air is essential.

These vibrators are extremely quiet and produce low noise levels on most applications, thus helping to conform with noise regulations.

Stainless Steel

Models GT10, GT16, GT20 and GT25 are available in stainless steel especially suitable for the use in chemically hazardous applications.

PNEUMATIC TURBINE VIBRATORS

Model GT

VIBRATECHNIQUES LTD

2 CHAPEL ROAD PORTSLADE
BRIGHTON BN41 1PF

ENGLAND

Tel. +44 (0)1273 430977

Fax. +44 (0)1273 430978

E-mail. sales@vibtec.com

Internet. www.vibtec.com

VIBTEC

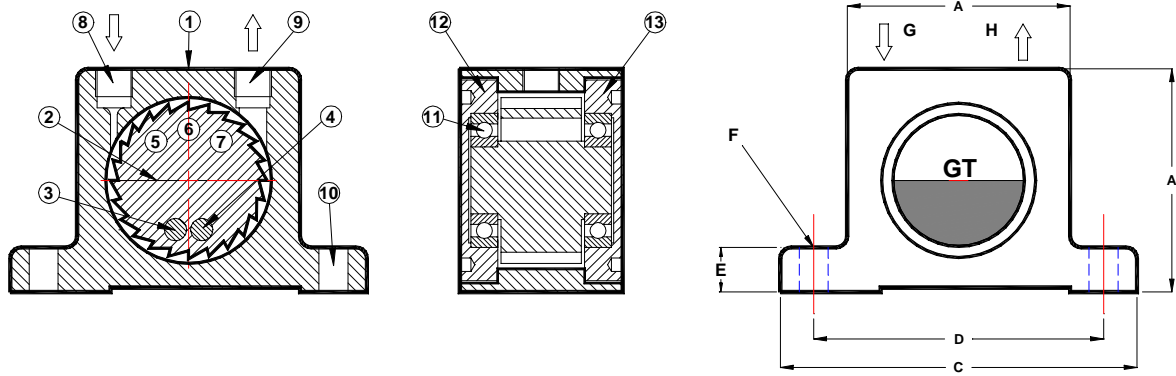

- | | |
|---------------------------------------|---|
| 1 Extruded aluminium alloy body | 10 Base mounting holes |
| 2 Alu-Turbine wheel, hard coated | 11 Special pre-lubricated matched sealed bearings |
| 3/4 High density mass positive moment | |
| 5/7 Cavities giving negative moment | Alu-Endplates, hard coated |
| 8 Air inlet | 12 with lefthand thread |
| 9 Air exhaust | 13 with righthand thread |

PERFORMANCE DATA

Type	Frequency V.P.M.			Centrifugal Force						Air Consumption/Minute					
	2 Bar PSI	29 Bar PSI	4 58 Bar PSI	6 87 Bar PSI	2 Bar N	29 PSI LBS	4 Bar N	58 PSI LBS	6 Bar N	87 PSI LBS	2 Bar Litr.	29 PSI CF	4 Bar Litr.	58 PSI CF	6 Bar Litr.
GT4	14000	15000	15000	135	30	180	40	200	44	33	1.1	58	2	83	2.9
GT6	11500	12000	12500	130	29	175	39	210	47	33	1.1	58	2	83	2.9
GT8	36000	42000	46000	563	126	766	172	919	206	46	1.6	80	2.8	112	3.9
GT10	27500	35000	37500	583	131	946	212	1086	243	46	1.6	80	2.8	112	3.9
GT10S	17000	23000	25000	650	146	1350	303	2000	448	46	1.6	80	2.8	112	3.9
GT13	26000	30000	33000	1451	325	1932	433	2338	524	120	4.2	200	7.0	290	10.2
GT16	17000	21500	24000	1103	247	1764	396	2198	493	120	4.2	200	7.0	290	10.2
GT16S	11500	15500	17000	1100	247	1900	426	2700	605	120	4.2	200	7.0	290	10.2
GT20	17000	20000	23000	2014	452	2787	625	3686	826	185	6.6	325	11.4	455	15.9
GT25	12000	15500	17000	1784	400	2977	667	3581	803	185	6.6	325	11.4	455	15.9
GT25S	8500	11000	13000	2250	504	3600	807	4900	1098	185	6.6	325	11.4	455	15.9
GT30	13000	14000	16000	4603	1032	5339	1197	6073	1563	330	11.5	530	18.5	745	26.0
GT36	8000	10000	13000	3060	686	4781	1072	8080	1812	330	11.5	530	18.5	745	26.0
GT36S	6100	7200	8300	4100	919	6200	1390	7500	1681	330	11.5	530	18.5	745	26.0
GT40	7700	8800	9500	4300	964	7300	1636	9800	2197	425	15	700	24.7	970	34.2
GT48	6000	7500	9700	4900	1098	7700	1726	10500	2354	425	15	700	24.7	970	34.2
GT48S	-	5600	6300	-	-	7500	1681	12000	2690	425	15	700	24.7	970	34.2

DIMENSIONS

Type	A		B Width		C		D		E		F Hole Dia.		G/H	Weight	
	mm	inch	mm	inch	mm	inch	mm	inch	mm	inch	mm	inch		BSP	kg
GT4	40	1.57	28	1.10	70	2.75	56	2.20	10	0.39	6	0.23	1/8"	.165	.55
GT6														.250	.37
GT8														.165	.55
GT10	50	1.97	33	1.30	86	3.38	68	2.68	12	0.47	7	0.27	1/8"	.255	.56
GT10S														.263	.58
GT13														.565	1.24
GT16	65	2.56	42	1.65	113	4.45	90	3.54	16	0.63	9	0.35	1/4"	.580	1.28
GT16S														.614	1.35
GT20														1.090	2.40
GT25	80	3.15	56	2.20	128	5.04	104	4.09	16	0.63	9	0.35	1/4"	1.120	2.46
GT25S														1.200	2.64
GT30														2.200	4.85
GT36	100	3.94	73	2.87	160	6.30	130	5.12	20	0.79	11	0.43	3/8"	2.300	5.10
GT36S														2.530	5.57
GT40														3.690	8.13
GT48	120	4.72	83	3.26	194	7.63	152	5.98	24	0.94	17	0.66	3/8"	3.890	8.57
GT48S														4.290	9.45

Data on a heavy laboratory block. Frequency and force will decrease on a less rigid mount.