

Compact Cylinder Series CQ2

ø12, ø16, ø20, ø25, ø32, ø40, ø50, ø63, ø80, ø100, ø125, ø140, ø160 ø180, ø200

With a short overall length, the space saving cylinder helps to make various jigs and equipment more compact.

Variations

Series	Action	Style	Options	Bore size (mm)	Standard stroke (mm)	Page
Standard 	Double acting	Single rod CQ2	Basic	12, 16, 20, 25 32, 40, 50, 63 80, 100	ø12, ø16/5 to 30 ø20, ø25/5 to 50 ø32, ø40/5 to 100 ø50 to ø100/10 to 100	2.3-2
		Double rod CQ2W	Built-in magnet	12, 16, 20, 25 32, 40, 50, 63 80, 100	ø12, ø16/5 to 30 ø20, ø40/5 to 50 ø32, ø40/5 to 100 ø50 to ø100/10 to 100	2.3-22
	Single acting	Spring return/extend CQ2	Mounting female thread (A) Rod end male thread With rubber bumper Rear boss mount	12, 16, 20 25, 32, 40 50	ø12 to ø40/5, 10 ø50/10, 20	2.3-38
Non-rotating rod 	Double acting	Single rod CQ2K		12, 16, 20 25, 32, 40 50, 63	ø12, ø16/5 to 30 ø20, ø25/5 to 50 ø32, ø40/5 to 100 ø50, ø63/10 to 100	2.3-56
		Double rod CQ2KW		12, 16, 20 25, 32, 40 50, 63	ø12, ø16/5 to 30 ø20, ø40/5 to 50 ø50, ø63/10 to 50	2.3-70
Axial piping (Centralized piping) 	Double acting	Single rod CQP2		12, 16, 20, 25 32, 40, 50, 63, 80, 100	ø12, ø16/5 to 30 ø20, ø25/5 to 50 ø32, ø40/5 to 100 ø50 to ø100/10 to 100	2.3-82
	Single acting	Spring return/extend CQP2		12, 16, 20 25, 32, 40 50	ø12 to ø40/5, 10 ø50/10, 20	2.3-90
Large bore size 	Double acting	Single rod CQ2		125, 140 160	10 to 300	2.3-100
		Double rod CQ2W		125, 140 160	10 to 300	2.3-104
		Single rod CQ2		180, 200	10 to 300	2.3-109
		Double rod CQ2W		180, 200	10 to 300	2.3-113
Long stroke 	Double acting	Single rod CQ2		32, 40, 50 63, 80 100	125 to 300	2.3-118
Anti-lateral load 	Double acting	Single rod CQ2□S	With One-touch fitting (Bore size ø32 to ø63) Foot and flange Double clevis Copper free Air-hydro (Bore ø20 to ø100) Clean series (Bore ø12 to ø63)	32, 40, 50 63, 80 100	ø32 to ø40/5 to 100 ø50 to ø100/10 to 100	2.3-128

CUJ
CU
CQS
CQ2
RQ
MU

Applicable Auto Switch

Reed switch	D-A7□/A80, D-A73C/A80, D-A9□ D-A7□H/A80H, D-A79W, D-A9□V
Solid state switch	D-F7□/J79, D-F7□V, D-J79C, D-F7□W/J79W, D-F7□WV, D-F7BA, D-F7□F, D-F7NT, D-F9□, D-F9□W, D-F9□V, D-F9□WV

Made to Order

Refer to p.5.4-1 for made to order specifications of CQ2 series.

Compact Cylinder/Standard: Double Acting Single Rod

Series CQ2

ø12, ø16, ø20, ø25, ø32, ø40, ø50, ø63, ø80, ø100

How to Order

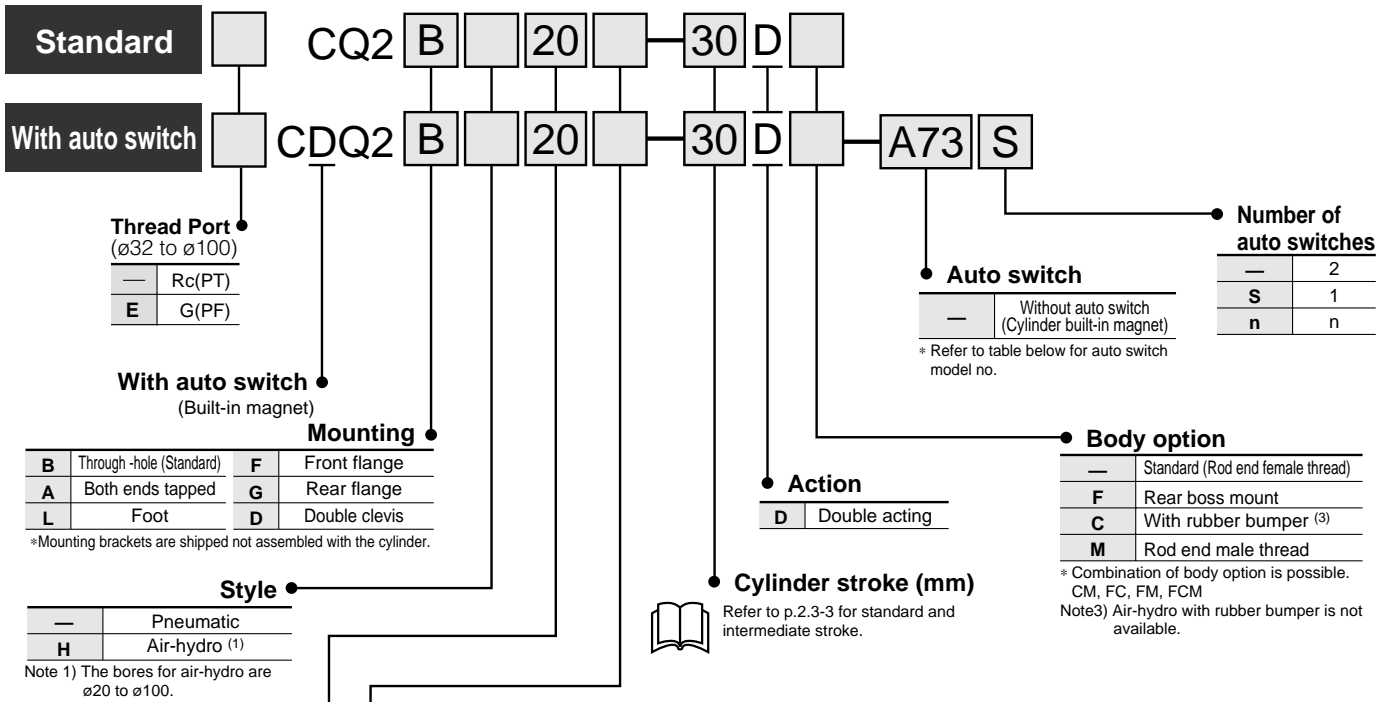

Applicable Auto switches/Refer to p.5.3-2 for further information on auto switch.

Style	Special function	Electrical entry	Indicator	Wiring (Output)	Load voltage		Rail mounting		Direct mounting		Lead wire*(m)				Applicable load																														
					DC	AC	ø12 to ø100		ø32 to ø100		0.5 (-)	3 (L)	5 (Z)	None (N)																															
							Perp.	In-line	Perp.	In-line																																			
Reed switch	—	Grommet	Yes	3 wire (Equiv. NPN)	—	5V	—	—	A76H	A96V	A96	●	●	—	—	IC																													
																	24V	12V	100V	A72	A72H	—	—	●	●	—	—	—																	
																				A73	A73H	—	—	●	●	—	—																		
																	Reed switch	—	Connector	No	2 wire	—	5V, 12V	≤100V	A80	A80H	A90V	A90	●	●	—	—	IC												
																																		24V	12V	≤24V	A73C	—	—	—	●	●	●	●	—
																																					A80C	—	—	—	●	●	—	—	
—	—	—	—	A79W	—	—	—	●	●	—	—																																		
Solid state switch	—	Grommet	Yes	3 wire (NPN)	—	5V, 12V	—	—	F7NV	F79	—	—	●	●	○	—	IC																												
																		24V	12V	—	—	F9NV	F9N	—	—	●	●	—	—																
																						F7PV	F7P	—	—	●	●	○	—																
																		24V	12V	—	—	—	—	F9PV	F9P	—	—	●	●	—	—														
																						F7BV	J79	—	—	●	●	○	—																
																		24V	12V	—	—	J79C	—	—	—	—	—	●	●	●	●	—													
		F7NWV	F79W	—	—	—	—	—	—	●	●	○	—																																
		Solid state switch	Diagnostic (2 colour)	Grommet	Yes	3 wire (PNP)	—	5V, 12V	—	—	—	—	—	—	—	—	—	—	IC																										
																				24V	12V	—	—	F9NWV	F9NW	—	—	●	●	○	—														
																								—	—	F7PW	—	—	—	●	●	○	—												
																				24V	12V	—	—	—	—	F9PWW	F9PW	—	—	●	●	○	—												
																								—	—	F7BWV	J79W	F9BWW	F9BW	—	—	●	●	○	—										
24V	12V																			—	—	—	—	F7BA	—	F9BA	—	—	●	●	○	—													
		—	—	F7NT	—	—	—	—	—	●	●	○	—																																
24V	12V	—	—	4 wire (NPN)	—	—	—	—	—	—	—	—	—	—	—	—																													
				—	—	F79F	—	—	—	—	—	●	●	○	—																														
24V	12V	—	—	—	—	—	—	—	—	—	—	—	—	—	—	—																													
				—	—	F7LF	—	—	—	—	—	●	●	○	—																														

Note 4) 2 pcs. per cylinder should be ordered when foot brackets are required.
 Note 5) Each package contains the following parts.
 Foot, Flange: Body mounting bolt
 Double clevis: Clevis pin, C shape snap ring for axis, body mounting bolt
 Note 6) Package for double clevis contains clevis pin and snap ring.

*Lead wire length 0.5m..... (Example) A80C 5m..... Z (Example) A80CZ
 3m..... L (Example) A80CL None..... N (Example) A80CN
 *Solid state switches marked with a "○" are manufactured upon receipt of order.

Refer to p.2.3-6 for parts No. of auto switch mounting brackets.

Compact Cylinder/Standard: Double Acting Single Rod **Series CQ2**



Style

Bore size (mm)		12	16	20	25	32	40	50	63	80	100	
Pneumatic	Mounting	Through-hole (Standard)	●	●	●	●	●	●	●	●	●	
		Both ends tapped	●	●	●	●	●	●	●	●	●	
	Built-in magnet		●	●	●	●	●	●	●	●	●	
	Piping	Screw-in style	M5 X 0.8	M5 X 0.8	M5 X 0.8	M5 X 0.8	M5 X 0.8 ⁽¹⁾	1/8	1/4	1/4	3/8	3/8
		With One-touch fitting	—	—	—	—	ø6/4 ⁽²⁾	ø6/4	ø8/6	ø8/6	—	—
	Rod end male thread		●	●	●	●	●	●	●	●	●	●
	With rubber bumper		●	●	●	●	●	●	●	●	●	●
	Rear boss mount		●	●	●	●	●	●	●	●	●	●
	Air-hydro	Mounting	Through hole (Standard)	—	—	●	●	●	●	●	●	●
			Both ends tapped	—	—	●	●	●	●	●	●	●
Built-in magnet		—	—	●	●	●	●	●	●	●		
Piping		Screw-in style	—	—	M5 X 0.8	M5 X 0.8	M5 X 0.8 ⁽¹⁾	1/8	1/4	1/4	3/8	3/8
		With One-touch fitting	—	—	—	—	—	—	—	—	—	—
Rod end male thread		—	—	●	●	●	●	●	●	●	●	
Rear boss mount		—	—	●	●	●	●	●	●	●	●	

Note 1) Among those without an auto switch, only the 5mm stroke uses M5 X 0.8 piping.

Note 2) Among those with a built-in fitting, the 5mm stroke with the ø32 bore has the same outer dimensions as the 10mm stroke.

Specifications

Style	Pneumatic (Non-lube)	Air-hydro
Fluid	Air	Turbine oil ⁽¹⁾
Proof pressure	1.5MPa	
Max. operating pressure	1.0MPa	
Ambient and fluid temperature	Without auto switch: -10°C to 70°C (No freezing)	
	With auto switch: -10°C to 60°C (No freezing)	
Rubber bumper	None	—
Rod end thread	Female thread	
Tolerance of rod end thread	JIS class 2	
Tolerance of stroke length	+1.0 0	
Mounting	Through-hole	
Piston speed	50 to 500mm/s	5 to 50mm/s

Note 1) Refer to p.0-43 for precautions.

Note 2) For applications involving lateral loads, refer to the "Lateral Load Resistant Style" on p.2.3-128.

Minimum Operating Pressure

Unit: MPa

Bore size (mm)	12	16	20	25	32	40	50	63	80	100
Pneumatic (Non-lube)	0.07		0.05							
Air-hydro	—			0.18			0.10			

Intermediate Strokes

Style	Standard body	Exclusive body (-XB10)		
Model No.	Refer to "How to Order" for standard model No. on p.2.3-2.	Specify "-XB10" at the end of the standard model No. shown on p.2.3-2.		
Method	Intermediate strokes at 1mm increments are available by using a spacer with standard stroke cylinders.	Intermediate strokes at 1mm increments are available by using an exclusive body for required stroke.		
Stroke range	Bore size	Bore size		
	Stroke range	Stroke range		
	12, 16	1 to 29	12, 16	6 to 29
	20, 25	1 to 49	20, 25	6 to 49
	32 to 100	1 to 99	32, 40	6 to 99
			50 to 100	11 to 99
Example	Model No.: CQ2B50-57D A 18mm width spacer is installed in the standard CQ2B50-75D. B dimension is 115.5mm.	Model No. CQ2B50-57D-XB10 Makes an exclusive body for 57mm stroke. B dimension is 97.5mm.		



- Consult us when intermediate strokes with a spacer are required for ø40 to ø100 rubber bumper models.
- Reference values for length dimensions are different in case of ø32 to ø100 exclusive body models (-XB10) with a stroke exceeding 50mm. Calculate length dimensions by deducting from those of 75 or 100mm stroke models.
- Refer to long stroke styles of CQ2 (P.2.3-108) for strokes exceeding the stroke range.

JIS symbol

Double acting: Single rod

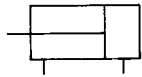

Symbol

Rear boss mount

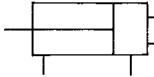

Made to Order Specifications

Refer to p.5.4-1 for common made to order specifications and p.5.4-79 for individual specifications.

Allowable Kinetic Energy

Refer to p.2.3-4 for allowable kinetic energy.

Standard Stroke

Pneumatic

Bore size (mm)	Standard stroke (mm)
12, 16	5, 10, 15, 20, 25, 30
20, 25	5, 10, 15, 20, 25, 30, 35, 40, 45, 50
32, 40	5, 10, 15, 20, 25, 30, 35, 40, 45, 50, 75, 100
50 to 100	5, 10, 15, 20, 25, 30, 35, 40, 45, 50, 75, 100

• Refer to p.2.3-108 when stroke exceeds standard range.

Air-hydro

Bore size	Standard stroke (mm)
20, 25	5, 10, 15, 20, 25, 30, 35, 40, 45, 50
32, 40	5, 10, 15, 20, 25, 30, 35, 40, 45, 50, 75, 100
50, 63 80, 100	10, 15, 20, 25, 30, 35, 40, 45, 50, 75, 100

⚠ Precautions

Be sure to read before handling. Refer to p.0-39 to 0-46 for Safety Instructions and common precautions.

⚠ Caution

Snap Ring Installation/Removal

① For installation and removal, use an appropriate pair of pliers (tool for installing a C snap ring).

② Exercise caution even when using an appropriate pair of pliers (tool for installing a C snap ring), because of the possibility of the snap ring becoming detached from the tip of the pliers (tool for installing a C snap ring) and flying away, which could injure humans or damage the peripheral equipment. After installing the snap ring, make sure that it is placed securely in the ring groove before supplying air.

Allowable Kinetic Energy

Table 1: Load weight and Piston speed

[J] 1J ≒ 0.102kgf/m

Bore size (mm)	12	16	20	25	32	40	50	63	80	100
Standard allowable kinetic energy: Ea	0.022	0.038	0.055	0.09	0.15	0.26	0.46	0.77	1.36	2.27
With rubber bumper allowable kinetic energy: Eb	0.043	0.075	0.110	0.18	0.29	0.52	0.91	1.54	2.71	4.54

$$\text{Kinetic energy } E(J) = \frac{(m1+m2) V^2}{2}$$

m1: Weight of cylinder operating part kg
 m2: Load weight kg
 V: Piston speed m/s

Table 2: Weight of cylinder operating part/Without magnet

Unit: g

Bore (mm)	Cylinder stroke (mm)											
	5	10	15	20	25	30	35	40	45	50	75	100
12	5	6	7	8	10	11	-	-	-	-	-	-
16	9	11	13	15	17	19	-	-	-	-	-	-
20	15	18	21	24	27	31	34	37	40	44	-	-
25	24	28	33	37	42	46	51	55	60	64	-	-
32	45	52	60	68	76	84	92	100	107	115	170	209
40	64	72	80	88	96	104	112	119	127	135	190	229
50	-	117	129	141	153	166	178	190	202	214	300	361
63	-	153	165	177	190	202	214	226	239	251	337	398
80	-	270	289	308	327	347	366	385	404	423	557	653
100	-	487	515	543	570	598	625	653	681	708	901	1038

Table 3: Weight of cylinder operating part/With magnet

Unit: g

Bore (mm)	Cylinder stroke (mm)											
	5	10	15	20	25	30	35	40	45	50	75	100
12	8	9	10	11	12	13	-	-	-	-	-	-
16	16	18	20	22	24	26	-	-	-	-	-	-
20	28	31	34	37	40	44	47	50	53	56	-	-
25	44	48	53	57	62	66	71	75	80	84	-	-
32	78	86	93	101	109	117	125	133	140	148	187	227
40	109	117	125	133	140	148	156	164	172	180	219	258
50	-	187	199	211	223	236	248	260	272	285	346	407
63	-	254	266	278	290	303	315	327	339	352	413	474
80	-	433	453	472	491	510	530	549	568	587	683	778
100	-	741	768	796	823	851	879	906	934	962	1099	1236

Table 4

Unit: g

Bore (mm)		12	16	20	25	32	40	50	63	80	100
Rod end male thread	Male thread portion	1.5	3	6	12	26	27	53	53	120	175
	Nut	1	2	4	8	17	17	32	32	49	116
With rubber bumper		0	0	-2	-3	-3	-7	-9	-18	-31	-56

Calculation example: CDQ2B32-20DCM

- Cylinder weight: CDQ2B32-20D 101g
 - Option weight: Rod end male thread 43g
 - : With rubber bumper -3g
- 141g

Allowable Lateral Load at Rod End

Without auto switch (anti-lateral)

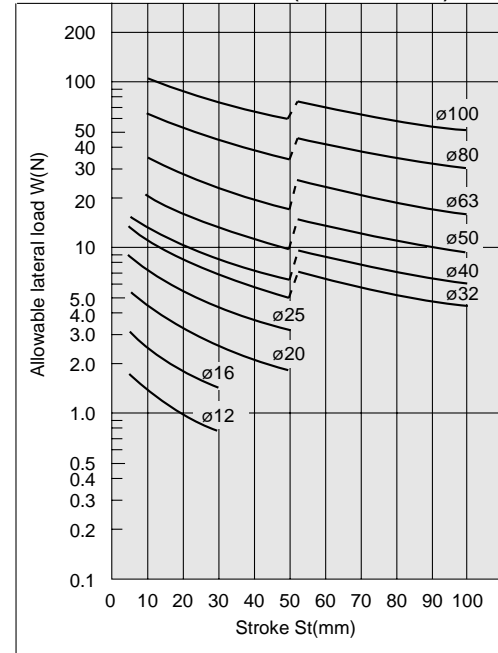

With auto switch (anti-lateral)

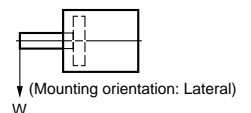
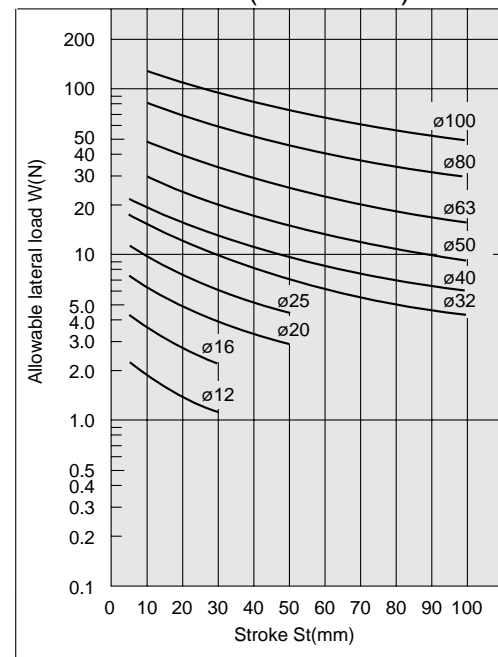

Compact Cylinder/Standard: Double Acting Single Rod Series CQ2

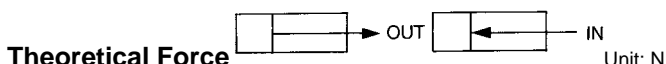

Bore size (mm)	Operation	Operating pressure (MPa)		
		0.3	0.5	0.7
12	IN	25	42	59
	OUT	34	57	79
16	IN	45	75	106
	OUT	60	101	141
20	IN	71	118	165
	OUT	94	157	220
25	IN	113	189	264
	OUT	147	245	344
32	IN	181	302	422
	OUT	241	402	563
40	IN	317	528	739
	OUT	377	628	880
50	IN	495	825	1150
	OUT	589	982	1370
63	IN	841	1400	1960
	OUT	935	1560	2180
80	IN	1360	2270	3170
	OUT	1510	2510	3520
100	IN	2140	3570	5000
	OUT	2360	3930	5500

Mounting Bolt for CQ2

Special long bolt for through-hole mounting is available.

How to Order: Specify the required bolts.

Example) Bolt M3 X 25 ℓ 4pcs.

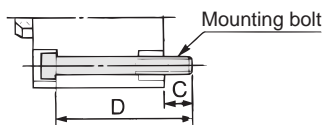

Model No.	C	D	Mounting bolt
CQ2B12-5D	6.5	25	M3 X 25 ℓ
-10D		30	X 30 ℓ
-15D		35	X 35 ℓ
-20D		40	X 40 ℓ
-25D		45	X 45 ℓ
-30D		50	X 50 ℓ
CQ2B16-5D	5	25	M3 X 25 ℓ
-10D		30	X 30 ℓ
-15D		35	X 35 ℓ
-20D		40	X 40 ℓ
-25D		45	X 45 ℓ
-30D		50	X 50 ℓ
CQ2B20-5D	7.5	25	M5 X 25 ℓ
-10D		30	X 30 ℓ
-15D		35	X 35 ℓ
-20D		40	X 40 ℓ
-25D		45	X 45 ℓ
-30D		50	X 50 ℓ
-35D		55	X 55 ℓ
-40D		60	X 60 ℓ
-45D		65	X 65 ℓ
-50D		70	X 70 ℓ
CQ2B25-5D	9.5	30	M5 X 30 ℓ
-10D		35	X 35 ℓ
-15D		40	X 40 ℓ
-20D		45	X 45 ℓ
-25D		50	X 50 ℓ
-30D		55	X 55 ℓ
-35D		60	X 60 ℓ
-40D		65	X 65 ℓ
-45D		70	X 70 ℓ
-50D		75	X 75 ℓ

Model No.	C	D	Mounting bolt	
CQ2B32-5D	9	30	M5 X 30 ℓ	
-10D		35	X 35 ℓ	
-15D		40	X 40 ℓ	
-20D		45	X 45 ℓ	
-25D		50	X 50 ℓ	
-30D		55	X 55 ℓ	
-35D		60	X 60 ℓ	
-40D		65	X 65 ℓ	
-45D		70	X 70 ℓ	
-50D		75	X 75 ℓ	
CQ2B40-5D	7.5	35	M5 X 35 ℓ	
-10D		40	X 40 ℓ	
-15D		45	X 45 ℓ	
-20D		50	X 50 ℓ	
-25D		55	X 55 ℓ	
-30D		60	X 60 ℓ	
-35D		65	X 65 ℓ	
-40D		70	X 70 ℓ	
-45D		75	X 75 ℓ	
-50D		80	X 80 ℓ	
CQ2B50-10D	12.5	115	X 115 ℓ	
-100D		140	X 140 ℓ	
CQ2B50-10D		12.5	45	M6 X 45 ℓ
-15D			50	X 50 ℓ
-20D			55	X 55 ℓ
-25D			60	X 60 ℓ
-30D			65	X 65 ℓ
-35D			70	X 70 ℓ
-40D			75	X 75 ℓ
-45D			80	X 80 ℓ
-50D	85		X 85 ℓ	
-75D	120		X 120 ℓ	
-100D	145	X 145 ℓ		

Model No.	C	D	Mounting bolt
CQ2B63-10D	14.5	50	M8 X 50 ℓ
-15D		55	X 55 ℓ
-20D		60	X 60 ℓ
-25D		65	X 65 ℓ
-30D		70	X 70 ℓ
-35D		75	X 75 ℓ
-40D		80	X 80 ℓ
-45D		85	X 85 ℓ
-50D		90	X 90 ℓ
-75D		125	X 125 ℓ
CQ2B80-10D	15	55	M10 X 55 ℓ
-15D		60	X 60 ℓ
-20D		65	X 65 ℓ
-25D		70	X 70 ℓ
-30D		75	X 75 ℓ
-35D		80	X 80 ℓ
-40D		85	X 85 ℓ
-45D		90	X 90 ℓ
-50D		95	X 95 ℓ
-75D		130	X 130 ℓ
CQ2B100-10D	15.5	65	M10 X 65 ℓ
-15D		70	X 70 ℓ
-20D		75	X 75 ℓ
-25D		80	X 80 ℓ
-30D		85	X 85 ℓ
-35D		90	X 90 ℓ
-40D		95	X 95 ℓ
-45D		100	X 100 ℓ
-50D		105	X 105 ℓ
-75D		140	X 140 ℓ
-100D	165	X 165 ℓ	

Weight

Unit: g

Bore size (mm)	Cylinder stroke (mm)											
	5	10	15	20	25	30	35	40	45	50	75	100
12	29	35	41	47	54	60	-	-	-	-	-	-
16	42	50	59	67	76	84	-	-	-	-	-	-
20	63	75	88	101	114	127	140	152	165	178	-	-
25	86	100	115	129	144	158	173	187	202	216	-	-
32	131	152	173	193	214	235	256	277	297	318	471	576
40	206	229	252	275	298	321	344	367	390	413	597	717
50	-	369	405	441	477	514	550	586	622	659	951	1139
63	-	538	579	620	661	702	742	783	824	865	1213	1424
80	-	997	1064	1132	1200	1268	1336	1404	1471	1539	2111	2446
100	-	1738	1829	1920	2011	2101	2192	2283	2374	2464	3269	3729

Option Weight

Unit: g

Bore size (mm)	12	16	20	25	32	40	50	63	80	100
Both ends tapped	2	2	6	6	6	6	6	19	45	45
Rod end male thread	Male thread portion	1.5	3	6	12	26	27	53	53	120
	Nut	1	2	4	8	17	17	32	32	49
Rear boss mount	0.7	1.3	2	3	5	7	13	25	45	96
With rubber bumper	0	0	-2	-3	-3	-7	-9	-18	-31	-56
With One-touch fitting	-	-	-	-	12	12	21	21	-	-
Foot mounting (including bolt)	55	67	164	186	143	155	243	324	696	1062
Front flange (including bolt)	57	69	139	161	180	214	373	559	1056	1365
Rear flange (including bolt)	54	65	133	152	165	198	348	534	1017	1309
Double clevis (pin, snap ring, bolt)	32	39	88	123	151	196	393	554	1109	1887

Calculation Example: CQ2D32-20DCM

- Cylinder weight: CQ2B32-20D 193g
 - Option weight: Both ends tapped 6g
 - Rod end male thread 43g
 - With rubber bumper -3g
 - Double clevis 151g
- 390g

CUJ

CU

CQS

CQ2

RQ

MU

Series CQ2

Construction

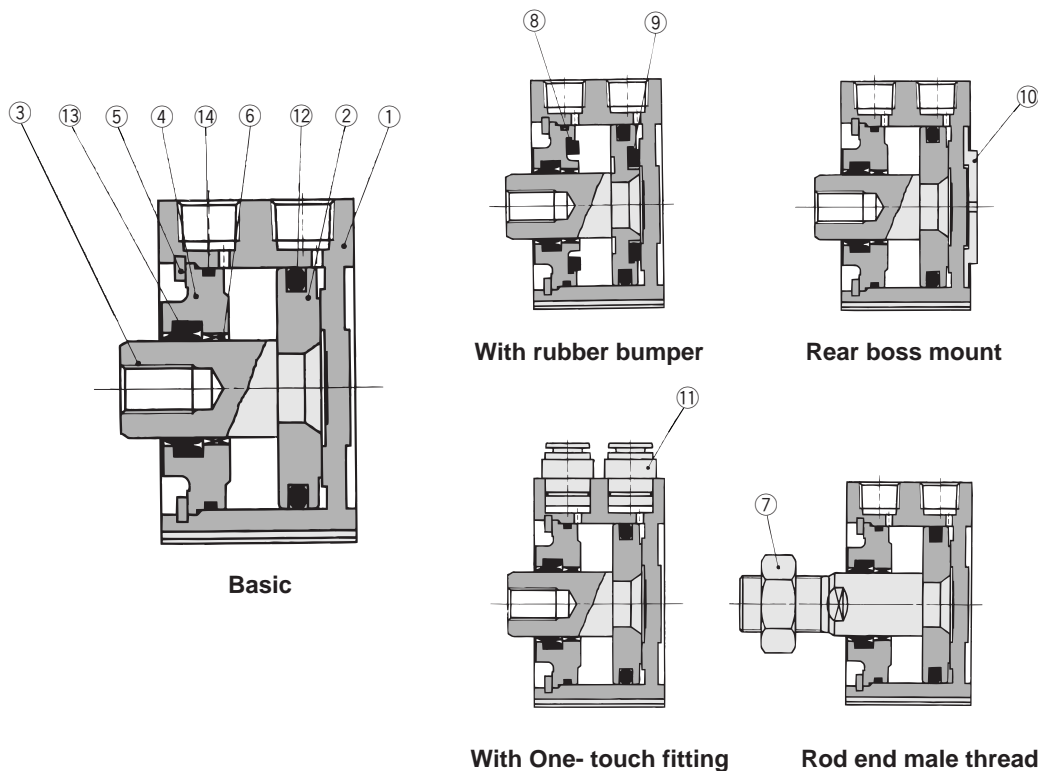

Component Parts

No.	Description	Material	Note
①	Cylinder tube	Aluminum alloy	Hard anodized
②	Piston*	Aluminum alloy	Chromated
③	Piston rod*	Stainless steel	ø12 to ø25
		Carbon steel	ø32 to ø100, Hard chrome plated
④	Collar	Aluminum bearing alloy	ø12 to ø40, Anodized
		Aluminum alloy casting	ø50 to ø100, Chromated, plated
⑤	Snap ring	Carbon tool steel	Phosphate coating
⑥	Bushing	Lead bronze casting	For ø50 or larger
⑦	Rod end nut	Carbon steel	Nickel plated
⑧	Bumper A	Urethane	

No.	Description	Material	Note
⑨	Bumper B	Resin	
⑩	Guide boss ring	Aluminum alloy	Hard anodized ø20 to ø100
⑪	One-touch fitting	—	ø32 to ø63
⑫	Piston seal	NBR	
⑬	Rod seal	NBR	
⑭	Gasket	NBR	

Replacement Parts: Seal Kits

Style	Bore size	Kit No.	Contents
Pneumatic style	12	CQ2B12-PS	Kits include items ⑫, ⑬ and ⑭ from the table above.
	16	CQ2B16-PS	
	20	CQ2B20-PS	
	25	CQ2B25-PS	
	32	CQ2B32-PS	
	40	CQ2B40-PS	
	50	CQ2B50-PS	
	63	CQ2B63-PS	
	80	CQ2B80-PS	
100	CQ2B100-PS		

Replacement Parts: Seal Kits

Style	Bore size	Kit No.	Contents
Air-hydro style	20	CQ2BH20-PS	Kits include items ⑫, ⑬ and ⑭ from the table above.
	25	CQ2BH25-PS	
	32	CQ2BH32-PS	
	40	CQ2BH40-PS	
	50	CQ2BH50-PS	
	63	CQ2BH63-PS	
	80	CQ2BH80-PS	
	100	CQ2BH100-PS	

* Seal kits consist of items ⑫, ⑬ and ⑭ contained in one kit, and can be ordered using the order number for each respective tube bore size.

Auto Switch Mounting Brackets Parts No.

Bore size (mm)	Mounting bracket part No.	Note	Applicable switch	
			Reed switch	Solid state switch
12/16 20/25	BQ-1	•Switch mounting screw (M3 X 0.5 X 8 ϕ) •Square nut	D-A7□, A80 D-A73C, A80C D-A7□H, A80H D-A79W	D-F7□, J79 D-F7□V D-J79C D-F7□W, J79W D-F7□WV D-F7BA D-F7□F D-F7NT
32/40 50/63 80/100	BQ-2	•Switch mounting screw (M3 X 0.5 X 10 ϕ) •Switch spacer •Switch mounting nut		

[Stainless steel mounting bolt set]

The set of stainless steel mounting screws (with nuts) described below is available and can be used depending on the operating environment. (The spacers for auto switches must be ordered separately, as they are not included.)

BBA2: For D-A7/A8/F7/J7 types

The stainless steel bolts described above are used when the D-F7BA type switch is shipped mounted on a cylinder. When the switches are shipped as individual parts, the BBA2 set is included.

Compact Cylinder/Standard: Double Acting Single Rod **Series CQ2**

Clean Series



The rod portion of the actuator has a double seal construction, and a relief port is provided to discharge the exhaust air directly outside of the clean room. Thus, it can be used in a Class 100 clean room.



Specifications

Action	Double acting single rod
Cylinder bore size	$\varnothing 12, \varnothing 16, \varnothing 20, \varnothing 25, \varnothing 32, \varnothing 40, \varnothing 50, \varnothing 63$
Proof pressure	1.5MPa
Max. operating pressure	1.0MPa
Rubber bumper	None (1)
Piping method	Screw-in piping
Piston speed	50 to 500mm/s
Mounting	Through-hole
Auto switch	Attachable

Note 1) $\varnothing 12$ with switch: With rubber bumper (Standard)

Construction

10-CQ2 Series (Double seal)

A relief port is provided in the area between the double rod seals to discharge the exhaust air outside of the clean room. Thus, the amount of dust generated has been reduced to 1/20 of that of an ordinary cylinder.

11-CQ2 Series (Single seal/Vacuum adsorption)

Structurally identical to the "10-" series, the outer rod seal has been removed to evacuate through the vacuum port. This draws out any external air from the clearance between the rod and the cover to practically eliminate the generation of external dust. This should be used in an application that requires an even higher level of cleanliness than the "10-" series.

Copper Free

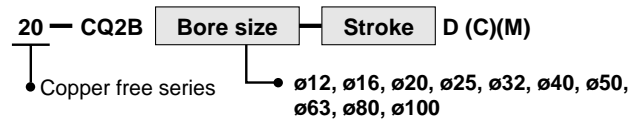

To eliminate influences of copper ions or halogen ions during CRT manufacturing processes, copper and fluorine materials are not used as component parts.



Specifications

Action	Double acting single rod
Cylinder bore size	$\varnothing 12, \varnothing 16, \varnothing 20, \varnothing 25, \varnothing 32, \varnothing 40, \varnothing 50, \varnothing 63, \varnothing 80, \varnothing 100$
Proof pressure	1.5MPa
Max. operating pressure	1.0MPa
Rubber bumper	With, Without
Piping method	Screw-in piping
Piston speed	50 to 500mm/s
Mounting	Through-hole, Both ends tapped
Auto switch	Attachable

Water Resistant

CDQ2 — Mounting — Bore size — **R** — Stroke — D — Option — F7BAL — XC6

- With auto switch (Built-in magnet)
- Water resistant cylinder
- Made to Order
- Water resistant 2 colour indication solid state switch

Option	Seal
R	Seal NBR (Nitril rubber)
V	Seal FKM (Fluoro rubber)

This is ideal for use in a machine tool environment exposed to coolant. It is also well suited for use in areas in which water splashes, such as food processing equipment or car washers.



Specifications

Action	Double acting Single rod
Bore size (mm)	$\varnothing 20, \varnothing 25, \varnothing 32, \varnothing 40, \varnothing 50, \varnothing 63, \varnothing 80, \varnothing 100$
Cushion	None
Auto switch mounting	Rail mounting (D-F7BAL)
Made to Order	Piston rod, Rod end nut: Stainless steel (—XC6)

* Specifications except mentioned above are same as standard basic.

Series CDQ2

Auto Switch Specifications

Refer to p.5.3-2 for details of auto switch.



Minimum Strokes for Auto Switch Mounting

(mm)

Number of auto switches	D-F7□V D-J79C D-F9□V	D-A7□ D-A80 D-A73C D-A80C D-A9□V	D-F7□WV D-F9□WV	D-A7□H D-A80H D-F7□ D-J79 D-F9B D-F9P D-F9□W	D-A79W	D-F7□W D-J79W D-F7BAL D-F79F D-F9BAL	D-F7LF	D-A9□ D-F9N
1pc.	5	5	10	15	15	20	25	10
2pcs.	5	10	15	15	20	20	25	10

Applicable Auto Switch

Style	Auto switch model	Electrical entry (Function)	Page
Reed switch	D-A7□/A80	Grommet (Perpendicular)	5.3-14
	D-A7□H/A80H	Grommet (In-line)	5.3-15
	D-A73C/A80C	Connector	5.3-16
	D-A79W	Grommet (2 colour, Perpendicular)	5.3-26
	D-A9□	Grommet (In-line)	5.3-19
	D-A9□V	Grommet (Perpendicular)	5.3-20
Solid state switch	D-F7□/J79	Grommet (In-line)	5.3-34
	D-F7□V	Grommet (Perpendicular)	5.3-35
	D-J79C	Connector	5.3-36
	D-F7□W/J79W	Grommet (2 colour, In-line)	5.3-44
	D-F7□WV	Grommet (2 colour, Perpendicular)	5.3-45
	D-F7BAL	Grommet (2 colour, Water resistant, In-line)	5.3-57
	D-F79F	Grommet (2 colour, With diagnosis output, In-line)	5.3-53
	D-F9BAL	Grommet (2 colour, Water resistant, In-line)	5.3-67
	D-F7NTL	Grommet (With timer, In-line)	5.3-60
	D-F9□	Grommet (In-line)	5.3-39
	D-F9□V	Grommet (Perpendicular)	5.3-39
	D-F9□W	Grommet (2 colour, In-line)	5.3-66
	D-F9□WV	Grommet (2 colour, Perpendicular)	5.3-66
	D-F7LF	Grommet (2 colour, Latch with diagnostic output, In-line)	5.3-52

⚠ Precautions

Be sure to read before handling.
Refer to p.0-39 to 0-43 for common precautions when auto switch is used.

Weight

Unit: g

Bore (mm)	Cylinder stroke (mm)											
	5	10	15	20	25	30	35	40	45	50	75	100
12	47	54	60	67	74	80	-	-	-	-	-	-
16	73	82	92	101	110	119	-	-	-	-	-	-
20	109	122	136	150	164	178	191	205	219	233	-	-
25	144	161	178	195	211	228	245	262	278	295	-	-
32	190	211	232	252	273	294	315	335	356	377	482	587
40	282	305	328	351	375	398	421	444	467	490	610	730
50	-	487	523	559	595	632	668	704	740	777	965	1153
63	-	696	737	778	819	860	901	941	982	1023	1235	1446
80	-	1258	1325	1393	1461	1529	1597	1665	1732	1800	2135	2469
100	-	2118	2209	2299	2390	2481	2572	2662	2753	2844	3304	3764

Weight/Auto Switch Mounting Bracket

Part No.	Bore size	Weight (g)
BQ-1	ø12 to ø25	1.5
BQ-2	ø32 to ø100	1.5

Refer to p.5.3-75 for auto switch weight.

Option Weights

Unit: g

Bore size (mm)	12	16	20	25	32	40	50	63	80	100
Both ends tapped	1	1	3	3	6	6	6	19	45	45
Rod end male thread	Male thread	1.5	3	6	12	26	27	53	53	120
	Nut	1	2	4	8	17	17	32	32	49
Rear boss mount	0.7	1.3	2	3	5	7	13	25	45	96
With rubber bumper	0	-1	-2	-3	-3	-7	-9	-18	-31	-56
With One-touch fitting	-	-	-	-	12	12	21	21	-	-
Foot (including bolt)	49	62	147	169	143	155	243	324	696	1062
Front flange (including bolt)	54	67	131	153	180	214	373	559	1056	1365
Rear flange (including bolt)	52	63	124	144	165	198	348	534	1017	1309
Double clevis (including pin, snap ring, bolt)	29	35	78	114	151	196	393	554	1109	1887

Calculation example: CDQ2D32-20DCM

- Cylinder weight: CDQ2B32-20D 252g
 - Option weight: Both ends tapped 6g
 - Rod end male thread 43g
 - With rubber bumper -3g
 - Double clevis 151g
- 449g

If auto switches are to be installed, the weight that corresponds to the number of auto switches and mounting brackets to be used must be added.

Compact Cylinder/Standard: Double Acting Single Rod Series **CDQ2**

Construction

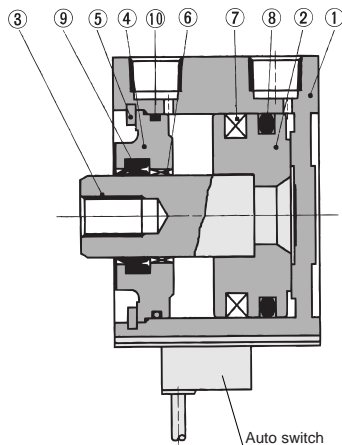

Components Parts

No.	Description	Material	Note
①	Cylinder tube	Aluminum alloy	Hard anodized
②	Piston	Aluminum alloy	Chromated
③	Piston rod	Stainless steel	ø12 to ø25
		Carbon steel	ø32 to ø100, Hard chrome plated
④	Collar	Aluminum bearing alloy	ø32 to ø40, Anodized
		Aluminum alloy casting	ø50 to ø100, Chromated, plated
⑤	Snap ring	Carbon tool steel	Phosphate coating
⑥	Bushing	Lead bronze casting	For ø50 or larger
⑦	Magnet	—	—
⑧	Piston seal	NBR	—
⑨	Rod seal	NBR	—
⑩	Gasket	NBR	—

Replacement Parts: Seal Kits

Series	Bore size (mm)	Kit No.	Contents
Pneumatic	12	CQ2B12-PS	Kits include items ⑧, ⑨ and ⑩ from the table above.
	16	CQ2B16-PS	
	20	CQ2B20-PS	
	25	CQ2B25-PS	
	32	CQ2B32-PS	
	40	CQ2B40-PS	
	50	CQ2B50-PS	
	63	CQ2B63-PS	
	80	CQ2B80-PS	
100	CQ2B100-PS		

Replacement Parts: Seal Kits

Series	Bore size (mm)	Kit No.	Contents
Air-hydro	20	CQ2BH20-PS	Kits include items ⑧, ⑨ and ⑩ from the table above.
	25	CQ2BH25-PS	
	32	CQ2BH32-PS	
	40	CQ2BH40-PS	
	50	CQ2BH50-PS	
	63	CQ2BH63-PS	
	80	CQ2BH80-PS	
	100	CQ2BH100-PS	

*Seal kits consist of items ⑧, ⑨ and ⑩ contained in one kit and can be ordered using the order number for each respective tube bore size.

Mounting Bolt for CDQ2 with Auto Switch

Special long bolt for through hole mounting is available as option.

How to Order: Specify the required bolts.

Example) Bolt M3 X 35ℓ 2pcs.

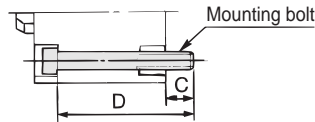

Model	C	D	Mounting bolt
CDQ2B12-5D	5.5	35	M3 X 35ℓ
-10D		40	X 40ℓ
-15D		45	X 45ℓ
-20D		50	X 50ℓ
-25D		55	X 55ℓ
-30D		65	X 60ℓ
CDQ2B16-5D	8	40	M3 X 40ℓ
-10D		45	X 45ℓ
-15D		50	X 50ℓ
-20D		55	X 55ℓ
-25D		60	X 60ℓ
-30D		65	X 65ℓ
CDQ2B20-5D	10.5	40	M5 X 40ℓ
-10D		45	X 45ℓ
-15D		50	X 50ℓ
-20D		55	X 55ℓ
-25D		60	X 60ℓ
-30D		65	X 65ℓ
-35D		70	X 70ℓ
-40D		75	X 75ℓ
-45D		80	X 80ℓ
-50D	85	X 85ℓ	
CDQ2B25-5D	9.5	40	M5 X 40ℓ
-10D		45	X 45ℓ
-15D		50	X 50ℓ
-20D		55	X 55ℓ
-25D		60	X 60ℓ
-30D		65	X 65ℓ
-35D		70	X 70ℓ
-40D		75	X 75ℓ
-45D		80	X 80ℓ
-50D		85	X 85ℓ

Model	C	D	Mounting bolt
CDQ2B32-5D	9	40	M5 X 40ℓ
-10D		45	X 45ℓ
-15D		50	X 50ℓ
-20D		55	X 55ℓ
-25D		60	X 60ℓ
-30D		65	X 65ℓ
-35D		70	X 70ℓ
-40D		75	X 75ℓ
-45D		80	X 80ℓ
-50D		85	X 85ℓ
CDQ2B40-5D	7.5	45	M5 X 45ℓ
-10D		50	X 50ℓ
-15D		55	X 55ℓ
-20D		60	X 60ℓ
-25D		65	X 65ℓ
-30D		70	X 70ℓ
-35D		75	X 75ℓ
-40D		80	X 80ℓ
-45D		85	X 85ℓ
-50D		90	X 90ℓ
CDQ2B50-10D	12.5	55	M6 X 55ℓ
-15D		60	X 60ℓ
-20D		65	X 65ℓ
-25D		70	X 70ℓ
-30D		75	X 75ℓ
-35D		80	X 80ℓ
-40D		85	X 85ℓ
-45D		90	X 90ℓ
-50D		95	X 95ℓ
-75D		120	X 120ℓ
-100D	145	X 145ℓ	

Model	C	D	Mounting bolt
CDQ2B63-10D	14.5	60	M8 X 60ℓ
-15D		65	X 65ℓ
-20D		70	X 70ℓ
-25D		75	X 75ℓ
-30D		80	X 80ℓ
-35D		85	X 85ℓ
-40D		90	X 90ℓ
-45D		95	X 95ℓ
-50D		100	X 100ℓ
-75D		125	X 125ℓ
CDQ2B80-10D	15	65	M10 X 65ℓ
-15D		70	X 70ℓ
-20D		75	X 75ℓ
-25D		80	X 80ℓ
-30D		85	X 85ℓ
-35D		90	X 90ℓ
-40D		95	X 95ℓ
-45D		100	X 100ℓ
-50D		105	X 105ℓ
-75D		130	X 130ℓ
CDQ2B100-10D	15.5	75	M10 X 75ℓ
-15D		80	X 80ℓ
-20D		85	X 85ℓ
-25D		90	X 90ℓ
-30D		95	X 95ℓ
-35D		100	X 100ℓ
-40D		105	X 105ℓ
-45D		110	X 110ℓ
-50D		115	X 115ℓ
-75D		140	X 140ℓ
-100D	165	X 165ℓ	

CUJ

CU

CQS

CQ2

RQ

MU

Series CQ2

ø12 to ø25

Both ends tapped: CQ2A

Standard (Through-hole)/CQ2B

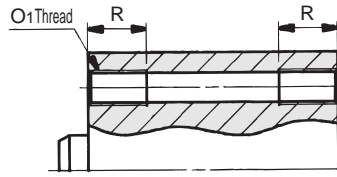

Both ends tapped (mm)

Bore size (mm)	O1	R
12	M4 X 0.7	7
16	M4 X 0.7	7
20	M6 X 1.0	10
25	M6 X 1.0	10

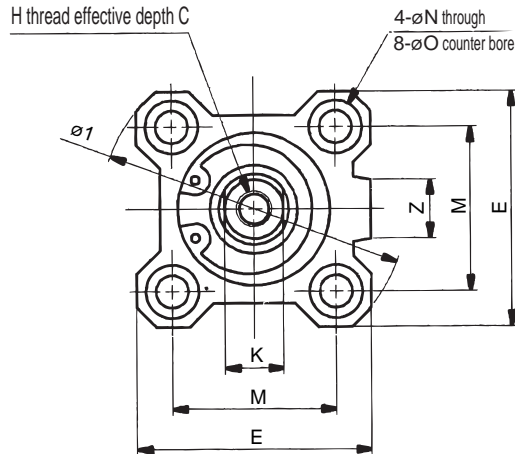
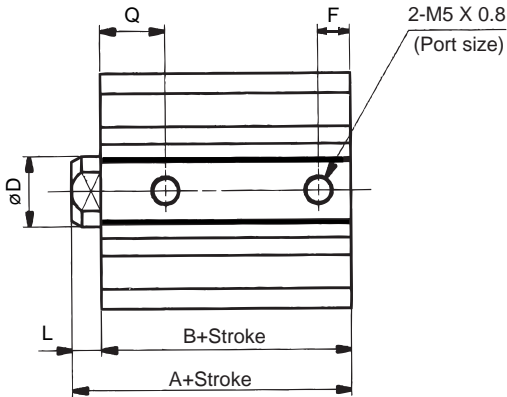

Rear boss mount

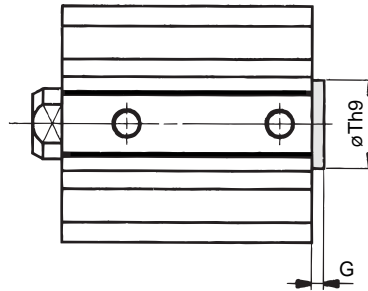

Rear boss mount (mm)

Bore (mm)	G	Th9
12	1.5	15 ⁰ _{-0.043}
16	1.5	20 ⁰ _{-0.052}
20	2	13 ⁰ _{-0.043}
25	2	15 ⁰ _{-0.043}

Note) Rod side with guide boss:
Option (Specify -XC36 at end of model no.)

Rod end male thread

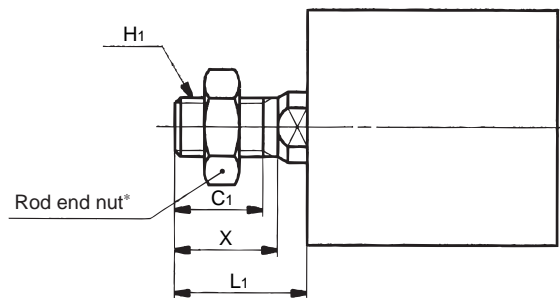

Rod end male thread (mm)

Bore (mm)	C1	X	H1	L1
12	9	10.5	M5 X 0.8	14
16	10	12	M6 X 1.0	15.5
20	12	14	M8 X 1.25	18.5
25	15	17.5	M10 X 1.25	22.5

Standard

Bore (mm)	Stroke range (mm)	A	B	C	D	E	F	H	I	K	L	M	N	O	Q	Z
12	5 to 30	20.5	17	6	6	25	5	M3 X 0.5	32	5	3.5	15.5	3.5	6.5 Depth 3.5	7.5	—
16	5 to 30	22	18.5	8	8	29	5.5	M4 X 0.7	38	6	3.5	20	3.5	6.5 Depth 3.5	8	10
20	5 to 50	24	19.5	7	10	36	5.5	M5 X 0.8	47	8	4.5	25.5	5.5	9 Depth 7	9	10
25	5 to 50	27.5	22.5	12	12	40	5.5	M6 X 1.0	52	10	5	28	5.5	9 Depth 7	11	10

Note) Dimensions of model with rubber bumper are same as mentioned above.

*Refer to p.2.3-18 for rod edge nut and optional bracket.



Refer to p.2.3-3 for calculation of cylinder length with intermediate stroke.

Compact Cylinder/Standard: Double Acting Single Rod **Series CQ2**

Foot/CQ2L

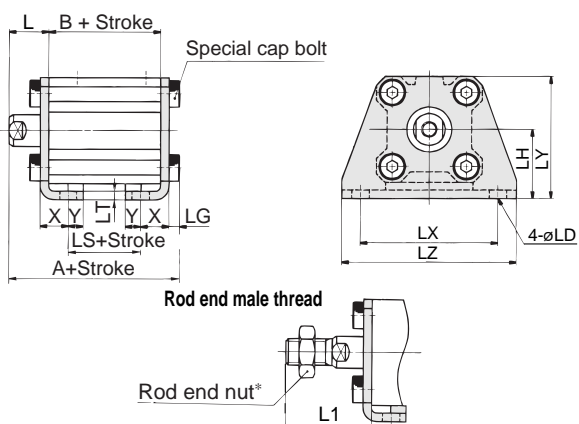

Foot

Bore (mm)	Stroke range (mm)	A	B	L	L1	LD	LG	LH	LS	LT	LX	LY	LZ	X	Y
12	5 to 30	35.3	17	13.5	24	4.5	2.8	17	5	2	34	29.5	44	8	4.5
16	5 to 30	36.8	18.5	13.5	25.5	4.5	2.8	19	6.5	2	38	33.5	48	8	5
20	5 to 50	41.2	19.5	14.5	28.5	6.6	4	24	7.5	3.2	48	42	62	9.2	5.8
25	5 to 50	44.7	22.5	15	32.5	6.6	4	26	7.5	3.2	52	46	66	10.7	5.8

Front flange/CQ2F

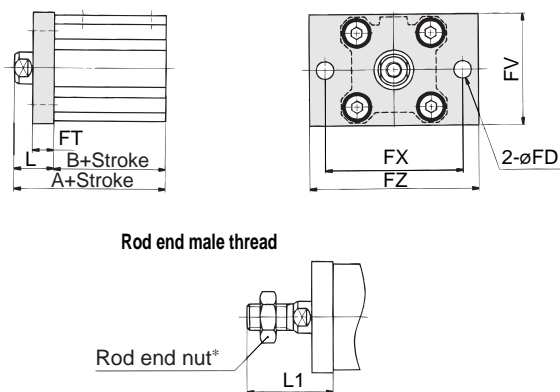

Front flange

Bore (mm)	Stroke range (mm)	A	B	FD	FT	FV	FX	FZ	L	L1
12	5 to 30	30.5	17	4.5	5.5	25	45	55	13.5	24
16	5 to 30	32	18.5	4.5	5.5	30	45	55	13.5	25.5
20	5 to 50	34	19.5	6.6	8	39	48	60	14.5	28.5
25	5 to 50	37.5	22.5	6.6	8	42	52	64	15	32.5

Rear flange/CQ2G

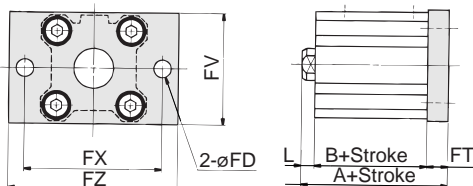

Rear flange

Bore (mm)	Stroke range (mm)	A	L	L1
12	5 to 30	26	3.5	14
16	5 to 30	27.5	3.5	15.5
20	5 to 50	32	4.5	18.5
25	5 to 50	35.5	5	22.5

*All dimensions except "A", "L" and "L1" are same as rod side flange type.

Rod end male thread

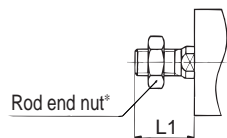

Double clevis/CQ2D

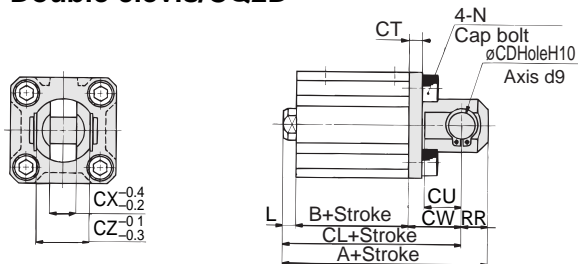

Double clevis

Bore (mm)	Stroke (mm)	A	B	CD	CL	CT	CU	CW	CX	CZ	L	L1	N	RR
12	5 to 30	40.5	17	5	34.5	4	7	14	5	10	3.5	14	M4 X 0.7	6
16	5 to 30	43	18.5	5	37	4	10	15	6.5	12	3.5	15.5	M4 X 0.7	6
20	5 to 50	51	19.5	8	42	5	12	18	8	16	4.5	18.5	M6 X 1.0	9
25	5 to 50	57.5	22.5	10	47.5	5	14	20	10	20	5	22.5	M6 X 1.0	10

* Refer to p.2.3-18 for rod end nut and optional brackets.
** Clevis pin and snap ring are contained.

Rod end male thread

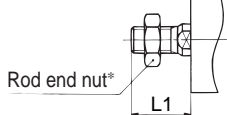

- CJ
- CU
- CQS
- CQ2**
- RQ
- MU

Series CDQ2

ø12 to ø25 With Auto Switch

Standard (Through-hole)/CDQ2B

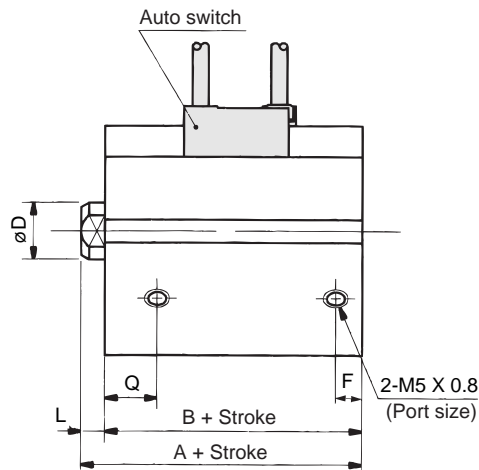

Both ends tapped: CDQ2A

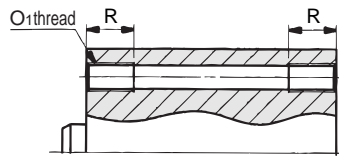

Both ends tapped (mm)

Bore (mm)	O ₁	R
12	M4 X 0.7	7
16	M4 X 0.7	7
20	M6 X 1.0	10
25	M6 X 1.0	10

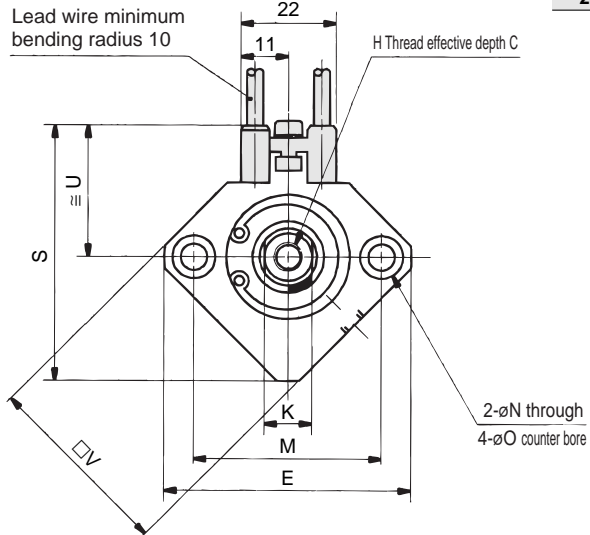

Rear boss mount

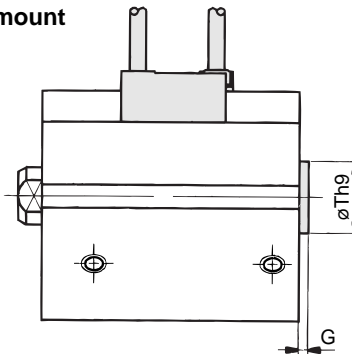

Rear boss mount (mm)

Bore (mm)	G	Th9
12	1.5	15 ⁰ _{-0.043}
16	1.5	20 ⁰ _{-0.052}
20	2	13 ⁰ _{-0.043}
25	2	15 ⁰ _{-0.043}

Note 1) Rod side with guide boss: Option (Specify "-XC36" at end of model no.)

Rod end male thread

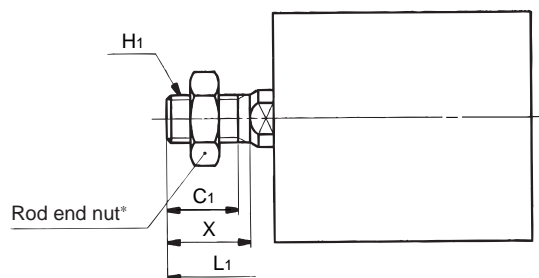

Rod end male thread (mm)

Bore (mm)	C ₁	X	H ₁	L ₁
12	9	10.5	M5 X 0.8	14
16	10	12	M6 X 1.0	15.5
20	12	14	M8 X 1.25	18.5
25	15	17.5	M10 X 1.25	22.5

Auto switch shown above is D-A73 and D-A80.

Refer to p.2.3-20 for auto switch mounting position and mounting height.

Standard

Bore (mm)	Stroke range (mm)	A	B	C	D	E	F	H	K	L	M	N	O	Q	S	U	V
12	5 to 30	31.5	28	6	6	32	6.5	M3 X 0.5	5	3.5	22	3.5	6.5 Depth 3.5	11	35.5	19.5	25
16	5 to 30	34	30.5	8	8	38	5.5	M4 X 0.7	6	3.5	28	3.5	6.5 Depth 3.5	10	41.5	22.5	29
20	5 to 50	36	31.5	7	10	47	5.5	M5 X 0.8	8	4.5	36	5.5	9 Depth 7	10.5	48	24.5	36
25	5 to 50	37.5	32.5	12	12	52	5.5	M6 X 1.0	10	5	40	5.5	9 Depth 7	11	53.5	27.5	40



Note 2) Dimensions with rubber bumper are same as standard shown above.

*Refer to p.2.3-18 & 19 for rod end nut and optional brackets.

Note 3) Refer to p.2.3-3 for calculation of cylinder length with intermediate stroke.

Compact Cylinder/Standard: Double Acting Single Rod *Series CDQ2*

Foot /CDQ2L

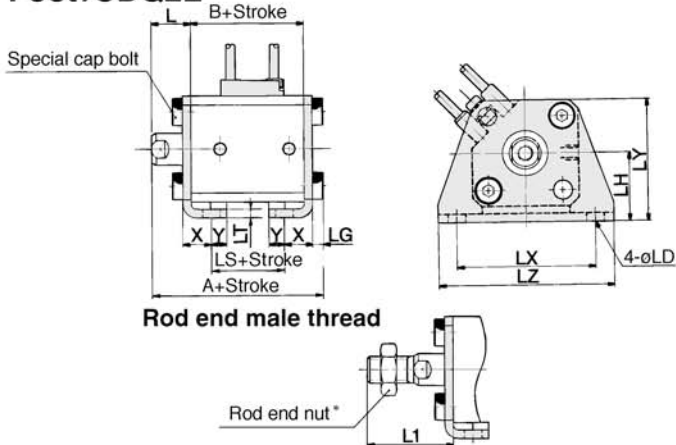

Foot

Bore (mm)	Stroke range (mm)	A	B	L	L1	LD	LG	LH	LS	LT	LX	LY	LZ	X	Y
12	5 to 30	46.3	28	13.5	24	4.5	2.8	17	16	2	34	29.5	44	8	4.5
16	5 to 30	48.8	30.5	13.5	25.5	4.5	2.8	19	18.5	2	38	33.5	48	8	5
20	5 to 50	53.2	31.5	14.5	28.5	6.6	4	24	19.5	3.2	48	42	62	9.2	5.8
25	5 to 50	54.7	32.5	15	32.5	6.6	4	26	17.5	3.2	52	46	66	10.7	5.8

Front flange/CDQ2F

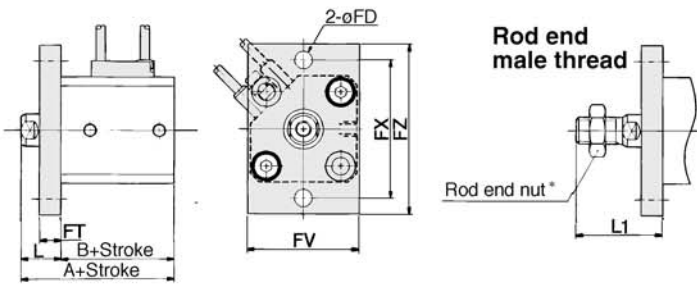

Front flange

Bore (mm)	Stroke range (mm)	A	B	FD	FT	FV	FX	FZ	L	L1
12	5 to 30	41.5	28	4.5	5.5	25	45	55	13.5	24
16	5 to 30	44	30.5	4.5	5.5	30	45	55	13.5	25.5
20	5 to 50	46	31.5	6.6	8	39	48	60	14.5	28.5
25	5 to 50	47.5	32.5	6.6	8	42	52	64	15	32.5

Rear flange/CDQ2G

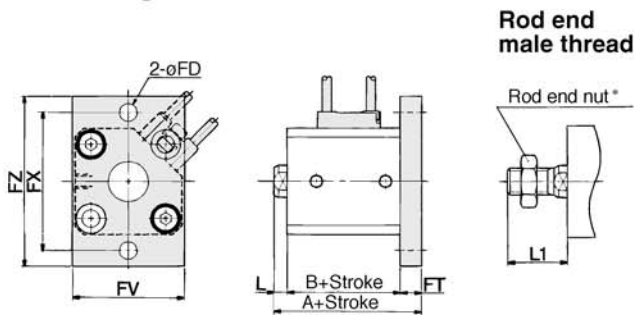

Rear flange

Bore (mm)	Stroke range (mm)	A	L	L1
12	5 to 30	37	3.5	14
16	5 to 30	39.5	3.5	15.5
20	5 to 50	44	4.5	18.5
25	5 to 50	45.5	5	22.5

*All dimensions except "A", "L" and "L1" are same as Rod side flange type.

Double clevis/CDQ2D

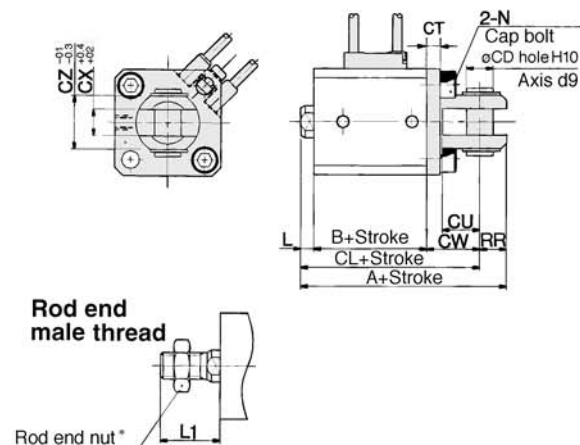

Double clevis

Bore (mm)	Stroke range (mm)	A	B	CD	CL	CT	CU	CW	CX	CZ	L	L1	N	RR
12	5 to 30	51.5	28	5	45.5	4	7	14	5	10	3.5	14	M4 X 0.7	6
16	5 to 30	55	30.5	5	49	4	10	15	6.5	12	3.5	15.5	M4 X 0.7	6
20	5 to 50	63	31.5	8	54	5	12	18	8	16	4.5	18.5	M6 X 1.0	9
25	5 to 50	67.5	32.5	10	57.5	5	14	20	10	20	5	22.5	M6 X 1.0	10

*Refer to p.2.3-18 & 19 for rod end nut and optional brackets.

**Clevis pin and snap ring are contained.

CUJ

CU

CQS

CQ2

RQ

MU

Series CQ2/CDQ2

ø32 to ø50 With Auto Switch

For those without auto switches, refer to the dimension chart because their A, B, F, P and Q dimensions will differ.

Standard (Through-hole)/CQ2B, CDQ2B

Both ends tapped: CDQ2A

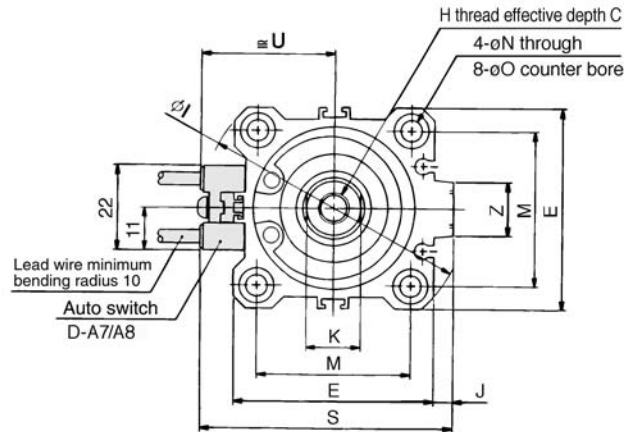
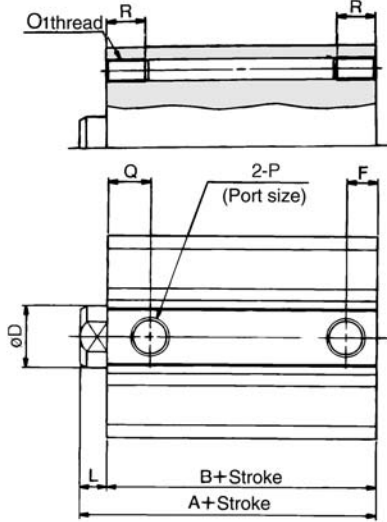

Both ends tapped (mm)

Bore (mm)	O ₁	R
32	M6 X 1.0	10
40	M6 X 1.0	10
50	M8 X 1.25	14

Rear boss mount

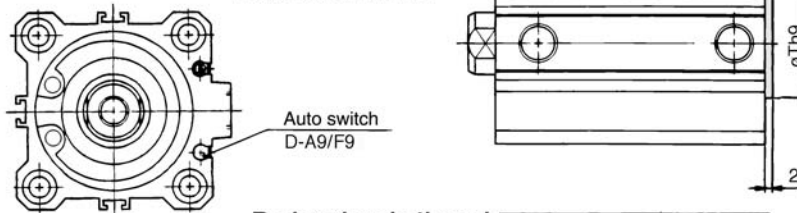

Rear boss mount (mm)

Bore (mm)	Th9
32	21 ⁰ _{-0.052}
40	28 ⁰ _{-0.052}
50	35 ⁰ _{-0.062}

Rod end male thread

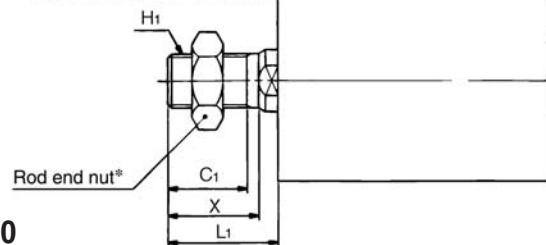

Rod end male thread (mm)

Bore (mm)	C ₁	X	H ₁	L ₁
32	20.5	23.5	M14 X 1.5	28.5
40	20.5	23.5	M14 X 1.5	28.5
50	26	28.5	M18 X 1.5	33.5

Built-in One-touch fitting/ø32 to ø50

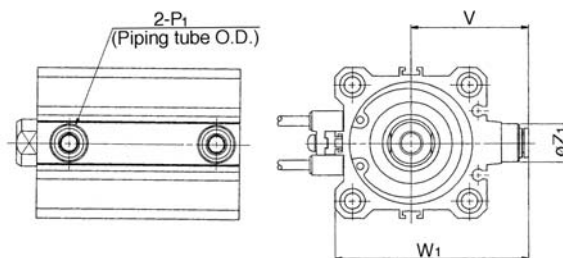

Built-in One-touch fitting (mm)

Bore (mm)	Z ₁	P ₁	V	W ₁
32	13	6	36.5	59
40	13	6	40.5	66
50	16	8	50	82

Standard Auto switch shown above is D-A73 and D-A80. Refer to p.2.3-20 for auto switch mounting position and mounting height.

Bore (mm)	Stroke range (mm)	Without auto switch					With auto switch					C	D	E	H	I	J	K	L	M
		A	B	F	P	Q	A	B	F	P	Q									
32	5	30	23	5.5	M5 X 0.8	11.5	40	33	7.5	1/8	10.5	13	16	45	M8 X 1.25	60	4.5	14	7	34
	10 to 50	40	33	7.5	1/8	10.5														
40	5 to 50	36.5	29.5	8	1/8	11	46.5	39.5	8	1/8	11	13	16	52	M8 X 1.25	69	5	14	7	40
	75, 100	46.5	39.5																	
50	10 to 50	38.5	30.5	10.5	1/4	10.5	48.5	40.5	10.5	1/4	10.5	15	20	64	M10 X 1.5	86	7	17	8	50
	75, 100	48.5	40.5																	

Bore (mm)	N	O	S	U	Z
32	5.5	9 Depth 7	58.5	31.5	14
40	5.5	9 Depth 7	66	35	14
50	6.6	11 Depth 8	80	41	19



Note 1) Dimensions of style with rubber bumper are same as standard shown above.

* Refer to p.2.3-18 & 19 for rod end nut and optional bracket.

Note 2) Because the method for calculating the longitudinal dimension of the intermediate stroke varies between the spacer-installed style and the special body (-X10) style, refer to p.2.3-3 for details.

Compact Cylinder/Standard: Double Acting Single Rod **Series CQ2**

Foot/CQ2L, CDQ2L

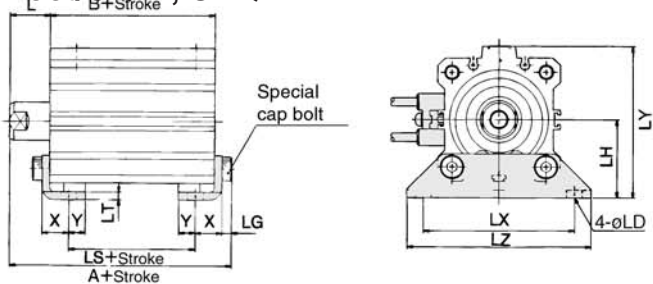

Rod end male thread

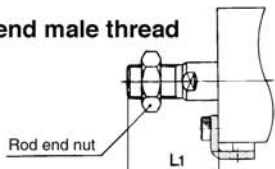

Front flange/C□Q2F

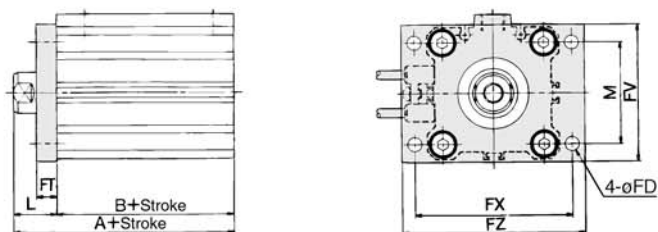

Rod end male thread

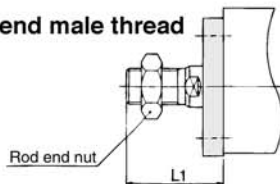

Rear flange/CQ2G, CDQ2G

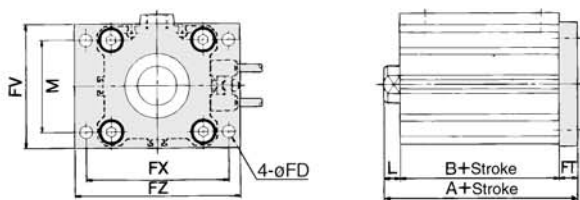

Rod end male thread

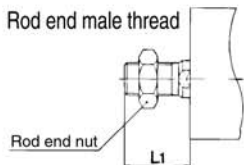

Applicable to rear flange mounting and double clevis mounting.

Double clevis/CQ2D, CDQ2D

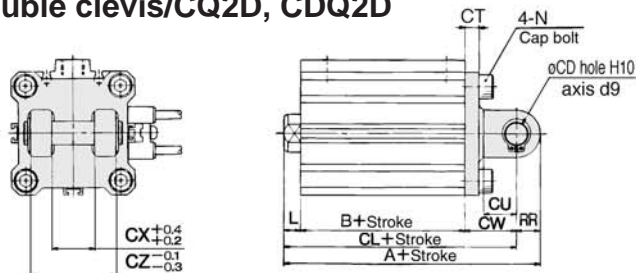

Foot

Bore (mm)	Stroke range (mm)	W/o auto switch			With auto switch			L	L1	LD	LG	LH	LT	LX	LY
		A	B	LS	A	B	LS								
		32	5 to 50 75, 100	47.2 57.2	23 33	7 17	57.2 63.7								
40	5 to 50 75, 100	53.7 63.7	29.5 39.5	13.5 23.5	63.7 70.2	39.5 45.5	23.5 29.5	17	38.5	6.6	4	33	3.2	64	64
50	10 to 50 75, 100	56.7 66.7	30.5 40.5	7.5 17.5	66.7 73.2	40.5 46.5	17.5 23.5	18	43.5	9	5	39	3.2	79	78

(mm)

Bore (mm)	LZ	X	Y
32	71	11.2	5.8
40	78	11.2	7
50	95	14.7	8

Front flange

Bore (mm)	Stroke range (mm)	Without auto switch		With auto switch		FD	FT	FV	FX	FZ	L	L1	M
		A	B	A	B								
		32	5 to 50 75, 100	40 50	23 33								
40	5 to 50 75, 100	46.5 56.5	29.5 39.5	56.5 63.0	39.5 45.5	5.5 6.6	8 9	54 60	62 68	72 78	17	38.5	40
50	10 to 50 75, 100	48.5 58.5	30.5 40.5	58.5 65.0	40.5 46.5	6.6 7.7	9 10	67 73	76 82	89 95	18	43.5	50

(mm)

Rear flange

Bore (mm)	Stroke range (mm)	Without auto switch		With auto switch		L	L1
		A	A	A	A		
		32	5 to 50 75, 100	38 48	48		
40	5 to 50 75, 100	44.5 54.5	54.5	7	28.5		
50	10 to 50 75, 100	47.5 57.5	57.5	8	33.5		

(*All dimensions except "A", "L" and "L1" are same as rod side flange mounting type.)

Double clevis

Bore (mm)	Stroke range (mm)	W/o auto switch			With auto switch			CD	CT	CU	CW	CX	CZ	L	L1
		A	B	CL	A	B	CL								
		32	5 to 50 75, 100	60 70	23 33	50 60	70 76.5								
40	5 to 50 75, 100	68.5 78.5	29.5 39.5	58.5 68.5	78.5 84.5	39.5 45.5	68.5 74.5	10	6	14	22	18	36	7	28.5
50	10 to 50 75, 100	80.5 90.5	30.5 40.5	66.5 76.5	90.5 96.5	40.5 46.5	76.5 82.5	14	7	20	28	22	44	8	33.5

(mm)

Bore (mm)	N	RR
32	M6 X 1.0	10
40	M6 X 1.0	10
50	M8 X 1.25	14

* Refer to p.2.3-18 & 19 for rod end nut and optional brackets.

** Clevis pin and snap ring are contained.

* The diagram shows with an auto switch, which may be deleted if unnecessary.

CUJ

CU

CQS

CQ2

RQ

MU

Series CQ2/CDQ2

ø63 to ø100 With Auto Switch

For those without auto switches, refer to the dimension chart because their A, B and Q dimensions will differ.

Standard (Through-hole)

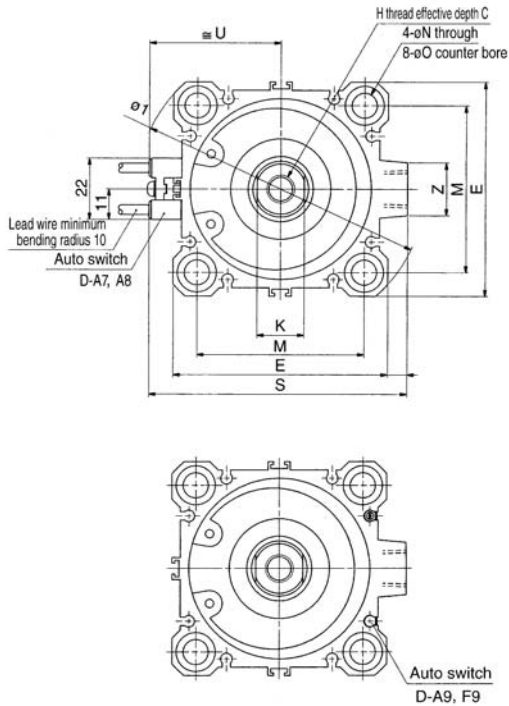

Standard (Through-hole)

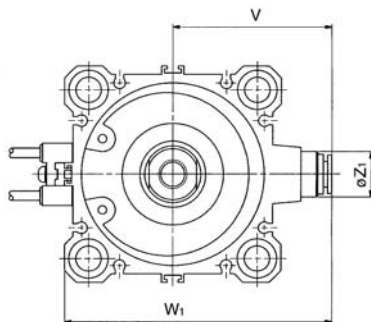

Both ends tapped: CQ2A, CDQ2A Both ends tapped (mm)

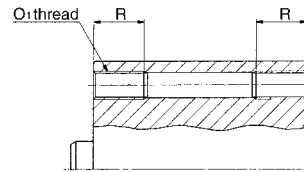

Bore (mm)	O1	R
63	M10 X 1.5	18
80	M12 X 1.75	22
100	M12 X 1.75	22

Rear boss mount

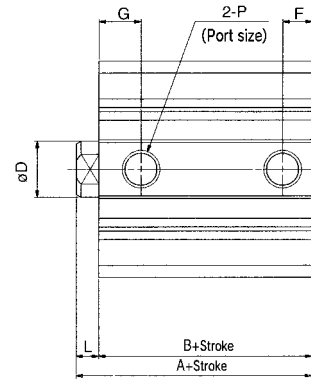

Rear boss mount (mm)

Bore (mm)	Th9
63	35 ⁰ _{-0.062}
80	43 ⁰ _{-0.062}
100	59 ⁰ _{-0.074}

Note 1) Rod side with guide boss:
Option (Specify "XC36" at end of model no.)

Rod end male thread

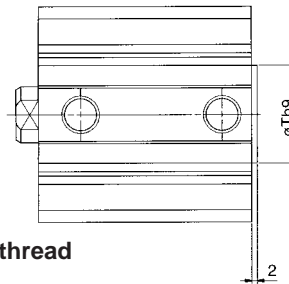

Rod end male thread (mm)

Bore (mm)	C1	X	H1	L1
63	26	28.5	M18 X 1.5	33.5
80	32.5	35.5	M22 X 1.5	43.5
100	32.5	35.5	M26 X 1.5	43.5

Built-in One-touch fitting (mm)

Bore (mm)	Z1	P1	V	W1
63	16	8	56.5	95

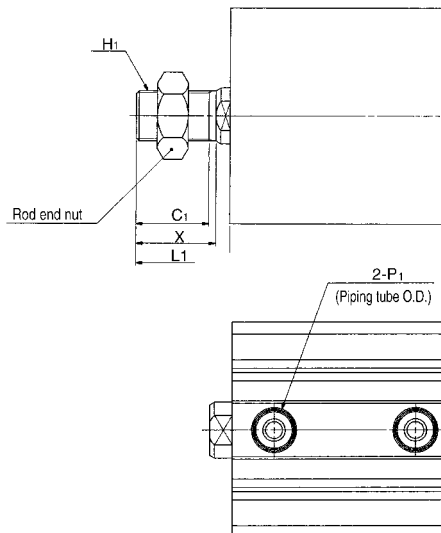

Standard Auto switch shown above is D-A73 and D-A80. Refer to p.2.3-20 for auto switch mounting position and mounting height. (mm)

Bore (mm)	Head side with guide boss (mm)	W/o auto switch		With auto switch		C	D	E	F	H	I	J	K	L	M	N	O	P	Q	S
		A	B	A	B															
63	10 to 50	44	36	54	46	15	20	77	10.5	M10 X 1.5	103	7	17	8	60	9	14 Depth 10.5	1/4	15	93
	75, 100	54	46																	
80	10 to 50	53.5	43.5	63.5	53.5	21	25	98	12.5	M16 X 2.0	132	6	22	10	77	11	17.5 Depth 13.5	3/8	16	112.5
	75, 100	63.5	53.5																	
100	10 to 50	65	53	75	63	27	30	117	13	M20 X 2.5	156	6.5	27	12	94	11	17.5 Depth 13.5	3/8	23	132.5
	75, 100	75	63																	

mm		
Bore (mm)	U	Z
63	47.5	19
80	57.5	26
100	67.5	26



Note 2) Dimensions of style with rubber bumper are same as standard shown above.
* Refer to p.2.3-18 & 19 for rod end nut and optional brackets.
Note 3) Refer to p.2.3-3 for calculation of cylinder length with intermediate stroke.

Compact Cylinder/Standard: Double Acting Single Rod *Series CDQ2*

Foot/CQ2L, CDQ2L

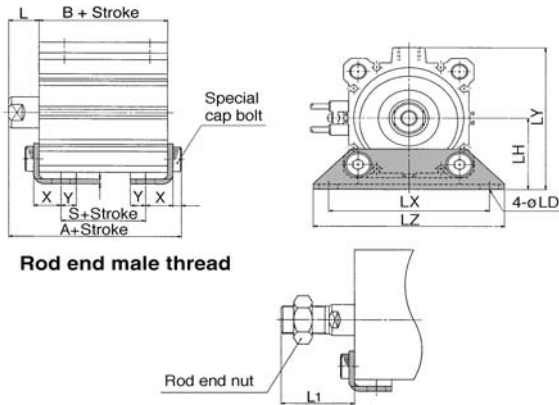

Rear flange/CQ2G, CDQ2G

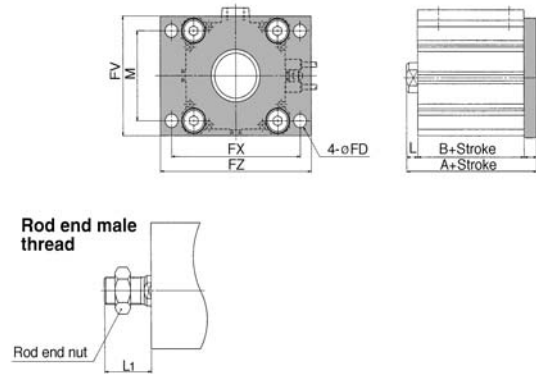

Front flange/CQ2F, CDQ2F

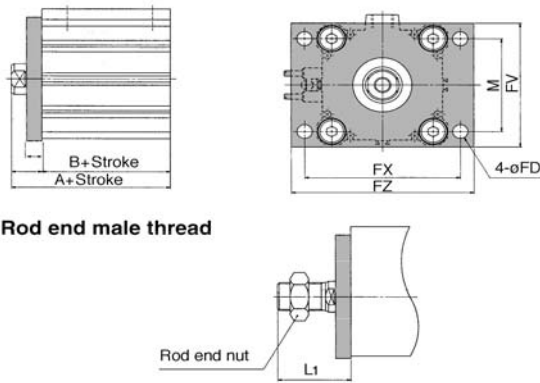

Double clevis/CQ2D, CDQ2D

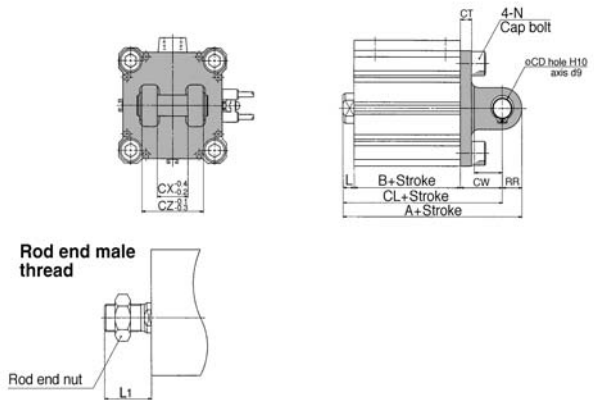

Foot (mm)

Bore (mm)	Stroke range (mm)	W/o auto switch		With auto switch		L	L1	LD	LG	LH	LS	LT	LX
		A	B	A	B								
63	10 to 50	62.2	36	72.2	46	18	43.5	11	5	46	20	3.2	95
	75, 100	72.2	46										
80	10 to 50	75	43.5	85	53.5	20	53.5	13	7	59	23.5	4.5	118
	75, 100	85	53.5										
100	10 to 50	88	53	98	63	22	53.5	13	7	71	29	6	137
	75, 100	98	63										

Bore (mm)	Stroke range (mm)	LY	LZ	X	Y
63	10 to 50	91.5	113	16.2	9
	75, 100				
80	10 to 50	114	140	19.5	11
	75, 100				
100	10 to 50	136	162	23	12.5
	75, 100				

Front flange (mm)

Bore (mm)	Stroke range (mm)	W/o auto switch		With auto switch		FD	FT	FV	FX	FZ	L	L1	M
		A	B	A	B								
63	10 to 50	54	36	64	46	9	9	80	92	108	18	43.5	60
	75, 100	64	46										
80	10 to 50	63.5	43.5	73.5	53.5	11	11	99	116	134	20	53.5	77
	75, 100	73.5	53.5										
100	10 to 50	75	53	85	63	11	11	117	136	154	22	53.5	94
	75, 100	85	63										

Rear flange (mm)

Bore (mm)	Stroke range (mm)	W/o auto switch		With auto switch		L	L1
		A	B	A	B		
63	10 to 50	53	36	63	46	8	33.5
	75, 100	63	46				
80	10 to 50	64.5	43.5	74.5	53.5	10	43.5
	75, 100	74.5	53.5				
100	10 to 50	76	53	86	63	12	43.5
	75, 100	86	63				

*All dimensions except "A", "L" and "L1" are same as rod side flange type.

Double clevis (mm)

Bore (mm)	Stroke range (mm)	W/o auto switch		With auto switch		CD	CL	CT	CU	CW	CX	CZ	L
		A	B	A	B								
63	10 to 50	88	36	98	46	14	84	8	20	30	22	44	8
	75, 100	98	46										
80	10 to 50	109.5	43.5	119.5	53.5	18	101.5	10	27	38	28	56	10
	75, 100	119.5	53.5										
100	10 to 50	132	53	142	63	22	120	13	31	45	32	64	12
	75, 100	142	63										

Bore (mm)	Stroke range (mm)	L1	N	RR
63	10 to 50	33.5	M10 X 1.5	14
	75, 100			
80	10 to 50	43.5	M12 X 1.75	18
	75, 100			
100	10 to 50	43.5	M12 X 1.75	22
	75, 100			

*Refer to p.2.3-18 & 19 for rod end nut and optional brackets.

*Clevis pin and snap ring are contained.

CUJ

CU

CQS

CQ2

RQ

MU

Series CQ2

Accessories

Single knuckle joint

I-G012, I-Z015A
I-G02, I-G03

I-G04, I-G05
I-G08, I-G10

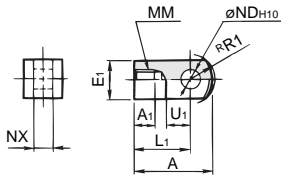

Material: Rolled steel

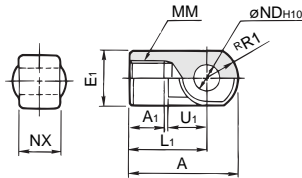

Material: Cast steel

(mm)

Part No.	Bore size (mm)	A	A ₁	E ₁	L ₁	MM	^R R ₁	U ₁	ND _{H10}	NX
I-G012	12	21.5	6	□10	16	M5 X 0.8	6.3	7	5 ^{+0.048} ₀	5 ^{-0.2} _{-0.4}
I-Z015A	16	32	8	□12	25	M6 X 1	8.1	14	5 ^{+0.048} ₀	6.4 ^{-0.1} _{-0.3}
I-G02	20	34	8.5	□16	25	M8 X 1.25	10.3	11.5	8 ^{+0.058} ₀	8 ^{-0.2} _{-0.4}
I-G03	25	41	10.5	□20	30	M10 X 1.25	12.8	14	10 ^{+0.058} ₀	10 ^{-0.2} _{-0.4}
I-G04	32, 40	42	14	∅22	30	M14 X 1.5	12	14	10 ^{+0.058} ₀	18 ^{-0.3} _{-0.5}
I-G05	50, 63	56	18	∅28	40	M18 X 1.5	16	20	14 ^{+0.070} ₀	22 ^{-0.3} _{-0.5}
I-G08	80	71	21	∅38	50	M22 X 1.5	21	27	18 ^{+0.070} ₀	28 ^{-0.3} _{-0.5}
I-G10	100	79	21	∅44	55	M26 X 1.5	24	31	22 ^{+0.084} ₀	32 ^{-0.3} _{-0.5}

Double knuckle joint

Y-G012, Y-Z015A
Y-G02, Y-G03

Y-G04, Y-G05
Y-G08, Y-G10

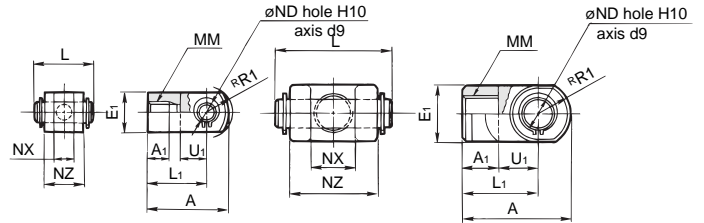

Material: Rolled steel

Material: Cast steel

(mm)

Part No.	Bore size (mm)	A	A ₁	E ₁	L ₁	MM	^R R ₁	U ₁	ND _{H10}	NX	NZ	L	Pin part No.
Y-G012	12	21.5	6	□10	16	M5 X 0.8	6.3	7	5 ^{+0.048} ₀	5 ^{-0.4} _{-0.2}	10	14.6	IY-G012
Y-Z015A	16	28	11	□12	21	M6 X 1	8.1	10	5 ^{+0.048} ₀	6.5 ^{-0.2} _{-0.4}	12	16.6	IY-J015
Y-G02	20	34	8.5	□16	25	M8 X 1.25	10.3	11.5	8 ^{+0.058} ₀	8 ^{-0.4} _{-0.2}	16	21	IY-G02
Y-G03	25	41	10.5	□20	30	M10 X 1.25	12.8	14	10 ^{+0.058} ₀	10 ^{-0.4} _{-0.2}	20	25.6	IY-G03
Y-G04	32, 40	42	16	∅22	30	M14 X 1.5	12	14	10 ^{+0.058} ₀	18 ^{-0.5} _{-0.3}	36	41.6	IY-G04
Y-G05	50, 63	56	20	∅28	40	M18 X 1.5	16	20	14 ^{+0.070} ₀	22 ^{-0.5} _{-0.3}	44	50.6	IY-G05
Y-G08	80	71	23	∅38	50	M22 X 1.5	21	27	18 ^{+0.070} ₀	28 ^{-0.5} _{-0.3}	56	64	IY-G08
Y-G10	100	79	24	∅44	55	M26 X 1.5	24	31	22 ^{+0.084} ₀	32 ^{-0.5} _{-0.3}	64	72	IY-G10

*Knuckle pin and snap ring are contained.

Knuckle pin (Common with double clevis pin)

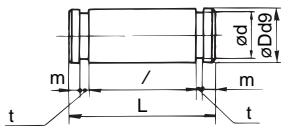

Material: Carbon steel (mm)

Part No.	Bore size (mm)	Dd ₉	L	d	/	m	t	Snap ring
IY-G012	12	5 ^{-0.030} _{-0.060}	14.6	4.8	10.2	1.5	0.7	For axis C shaped 5
IY-J015	16	5 ^{-0.030} _{-0.060}	16.6	4.8	12.2	1.5	0.7	For axis C shaped 5
IY-G02	20	8 ^{-0.040} _{-0.076}	21	7.6	16.2	1.5	0.9	For axis C shaped 8
IY-G03	25	10 ^{-0.040} _{-0.076}	25.6	9.6	20.2	1.55	1.15	For axis C shaped 10
IY-G04	32, 40	10 ^{-0.040} _{-0.076}	41.6	9.6	36.2	1.55	1.15	For axis C shaped 10
IY-G05	50, 63	14 ^{-0.050} _{-0.093}	50.6	13.4	44.2	2.05	1.15	For axis C shaped 14
IY-G08	80	18 ^{-0.050} _{-0.093}	64	17	56.2	2.55	1.35	For axis C shaped 18
IY-G10	100	22 ^{-0.065} _{-0.117}	72	21	64.2	2.55	1.35	For axis C shaped 22

Rod end nut

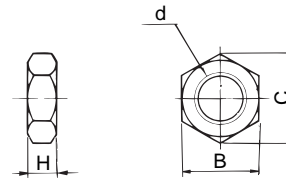

Material: Carbon steel (mm)

Part No.	Bore size (mm)	d	H	B	C
NTJ-015A	12	M5 X 0.8	4	8	9.2
NT-015A	16	M6 X 1	5	10	11.5
NT-02	20	M8 X 1.25	5	13	15.0
NT-03	25	M10 X 1.25	6	17	19.6
NT-04	32, 40	M14 X 1.5	8	22	25.4
NT-05	50, 63	M18 X 1.5	11	27	31.2
NT-08	80	M22 X 1.5	13	32	37.0
NT-10	100	M26 X 1.5	16	41	47.3

Compact Cylinder/Standard: Double Acting Single Rod **Series CQ2**

Joint for CQ2/ø32 to ø100

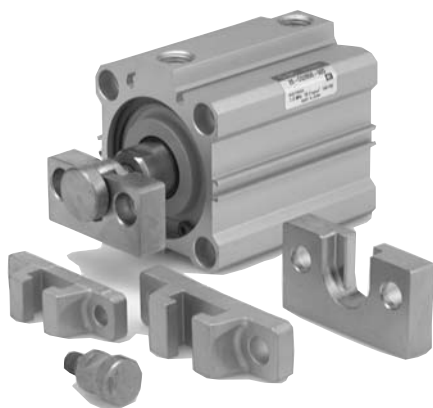

A type mounting bracket

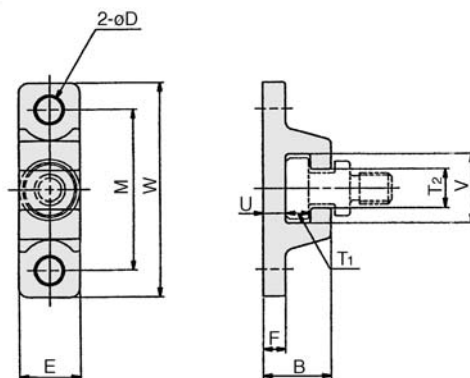

Joint/Mounting Bracket Part No. (A type, B type)

YA — **03**

• Mounting bracket

YA	A type mounting bracket
YB	B type mounting bracket
YU	Joint

• Applicable bore size

03	For ø32, ø40
05	For ø50, ø63
08	For ø80
10	For ø100

Allowable Eccentricity

Bore size	ø32	ø40	ø50	ø63	ø80	ø100
Eccentricity	±1			±1.5		
Play	0.5					

<How to Order>

- A joint is not included with the A or B type mounting brackets, and they must be ordered together.

(Example)

For bore size ø40

Part No.

• A type mounting bracket part No.YA-03

• Joint.....YU-03

Joint Part No.

Bore size (mm)	Joint part No.	Applicable mounting bracket		Weight (g)
		A bracket	B bracket	
ø32, 40	YU-03	YA-03	YB-03	25
ø50, 63	YU-05	YA-05	YB-05	40
ø80	YU-08	YA-08	YB-08	90
ø100	YU-10	YA-10	YB-10	160

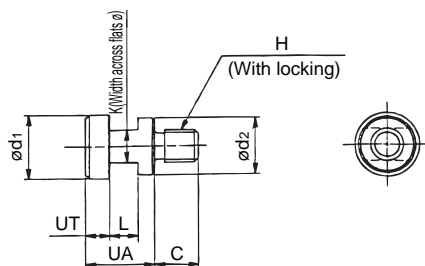

Part No.	Bore size (mm)	UA	C	d1	d2	H	K	L	UT	Weight (g)
YU-03	ø32, ø40	17	11	15.8	14	M8 X 1.25	8	7	6	25
YU-05	ø50, ø63	17	13	19.8	18	M10 X 1.5	10	7	6	40
YU-08	ø80	22	20	24.8	23	M16 X 2	13	9	8	90
YU-10	ø100	26	26	29.8	28	M20 X 2.5	14	11	10	160

Part No.	Bore size (mm)	B	øD	E	F	M	T1	T2
YA-03	32, 40	18	6.8	16	6	42	6.5	10
YA-05	50, 63	20	9	20	8	50	6.5	12
YA-08	80	26	11	25	10	62	8.5	16
YA-10	100	31	14	30	12	76	10.5	18

Part No.	Bore size (mm)	K	L	M	Weight (g)
YA-03	32, 40	6	18	56	55
YA-05	50, 63	8	22	67	100
YA-08	80	10	28	83	195
YA-10	100	12	36	100	340

B type mounting bracket

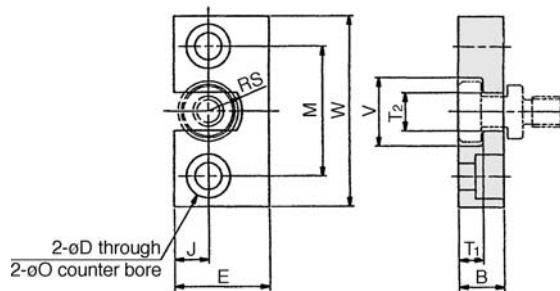

Part No.	Bore size (mm)	B	øD	E	J	M	O
YB-03	32, 40	12	7	25	9	34	11.5 Depth 7.5
YB-05	50, 63	12	9	32	11	42	14.5 Depth 8.5
YB-08	80	16	11	38	13	52	18 Depth 12
YB-10	100	19	14	50	17	62	21 Depth 14

Part No.	Bore size (mm)	T1	T2	V	W	S	Weight (g)
YB-03	32, 40	6.5	10	18	50	11	80
YB-05	50, 63	6.5	12	22	60	14	120
YB-08	80	8.5	16	28	75	18	230
YB-10	100	10.5	18	36	90		455

CUJ

CU

CQS

CQ2

RQ

MU

Series CDQ2

Auto Switch Mounting Position (at Stroke End) and Mounting Height

D-A7□
D-A80

ø12 to ø25

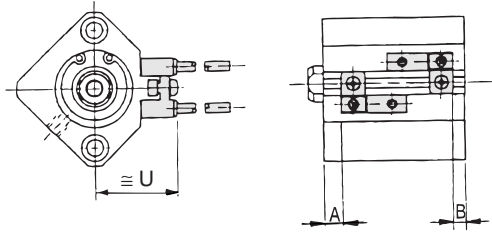

ø32 to ø100

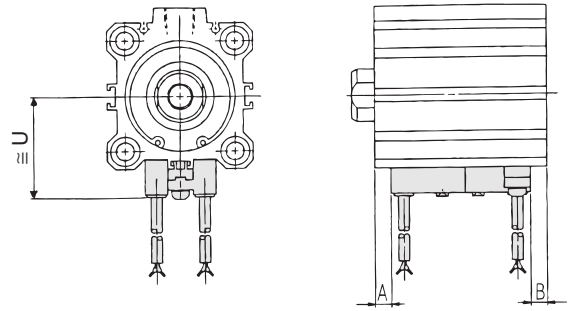

D-A7□H
D-A80H
D-F7□
D-J79
D-F7□W
D-J79W
D-F7□F
D-F7NT
D-F7BAL

ø12 to ø25

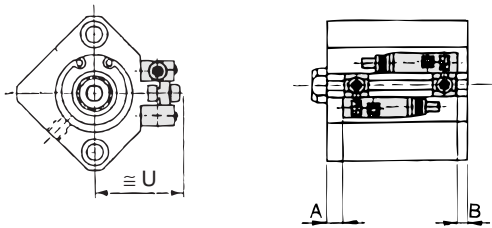

ø32 to ø100

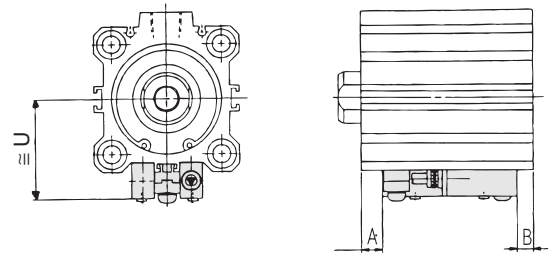

D-A73C
D-A80C
D-J79C

ø12 to ø25

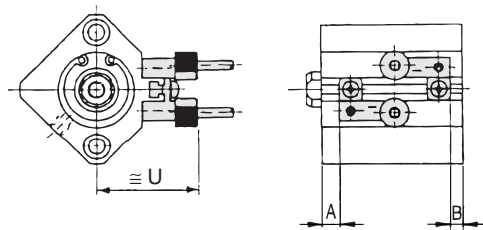

ø32 to ø100

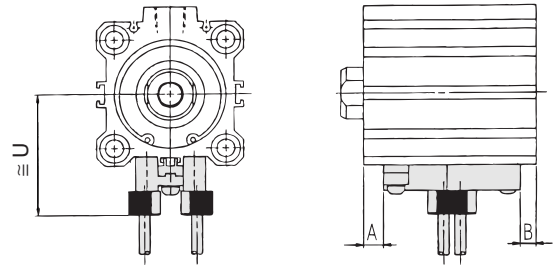

D-A79W
D-F7□WV
D-F7□V

ø12 to ø25

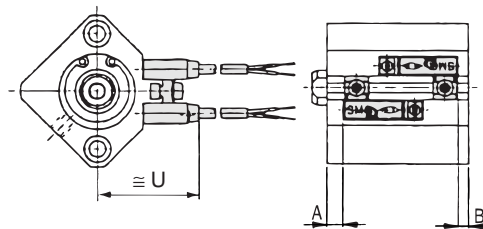

ø32 to ø100

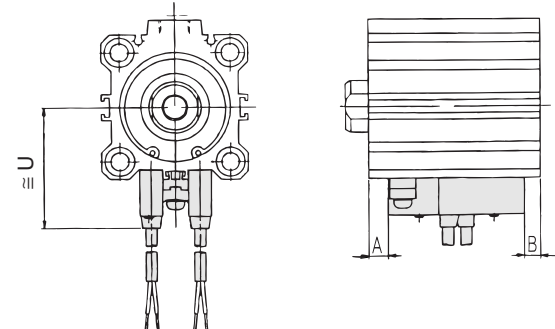

ø32 to ø100

D-A9□
D-F9□

D-A9□V
D-F9□V
D-F9□WV

D-F9□W
D-F9BAL

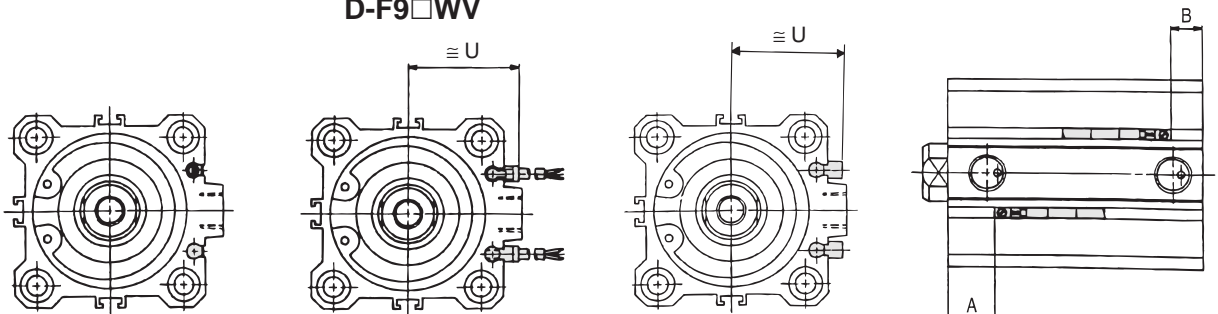

Compact Cylinder/Standard: Double Acting Single Rod *Series CDQ2*

Auto Switch Mounting Position

(mm)

Bore size (mm)	D-A7□/A80		D-A7□H/A80H D-A73C/A80C D-F7□/J79 D-F7□V/J79C		D-A79W		D-F79W D-F7BA D-F7□W D-F7□F D-J79W D-F7□WV		D-A9□ D-A9□V		D-F9□ D-F9□V		D-F9□W D-F9□WV D-F9BAL	
	A	B	A	B	A	B	A	B	A	B	A	B	A	B
12	4.5	5.5	5	6	2	3	9	10	-	-	-	-	-	-
16	7.5	5	8	5.5	5	2.5	12	9.5	-	-	-	-	-	-
20	7.5	6.5	8	7	5	4	12	11	-	-	-	-	-	-
25	7.5	7	8	7.5	5	4.5	12	11.5	-	-	-	-	-	-
32	9.0	6	9.5	6.5	6.5	3.5	13.5	10.5	8	5	12	9	11	8
40	13	8.5	13.5	9	10.5	6	17.5	13	12	7.5	16	11.5	15	10.5
50	11	11.5	11.5	12	8.5	9	15.5	16	10	10.5	14	14.5	13	13.5
63	13.5	14.5	14	15	11	12	18	19	12.5	13.5	16.5	17.5	15.5	16.5
80	17.5	18	18	18.5	15	15.5	22	22.5	16.5	17	20.5	21	19.5	20
100	21	24	21.5	24.5	18.5	21.5	25.5	28.5	20	23	24	27	23	26

Auto Switch Mounting Height

(mm)

Bore size (mm)	D-A7□/A80	D-A7□H D-A80H D-F7□ D-J79 D-F7□W	D-J79W D-F7BAL D-F7□F D-F7NTL	D-A73C D-A80C	D-F7□V D-F7□WV	D-J79C	D-A79W	D-A9□V	D-F9□V D-F9□WV	D-F9□W D-F9BAL
	U	U		U	U	U	U	U	U	U
12	19.5	20.5		26.5	23	26	22	-	-	-
16	22.5	23.5		29.5	26	29	25	-	-	-
20	24.5	25.5		31.5	28	31	27	-	-	-
25	27.5	28.5		34.5	31	34	30	-	-	-
32	31.5	32.5		38.5	35	38	34	27	29	26.5
40	35	36		42	38.5	41.5	37.5	30.5	32.5	30
50	41	42		48	44.5	47.5	43.5	36.5	38.5	36
63	47.5	48.5		54.5	51	54	50	40	42	39.5
80	57.5	58.5		64.5	61	64	60	50	52	49.5
100	67.5	68.5		74.5	71	74	70	60	62	59.5

CUJ

CU

CQS

CQ2

RQ

MU

Auto Switch Mounting

Mount the auto switch as figure below.

ø12 to ø25

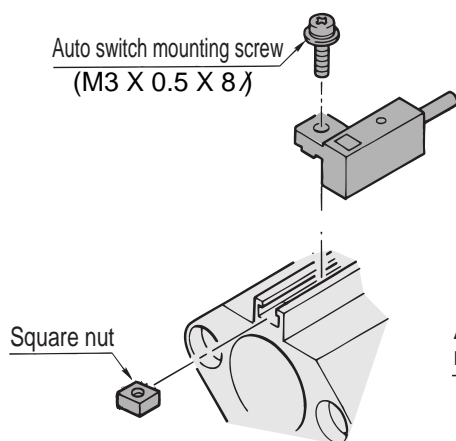

ø32 to ø100

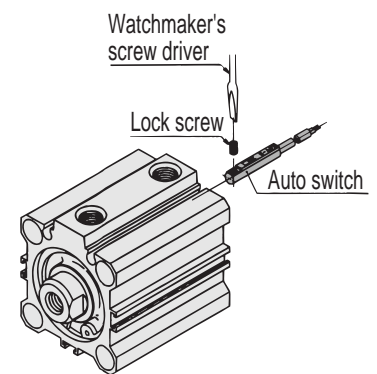
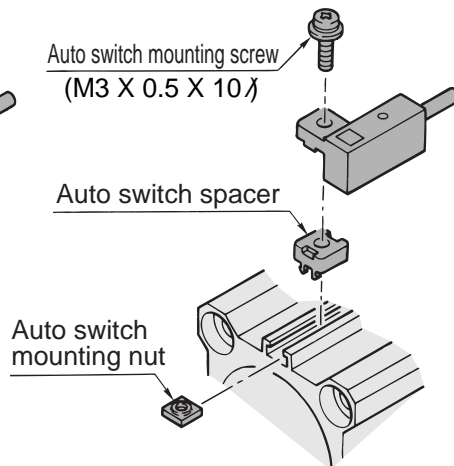

Compact Cylinder/Standard: Double Acting Double Rod *Series CQ2W*



JIS symbol

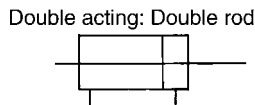

Made to Order

Refer to p.5.4-1 for common made to order specifications and p.5.4-79 for individual specifications.

⚠ Precautions

Be sure to read before handling.
Refer to p.0-39 to 0-46 for Safety Instructions and common precautions.

⚠ Caution

Snap Ring Installation/Removal

- For installation and removal, use an appropriate pair of pliers (tool for installing a C snap ring).
- Exercise caution even when using an appropriate pair of pliers (tool for installing a C snap ring), because of the possibility of the snap ring becoming detached from the tip of the pliers (tool for installing a C snap ring) and flying away, which could injure humans or damage the peripheral equipment. After installing the snap ring, make sure that it is placed securely in the ring groove before supplying air.

Mounting

- When removing a load, be sure to secure the wrench flats of the piston rod on the load side.
- If this is done without securing the piston rod on the load side, be aware that the coupled (screwed-in) portion of the piston rod could become loosened.

Style

Bore size (mm)		12	16	20	25	32	40	50	63	80	100	
Pneumatic	Mounting	Through hole (Standard)	●	●	●	●	●	●	●	●	●	
		Both ends tapped	●	●	●	●	●	●	●	●	●	
	Built-in magnet		●	●	●	●	●	●	●	●	●	
	Piping	Screw-in style	M5 X 0.8	M5 X 0.8	M5 X 0.8	M5 X 0.8	M5 X 0.8 ⁽¹⁾ M5 X 0.8 1/8	1/8	1/4	1/4	3/8	3/8
		One-touch fitting	—	—	—	—	ø6/4 ⁽²⁾	ø6/4	ø8/6	ø8/6	—	—
Rod end male thread		●	●	●	●	●	●	●	●	●	●	
With rubber bumper		●	●	●	●	●	●	●	●	●	●	
Air-hydro	Mounting	Through hole (Standard)	—	—	●	●	●	●	●	●	●	
		Both ends tapped	—	—	●	●	●	●	●	●	●	
	Built-in magnet		—	—	●	●	●	●	●	●	●	
	Piping	Screw-in style	—	—	M5 X 0.8	M5 X 0.8	M5 X 0.8 ⁽¹⁾ M5 X 0.8 1/8	1/8	1/4	1/4	3/8	3/8
Rod end male thread		—	—	●	●	●	●	●	●	●	●	



Note 1) Without auto switch, 5stroke: M5 X 0.8

Note 2) Built-in fitting: Dimensions of ø32, 5stroke are same as cylinder tube with 10 stroke.

Specifications

Style	Pneumatic (Non-lube)	Air hydro
Fluid	Air	Turbine oil ⁽³⁾
Proof pressure	1.5MPa	
Max. operating pressure	1.0MPa	
Ambient and fluid temperature	Without auto switch: -10°C to 70°C (No freezing)	
	With auto switch: -10°C to 60°C (No freezing)	
Rubber bumper	None	—
Rod end thread	Female thread	
Tolerance of rod end thread	JIS class 2	
Tolerance of stroke length	+1.0 0	
Mounting	Through-hole	
Piston speed	50 to 500mm/s	5 to 50mm/s



Note 3) Refer to p.0-43 for cautions on use.

Minimum Operating Pressure

Unit: MPa

Bore size (mm)	12	16	20	25	32	40	50	63	80	100
Pneumatic (Non-lube)	0.07	0.07	0.05	0.05	0.05	0.05	0.05	0.05	0.05	0.05
Air-hydro	—	—	0.18	0.18	0.18	0.10	0.10	0.10	0.10	0.10

Allowable Kinetic Energy

Unit: J

Bore size (mm)	12	16	20	25	32	40	50	63	80	100
Standard	0.022	0.038	0.055	0.09	0.15	0.26	0.46	0.77	1.36	2.27
With rubber bumper	0.043	0.075	0.11	0.18	0.29	0.52	0.91	1.54	2.71	4.54

Standard Stroke

Pneumatic (Non-lube) (mm)

Bore size	Standard stroke
12, 16	5, 10, 15, 20, 25, 30
20, 25	5, 10, 15, 20, 25, 30, 35, 40, 45, 50
32, 40	5, 10, 15, 20, 25, 30, 35, 40, 50, 75, 100
50, 63	10, 15, 20, 25, 30,
80, 100	35, 40, 45, 50, 75, 100

Air-hydro (mm)

Bore size	Standard stroke
20, 25	5, 10, 15, 20, 25, 30,
32, 40	35, 40, 45, 50
50, 63	10, 15, 20, 25, 30,
80, 100	35, 40, 45, 50, 75, 100

Auto Switch Mounting Bracket Part No.

Bore size (mm)	Part No.	Note	Applicable switch	
			Reed switch	Solid state switch
12, 16 20, 25	BQ-1	<ul style="list-style-type: none"> Switch mounting screw (M3 X 0.5 X 8 ℓ) Square nut 	D-A7, A8 D-A73C, A80C D-A7□H, A80H D-A79W	D-F7□, J79 D-F7□V D-J79C D-F7□W, J79W D-F7□WV D-F7BA D-F7□F D-F7NT
32, 40 50, 63 80, 100	BQ-2	<ul style="list-style-type: none"> Switch mounting screw (M3 X 0.5 X 10 ℓ) Switch spacer Switch mounting nut 		

Series CQ2W

Theoretical Force

Unit: N

Bore size (mm)	Operating pressure(MPa)		
	0.3	0.5	0.7
12	25	42	59
16	45	75	106
20	71	118	165
25	113	189	264
32	181	302	422
40	317	528	739
50	495	825	1150
63	841	1400	1960
80	1360	2270	3170
100	2140	3570	5000

Weight

Unit: g

Bore size (mm)	Cylinder stroke(mm)											
	5	10	15	20	25	30	35	40	45	50	75	100
12	42	49	56	63	70	77	-	-	-	-	-	-
16	59	68	77	86	95	104	-	-	-	-	-	-
20	89	104	119	134	149	164	179	194	209	224	-	-
25	119	136	153	170	187	204	221	238	255	272	-	-
32	192	220	244	268	292	316	340	364	388	412	532	652
40	292	323	354	385	416	447	478	509	540	571	726	881
50	-	528	573	618	663	708	753	798	843	888	1113	1338
63	-	676	714	753	792	831	870	909	948	987	1182	1377
80	-	1241	1325	1409	1493	1577	1661	1745	1829	1913	2333	2753
100	-	2106	2225	2344	2463	2582	2701	2820	2939	3058	3653	4248

Option Weights

Unit: g

Bore size (mm)	12	16	20	25	32	40	50	63	80	100	
Both ends tapped	2	2	6	6	6	6	6	19	45	45	
Rod end male thread	Male thread	3	6	12	24	52	54	106	106	240	350
male thread	Nut	2	4	8	16	34	34	64	64	98	232
Rubber bumper	0	0	-2	-2	-3	-7	-12	-20	-34	-57	
One-touch fitting	-	-	-	-	12	12	21	21	-	-	
Foot (including bolt)	57	71	170	195	159	171	267	349	735	1117	
Flange (including bolt)	57	69	139	161	180	214	373	559	1056	1365	

Calculation example: CQ2WF32-20DCM

- Cylinder weight: CQ2WB32-20D 268g
- Option weight: Both ends tapped 6g
- Rod end nut 86g
- With rubber bumper -3g
- Flange 180g
- 537g

Mounting Bolt for CQ2WB

Special long bolt for through-hole mounting is available as option.

How to Order: Specify the required bolts

Example) Bolt M3 X 35 ℓ 4pcs.

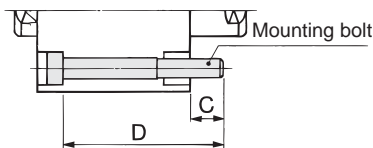

Model	C	D	Mounting bolt
CQ2WB12-5D	8.3	35	M3 X 35 ℓ
-10D		40	X 40 ℓ
-15D		45	X 45 ℓ
-20D		50	X 50 ℓ
-25D		55	X 55 ℓ
-30D		60	X 60 ℓ
CQ2WB16-5D	7.5	35	M3 X 35 ℓ
-10D		40	X 40 ℓ
-15D		45	X 45 ℓ
-20D		50	X 50 ℓ
-25D		55	X 55 ℓ
-30D		60	X 60 ℓ
CQ2WB20-5D	6	30	X 30 ℓ
-10D		35	X 35 ℓ
-15D		40	X 40 ℓ
-20D		45	X 45 ℓ
-25D		50	X 50 ℓ
-30D		55	X 55 ℓ
-35D		60	X 60 ℓ
-40D		65	X 65 ℓ
-45D		70	X 70 ℓ
-50D		75	X 75 ℓ
CQ2WB25-5D	8	35	M5 X 35 ℓ
-10D		40	X 40 ℓ
-15D		45	X 45 ℓ
-20D		50	X 50 ℓ
-25D		55	X 55 ℓ
-30D		60	X 60 ℓ
-35D		65	X 65 ℓ
-40D		70	X 70 ℓ
-45D		75	X 75 ℓ
-50D		80	X 80 ℓ

Model	C	D	Mounting bolt
CQ2WB32-5D	6.5	35	M5 X 35 ℓ
-10D		40	X 40 ℓ
-15D		45	X 45 ℓ
-20D		50	X 50 ℓ
-25D		55	X 55 ℓ
-30D		60	X 60 ℓ
-35D		65	X 65 ℓ
-40D		70	X 70 ℓ
-45D		75	X 75 ℓ
-50D		80	X 80 ℓ
CQ2WB40-5D	7	45	M5 X 45 ℓ
-10D		50	X 50 ℓ
-15D		55	X 55 ℓ
-20D		60	X 60 ℓ
-25D		65	X 65 ℓ
-30D		70	X 70 ℓ
-35D		75	X 75 ℓ
-40D		80	X 80 ℓ
-45D		85	X 85 ℓ
-50D		90	X 90 ℓ
CQ2WB50-10D	12.5	55	M6 X 55 ℓ
-15D		60	X 60 ℓ
-20D		65	X 65 ℓ
-25D		70	X 70 ℓ
-30D		75	X 75 ℓ
-35D		80	X 80 ℓ
-40D		85	X 85 ℓ
-45D		90	X 90 ℓ
-50D		95	X 95 ℓ
-75D		130	X 130 ℓ
-100D	155	X 155 ℓ	

Model	C	D	Mounting bolt
CQ2WB63-10D	13.5	55	M8 X 55 ℓ
-15D		60	X 60 ℓ
-20D		65	X 65 ℓ
-25D		70	X 70 ℓ
-30D		75	X 75 ℓ
-35D		80	X 80 ℓ
-40D		85	X 85 ℓ
-45D		90	X 90 ℓ
-50D		95	X 95 ℓ
-75D		130	X 130 ℓ
CQ2WB80-10D	12.5	60	M10 X 60 ℓ
-15D		65	X 65 ℓ
-20D		70	X 70 ℓ
-25D		75	X 75 ℓ
-30D		80	X 80 ℓ
-35D		85	X 85 ℓ
-40D		90	X 90 ℓ
-45D		95	X 95 ℓ
-50D		100	X 100 ℓ
-75D		135	X 135 ℓ
CQ2WB100-10D	13	70	M10 X 70 ℓ
-15D		75	X 75 ℓ
-20D		80	X 80 ℓ
-25D		85	X 85 ℓ
-30D		90	X 90 ℓ
-35D		95	X 95 ℓ
-40D		100	X 100 ℓ
-45D		105	X 105 ℓ
-50D		110	X 110 ℓ
-75D		145	X 145 ℓ
-100D	170	X 170 ℓ	

Compact Cylinder/Standard: Double Acting Double Rod *Series CQ2W*

Construction

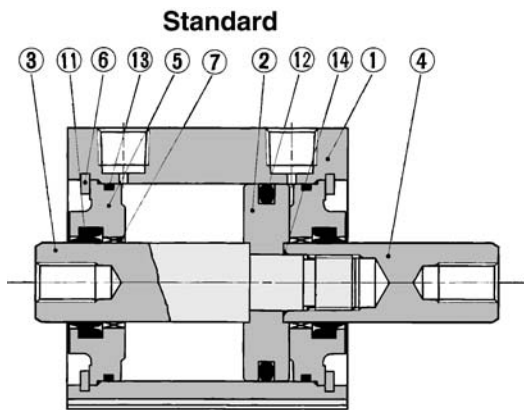

With rubber bumper

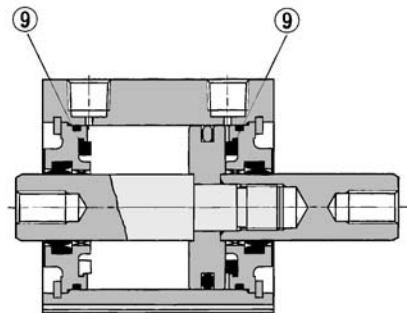

With One-touch fitting

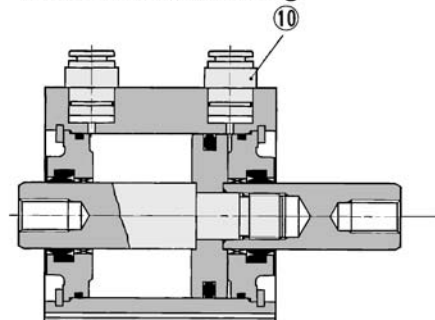

Rod end male thread

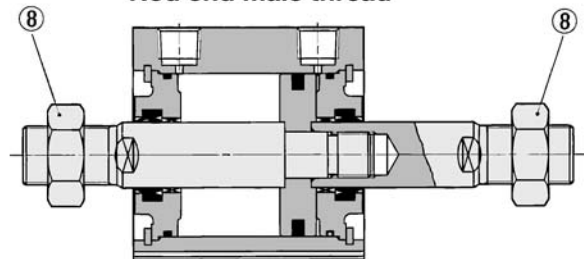

Component Parts

No.	Description	Material	Note
①	Cylinder tube	Aluminum alloy	Hard anodized
②	Piston	Aluminum alloy	Chromated
③	Piston rod A	Stainless steel	ø12 to ø25
		Carbon steel	ø32 to ø100, Hard chromated
④	Piston rod B	Stainless steel	ø12 to ø25
		Carbon steel	ø32 to ø100, Hard chrome plated
⑤	Collar	Aluminum bearing alloy	ø12 to ø40, Anodized
		Aluminum alloy casting	ø50 to ø100, Chromated, plated
⑥	Snap ring	Carbon tool steel	Phosphate coating
⑦	Bushing	Lead bronze casting	For ø50 or larger
⑧	Rod end nut	Carbon steel	Nickel plated
⑨	Bumper	Urethane	
⑩	One-touch fitting		ø32 to ø63
⑪*	Rod seal	NBR	
⑫*	Piston seal	NBR	
⑬*	Tube gasket	NBR	
⑭	Piston gasket	NBR	

Replacement Parts: Seal Kits (Pneumatic)

Bore size (mm)	Kit No.	Contains
12	CQ2WB12-PS	Kits include items ⑪, ⑫ and ⑬ from the table above.
16	CQ2WB16-PS	
20	CQ2WB20-PS	
25	CQ2WB25-PS	
32	CQ2WB32-PS	
40	CQ2WB40-PS	
50	CQ2WB50-PS	
63	CQ2WB63-PS	
80	CQ2WB80-PS	
100	CQ2WB100-PS	

Replacements Parts: Seal Kits (Air-hydro)

Bore size (mm)	Kit No.	Contains
20	CQ2WBH20-PS	Kits include items ⑪, ⑫ and ⑬ from the table above.
25	CQ2WBH25-PS	
32	CQ2WBH32-PS	
40	CQ2WBH40-PS	
50	CQ2WBH50-PS	
63	CQ2WBH63-PS	
80	CQ2WBH80-PS	
100	CQ2WBH100-PS	

*Seal kits consist of items ⑪, ⑫ and ⑬ contained in one kit, and can be ordered using the kit number for each respective tube bore size.

CUJ

CU

CQS

CQ2

RQ

MU

Copper Free

20 — CQ2WB Bore size — Stroke D (C) (M)

• Copper free

• ø12, ø16, ø20, ø25, ø32, ø40, ø50, ø63, ø80, ø100

To eliminate influences of copper ions or halogen ions during CRT manufacturing processes, copper and fluorine materials are not used as component parts.

Specifications

Action	Double acting double rod
Bore size	ø12, ø16, ø20, ø25, ø32, ø40, ø50, ø63, ø80, ø100
Proof pressure	1.5MPa
Max. operating press.	1.0MPa
Rubber bumper	None
Piping	Screw-in piping
Piston speed	50 to 500mm/s
Mounting	Through-hole
Auto switch	Attachable

Series CDQ2 Auto Switch Specifications

* Refer to p.5.3-2 for details of auto switch.



How to Order

Refer to p.2.3-22 for How to Order.

Minimum Strokes for Auto Switch Mounting

(mm)

Number of auto switches	D-F7□V D-J79C D-F9□V	D-A7□ D-A80 D-A73C D-A80C D-A9□V D-A9□	D-F7□WV D-F9□WV	D-A7□H D-A80H D-F7□ D-J79 D-F9B D-F9P D-F9□W	D-A79W	D-F7□W D-J79W D-F7BAL D-F79F D-F9BAL	D-F7LF	D-F9N
1	5	5	10	15	15	20	25	10
2	5	10	15	15	20	20	25	10

Weight

Unit: g

Bore (mm)	Cylinder stroke (mm)											
	5	10	15	20	25	30	35	40	45	50	75	100
12	55	63	71	79	87	95	-	-	-	-	-	-
16	88	99	110	121	132	143	-	-	-	-	-	-
20	135	152	169	186	203	220	237	254	271	288	-	-
25	182	199	216	233	250	267	284	301	318	335	-	-
32	247	271	295	319	343	367	391	415	439	463	487	511
40	370	401	432	463	494	525	556	587	618	649	680	711
50	-	647	692	737	782	827	872	917	962	1007	1052	1097
63	-	833	872	911	950	989	1028	1067	1106	1145	1184	1223
80	-	1500	1584	1668	1752	1836	1920	2004	2088	2172	2256	2340
100	-	2501	2620	2739	2858	2977	3096	3215	3334	3453	3572	3691

Weight/Auto Switch Mounting Bracket

Part No.	Bore size	Weight (g)
BQ-1	ø12 to ø25	1.5
BQ-2	ø32 to ø100	1.5

* Refer to p.5.3-75 for auto switch weight.

Option Weights

Unit: g

Bore size (mm)	12	16	20	25	32	40	50	63	80	100
Both end tapped	1	1	3	3	6	6	6	19	45	45
Rod end male thread	Male thread	3	6	12	24	52	54	106	106	240
	Nut	2	4	8	16	34	34	64	64	98
Rubber bumper	0	0	-2	-2	-3	-7	-12	-19	-34	-54
One-touch fitting	-	-	-	-	12	12	21	21	-	-
Foot (including bolt)	52	65	153	177	159	171	267	349	735	1117
Flange (including bolt)	54	67	131	153	180	214	373	559	1056	1365

Calculation example: CDQ2WF32-20DCM

• Cylinder weight: CDQ2WB32-20D..... 319g

• Option weight: Both ends tapped..... 6g

Rod end male thread.... 86g

With rubber bumper..... -3g

Front flange..... 180g

588g

If auto switches are to be installed, the weight that corresponds to the number of auto switches and mounting brackets to be used must be added.

Construction

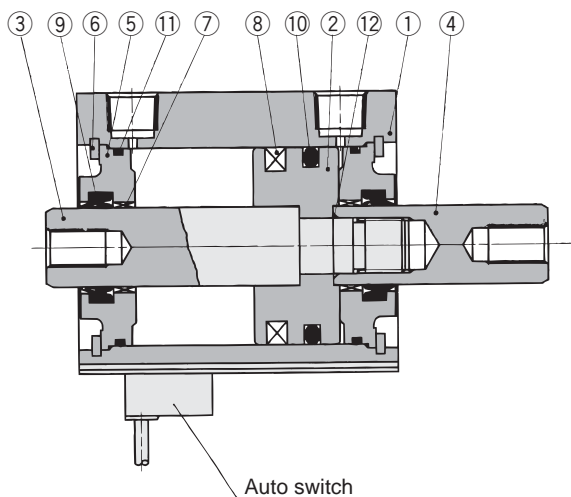

Auto switch

Component Parts

No.	Description	Material	Note
①	Cylinder tube	Aluminum alloy	Hard anodized
②	Piston	Aluminum alloy	Chromated
③	Piston rod A	Stainless steel	ø12 to ø25
		Carbon steel	ø32 to ø100, Hard chrome plated
④	Piston rod B	Stainless steel	ø12 to ø25
		Carbon steel	ø32 to ø100, Hard chrome plated
⑤	Collar	Aluminum bearing alloy	ø12 to ø40, Anodized
		Aluminum alloy casting	ø50 to ø100, Chromated
⑥	Snap ring	Carbon tool steel	Phosphate coating
⑦	Bushing	Lead bronze casting	For ø50 or larger
⑧	Magnet	-	-
⑨*	Rod seal	NBR	
⑩*	Piston seal	NBR	
⑪*	Tube gasket	NBR	
⑫	Piston gasket	NBR	

Replacement Parts: Seal Kits (Pneumatic)

Bore size (mm)	Kit No.	Contents
12	CQ2WB12-PS	Kits include items ⑨, ⑩ and ⑪ from the table above.
16	CQ2WB16-PS	
20	CQ2WB20-PS	
25	CQ2WB25-PS	
32	CQ2WB32-PS	
40	CQ2WB40-PS	
50	CQ2WB50-PS	
63	CQ2WB63-PS	
80	CQ2WB80-PS	
100	CQ2WB100-PS	

* Seal kits consist of items ⑨, ⑩ and ⑪ contained in one kit, and can be ordered using the kit number for each respective tube bore size.

Replacement Parts: Seal Kits (Air-hydro)

Bore size (mm)	Kit No.	Contents
20	CQ2WBH20-PS	Kits include items ⑨, ⑩ and ⑪ from the table above.
25	CQ2WBH25-PS	
32	CQ2WBH32-PS	
40	CQ2WBH40-PS	
50	CQ2WBH50-PS	
63	CQ2WBH63-PS	
80	CQ2WBH80-PS	
100	CQ2WBH100-PS	

* Seal kits consist of items ⑨, ⑩ and ⑪ contained in one kit, and can be ordered using the kit number for each respective tube bore size.

Compact Cylinder/Standard: Double Acting Double Rod Series **CDQ2W**

Mounting Bolt for CDQ2 with Auto Switch

Special long bolt for through-hole mounting is available as option.

How to Order: Specify the required bolts.

Example) Bolt M3 X 40 ℓ 4pcs.

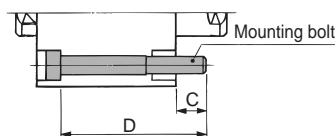

Model	C	D	Mounting bolt
CDQ2WB12-5DC	6.1	40	M3 X 40 ℓ
-10DC		45	X 45 ℓ
-15DC		50	X 50 ℓ
-20DC		55	X 55 ℓ
-25DC		60	X 60 ℓ
-30DC		65	X 65 ℓ
CDQ2WB16-5D	7.5	45	M3 X 45 ℓ
-10D		50	X 50 ℓ
-15D		55	X 55 ℓ
-20D		60	X 60 ℓ
-25D		65	X 65 ℓ
-30D		70	X 70 ℓ
CDQ2WB20-5D	9	45	M5 X 45 ℓ
-10D		50	X 50 ℓ
-15D		55	X 55 ℓ
-20D		60	X 60 ℓ
-25D		65	X 65 ℓ
-30D		70	X 70 ℓ
-35D		75	X 75 ℓ
-40D		80	X 80 ℓ
-45D		85	X 85 ℓ
-50D		90	X 90 ℓ
CDQ2WB25-5D	8	45	M5 X 45 ℓ
-10D		50	X 50 ℓ
-15D		55	X 55 ℓ
-20D		60	X 60 ℓ
-25D		65	X 65 ℓ
-30D		70	X 70 ℓ
-35D		75	X 75 ℓ
-40D		80	X 80 ℓ
-45D		85	X 85 ℓ
-50D		90	X 90 ℓ

Model	C	D	Mounting bolt	
CDQ2WB32-5D	6.5	45	M5 X 45 ℓ	
-10D		50	X 50 ℓ	
-15D		55	X 55 ℓ	
-20D		60	X 60 ℓ	
-25D		65	X 65 ℓ	
-30D		70	X 70 ℓ	
-35D		75	X 75 ℓ	
-40D		80	X 80 ℓ	
-45D		85	X 85 ℓ	
-50D		90	X 90 ℓ	
-75D	115	X 115 ℓ		
-100D	140	X 140 ℓ		
CDQ2WB40-5D	7	55	M5 X 55 ℓ	
-10D		60	X 60 ℓ	
-15D		65	X 65 ℓ	
-20D		70	X 70 ℓ	
-25D		75	X 75 ℓ	
-30D		80	X 80 ℓ	
-35D		85	X 85 ℓ	
-40D		90	X 90 ℓ	
-45D		95	X 95 ℓ	
-50D		100	X 100 ℓ	
-75D		125	X 125 ℓ	
-100D		150	X 150 ℓ	
CDQ2WB50-10D		12.5	65	M6 X 65 ℓ
-15D			70	X 70 ℓ
-20D			75	X 75 ℓ
-25D	80		X 80 ℓ	
-30D	85		X 85 ℓ	
-35D	90		X 90 ℓ	
-40D	95		X 95 ℓ	
-45D	100		X 100 ℓ	
-50D	105		X 105 ℓ	
-75D	130		X 130 ℓ	
-100D	155		X 155 ℓ	

Model	C	D	Mounting bolt
CDQ2WB63-10D	13.5	65	M8 X 65 ℓ
-15D		70	X 70 ℓ
-20D		75	X 75 ℓ
-25D		80	X 80 ℓ
-30D		85	X 85 ℓ
-35D		90	X 90 ℓ
-40D		95	X 95 ℓ
-45D		100	X 100 ℓ
-50D		105	X 105 ℓ
-75D		130	X 130 ℓ
-100D	155	X 155 ℓ	
CDQ2WB80-10D	12.5	70	M10 X 70 ℓ
-15D		75	X 75 ℓ
-20D		80	X 80 ℓ
-25D		85	X 85 ℓ
-30D		90	X 90 ℓ
-35D		95	X 95 ℓ
-40D		100	X 100 ℓ
-45D		105	X 105 ℓ
-50D		110	X 110 ℓ
-75D		135	X 135 ℓ
-100D	160	X 160 ℓ	
CDQ2WB100-10D	13	80	M10 X 80 ℓ
-15D		85	X 85 ℓ
-20D		90	X 90 ℓ
-25D		95	X 95 ℓ
-30D		100	X 100 ℓ
-35D		105	X 105 ℓ
-40D		110	X 110 ℓ
-45D		115	X 115 ℓ
-50D		120	X 120 ℓ
-75D		145	X 145 ℓ
-100D	170	X 170 ℓ	

CUJ

CU

CQS

CQ2

RQ

MU

Series CQ2W/CDQ2W

Auto Switch Mounting Position (at Stroke End) and Mounting Height

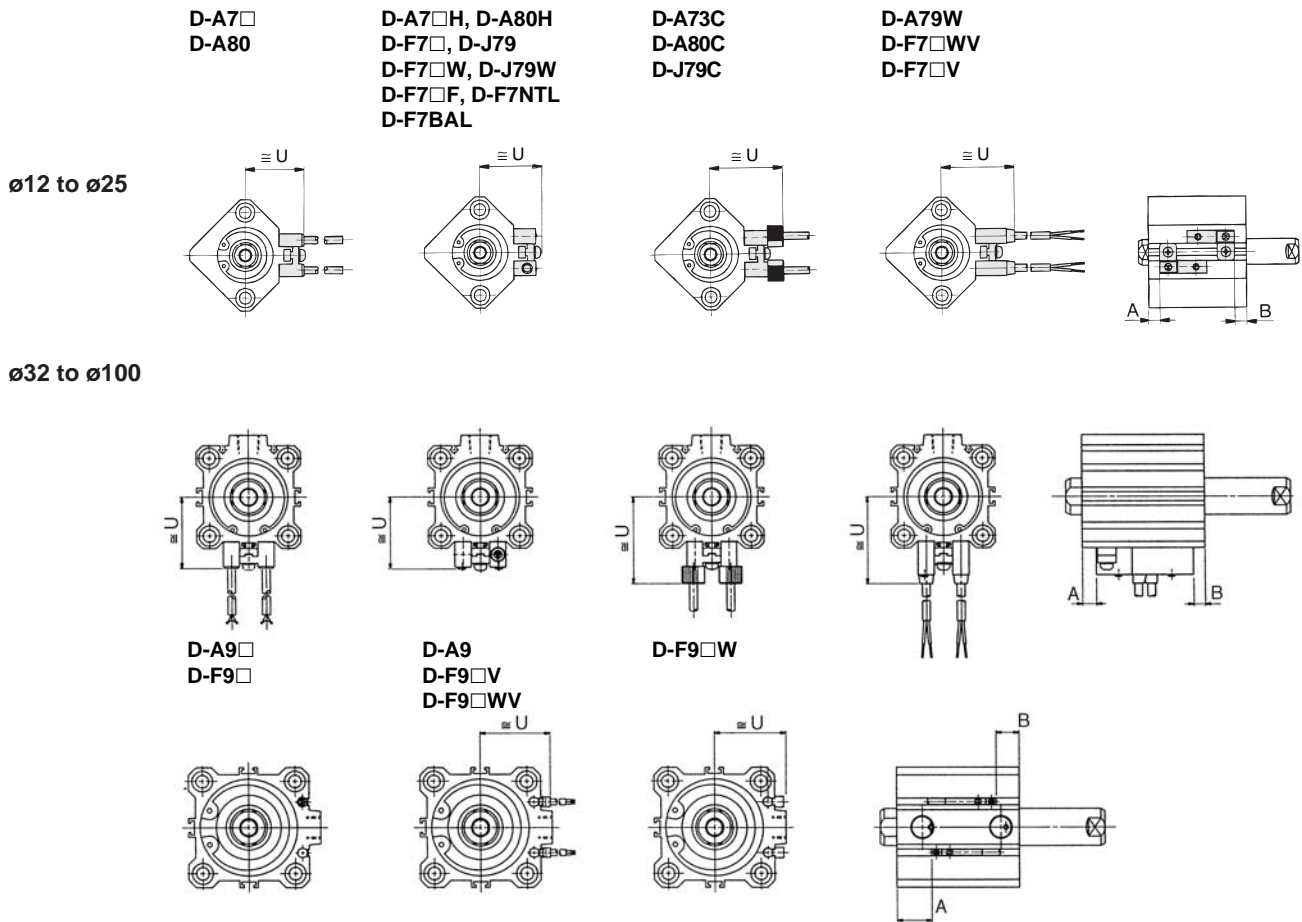

Auto Switch Mounting Position

(mm)

Bore (mm)	D-A7□/A80		D-A7□H, A80H D-A73C, A80C D-F7□, J79 D-F7□V, J79C		D-A79W		D-F7BAL D-F7□W D-F7□F D-J79W D-F7□WV		D-A9□ D-A9□V		D-F9□ D-F9□V		D-F9□W D-F9□WV D-F9BAL	
	A	B	A	B	A	B	A	B	A	B	A	B	A	B
12	4.5	10	5	10.5	2	7.5	9	14.5	—	—	—	—	—	—
16	7.5	10.5	8	11	5	8	12	15	—	—	—	—	—	—
20	7.5	13	8	13.5	5	10.5	12	17.5	—	—	—	—	—	—
25	7.5	13	8	13.5	5	10.5	12	17.5	—	—	—	—	—	—
32	9	13.5	9.5	14	6.5	11	13.5	18	8	12.5	12	16.5	11	15.5
40	13	19	13.5	19.5	10.5	16.5	17.5	23.5	12	18	16	22	15	21
50	11	21.5	11.5	22	8.5	19	15.5	26	10	20.5	14	24.5	13	23.5
63	13.5	20.5	14	21	11	18	18	25	12.5	19.5	16.5	23.5	15.5	22.5
80	17.5	29	18	29.5	15	26.5	22	33.5	16.5	28	20.5	32	19.5	31
100	21.0	31.5	—	32	18.5	29	25.5	36	20	30.5	24	34.5	23	33.5

Auto Switch Mounting Height

(mm)

Bore (mm)	D-A7□/A80	D-A7□H D-A80H D-F7□ D-J79 D-F7□W	D-J79W D-F9BAL D-F7□F D-F7NTL	D-A73C D-A80C	D-F7□V D-F7□WV	D-J79C	D-A79W	D-A9□V	D-F9□V D-F9□WV	D-F9□W D-F9BAL
	U	U	U	U	U	U	U	U	U	U
12	19.5	20.5	—	26.5	23	26	22	—	—	—
16	22.5	23.5	—	29.5	26	29	25	—	—	—
20	24.5	25.5	—	31.5	28	31	27	—	—	—
25	27.5	28.5	—	34.5	31	34	30	—	—	—
32	31.5	32.5	—	38.5	35	38	34	27	29	26.5
40	35	36	—	42	38.5	41.5	37.5	30.5	32.5	30
50	41	42	—	48	44.5	47.5	43.5	36.5	38.5	36
63	47.5	48.5	—	54.5	51	54	50	40	42	39.5
80	57.5	58.5	—	64.5	61	64	60	50	52	49.5
100	67.5	68.5	—	74.5	71	74	70	60	62	59.5

CUJ

CU

CQS

CQ2

RQ

MU

Series CQ2W/CDQ2W

ø12 to ø25 Without Auto Switch

Both ends tapped: CQ2WA

Standard (Through-hole)/CQ2WB

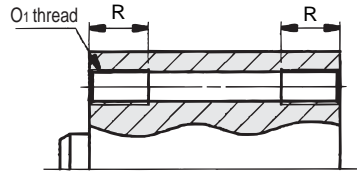

Both ends tapped (mm)

Bore (mm)	O1	R
12	M4 X 0.7	7
16	M4 X 0.7	7
20	M6 X 1.0	10
25	M6 X 1.0	10

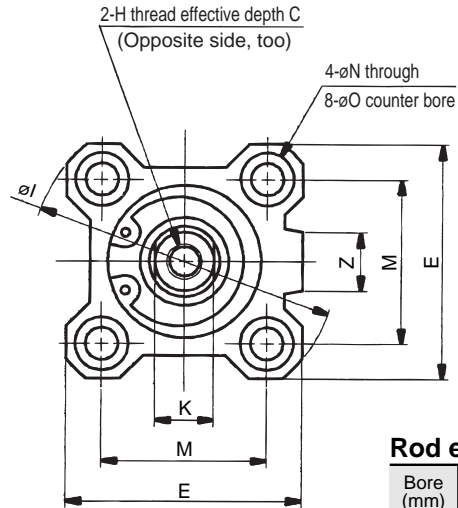
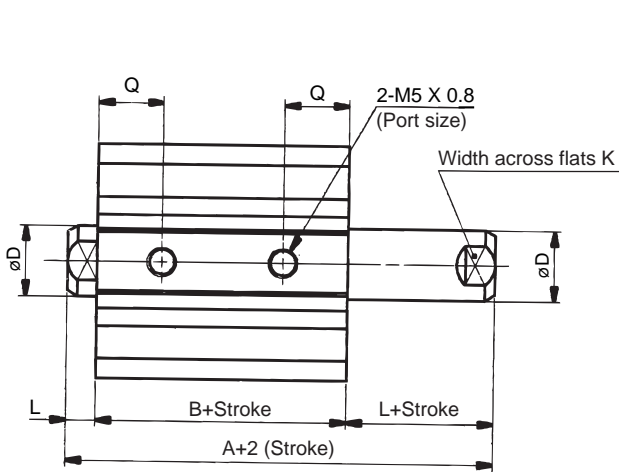

Rod end male thread (mm)

Bore (mm)	A1	C1	H1	L1	X
12	53.2	9	M5 X 0.8	14	10.5
16	57	10	M6 X 1.0	15.5	12
20	63	12	M8 X 1.25	18.5	14
25	74	15	M10 X 1.25	22.5	17.5

Rod end male thread

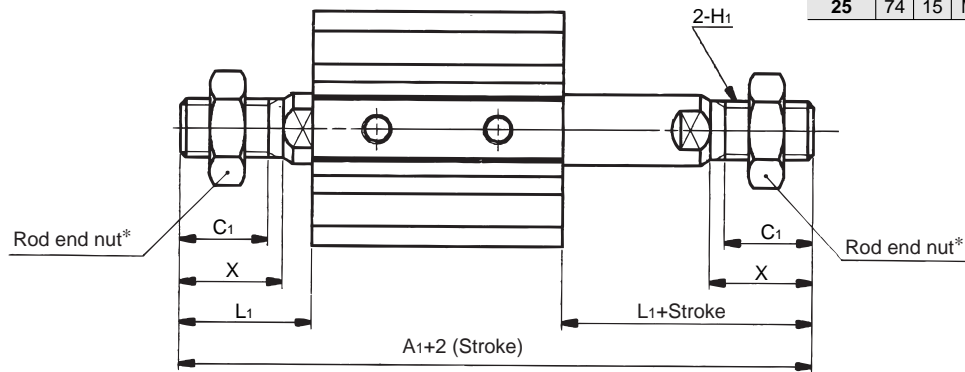

Standard

(mm)

Bore (mm)	Stroke range (mm)	A	B	C	D	E	H	I	K	L	M	N	O	Q	Z
12	5 to 30	32.2	25.2	6	6	25	M3 X 0.5	32	5	3.5	15.5	3.5	6.5 Depth 3.5	10	-
16	5 to 30	33	26	8	8	29	M4 X 0.7	38	6	3.5	20	3.5	6.5 Depth 3.5	10	10
20	5 to 50	35	26	7	10	36	M5 X 0.8	47	8	4.5	25.5	5.5	9 Depth 7	9.5	10
25	5 to 50	39	29	12	12	40	M6 X 1.0	52	10	5	28	5.5	9 Depth 7	11	10

Note) Dimensions of model with rubber bumper are same as standard shown above.

* Refer to p.2.3-18 & 19 for rod end nut and mounting bracket.

Compact Cylinder/Standard: Double Acting Double Rod *Series CQ2W/CDQ2W*

Foot/CQ2WL

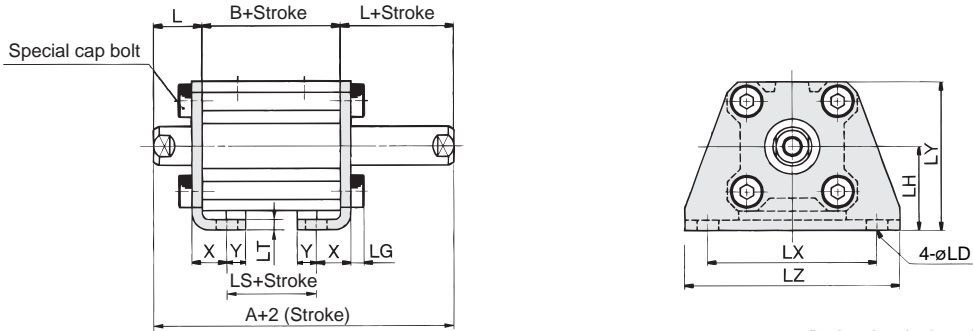

Rod end male thread

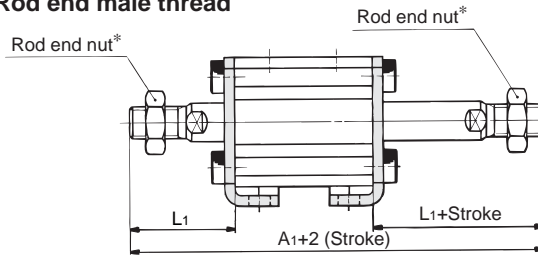

Rod end male thread (mm)

Bore size (mm)	A1	L1
12	73.2	24
16	77	25.5
20	83	28.5
25	94	32.5

Foot

Bore (mm)	Stroke range(mm)	A	B	L	LD	LG	LH	LS	LT	LX	LY	LZ	X	Y
12	5 to 30	52.2	25.2	13.5	4.5	2.8	17	13.2	2	34	29.5	44	8	4.5
16	5 to 30	53	26	13.5	4.5	2.8	19	14	2	38	33.5	48	8	5
20	5 to 50	55	26	14.5	6.6	4	24	14	3.2	48	42	62	9.2	5.8
25	5 to 50	59	29	15	6.6	4	26	14	3.2	52	46	66	10.7	5.8

Flange/CQ2WL

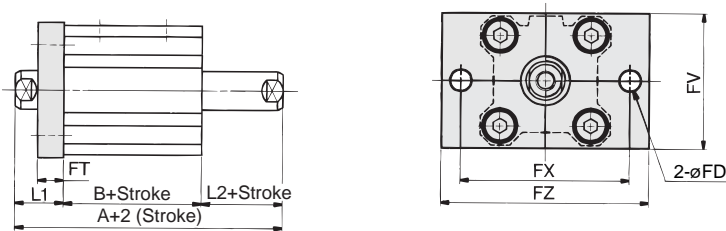

Rod end male thread

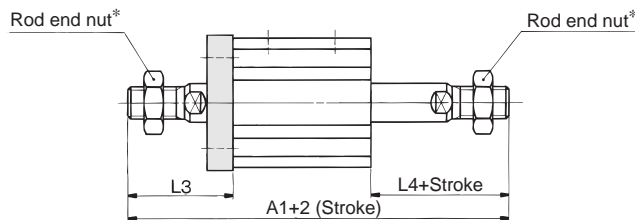

Rod end male thread (mm)

Bore size (mm)	A1	L3	L4
12	63.2	24	14
16	67	25.5	15.5
20	73	28.5	18.5
25	84	32.5	22.5

Flange

Bore (mm)	Stroke range(mm)	A	B	FD	FT	FV	FX	FZ	L1	L2
12	5 to 30	42.2	25.2	4.5	5.5	25	45	55	13.5	3.5
16	5 to 30	43	26	4.5	5.5	30	45	55	13.5	3.5
20	5 to 50	45	26	6.6	8	39	48	60	14.5	4.5
25	5 to 50	49	29	6.6	8	42	52	64	15	5

* Refer to p.2.3-18 & 19 for rod end nut and mounting brackets.

CUJ

CU

CQS

CQ2

RQ

MU

Series CQ2W/CDQ2W

ø12 to ø25 With Auto Switch

Standard (Through-hole)/CDQ2WB

Both ends tapped: CDQ2WA

Both ends tapped (mm)

Bore (mm)	O ₁	R
12	M4 X 0.7	7
16	M4 X 0.7	7
20	M6 X 1.0	10
25	M6 X 1.0	10

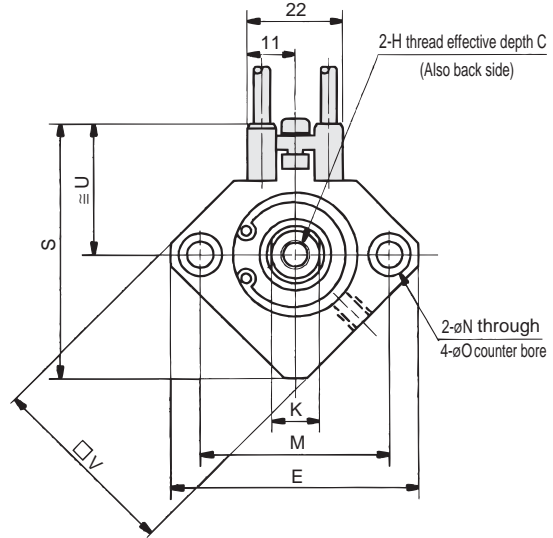
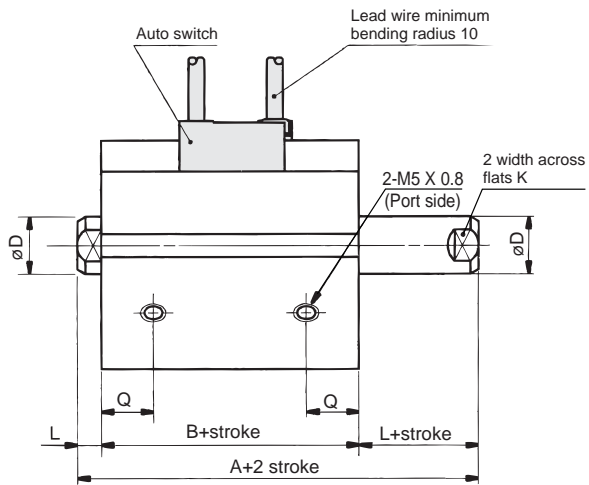
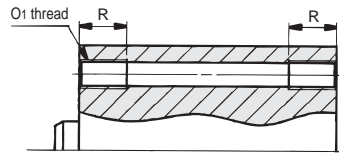

Rod end male thread

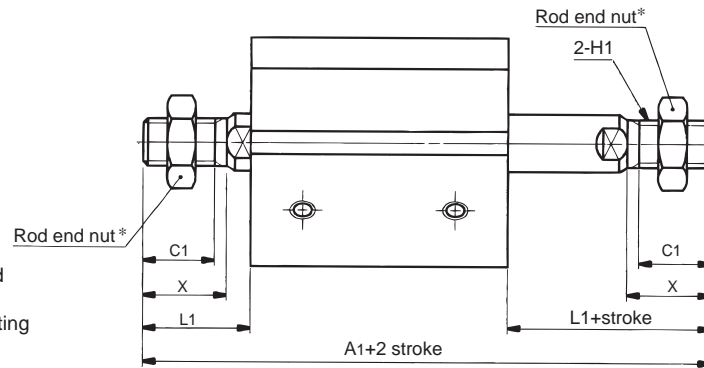

Rod end male thread (mm)

Bore (mm)	A ₁	C ₁	H ₁	L ₁	X
12	60.4	9	M5 X 0.8	14	10.5
16	67	10	M6 X 1.0	15.5	12
20	75	12	M8 X 1.25	18.5	14
25	84	15	M10 X 1.25	22.5	17.5

Auto switch shown above is D-A73 and D-A80.
Refer to p.2.3-20 for auto switch mounting position and mounting height.

Standard

Bore (mm)	Stroke range (mm)	A	B	C	D	E	H	K	L	M	N	O	Q	S	U	V
12	5 to 30	39.4	32.4	6	6	32	M3 X 0.5	5	3.5	22	3.5	6.5 Depth 3.5	10.5	35.5	19.5	25
16	5 to 30	43	36	8	8	38	M4 X 0.7	6	3.5	28	3.5	6.5 Depth 3.5	10	41.5	22.5	29
20	5 to 50	47	38	7	10	47	M5 X 0.8	8	4.5	36	5.5	9 Depth 7	10.5	48	24.5	36
25	5 to 50	49	39	12	12	52	M6 X 1.0	10	5	40	5.5	9 Depth 7	11	53.5	27.5	40

Note 1) Dimensions of model with rubber bumper are same as standard shown above.

*Refer to p.2.3-18 & 19 for rod end nut and optional brackets.

Compact Cylinder/Standard: Double Acting Double Rod Series **CDQ2W**

Foot/CDQ2WL

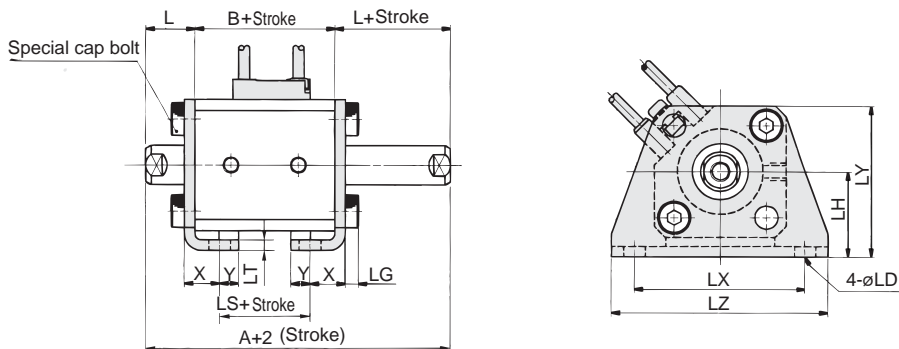

Rod end male thread

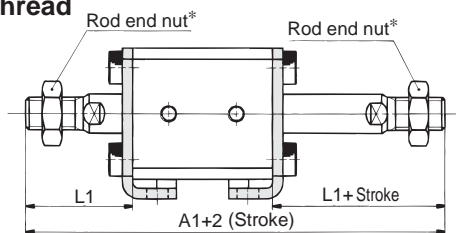

Rod end male thread (mm)

Bore (mm)	A1	L1
12	80.4	24
16	87	25.5
20	95	28.5
25	104	32.5

Foot

Bore (mm)	Stroke range (mm)	A	B	L	LD	LG	LH	LS	LT	LX	LY	LZ	X	Y
12	5 to 30	59.4	32.4	13.5	4.5	2.8	17	20.4	2	34	29.5	44	8	4.5
16	5 to 30	63	36	13.5	4.5	2.8	19	24	2	38	33.5	48	8	5
20	5 to 50	67	38	14.5	6.6	4	24	26	3.2	48	42	62	9.2	5.8
25	5 to 50	69	39	15	6.6	4	26	24	3.2	52	46	66	10.7	5.8

Flange/CDQ2WF

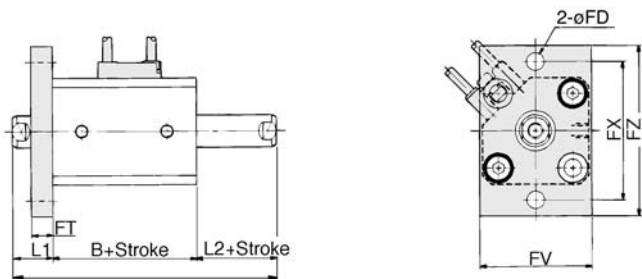

Rod end male thread

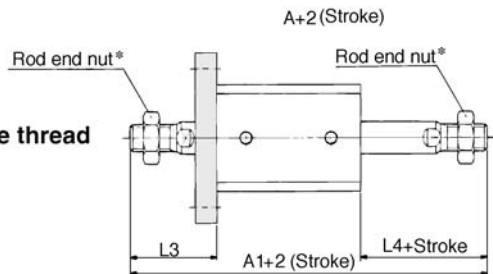

Rod end male thread (mm)

Bore (mm)	A1	L3	L4
12	70.4	24	14
16	77	25.5	15.5
20	85	28.5	18.5
25	94	32.5	22.5

Flange

Bore (mm)	Stroke range (mm)	A	B	FD	FT	FV	FX	FZ	L1	L2
12	5 to 30	49.4	32.4	4.5	5.5	25	45	55	13.5	3.5
16	5 to 30	53	36	4.5	5.5	30	45	55	13.5	3.5
20	5 to 50	57	38	6.6	8	39	48	60	14.5	4.5
25	5 to 50	59	39	6.6	8	42	52	64	15	5

*Refer to p.2.3-18 & 19 for rod end nut and optional brackets.

- CUJ
- CU
- CQS
- CQ2**
- RQ
- MU

Series CQ2W/CDQ2W

ø32 to ø50 With Auto Switch

For those without auto switches, refer to the dimension chart because their A, B and P dimensions will differ.

Standard (Through-hole)/CQ2WB, CDQ2WB

Both ends tapped: CQ2WA

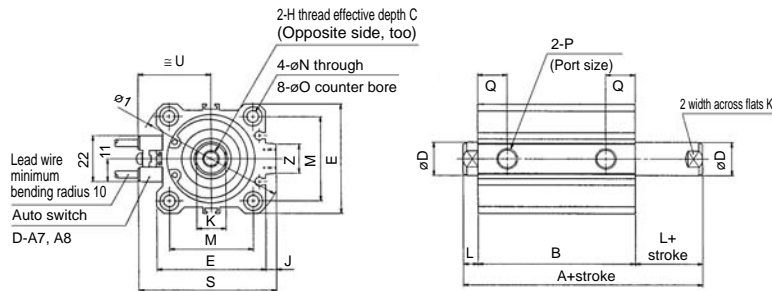
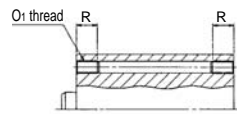

Both ends tapped(mm)

Bore (mm)	O ₁	R
32	M6 X 1.0	10
40	M6 X 1.0	10
50	M8 X 1.25	14

Rod end male thread

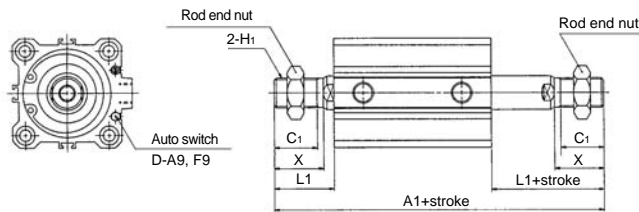

Rod end male thread

(mm)

Bore (mm)	Without auto switch			With auto switch		
	A			A		
	50st. or less	55 to 75	80 to 100	50st. or less	55 to 75	80 to 100
32	87.5+ stroke	172.5	197.5	97.5+ stroke	172.5	197.5
40	97+ stroke	182	207	107+ stroke	182	207
50	107.5+ stroke	192.5	217.5	117.5+ stroke	192.5	217.5

Built-in One-touch fitting/ø32 to ø50

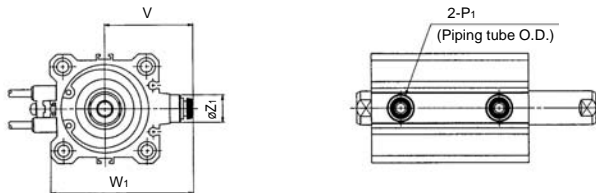

Bore (mm)	C ₁	H ₁	L ₁	X
32	20.5	M14 X 1.5	28.5	23.5
40	20.5	M14 X 1.5	28.5	23.5
50	26	M18 X 1.5	33.5	28.5

Auto switch shown above is D-A73 and D-A80. Refer to p.2.3-20 for auto switch mounting position and mounting height.

Built-in One-touch fitting (mm)

Bore size (mm)	Without auto switch		With auto switch		Z ₁	P ₁
	V	W ₁	V	W ₁		
32	38	60.5	36.5	59	13	6
40	42	68	40.5	66.5	13	6
50	50	82	50	82	16	8

Standard

(mm)

Bore (mm)	Without auto switch								With auto switch							
	A			B			P		A			B			P	
	50st. or less	55 to 75	80 to 100	50st. or less	55 to 75	80 to 100	5st.	10 to 100	50st. or less	55 to 75	80 to 100	50st. or less	55 to 75	80 to 100	5 to 100st.	
32	44.5+ stroke	129.5	154.5	30.5+ stroke	115.5	140.5	M5 X 0.8	1/8	54.5+ stroke	129.5	154.5	40.5+ stroke	115.5	140.5	1/8	
40	54+ stroke	139	164	40+ stroke	125	150	1/8	1/8	64+ stroke	139	164	50+ stroke	125	150	1/8	
50	56.5+ stroke	141.5	166.5	40.5+ stroke	125.5	150.5	1/4	1/4	66.5+ stroke	141.5	166.5	50.5+ stroke	125.5	150.5	1/4	

Bore (mm)	C	D	E	H	I	J	K	L	M	N	O	Q	S	U	Z
32	13	16	45	M8 X 1.25	60	4.5	14	7	34	5.5	9 Depth 7	12.5	58.5	31.5	14
40	13	16	52	M8 X 1.25	69	5	14	7	40	5.5	9 Depth 7	14	66	35	14
50	15	20	64	M10 X 1.5	86	7	17	8	50	6.6	11 Depth 8	14	80	41	19



Note) Dimensions of model with rubber bumper are same as standard as shown above.
* Refer to p.2.3-18 & 19 for rod end nut and optional brackets.

Compact Cylinder/Standard: Double Acting Double Rod Series **CDQ2W**

Foot/CQ2WL, CDQ2WL

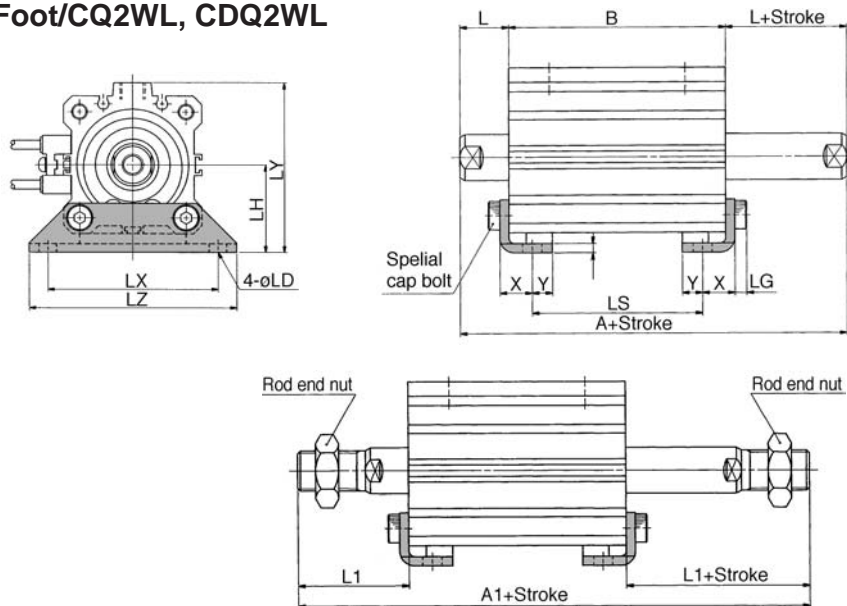

Rod end male thread (mm)

Bore (mm)	Without auto switch			With auto switch			L1
	A			B			
	50st. or less	55 to 75	80 to 100	50st. or less	55 to 75	80 to 100	
32	107.5 + stroke	192.5	217.5	117.5 + stroke	192.5	217.5	38.5
40	117 + stroke	202	227	127 + stroke	202	227	38.5
50	127.5 + stroke	212.5	237.5	137.5 + stroke	212.5	237.5	43.5

Foot

Bore (mm)	Stroke range (mm)	Without auto switch									With auto switch								
		A			B			LS			A			B			LS		
		50st. or less	55 to 75	80 to 100	50st. or less	55 to 75	80 to 100	50st. or less	55 to 75	80 to 100	50st. or less	55 to 75	80 to 100	50st. or less	55 to 75	80 to 100	50st. or less	55 to 75	80 to 100
32	5 to 50, 75, 100	64.5 + stroke	149.5	174.5	30.5 + stroke	115.5	140.5	14.5 + stroke	99.5	124.5	74.5 + stroke	149.5	174.5	40.5 + stroke	115.5	140.5	24.5 + stroke	99.5	124.5
40	5 to 50, 75, 100	74 + stroke	159	184	40 + stroke	125	150	24 + stroke	109	134	84 + stroke	159	184	50 + stroke	125	150	34 + stroke	109	134
50	10 to 50, 75, 100	76.5 + stroke	161.5	186.5	40.5 + stroke	125.5	150.5	17.5 + stroke	102.5	127.5	86.5 + stroke	161.5	186.5	50.5 + stroke	125.5	150.5	27.5 + stroke	102.5	127.5

(mm)											
Bore (mm)	L	LD	LG	LH	LT	LX	LY	LZ	X	Y	
32	17	6.6	4	30	3.2	57	57	71	11.2	5.8	
40	17	6.6	4	33	3.2	64	64	78	11.2	7	
50	18	9	5	39	3.2	79	78	95	14.7	8	

Flange/CQ2WF, CDQ2WF

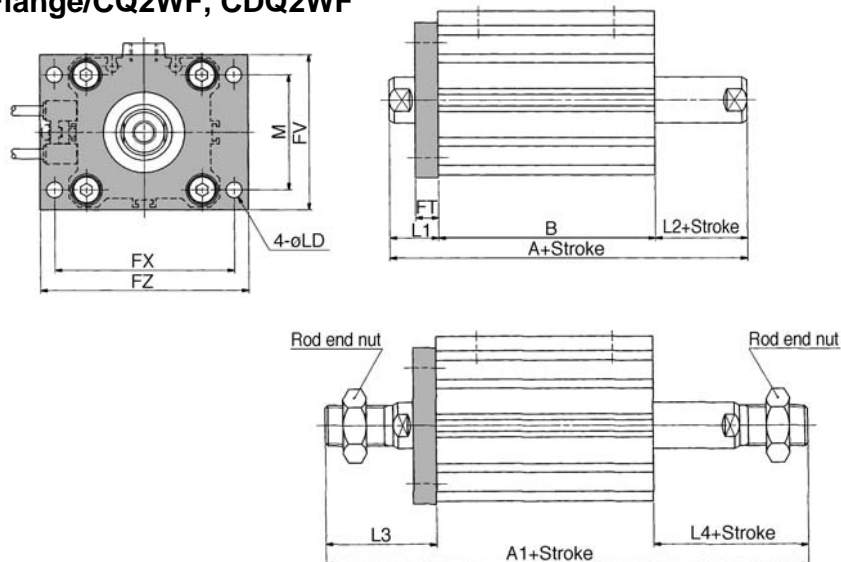

Rod end male thread (mm)

Bore (mm)	Without auto switch			With auto switch			L3	L4
	A1			A1				
	50st. or less	55 to 75	80 to 100	50st. or less	55 to 75	80 to 100		
32	97.5 + stroke	182.5	207.5	107.5 + stroke	182.5	207.5	38.5	28.5
40	107 + stroke	202.5	217	117 + stroke	192	217	38.5	28.5
50	117.5 + stroke	204	227.5	127.5 + stroke	202.5	227.5	43.5	33.5

Flange

Bore (mm)	Stroke range (mm)	Without auto switch									With auto switch										
		A			B			A			B			FD	FT	FV	FX	FZ	L1	L2	M
		50st. or less	55 to 75	80 to 100	50st. or less	55 to 75	80 to 100	50st. or less	55 to 75	80 to 100	50st. or less	55 to 75	80 to 100								
32	5 to 50, 75, 100	54.5 + stroke	139.5	164.5	30.5 + stroke	115.5	140.5	64.5 + stroke	139.5	164.5	40.5 + stroke	115.5	140.5	5.5	8	48	56	65	17	7	34
40	5 to 50, 75, 100	64 + stroke	149	174	40 + stroke	125	150	74 + stroke	149	174	50 + stroke	125	150	5.5	8	54	62	72	17	7	40
50	10 to 50, 75, 100	66.5 + stroke	151.5	176.5	40.5 + stroke	125.5	150.5	76.5 + stroke	151.5	176.5	50.5 + stroke	125.5	150.5	6.6	9	67	76	89	18	8	50

*Refer to p.2.3-18 & 19 for rod end nut and optional brackets.

Series CQ2W/CDQ2W

ø63 to ø100 With Auto Switch

For those without auto switches, refer to the dimension chart because their A and B dimensions will differ.

Both ends tapped: CQ2WA, CDQ2WA

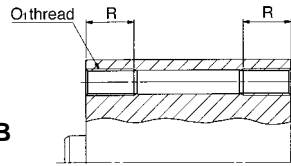

Both ends tapped (mm)

Bore (mm)	O1	R
63	M10 X 1.5	18
80	M12 X 1.75	22
100	M12 X 1.75	22

Standard (Through-hole)/CQ2WB, CDQ2WB

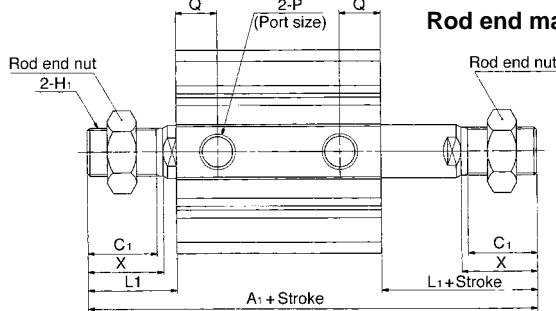
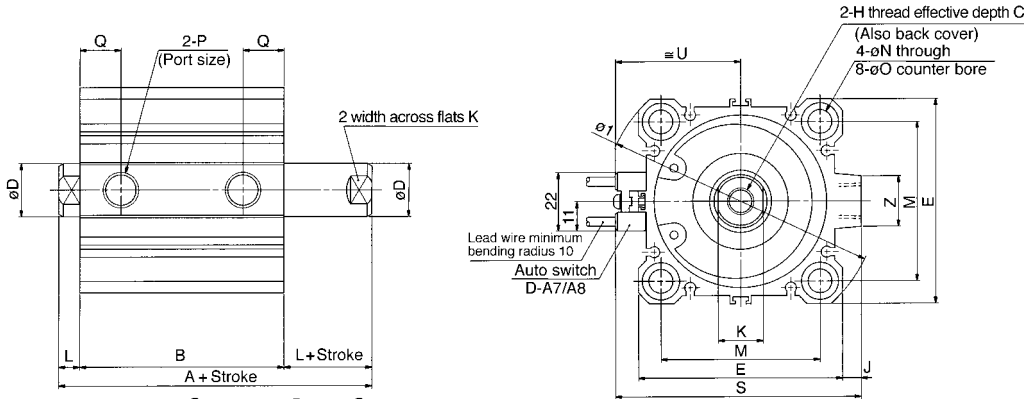

Rod end male thread

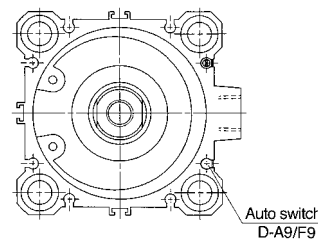

Male thread (mm)

Bore (mm)	Without auto switch			With auto switch		
	A1			A1		
	50st. or less	55 to 75	80 to 100	50st. or less	55 to 75	80 to 100
63	109 + stroke	194	219	119 + stroke	194	219
80	138 + stroke	223	248	148 + stroke	223	248
100	147.5 + stroke	232.5	257.5	157.5 + stroke	232.5	257.5

(mm)

Bore (mm)	C1	H1	L1	X
63	26	M18 X 1.5	33.5	28.5
80	32.5	M22 X 1.5	43.5	35.5
100	32.5	M26 X 1.5	43.5	35.5

Built-in One-touch fitting

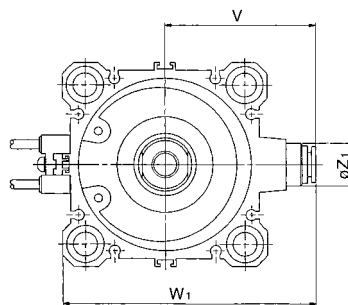
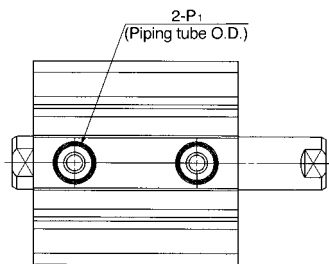

Built-in One-touch fitting (mm)

Bore (mm)	Z1	P1	V	W1
63	16	8	56.5	95

*Built-in One-touch fitting, ø32, 5stroke: Dimensions are same as 10stroke cylinder tube.

Auto switch shown above is D-A73 and D-A80. Refer to p.2.3-20 for auto switch mounting position and mounting height.

Standard

(mm)

Bore (mm)	Stroke range (mm)	Without auto switch						With auto switch					
		A			B			A			B		
		50st. or less	55 to 75	80 to 100	50st. or less	55 to 75	80 to 100	50st. or less	55 to 75	80 to 100	50st. or less	55 to 75	80 to 100
63	10 to 50, 75, 100	58+ stroke	143	168	42+ stroke	127	152	68+ stroke	143	168	52+ stroke	127	152
80	10 to 50, 75, 100	71+ stroke	156	181	51+ stroke	136	161	81+ stroke	156	181	61+ stroke	136	161
100	10 to 50, 75, 100	84.5+ stroke	169.5	194.5	60.5+ stroke	145.5	170.5	94.5+ stroke	169.5	194.5	70.5+ stroke	145.5	170.5

(mm)

Bore (mm)	C	D	E	H	I	J	K	L	M	N	O	P	Q	S	U	W
32	15	20	77	M10 X 1.5	103	7	17	8	60	9	14 Depth 10.5	1/4	15.5	93	47.5	19
40	21	25	98	M16 X 2.0	132	6	22	10	77	11	17.5 Depth 13.5	3/8	18	112.5	57.5	26
50	27	30	117	M20 X 2.5	156	6.5	27	12	94	11	17.5 Depth 13.5	3/8	22	132.5	67.5	26

Note 1) Dimensions of model with rubber bumper are same as standard shown above.
* Refer to p.2.3-18 & 19 for rod end nut and optional brackets.

Compact Cylinder/Standard: Double Acting Double Rod **Series CQ2W**

Foot/CQ2WL, CDQ2WL

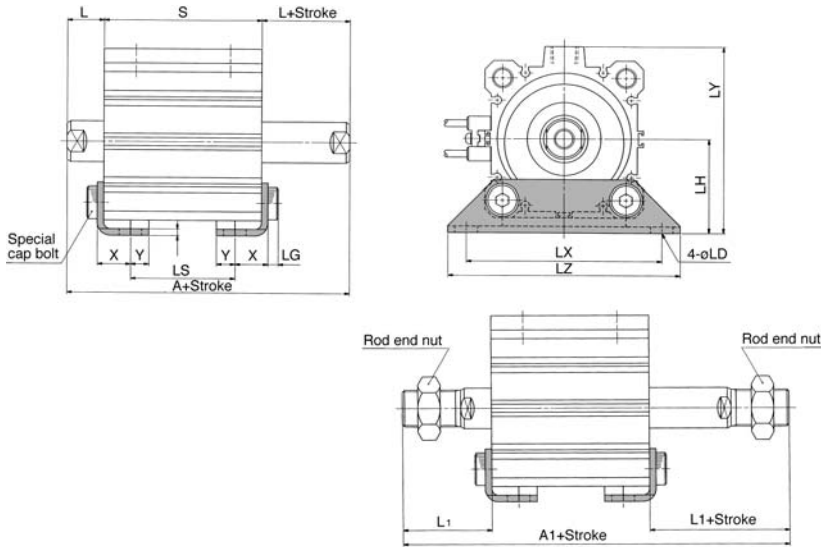

Rod end male thread

Bore (mm)	Without auto switch						With auto switch						L1
	A1			A1			A1			A1			
	50st or less	55 to 75	80 to 100	50st or less	55 to 75	80 to 100	50st or less	55 to 75	80 to 100	50st or less	55 to 75	80 to 100	
63	129+ Stroke	214	239	139+ Stroke	214	239	129+ Stroke	214	239	139+ Stroke	214	239	43.5
80	158+ Stroke	243	268	168+ Stroke	243	268	148+ Stroke	243	268	158+ Stroke	243	268	53.5
100	187.5+ Stroke	252.5	277	197.5+ Stroke	252.5	277.5	177.5+ Stroke	252.5	277.5	187.5+ Stroke	252.5	277.5	53.5

Foot

(mm)

Bore (mm)	Stroke range (mm)	Without auto switch									With auto switch								
		A			B			LS			A			B			LS		
		50st or less	55 to 75	80 to 100	50st or less	55 to 75	80 to 100	50st or less	55 to 75	80 to 100	50st or less	55 to 75	80 to 100	50st or less	55 to 75	80 to 100	50st or less	55 to 75	80 to 100
63	5 to 50, 75, 100	78+ Stroke	163	188	42+ Stroke	127	152	16+ Stroke	101	126	88+ Stroke	163	188	52+ Stroke	127	152	26+ Stroke	101	126
80	5 to 50, 75, 100	91+ Stroke	176	201	51+ Stroke	136	161	21+ Stroke	106	131	101+ Stroke	176	201	61+ Stroke	136	161	31+ Stroke	106	131
100	10 to 50, 75, 100	104.5+ Stroke	189.5	214.5	60.5+ Stroke	145.5	170.5	26.5+ Stroke	111.5	136.5	114.5+ Stroke	189.5	214.5	70.5+ Stroke	145.5	170.5	36.5+ Stroke	111.5	136.5

mm

Bore (mm)	L	LD	LG	LH	LT	LX	LY	LZ	X	Y
63	18	11	5	46	3.2	95	91.5	113	16.2	9
80	20	13	7	59	4.5	118	114	140	19.5	11
100	22	13	7	71	6	137	136	162	23	12.5

Flange/CQ2WF, CDQ2WF

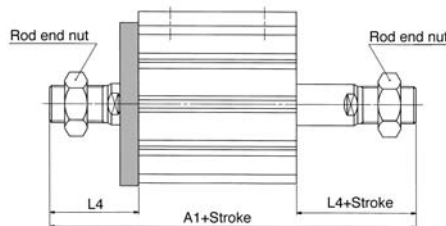
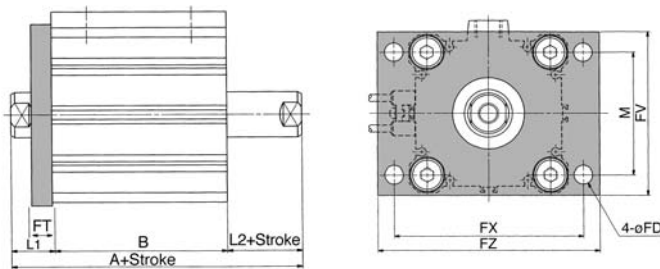

Rod end male thread

(mm)

Bore (mm)	Without auto switch						With auto switch						L3	L4
	A1			A1			A1			A1				
	50st or less	55 to 75	80 to 100	50st or less	55 to 75	80 to 100	50st or less	55 to 75	80 to 100	50st or less	55 to 75	80 to 100		
63	119+ Stroke	204	229	129+ Stroke	204	229	119+ Stroke	204	229	129+ Stroke	204	229	43.5	33.5
80	148+ Stroke	233	258	158+ Stroke	233	258	148+ Stroke	233	258	158+ Stroke	233	258	53.5	43.5
100	187.5+ Stroke	242.5	267.5	187.5+ Stroke	242.5	267.5	167.5+ Stroke	242.5	267.5	187.5+ Stroke	242.5	267.5	53.5	43.5

Flange

(mm)

Bore (mm)	Stroke range (mm)	Without auto switch									With auto switch									FD	FT	FV	FX	FZ	L1	L2	M
		A			B			A			B																
		50st or less	55 to 75	80 to 100	50st or less	55 to 75	80 to 100	50st or less	55 to 75	80 to 100	50st or less	55 to 75	80 to 100	50st or less	55 to 75	80 to 100											
32	10 to 50, 75, 100	68+ Stroke	153	178	42+ Stroke	127	152	78+ Stroke	153	178	52+ Stroke	127	152	9	9	80	92	108	18	8	60						
40	10 to 50, 75, 100	81+ Stroke	166	191	51+ Stroke	136	161	91+ Stroke	166	191	61+ Stroke	136	161	11	11	99	116	134	20	10	77						
50	10 to 50, 75, 100	94.5+ Stroke	179.5	204.5	60.5+ Stroke	145.5	170.5	104.5+ Stroke	179.5	204.5	70.5+ Stroke	145.5	170.5	11	11	117	136	154	22	12	94						

CUJ

CU

CQS

CQ2

RQ

MU

Compact Cylinder/Standard: Single Acting Spring Return/Extend

Series CQ2

ø12, ø16, ø20, ø25, ø32, ø40, ø50

How to Order

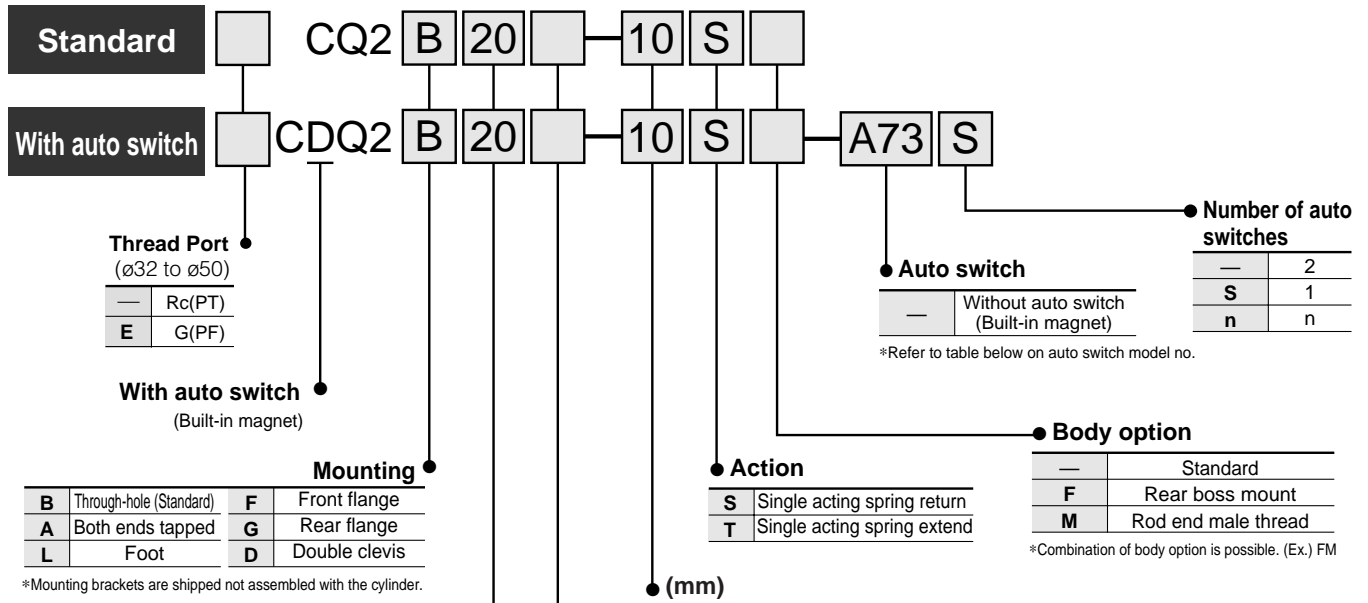

Refer to standard stroke table on p.2.3-39.

Bore size

12	12mm
16	16mm
20	20mm
25	25mm
32	32mm
40	40mm
50	50mm

Piping

—	Screw-in piping
F	Built-in One touch fitting (1)

Note 1) Built-in One-touch fitting: Bore size ø32 to ø50.

Mounting Bracket Part No.

Bore size (mm)	Foot ⁽²⁾	Flange	Double clevis ⁽⁴⁾
12	CQ-L012	CQ-F012	CQ-D012
16	CQ-L016	CQ-F016	CQ-D016
20	CQ-L020	CQ-F020	CQ-D020
25	CQ-L025	CQ-F025	CQ-D025
32	CQ-L032	CQ-F032	CQ-D032
40	CQ-L040	CQ-F040	CQ-D040
50	CQ-L050	CQ-F050	CQ-D050

Note 2) When ordering foot brackets, 2pcs. should be ordered for each cylinder.

Note 3) The parts included with each mounting bracket are as follows.

Foot, flange/Body mounting bolts
Double clevis/Clevis pin, C shaped snap ring for axis, Body mounting bolt

Note 4) Clevis pin and snap ring is included for double clevis.

Applicable Auto Switches/Refer to p.5.3-2 for detail specifications on auto switches.

Style	Special function	Electrical entry	Indicator	Wiring (Output)	Load voltage		Rail mounting		Direct mounting		Lead wire (m)*				Applicable load						
					DC	AC	ø12 to ø100		ø32 to ø100		0.5 (-)	3 (L)	5 (Z)	None (N)							
							Perp.	In-line	Perp.	In-line											
Reed switch	—	Grommet	Yes	3 wire (Equiv. to NPN)	—	5V	—	A76H	A96V	A96	●	●	○	—	IC						
								A72	A72H	—	●	●	—	—	—						
								A73	A73H	—	●	●	—	—	—						
								—	—	A93V	A93	●	●	—	—	—					
								—	—	—	—	●	●	—	—	—					
								24V	5V, 12V	≤100V	A80	A80H	A90V	A90	●	●	—	—	—	—	IC
											—	—	—	—	●	●	—	—	—	—	
											—	—	—	—	●	●	—	—	—	—	
											—	—	—	—	●	●	—	—	—	—	
											—	—	—	—	●	●	—	—	—	—	
Solid state switch	—	Grommet	Yes	3 wire (NPN)	—	5V, 12V	—	F7NV	F79	—	—	●	●	○	—	IC					
								—	—	F9NV	F9N	●	●	—	—	—					
								F7PV	F7P	—	—	●	●	—	—	—					
								—	—	F9PV	F9P	●	●	—	—	—					
								F7BV	J79	—	—	●	●	○	—	—					
								24V	5V, 12V	—	—	—	F9BV	F9B	●	●	—	—	—		
											—	—	—	—	●	●	—	—	—		
											J79C	—	—	—	●	●	—	—	—		
											F7N WV	F79W	—	—	●	●	○	—	—	IC	
											—	—	F9N WV	F9N W	●	●	○	—	—	—	
Grommet	Diagnostic (2 colour)	Yes	3 wire (NPN)	—	5V, 12V	—	—	F7PW	—	—	—	●	●	○	—	IC					
							—	—	F9PWV	F9PW	●	●	○	—	—						
							—	—	—	—	●	●	—	—	—						
							F7B WV	J79W	F9B WV	F9B W	●	●	○	—	—						
							—	—	—	—	●	●	○	—	—						
Grommet	Water resistance (2 colour)	—	3 wire (NPN)	—	5V, 12V	—	—	F7BA	—	F9BA	—	●	●	○	—	—					
							—	F7NT	—	—	—	●	●	○	—	—					
							—	F79F	—	—	—	●	●	○	—	—					
Grommet	Latch with diagnostic output (2 colour)	—	4 wire (NPN)	—	—	—	—	F7LF	—	—	—	●	●	○	—	—					
							—	—	—	—	—	—	—	—	—	—					

*Lead wire length 0.5m..... — (Example) A80C 5m..... Z (Example) A80CZ
3m..... L (Example) A80CL None..... N (Example) A80CN

*Solid state switches marked with "O" are manufactured upon receipt of order.

Compact Cylinder/Standard: Single Acting Spring Return/Extend **Series CQ2**



Model

Bore size (mm)		12	16	20	25	32	40	50	
Pneumatic	Mounting	Through-hole (Standard)	●	●	●	●	●	●	
		Both ends tapped	●	●	●	●	●	●	
	Built-in magnet		●	●	●	●	●	●	
	Piping	Screw-in style	M5 X 0.8	M5 X 0.8	M5 X 0.8	M5 X 0.8	M5 X 0.8 ⁽¹⁾ 1/8	1/8	1/4
		With built-in One-touch fitting	—	—	—	—	ø6/4 ⁽²⁾	ø6/4	ø8/6
	Rod end male thread		●	●	●	●	●	●	●
Rear boss mount		●	●	●	●	●	●	●	

Note 1) Without auto switch: 5stroke type=M5 X 0.8

Note 2) With built-in fitting: Dimensions of bore size ø32 5stroke are same as 10stroke model.

Specifications

Model	Pneumatic (Non-lube)
Fluid	Air
Proof pressure	1.5MPa
Max. operating pressure	1.0MPa
Ambient and fluid temperature	Without auto switch: -10°C to 70°C (No freezing)
	With auto switch: -10°C to 60°C (No freezing)
Rubber bumper	None
Rod end thread	Female thread
Tolerance of rod end thread	JIS class 2
Tolerance of stroke length	+1.0 0
Mounting	Through-hole
Piston speed	50 to 500mm/s

JIS symbol

Single acting/
spring return

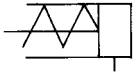

Single acting/
spring extend

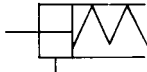

Made to Order

Refer to p.5.4-1 for common made to order specifications and p.5.4-79 for individual specifications.



Precautions

- Be sure to read before handling.
- Refer to p.0-39 to 0-46 for Safety Instructions and common precautions.

Caution

Snap Ring Installation/Removal

- ① For installation and removal, use an appropriate pair of pliers (tool for installing a C snap ring).
- ② Exercise caution even when using an appropriate pair of pliers (tool for installing a C snap ring), because of the possibility of the snap ring becoming detached from the tip of the pliers (tool for installing a C snap ring) and flying away, which could injure humans or damage the peripheral equipment. After installing the snap ring, make sure that it is placed securely in the ring groove before supplying air.

Standard Stroke

Unit: mm

Bore size (mm)	Standard stroke
12, 16, 20 25, 32, 40	5, 10
50	10, 20

Minimum Operating Pressure

Unit: MPa

Bore size (mm)	Single acting (Spring return, Spring extend)
12	0.25
16	0.25
20	0.18
25	0.18
32	0.17
40	0.15
50	0.13

Theoretical Force

Unit: N

Action	Bore size (mm)	Operating pressure (MPa)		
		0.3	0.5	0.7
Spring return	12	21	44	66
	16	45	86	126
	20	79	142	205
	25	126	224	323
	32	211	372	533
	40	338	589	841
Spring extend	50	535	928	1316
	12	14	31	48
	16	24	54	85
	20	71	118	165
	25	113	189	264
	32	181	302	422
40	317	528	739	
50	495	825	1150	

Refer to p.5.6-3 for spring force.

Allowable Kinetic Energy

Unit: J

Bore size (mm)	12	16	20	25	32	40	50	63	80	100
Kinetic energy	0.022	0.038	0.055	0.09	0.15	0.26	0.46	0.77	1.36	2.27

CUJ

CU

CQS

CQ2

RQ

MU

Series CQ2

Weight

Unit: g

Action	Bore size (mm)	Cylinder stroke (mm)			
		5	10	15	20
Spring return	12	29	35	—	—
	16	42	51	—	—
	20	63	76	—	—
	25	87	101	—	—
	32	131	152	—	—
	40	206	229	—	—
	50	—	369	—	441
Spring extend	12	29	35	—	—
	16	43	50	—	—
	20	67	78	—	—
	25	92	104	—	—
	32	141	158	—	—
	40	216	235	—	—
	50	—	399	—	460

Option Weights

Unit: g

Bore size (mm)	12	16	20	25	32	40	50
Both ends tapped	2	2	6	6	6	6	6
Rod end male thread	Male thread	1.5	3	6	12	26	53
	Nut	1	2	4	8	17	32
Rear boss mount	0.7	1.3	2	3	5	7	13
One-touch fitting	—	—	—	—	6	6	10.5
Foot	55	67	164	186	143	155	243
Front flange (including bolt)	57	69	139	161	180	214	373
Rear flange (including bolt)	54	65	133	152	165	198	348
Double clevis (including pin, snap ring, bolt)	32	39	88	123	151	196	393

Calculation example: CQ2D32-10SM

- Cylinder weight: CQ2B32-10S 152g
- Option weight: Both ends tapped 6g
- Rod end male thread 43g
- Double clevis 151g
- 352g

Auto Switch Mounting Bracket Part No.

Bore size (mm)	Part No.	Note	Applicable switch	
			Reed switch	Solid state switch
12, 16 20, 25	BQ-1	<ul style="list-style-type: none"> • Switch mounting screw (M3 X 0.5 X 8 ℓ) • Square nut 	D-A7, A8 D-A73C, A80C D-A7□H, A80H D-A79W	D-F7□, J79 D-F7□V D-J79C D-F7□W, J79W D-F7□WV D-F7BAL D-F7□F D-F7NTL
32, 40 50	BQ-2	<ul style="list-style-type: none"> • Switch mounting screw (M3 X 0.5 X 10 ℓ) • Switch spacer • Switch mounting nut 		



[Stainless steel mounting bolt set]

The set of stainless steel mounting screws (with nuts) described below is available and can be used depending on the operating environment.

(The spacers for auto switches must be ordered separately, as they are not included.)

BBA2: For D-A7/A8/F7/J7

The stainless steel bolts described above are used when the D-F7BAL switch is shipped mounted on a cylinder. When the switches are shipped as individual parts, the BBA2 set is included.

Mounting Bolt for CQ2

Special long bolt for through-hole mounting is available as option.

How to Order: Specify the required bolts

Example) Bolt M3 X 25 ℓ 4 pcs.

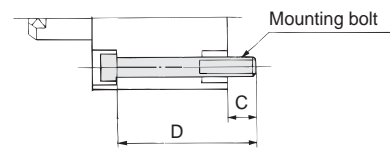
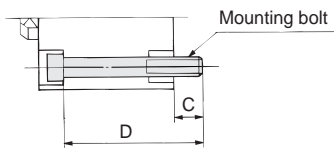

Spring return

Model	C	D	Mounting bolt
CQ2B12-5S -10S	6.5	25	M3 X 25 ℓ
		30	X 30 ℓ
CQ2B16-5S -10S	5	25	M3 X 25 ℓ
		30	X 30 ℓ
CQ2B20-5S -10S	7.5	25	M5 X 25 ℓ
		30	X 30 ℓ
CQ2B25-5S -10S	9.5	30	M5 X 30 ℓ
		35	X 35 ℓ
CQ2B32-5S -10S	9	30	M5 X 30 ℓ
		35	X 35 ℓ
CQ2B40-5S -10S	7.5	35	M5 X 35 ℓ
		40	X 40 ℓ
CQ2B50-10S -20S	12.5	45	M6 X 45 ℓ
		55	X 55 ℓ

Spring extend

Model	C	D	Mounting bolt
CQ2B12-5T -10T	6.5	25	M3 X 25 ℓ
		30	X 30 ℓ
CQ2B16-5T -10T	5	25	M3 X 25 ℓ
		30	X 30 ℓ
CQ2B20-5T -10T	7.5	25	M5 X 25 ℓ
		30	X 30 ℓ
CQ2B25-5T -10T	9.5	30	M5 X 30 ℓ
		35	X 35 ℓ
CQ2B32-5T -10T	9	30	M5 X 30 ℓ
		35	X 35 ℓ
CQ2B40-5T -10T	7.5	35	M5 X 35 ℓ
		40	X 40 ℓ
CQ2B50-10T -20T	12.5	45	M6 X 45 ℓ
		55	X 55 ℓ

Compact Cylinder/Standard: Single Acting Spring Return/Extend **Series CQ2W**

Construction

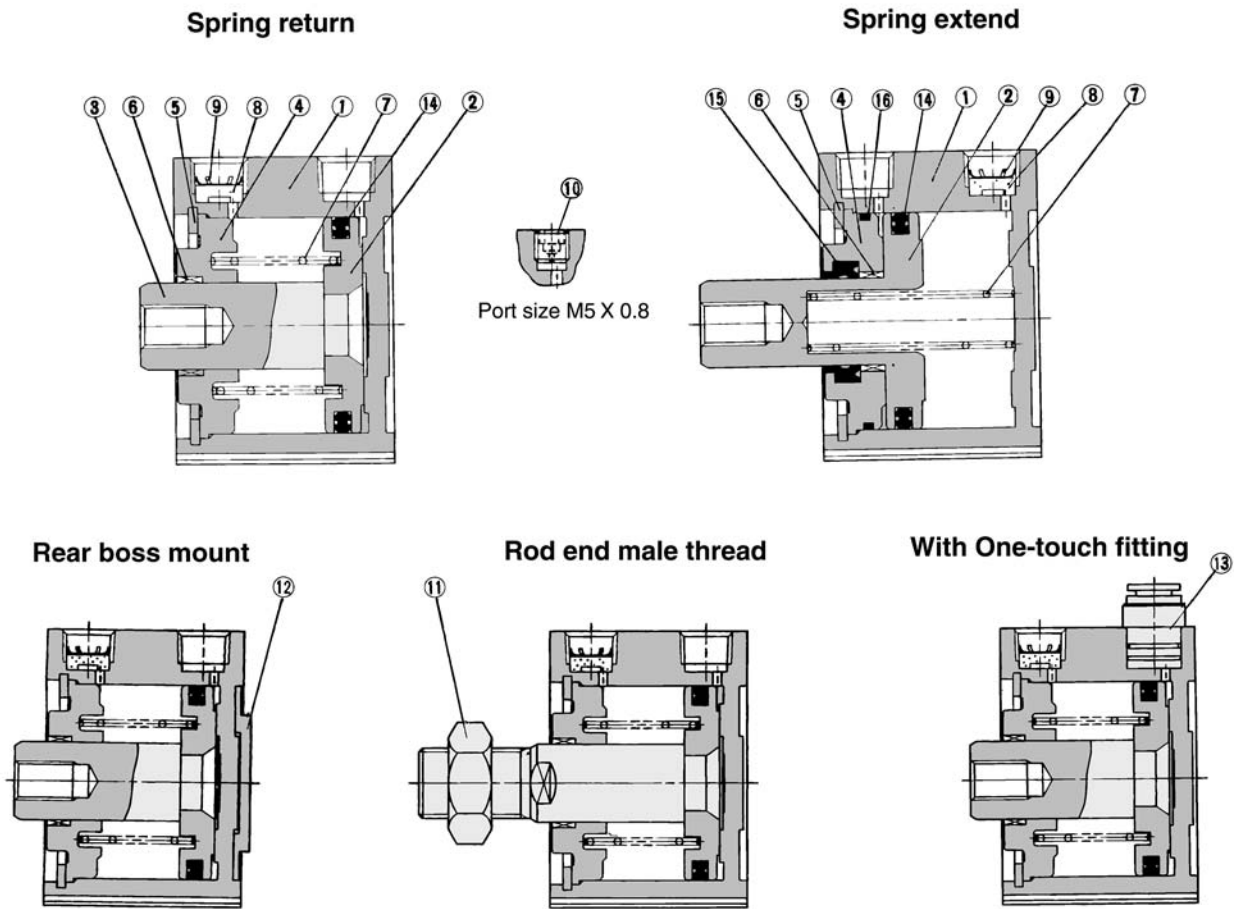

Component Parts

No.	Description	Material	Note
①	Cylinder tube	Aluminum alloy	Hard anodized
②*	Piston	Aluminum alloy	Chromated
		Stainless steel	ø12 to ø25
③	Piston rod	Carbon steel	ø32 to ø50, Hard chrome plated
		Aluminum bearing alloy	ø12 to ø40, Anodized
④	Collar	Aluminum alloy casting	ø50, Chromated, coated
⑤	Snap ring	Carbon tool steel	Phosphate coating
⑥	Bushing	Lead bronze casting	Used for only ø50
⑦	Return spring	Piano wire	Zinc chromated
⑧	Bronze element	Sintered metal BC	In case of port size
⑨	Snap ring	Carbon tool steel	Rc(PT)1/8, 1/4
⑩	Plug with fixed orifice	Alloy steel	In case of port size M5 X 0.8
⑪	Rod end nut	Carbon steel	Nickel plated
⑫	Guide boss ring	Aluminum alloy	ø20 to ø50, Anodized
⑬	One-touch fitting	—	ø32 to ø50

* Spring extend type (T type) piston and piston rod are combined. (Stainless steel)

Component Parts

No.	Description	Material	Note
⑭	Piston seal	NBR	
⑮	Rod seal	NBR	
⑯	Gasket	NBR	

Replacement Parts: Seal Kits

Series	Bore size	Kit No.	Contents
Pneumatic	12	CQ2B12-S-PS	Kits include items ⑭, ⑮ and ⑯ from the table above.
	16	CQ2B16-S-PS	
	20	CQ2B20-S-PS	
	25	CQ2B25-S-PS	
	32	CQ2B32-S-PS	
	40	CQ2B40-S-PS	
	50	CQ2B50-S-PS	

* Seal kits consist of items ⑭, ⑮ and ⑯ contained in one kit, and can be ordered using the order number for each respective tube bore size.

Copper Free

20 — CQ2B Bore size — Stroke $\frac{S}{T}(M)$
 • Copper free • ø12, ø16, ø20, ø25, ø32, ø40, ø50

To eliminate influences of copper ions or halogen ions during CRT manufacturing processes, copper and fluorine materials are not used as component parts.

Specifications

Action	Single acting single rod
Cylinder bore size	ø12, ø16, ø20, ø25, ø32, ø40, ø50,
Proof pressure	1.5MPa
Max. operating pressure	1.0MPa
Rubber bumper	None
Piping	Screw-in piping
Piston speed	50 to 500mm/s
Mounting	Through-hole
Auto switch	Mountable

Series CDQ2 Auto Switch Specifications



Minimum Strokes for Auto Switch Mounting

(mm)

Number of auto switches	D-F7□V D-J79C D-F9□V	D-A7□ D-A80 D-A73C D-A80C D-A9□V	D-F7□WV D-F9□WV	D-A7□H D-A80H D-F7□ D-J79 D-F9B D-F9P D-F9□W	D-A79W	D-F7□W D-J79W D-F7BAL D-F79F D-F9BAL	D-A9□ D-F9N
	1	5	5	10	15	15	20
2	5	10	15	15	20	20	10

Weight

Unit: g

Action	Bore size (mm)	Cylinder stroke (mm)			
		5	10	15	20
Spring return	12	48	54	-	-
	16	74	83	-	-
	20	109	123	-	-
	25	146	162	-	-
	32	190	211	-	-
	40	282	305	-	-
	50	-	487	-	559
Spring extend	12	53	70	-	-
	16	73	82	-	-
	20	122	133	-	-
	25	160	175	-	-
	32	200	217	-	-
	40	292	311	-	-
50	-	517	-	578	

Option Weights

Unit: g

Bore size (mm)	Option Weights							
	12	16	20	25	32	40	50	
Both ends tapped	1	1	3	3	6	6	6	
Rod end male thread	Male thread	1.5	3	6	12	26	27	
	Nut	1	2	4	8	17	17	
Rear boss mount	0.7	1.3	2	3	5	7	13	
One-touch fitting	-	-	-	-	6	6	10.5	
Foot (including bolt)	49	62	147	169	143	155	243	
Front flange (including bolt)	54	67	131	153	180	214	373	
Rear flange (including bolt)	52	63	124	144	165	198	348	
Double clevis (including pin, snap ring, bolt)	29	35	78	114	151	196	393	

Calculation example) CDQ2D32-10SM

- Cylinder weight: CDQ2B32-10S 211g
- Option weight: Both ends tapped 6g
- Rod end male thread 43g
- Double clevis 151g

If auto switches are to be installed, the weight that corresponds to the number of auto switches and mounting brackets to be used must be added.

Weight/Auto Switch Mounting Bracket

Part No.	Applicable bore size	Weight g
BQ-1	ø12 to ø25	1.5
BQ-2	ø32 to ø50	1.5

* Refer to p.5.3-75 for auto switch weight.

Construction

Spring return

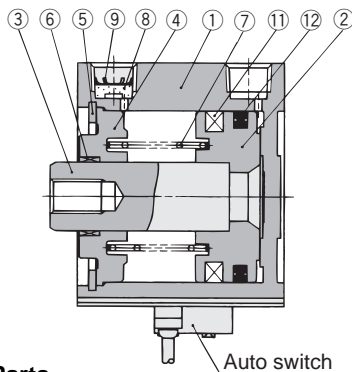

Spring extend

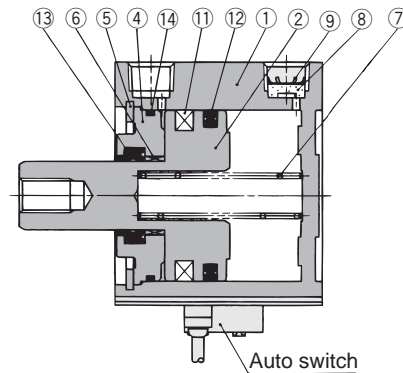

Port size M5 X 0.8

Component Parts

No.	Description	Material	Note
①	Cylinder tube	Aluminum alloy	Hard anodized
②	Piston	Aluminum alloy	Chromated
③	Piston rod	Stainless steel	ø12 to ø25
		Carbon steel	ø32 to ø50, Hard chrome plated
④	Collar	Aluminum bearing alloy	ø12 to ø40, Anodized
		Aluminum alloy casting	ø50, Chromated, coated
⑤	Snap ring	Carbon tool steel	Phosphate coating
⑥	Bushing	Lead bronze casting	Used for only ø50
⑦	Return spring	Piano wire	Zinc chromated
⑧	Bronze element	Sintered metal BC	In case of port size
⑨	Snap ring	Carbon tool steel	1/8, 1/4
⑩	Plug with fixed orifice	Lead bronze casting	In case of port size M5 X 0.8
⑪	Magnet	-	-

* Piston and piston rod of spring extend type (T type) bore size ø20 or larger are combined. (Stainless steel)

No.	Description	Mat'l	Note
⑫	Piston seal	NBR	
⑬	Rod seal	NBR	
⑭	Gasket	NBR	

Replacement Parts: Seal Kits

Series	Bore size	Kit No.	Contents
Pneumatic	12	CQ2B12-PS	Kits include items ⑫, ⑬ and ⑭ from the table above.
	16	CQ2B16-PS	
	20	CQ2B20-PS	
	25	CQ2B25-PS	
	32	CQ2B32-PS	
	40	CQ2B40-PS	
	50	CQ2B50-PS	

* Seal kit consist of item ⑫, ⑬ and ⑭ contained in one kit, and can be ordered using the order number for each respective tube bore size.

Compact Cylinder/Standard: Single Acting Spring Return/Extend **Series CDQ2**

Mounting Bolt for CDQ2 with Auto Switch

Special long bolt for through hole mounting is available as option.

How to Order: Specify the required bolts.
Example) Bolt M3 X 35 ℓ 2 pcs.

Spring return

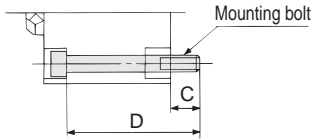

Spring extend

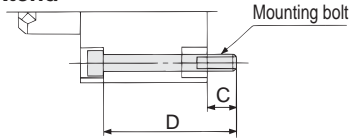

Spring return

Model	C	D	Mounting bolt
CDQ2B12-5S	5.5	35	M3 X 35 ℓ
		40	X 40 ℓ
CDQ2B16-5S	8	40	M3 X 40 ℓ
		45	X 45 ℓ
CDQ2B20-5S	10.5	40	M5 X 40 ℓ
		45	X 45 ℓ
CDQ2B25-5S	9.5	40	M5 X 40 ℓ
		45	X 45 ℓ
CDQ2B32-5S	9	40	M5 X 40 ℓ
		45	X 45 ℓ
CDQ2B40-5S	7.5	45	M5 X 45 ℓ
		50	X 50 ℓ
CDQ2B50-10S	12.5	55	M6 X 55 ℓ
		65	X 65 ℓ

Spring extend

Model	C	D	Mounting bolt
CDQ2B12-5T	6.1	40	M3 X 40 ℓ
		45	X 45 ℓ
CDQ2B16-5T	8	40	M3 X 40 ℓ
		45	X 45 ℓ
CDQ2B20-5T	10.5	40	M5 X 40 ℓ
		45	X 45 ℓ
CDQ2B25-5T	9.5	40	M5 X 40 ℓ
		45	X 45 ℓ
CDQ2B32-5T	9	40	M5 X 40 ℓ
		45	X 45 ℓ
CDQ2B40-5T	7.5	45	M5 X 45 ℓ
		50	X 50 ℓ
CDQ2B50-10T	12.5	55	M6 X 55 ℓ
		65	X 65 ℓ

Auto Switch Mounting Position (at Stroke End) and Mounting Height

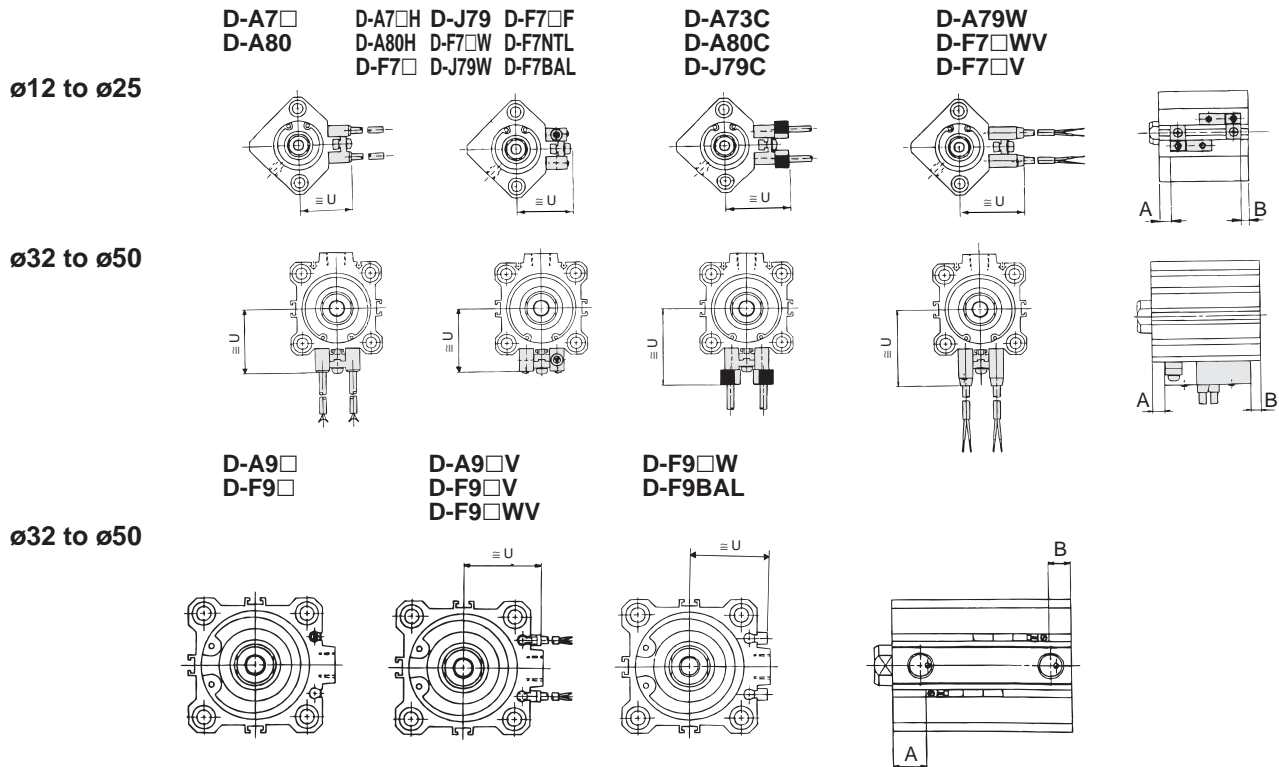

- CUJ
- CU
- CQS
- CQ2**
- RQ
- MU

Auto Switch Mounting Position

Bore (mm)	D-A7□ D-A80		D-A7□H D-A80H D-A73C D-A80C D-F7□ D-J79 D-F7□V D-J79C		D-A79W		D-F7BAL D-F7□W D-F7□F D-J79W D-F7□WV		D-A9□ D-A9□V		D-F9□ D-F9□V		D-F9□W D-F9□WV D-F9BAL	
	A	B	A	B	A	B	A	B	A	B	A	B	A	B
12	4.5	5.5 (10)	5	6 (10.5)	2	3 (7.5)	9	10 (4.5)	—	—	—	—	—	—
16	7.5 (5.5)	5 (7)	8 (6)	5.5 (7.5)	5 (3)	2.5 (4.5)	12 (10)	9.5 (11.5)	—	—	—	—	—	—
20	7.5	6.5	8	7	5	4	12	11	—	—	—	—	—	—
25	7.5	7	8	7.5	5	4.5	12	11.5	—	—	—	—	—	—
32	9	6	9.5	6.5	6.5	3.5	13.5	10.5	8	5	12	9	11	8
40	13	8.5	13.5	9	10.5	6	17.5	13	12	7.5	16	11.5	15	10.5
50	11	11.5	11.5	12	8.5	9	15.5	16	10	10.5	14	14.5	13	13.5

Auto Switch Mounting Height

										(mm)	
D-A7□ D-A80	D-A7□H D-A80H D-F7□ D-J79 D-F7□W D-J79W D-F7BAL D-F7□F D-F7NTL		D-A73C D-A80C	D-F7□V D-F7□WV	D-J79C	D-A79W	D-A9□V	D-F9□V D-F9□WV	D-F9□W D-F9BAL		
	U	U								U	U
19.5	20.5	26.5	23	26	22	—	—	—	—	—	
22.5	23.5	29.5	26	29	25	—	—	—	—	—	
24.5	25.5	31.5	28	31	27	—	—	—	—	—	
27.5	28.5	34.5	31	34	30	—	—	—	—	—	
31.5	32.5	38.5	35	38	34	27	29	26.5	—	—	
35	36	42	38.5	41.5	37.5	30.5	32.5	30	—	—	
41	42	48	44.5	47.5	43.5	36.5	38.5	36	—	—	

Series CQ2

ø12 to ø25 Spring Return Without Auto Switch

Standard (Through-hole): CQ2B

Both ends tapped: CQ2A

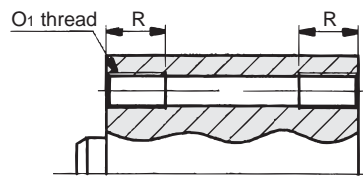

Both ends tapped (mm)

Bore (mm)	O1	R
12	M4 X 0.7	7
16	M4 X 0.7	7
20	M6 X 1.0	10
25	M6 X 1.0	10

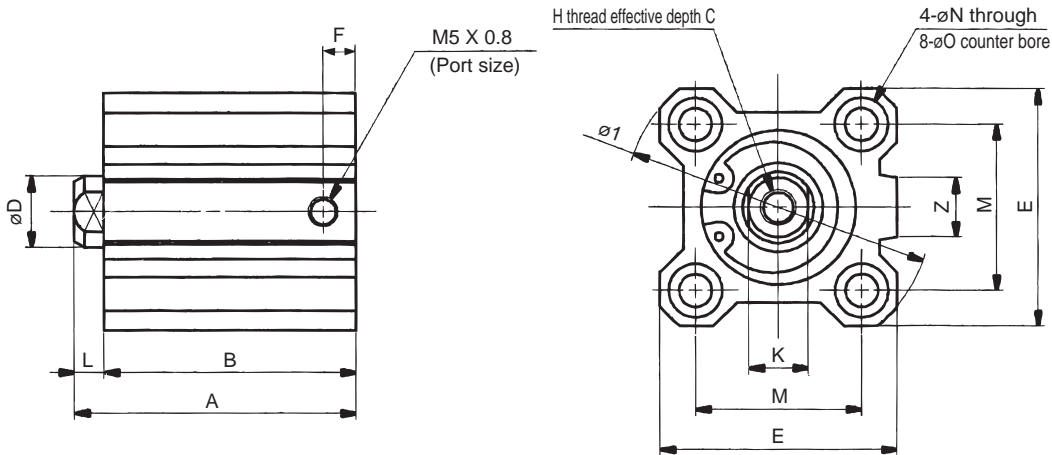

Rear boss mount

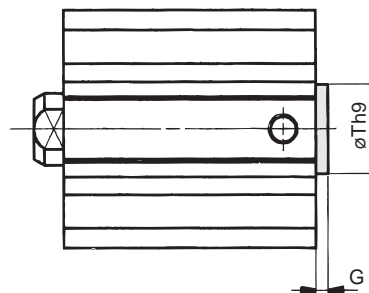

Rear boss mount (mm)

Bore (mm)	G	Th9
12	1.5	15 ⁰ _{-0.043}
16	1.5	20 ⁰ _{-0.052}
20	2	13 ⁰ _{-0.043}
25	2	15 ⁰ _{-0.043}

Rod end male thread

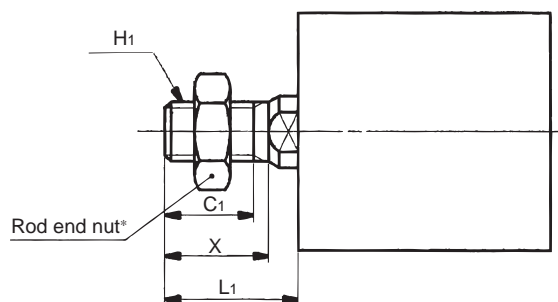

Rod end male thread (mm)

Bore (mm)	C1	X	H1	L1
12	9	10.5	M5 X 0.8	14
16	10	12	M6 X 1.0	15.5
20	12	14	M8 X 1.25	18.5
25	15	17.5	M10 X 1.25	22.5

Standard

Bore (mm)	A		B		C	D	E	F	H	I	K	L	M	N	O	Z
	5st	10st	5st	10st												
12	25.5	30.5	22	27	6	6	25	5	M3 X 0.5	32	5	3.5	15.5	3.5	6.5 Depth 3.5	-
16	27	32	23.5	28.5	8	8	29	5.5	M4 X 0.7	38	6	3.5	20	3.5	6.5 Depth 3.5	10
20	29	34	24.5	29.5	7	10	36	5.5	M5 X 0.8	47	8	4.5	25.5	5.5	9 Depth 7	10
25	32.5	37.5	27.5	32.5	12	12	40	5.5	M6 X 1.0	52	10	5	28	5.5	9 Depth 7	10

* Refer to p.2.3-18 & 19 for rod end nut and optional brackets.

Compact Cylinder/Standard: Single Acting Spring Return/Extend **Series CQ2**

Foot/CQ2L

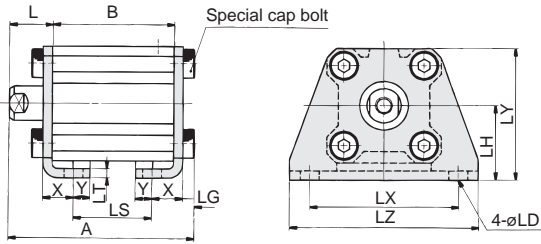

Rod end male thread

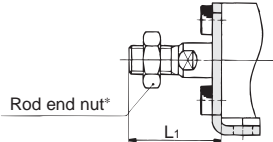

Front flange/CQ2F

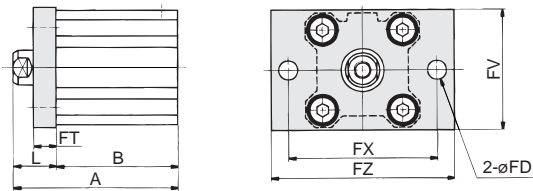

Rod end male thread

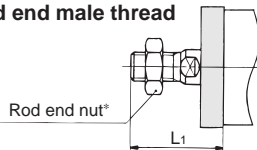

Rear flange/CQ2G

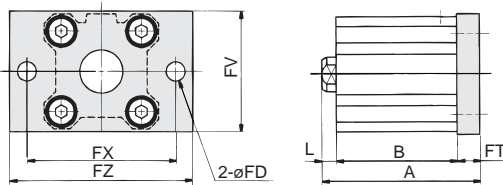

Rod end male thread

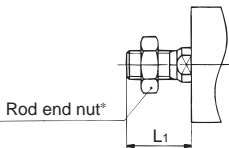

Double clevis/CQ2D

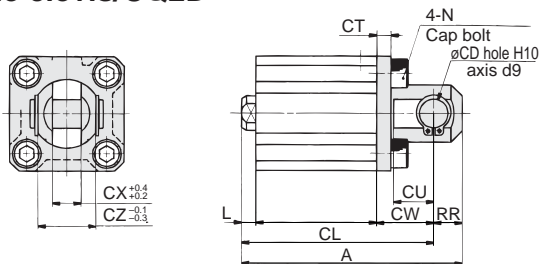

Rod end male thread

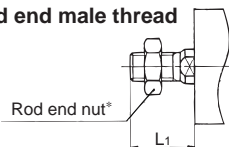

Foot

(mm)

Bore (mm)	A		B		L	L1	LD	LG	LH	LS		LT	LX	LY	LZ	X	Y
	5st	10st	5st	10st						5st	10st						
	12	40.3	45.3	22						27	13.5						
16	41.8	46.8	23.5	28.5	13.5	25.5	4.5	2.8	19	11.5	16.5	2	38	33.5	48	8	5
20	46.2	51.2	24.5	29.5	14.5	28.5	6.6	4	24	12.5	17.5	3.2	48	42	62	9.2	5.8
25	49.7	54.7	27.5	32.5	15	32.5	6.6	4	26	12.5	17.5	3.2	52	46	66	10.7	5.8

Front flange

(mm)

Bore (mm)	A		B		FD	FT	FV	FX	FZ	L	L1
	5st	10st	5st	10st							
	12	35.5	40.5	22							
16	37	42	23.5	28.5	4.5	5.5	30	45	55	13.5	25.5
20	39	44	24.5	29.5	6.6	8	39	48	60	14.5	28.5
25	42.5	47.5	27.5	32.5	6.6	8	42	52	64	15	32.5

Rear flange (mm)

(*Dimensions are same as rod side flange except A, L and L1.)

Bore (mm)	A		L	L1
	5st	10st		
	12	31		
16	32.5	37.5	3.5	15.5
20	37	42	4.5	18.5
25	40.5	45.5	5	22.5

Double clevis

(mm)

Bore (mm)	A		B		CD	CL		CT	CU	CW	CX	CZ	L	L1	N	RR
	5st	10st	5st	10st		5st	10st									
	12	45.5	50.5	22		27	5									
16	48	53	23.5	28.5	5	42	47	4	10	15	6.5	12	3.5	15.5	M4 X 0.7	6
20	56	61	24.5	29.5	8	47	52	5	12	18	8	16	4.5	18.5	M6 X 1.0	9
25	62.5	67.5	27.5	32.5	10	52.5	57.5	5	14	20	10	20	5	22.5	M6 X 1.0	10

* Refer to p.2.3-18 & 19 for rod end nut and option brackets.
** Clevis pin and snap ring are contained.

CUJ

CU

CQS

CQ2

RQ

MU

Series CDQ2

ø12 to ø25 Spring Return With Auto Switch

Both ends tapped: CDQ2A

Standard (Through-hole)/CDQ2B

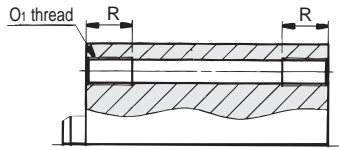

Both ends tapped (mm)

Bore (mm)	O1	R
12	M4 X 0.7	7
16	M4 X 0.7	7
20	M6 X 1.0	10
25	M6 X 1.0	10

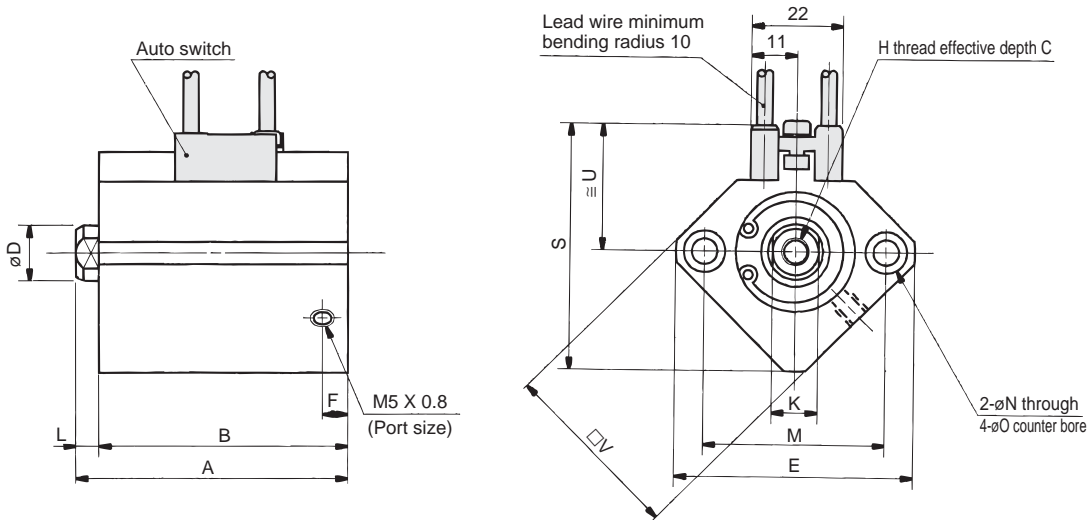

Rear boss mount

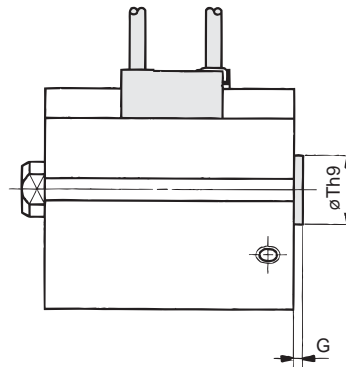

Rear boss mount (mm)

Bore (mm)	G	Th9
12	1.5	15 ⁰ _{-0.043}
16	1.5	20 ⁰ _{-0.052}
20	2	13 ⁰ _{-0.043}
25	2	15 ⁰ _{-0.043}

Rod end male thread

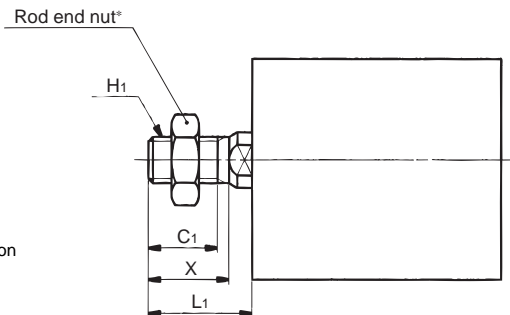

Rod end male thread (mm)

Bore (mm)	C1	X	H1	L1
12	9	10.5	M5 X 0.8	14
16	10	12	M6 X 1.0	15.5
20	12	14	M8 X 1.25	18.5
25	15	17.5	M10 X 1.25	22.5

Auto switch shown above is D-A73 and D-A80.
Refer to p.2.3-20 for auto switch mounting position and mounting height.

Standard

Bore (mm)	A		B		C	D	E	F	H	K	L	M	N	O	S	U	V
	5st	10st	5st	10st													
12	36.5	41.5	33	38	6	6	32	6.5	M3 X 0.5	5	3.5	22	3.5	6.5 Depth 3.5	35.5	19.5	25
16	39	44	35.5	40.5	8	8	38	5.5	M4 X 0.7	6	3.5	28	3.5	6.5 Depth 3.5	41.5	22.5	29
20	41	46	36.5	41.5	7	10	47	5.5	M5 X 0.8	8	4.5	36	5.5	9 Depth 7	48	24.5	36
25	42.5	47.5	37.5	42.5	12	12	52	5.5	M6 X 1.0	10	5	40	5.5	9 Depth 7	53.5	27.5	40

* Refer to p.2.3-18 & 19 for rod end nut and optional bracket

Compact Cylinder/Standard: Single Acting Spring Return/Extend **Series CQ2**

Foot/CDQ2L

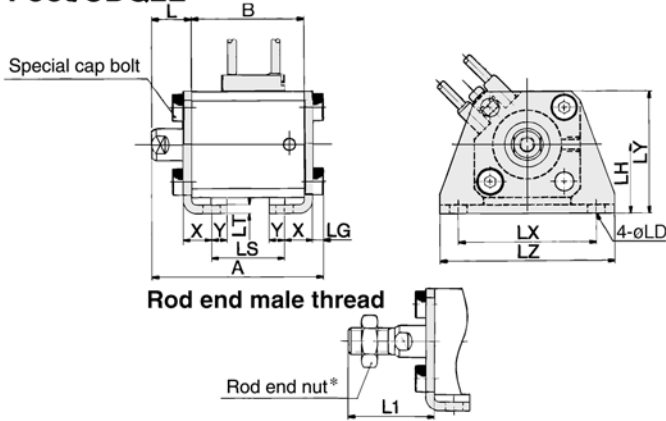

Foot

(mm)

Bore (mm)	A		B		L	L1	LD	LG	LH	LS		LT	LX	LY	LZ	X	Y
	5st	10st	5st	10st						5st	10st						
	12	51.3	56.3	33						38	13.5						
16	53.8	58.8	35.5	40.5	13.5	25.5	4.5	2.8	19	23.5	28.5	2	38	33.5	48	8	5
20	58.2	63.2	36.5	41.5	14.5	28.5	6.6	4	24	24.5	29.5	3.2	48	42	62	9.2	5.8
25	59.7	64.7	37.5	42.5	15	32.5	6.6	4	26	22.5	27.5	3.2	52	46	66	10.7	5.8

Front flange/CDQ2F

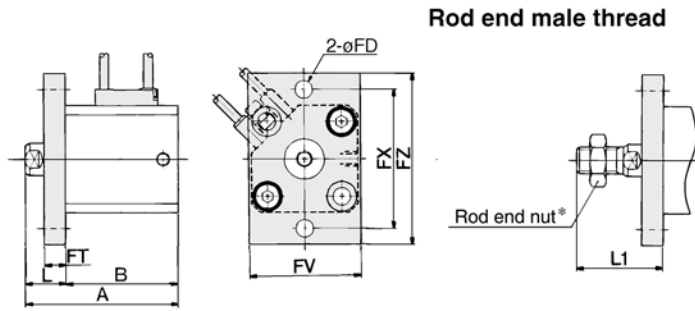

Front flange

(mm)

Bore (mm)	A		B		FD	FT	FV	FX	FZ	L	L1
	5st	10st	5st	10st							
12	46.5	51.5	33	38	4.5	5.5	25	45	55	13.5	24
16	49	54	35.5	40.5	4.5	5.5	30	45	55	13.5	25.5
20	51	56	36.5	41.5	6.6	8	39	48	60	14.5	28.5
25	52.5	57.5	37.5	42.5	6.6	8	42	52	64	15	32.5

Rear flange/CDQ2G

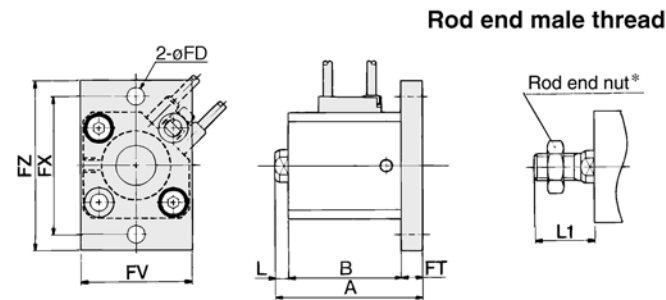

Rear flange

(mm)

Bore (mm)	A		L	L1
	5st	10st		
12	46.4	51.4	3.5	14
16	44.5	49.5	3.5	15.5
20	49	54	4.5	18.5
25	50.5	55.5	5	22.5

(* Dimensions except A, L and L1) are same as rod flange type.

Double clevis/CDQ2D

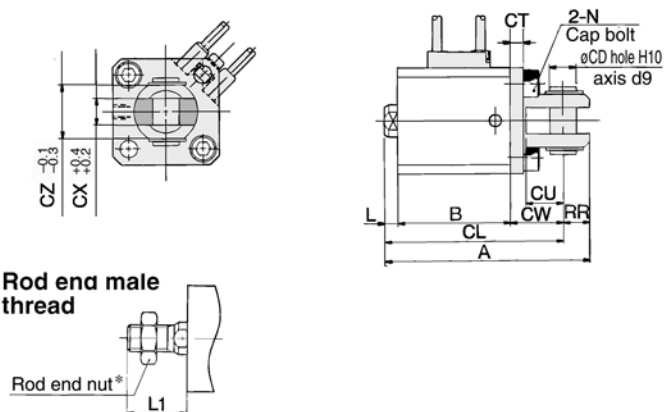

Double clevis

(mm)

Bore (mm)	A		B		CD	CL		CT	CU	CW	CX	CZ	L	L1	N	RR
	5st	10st	5st	10st		5st	10st									
	12	56.5	61.5	33		38	5									
16	60	65	35.5	40.5	5	54	59	4	10	15	6.5	12	3.5	15.5	M4 X 0.7	6
20	68	73	36.5	41.5	8	59	64	5	12	18	8	16	4.5	18.5	M6 X 1.0	9
25	72.5	77.5	37.5	42.5	10	62.5	67.5	5	14	20	10	20	5	22.5	M6 X 1.0	10

* Refer to p.2.3-18 & 19 for rod end nut and option bracket.
** Clevis pin and snap ring are contained.

CUJ

CU

CQS

CQ2

RQ

MU

Series CQ2/CDQ2



ø32 to ø50 Spring Return With Auto Switch

Refer to dimensions table since dimensions of A, B, F and P are different when auto switch is not mounted.

Standard (Through-hole)/CQ2B, CDQ2B

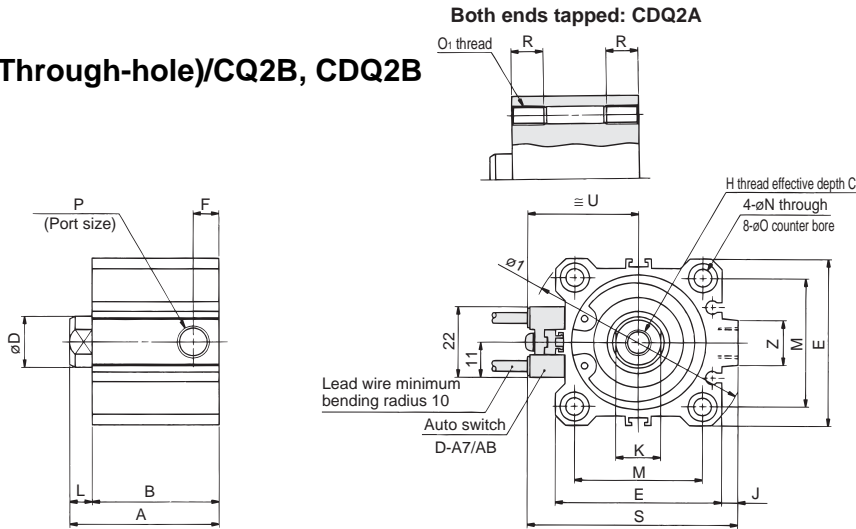

Both ends tapped mm

Bore (mm)	O1	R
32	M6 X 1.0	10
40	M6 X 1.0	10
50	M8 X 1.25	14

Rear boss mount

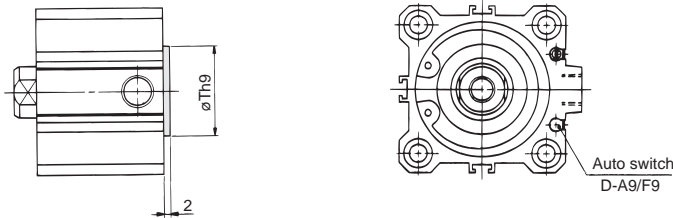

Rear boss mount(mm)

Bore (mm)	Th9
32	21 ⁰ _{-0.052}
40	28 ⁰ _{-0.052}
50	35 ⁰ _{-0.062}

Rod end male thread

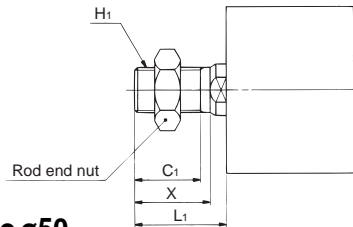

Rod end male thread (mm)

Bore (mm)	C1	X	H1	L1
32	20.5	23.5	M14 X 1.5	28.5
40	20.5	23.5	M14 X 1.5	28.5
50	26	28.5	M18 X 1.5	33.5



Auto switch shown above is D-A73 and D-A80. Refer to p.2.3-20 for auto switch mounting position and mounting height.

With built-in One-touch fitting/ø32 to ø50

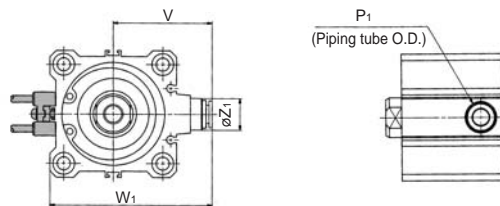

With built-in One-touch fitting (mm)

Bore (mm)	Z1	P1	V	W1
32	13	6	36.5	59
40	13	6	40.5	66.5
50	16	8	50	82

Standard

(mm)

Bore (mm)	Without auto switch										With auto switch									
	A			B			F			P			A			B			F	P
5st	10	20	5st	10	20	5st	10	20	5st	10	20	5st	10	20	5st	10	20			
32	35	40	—	28	33	—	5.5	7.5	—	M5 X 0.8	1/8	—	45	50	—	38	43	—	7.5	1/8
40	41.5	46.5	—	34.5	39.5	—	8	8	—	1/8	—	—	51.5	56.5	—	44.5	49.5	—	8	1/8
50	—	48.5	58.5	—	40.5	50.5	—	10.5	10.5	—	1/4	—	58.5	68.5	—	50.5	60.5	—	10.5	1/4

Bore (mm)	C	D	E	H	I	J	K	L	M	N	O	S	U	Z
32	13	16	45	M8 X 1.25	60	4.5	14	7	34	5.5	9 Depth 7	58.5	31.5	14
40	13	16	52	M8 X 1.25	69	5	14	7	40	5.5	9 Depth 7	66	35	14
50	15	20	64	M10 X 1.5	86	7	17	8	50	6.6	11 Depth 8	80	41	19



Refer to p.2.3-18 & 19 for rod end nut and option bracket.

Compact Cylinder/Standard: Single Acting Spring Return/Extend **Series CQ2**

Foot/CQ2L, CDQ2L

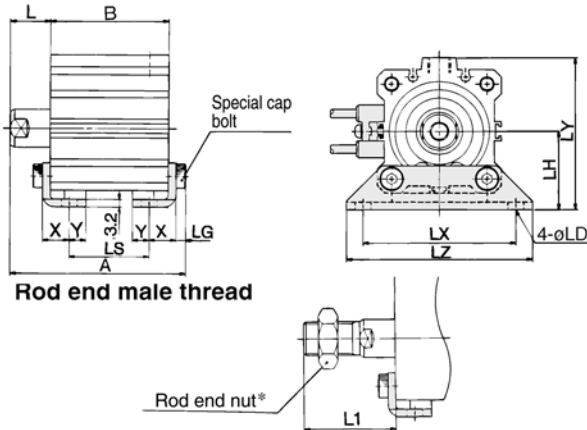

Foot

(mm)

Bore (mm)	Without auto switch									With auto switch								
	A			B			LS			A			B			LS		
	5st	10	20	5st	10	20	5st	10	20	5st	10	20	5st	10	20	5st	10	20
32	52.5	57.2	—	28	33	—	12	17	—	62.2	67.2	—	38	43	—	22	27	—
40	58.7	63.7	—	34.5	39.5	—	18.5	23.5	—	68.7	73.7	—	44.5	49.5	—	28.5	33.5	—
50	—	66.7	76.7	—	40.5	50.5	—	17.5	27.5	—	76.7	86.7	—	50.5	60.5	—	27.5	37.5

Bore (mm)	L	L1	LD	LG	LH	LX	LY	LZ	X	Y
32	17	38.5	6.6	4	30	57	57	71	11.2	5.8
40	17	38.5	6.6	4	33	64	64	78	11.2	7
50	18	43.5	9	5	39	79	78	95	14.7	8

Front flange/CQ2F, CDQ2F

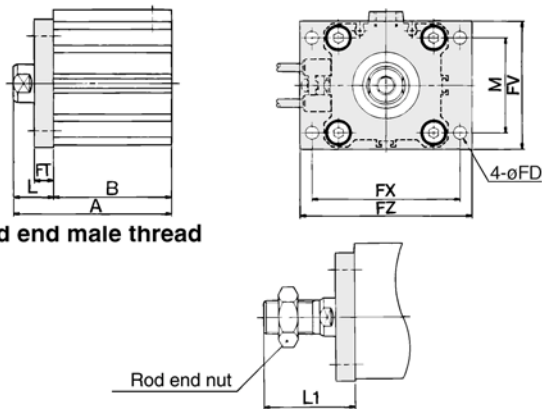

Front flange

(mm)

Bore (mm)	Without auto switch									With auto switch								
	A			B			A			B			A			B		
	5st	10	20	5st	10	20	5st	10	20	5st	10	10	5st	10	10			
32	45	50	—	28	33	—	55	60	—	38	43	—	—	—	—			
40	51.5	56.5	—	34.5	39.5	—	61.5	66.5	—	44.5	49.5	—	—	—	—			
50	—	58.5	68.5	—	40.5	50.5	—	68.5	78.5	—	50.5	60.5	—	—	—			

Bore (mm)	FD	FT	FV	FX	FZ	L	L1	M
32	5.5	8	48	56	65	17	38.5	34
40	5.5	8	54	62	72	17	38.5	40
50	6.6	9	67	76	89	18	43.5	50

Rear flange/CQ2G, CDQ2G

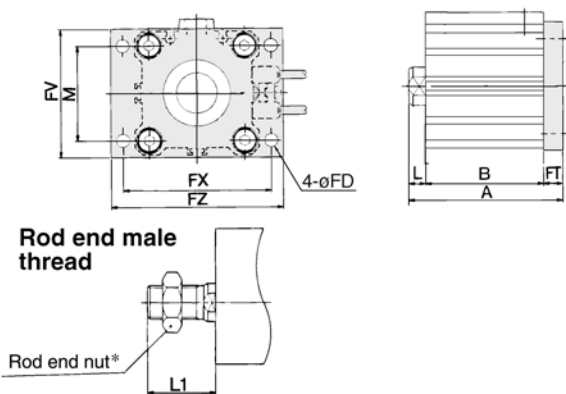

Rear flange

(mm)

Bore size (mm)	W/o auto switch			W/ auto switch			L	L1
	A		B		L	L1		
	5st	10	20	5st				
32	43	48	—	53	58	—	7	28.5
40	49.5	54.5	—	59.5	64.5	—	7	28.5
50	—	57.5	67.5	—	67.5	77.5	8	33.5

(* Dimensions except A, L and L1 are same as rear flange type.)

Double clevis/CQ2D, CDQ2D

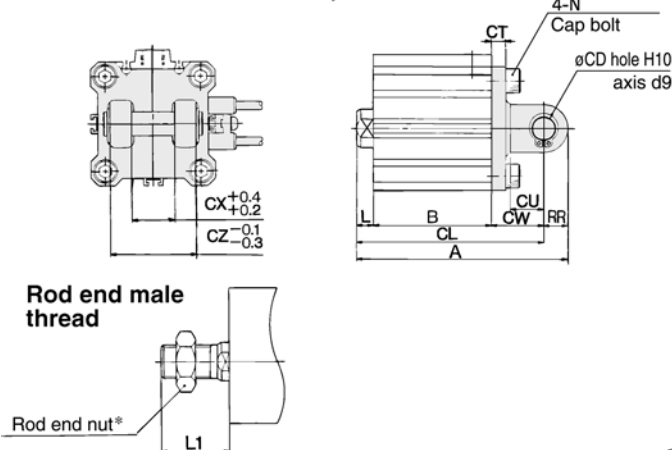

Double clevis

(mm)

Bore (mm)	Without auto switch									With auto switch								
	A			B			CL			A			B			CL		
	5st	10	20	5st	10	20	5st	10	20	5st	10	20	5st	10	20	5st	10	20
32	65	70	—	28	33	—	55	60	—	75	80	—	38	43	—	65	70	—
40	73.5	78.5	—	39.5	39.5	—	63.5	68.5	—	83.5	88.5	—	44.5	49.5	—	73.5	78.5	—
50	—	90.5	100.5	—	40.5	50.5	—	76.5	86.5	—	100.5	110.5	50.5	50.5	60.5	—	86.5	96.5

Bore (mm)	CD	CT	CU	CW	CX	CZ	L	L1	N	RR
32	10	5	14	20	18	36	7	28.5	M6 X 1.0	10
40	10	6	14	22	18	36	7	28.5	M6 X 1.0	10
50	14	7	20	28	22	44	8	33.5	M8 X 1.25	14



* Refer to p.2.3-18 & 19 for details of rod end nut and optional bracket.

** Clevis pin and snap ring are attached.

CUJ

CU

CQS

CQ2

RQ

MU

Series CQ2/CDQ2

ø12 to ø25 Spring Extend Without Auto Switch

Standard (Through-hole)/CQ2B

Both ends tapped: CQ2A

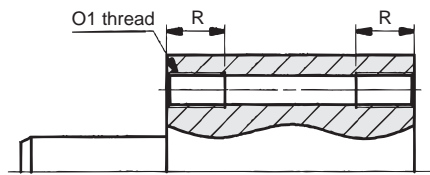

Both ends tapped (mm)

Bore (mm)	O1	R
12	M4 X 0.7	7
16	M4 X 0.7	7
20	M6 X 1.0	10
25	M6 X 1.0	10

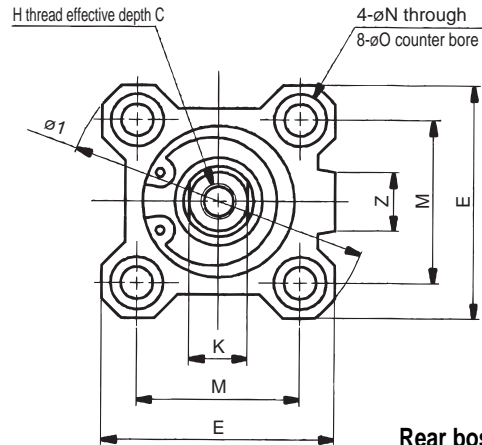
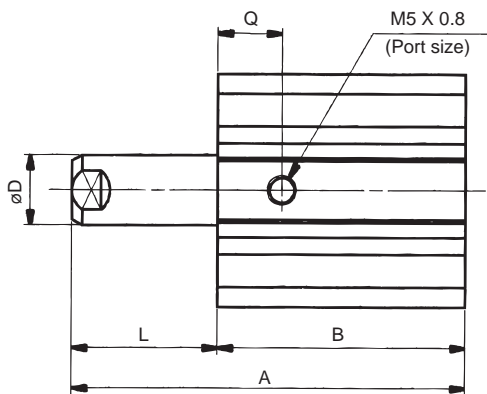

Rear boss mount

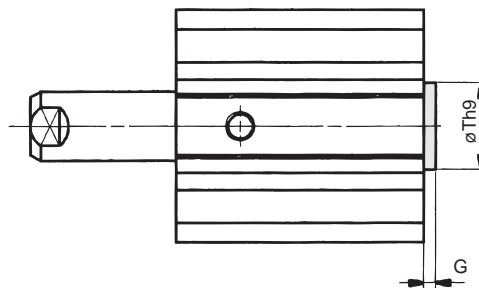

Rear boss mount (mm)

Bore (mm)	G	Th9
12	1.5	15 ⁰ _{-0.043}
16	1.5	20 ⁰ _{-0.052}
20	2	13 ⁰ _{-0.043}
25	2	15 ⁰ _{-0.043}

Note 1) Front boss mount is optional specification. (Specify "-XC36" at the end of model number.)

Rod end male thread

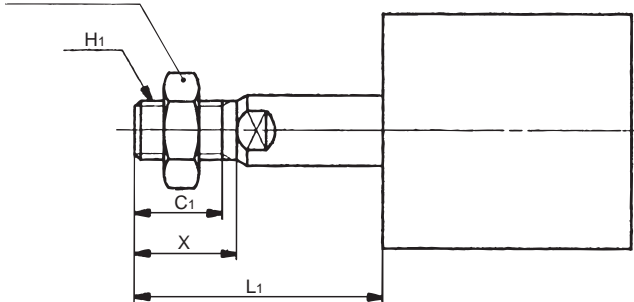

Rod end male thread (mm)

Bore (mm)	C1	X	H1	L1	
				5st	10st
12	9	10.5	M5 X 0.8	19	24
16	10	12	M6 X 1.0	20.5	25.5
20	12	14	M8 X 1.25	23.5	28.5
25	15	17.5	M10 X 1.25	27.5	32.5

Standard

(mm)

Bore (mm)	A		B		C	D	E	H	I	K	L		M	N	O	Q	Z
	5st	10st	5st	10st							5st	10st					
12	30.5	40.5	22	27	6	6	25	M3 X 0.5	32	5	8.5	13.5	15.5	3.5	6.5 Depth 3.5	7.5	-
16	32	42	23.5	28.5	8	8	29	M4 X 0.7	38	6	8.5	13.5	20	3.5	6.5 Depth 3.5	8	10
20	34	44	24.5	29.5	7	10	36	M5 X 0.8	47	8	9.5	14.5	25.5	5.5	9 Depth 7	9	10
25	37.5	47.5	27.5	32.5	12	12	40	M6 X 1.0	52	10	10	15	28	5.5	9 Depth 7	11	10

* Refer to p.2.3-18 & 19 for details of rod end nut and optional bracket.

Compact Cylinder/Standard: Single Acting Spring Return/Extend **Series CQ2**

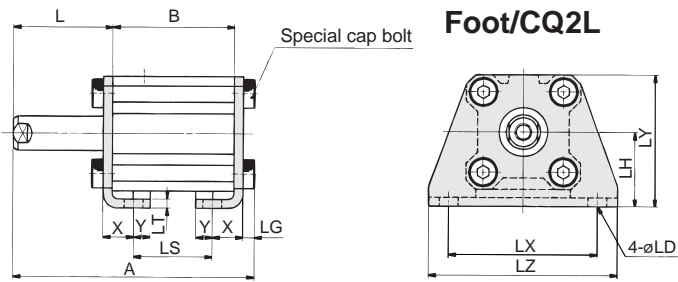

Foot (mm)

Bore (mm)	A		B		L		L1		LD	LG	LH	LS		LT	LX	LY	LZ	X	Y
	5st	10st	5st	10st	5st	10st	5st	10st				5st	10st						
12	45.3	55.3	22	27	18.5	23.5	29	34	4.5	2.8	17	10	15	2	34	29.5	44	8	4.5
16	46.8	56.8	23.5	28.5	18.5	23.5	30.5	35.5	4.5	2.8	19	11.5	16.5	2	38	33.5	48	8	5
20	51.2	61.2	24.5	29.5	19.5	24.5	33.5	38.5	6.6	4	24	12.5	17.5	3.2	48	42	62	9.2	5.8
25	54.7	64.7	27.5	32.5	20	25	37.5	42.5	6.6	4	26	12.5	17.5	3.2	52	46	66	10.7	5.8

Rod end nut

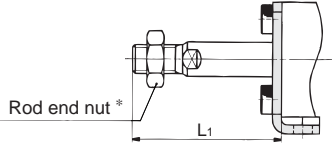

Front flange/CQ2F

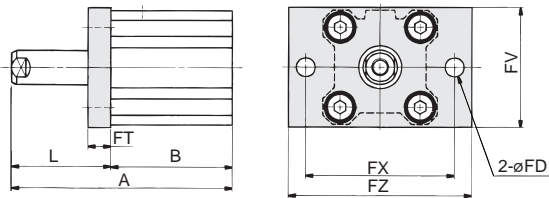

Front flange (mm)

Bore (mm)	A		B		FD	FT	FV	FX	FZ	L		L1	
	5st	10st	5st	10st						5st	10st	5st	10st
12	40.5	50.5	22	27	4.5	5.5	25	45	55	18.5	23.5	29	34
16	42	52	23.5	28.5	4.5	5.5	30	45	55	18.5	23.5	30.5	35.5
20	44	54	24.5	29.5	6.6	8	39	48	60	19.5	24.5	33.5	38.5
25	47.5	57.5	27.5	32.5	6.6	8	42	52	64	20	25	37.5	42.5

Rod end nut

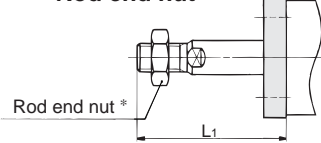

Rear flange/CQ2G

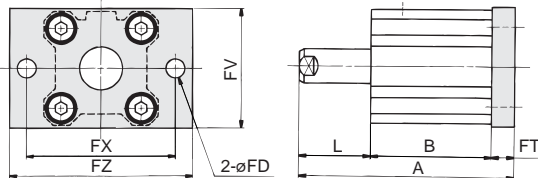

Rear flange (mm)

Bore (mm)	A		L		L1	
	5st	10st	5st	10st	5st	10st
12	36	46	8.5	13.5	19	24
16	37.5	47.5	8.5	13.5	20.5	25.5
20	42	52	9.5	14.5	23.5	28.5
25	45.5	55.5	10	15	27.5	32.5

(* Dimensions except A, L and L1) are same as front flange.

Rod end nut

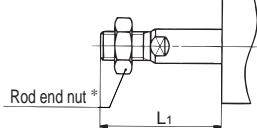

Double clevis/CQ2D

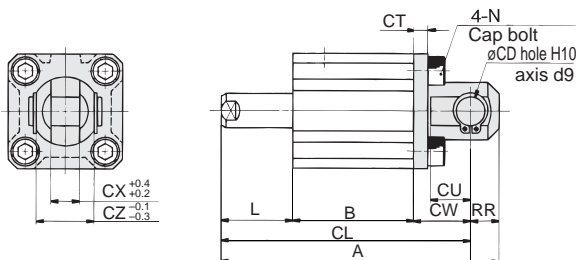

Double clevis (mm)

Bore (mm)	A		B		CD	CL		CT	CU	CW	CX	CZ	L		L1		N	RR
	5st	10st	5st	10st		5st	10st						5st	10st				
12	50.5	60.5	22	27	5	44.5	54.5	4	7	14	5	10	8.5	13.5	19	24	M4 X 0.7	6
16	53	63	23.5	28.5	5	47	57	4	10	15	6.5	12	8.5	13.5	20.5	25.5	M4 X 0.7	6
20	61	71	24.5	29.5	8	52	62	5	12	18	8	16	9.5	14.5	23.5	28.5	M6 X 1.0	9
25	67.5	77.5	27.5	32.5	10	57.5	67.5	5	14	20	10	20	10	15	27.5	32.5	M6 X 1.0	10



* Refer to page p.2.3-18 & 19 for details of rod end nut and optional brackets.
** Clevis pin and snap ring are attached.

Rod end nut

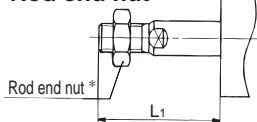

CUJ

CU

CQS

CQ2

RQ

MU

Series CDQ2

ø12 to ø25 Spring Extend With Auto Switch

Both ends tapped: CDQ2A

Standard(Through-hole)/CDQ2B

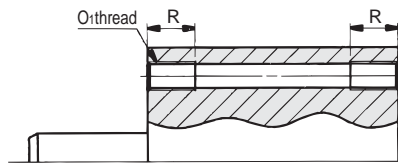

Both ends tapped (mm)

Bore (mm)	O1	R
12	M4 X 0.7	7
16	M4 X 0.7	7
20	M6 X 1.0	10
25	M6 X 1.0	10

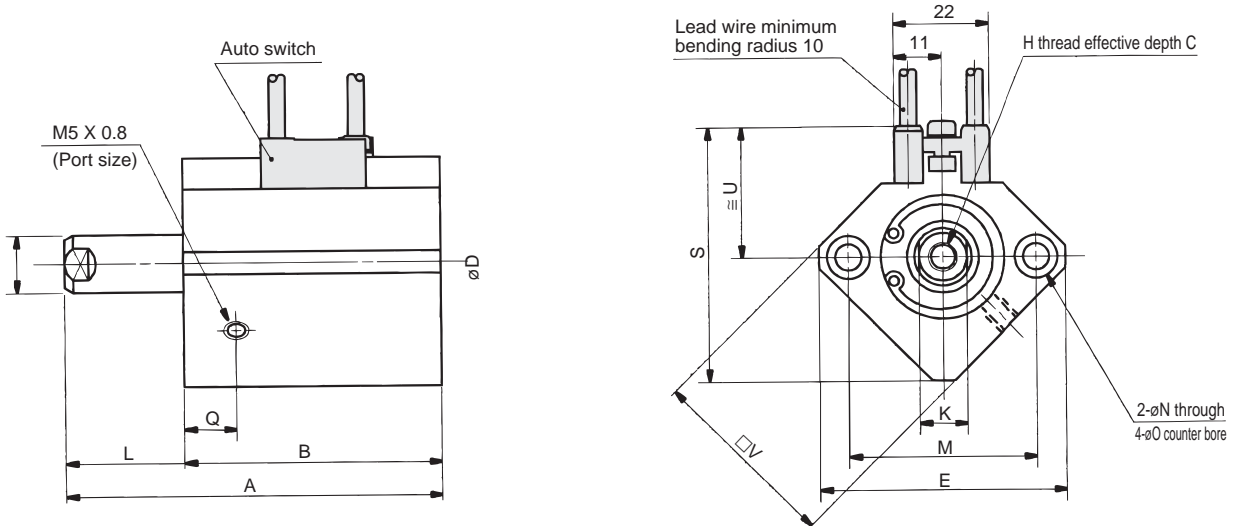

Rear boss mount

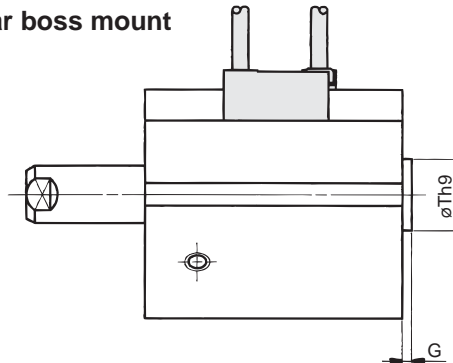

Rear boss mount (mm)

Bore (mm)	G	Th9
12	1.5	15 ⁰ _{-0.043}
16	1.5	20 ⁰ _{-0.052}
20	2	13 ⁰ _{-0.043}
25	2	15 ⁰ _{-0.043}

Note 1) Rod side end boss type is optional specification. (Specify "-XC36" at the end of model number.)

Rod end male thread

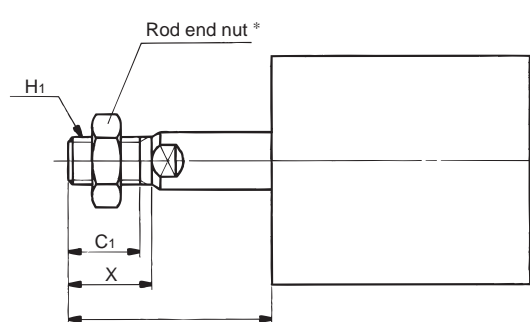

Rod end male thread (mm)

Bore (mm)	C1	X	H1	L1	
				5st	10st
12	9	10.5	M5 X 0.8	19	24
16	10	12	M6 X 1.0	20.5	25.5
20	12	14	M8 X 1.25	23.5	28.5
25	15	17.5	M10 X 1.25	27.5	32.5



Above auto switch: D-A73 and A80. Refer to p.2.3-20 for auto switch mounting position and mounting height.

Standard type

Bore (mm)	A		B		C	D	E	H	K	L		M	N	O	Q	S	U	V
	5st	10st	5st	10st						5st	10st							
12	45.9	55.9	37.4	42.4	6	6	32	M3 X 0.5	5	8.5	13.5	22	3.5	6.5 Depth 3.5	11	35.5	19.5	25
16	44	54	35.5	40.5	8	8	38	M4 X 0.7	6	8.5	13.5	28	3.5	6.5 Depth 3.5	10	41.5	22.5	29
20	46	56	36.5	41.5	7	10	47	M5 X 0.8	8	9.5	14.5	36	5.5	9 Depth 7	10.5	48	24.5	36
25	47.5	57.5	37.5	42.5	12	12	52	M6 X 1.0	10	10	15	40	5.5	9 Depth 7	11	53.5	27.5	40

* Refer to p.2.3-18 & 19 for details of rod end nut and optional brackets.

Compact Cylinder/Standard: Single Acting Spring Return/Extend **Series CDQ2**

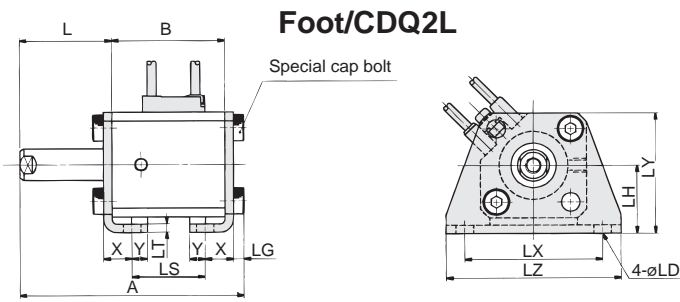

Foot

Bore (mm)	(mm)																		
	A		B		L		L ₁		LD	LG	LH	LS		LT	LX	LY	LZ	X	Y
	5st	10st	5st	10st	5st	10st	5st	10st				5st	10st						
12	60.7	70.7	37.4	42.4	18.5	23.5	29	34	4.5	2.8	17	21	26	2	34	29.5	44	8	4.5
16	58.8	68.8	35.5	40.5	18.5	23.5	30.5	35.5	4.5	2.8	19	23.5	28.5	2	38	33.5	48	8	5
20	63.2	73.2	36.5	41.5	19.5	24.5	33.5	38.5	6.6	4	24	24.5	29.5	3.2	48	42	62	9.2	5.8
25	64.7	74.7	37.5	42.5	20	25	37.5	42.5	6.6	4	26	22.5	27.5	3.2	52	46	66	10.7	5.8

Rod end male thread

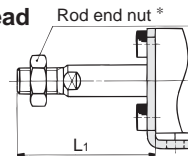

Front flange/CDQ2F

Front flange

Bore (mm)	(mm)												
	A		B		FD	FT	FV	FX	FZ	L		L ₁	
	5st	10st	5st	10st						5st	10st		
12	55.9	65.9	37.4	42.4	4.5	5.5	25	45	55	18.5	23.5	29	34
16	54	64	35.5	40.5	4.5	5.5	30	45	55	18.5	23.5	30.5	35.5
20	56	66	36.5	41.5	6.6	8	39	48	60	19.5	24.5	33.5	38.5
25	57.5	67.5	37.5	42.5	6.6	8	42	52	64	20	25	37.5	42.5

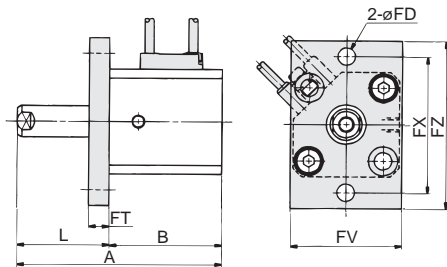

Rod end male thread

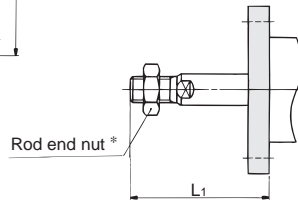

Rear flange/CDQ2G

Rear flange

Bore (mm)	(mm)					
	A		L		L ₁	
	5st	10st	5st	10st	5st	10st
12	51.4	61.4	8.5	13.5	19	24
16	49.5	59.5	8.5	13.5	20.5	25.5
20	54	64	9.5	14.5	23.5	28.5
25	55.5	65.5	10	15	27.5	32.5

(*Dimensions except A, L and L₁ are same as rear flange type.)

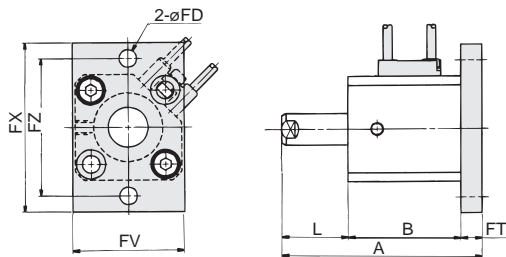

Rod end male thread

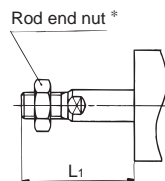

Double clevis/CDQ2D

Double clevis

Bore (mm)	(mm)													
	A		B		CD	CL		CT	CU	CW	CX	CZ	L	
	5st	10st	5st	10st		5st	10st						5st	10st
12	65.9	75.9	37.4	42.4	5	59.9	69.9	4	7	14	5	10	8.5	13.5
16	65	75	35.5	40.5	5	59	69	4	10	15	6.5	12	8.5	13.5
20	73	83	36.5	41.5	8	64	74	5	12	18	8	16	9.5	14.5
25	77.5	87.5	37.5	42.5	10	67.5	77.5	5	14	20	10	20	10	15

Bore (mm)	(mm)			
	L ₁		N	RR
	5st	10st		
12	19	24	M4 X 0.7	6
16	20.5	25.5	M4 X 0.7	6
20	23.5	28.5	M6 X 1.0	9
25	27.5	32.5	M6 X 1.0	10

* Refer to p.2.3-18 & 19 for details of rod end nut and optional brackets.

** Clevis pin and snap ring are attached.

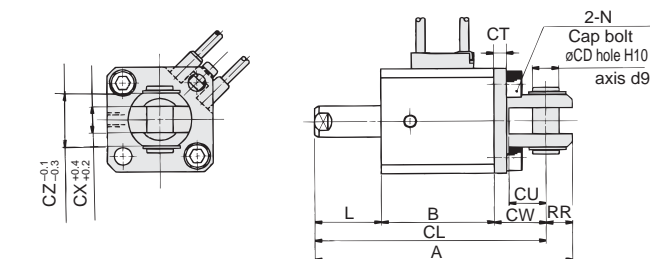

Rod end male thread

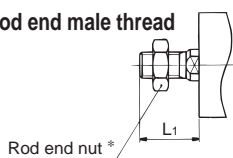

CUJ

CU

CQS

CDQ2

RQ

MU

Series CQ2/CDQ2

ø32 to ø50 Spring Extend With Auto Switch

Refer to dimensions table since A, B, P and Q varies in case of without auto switch.

Both ends tapped: CQ2A/CDQ2A

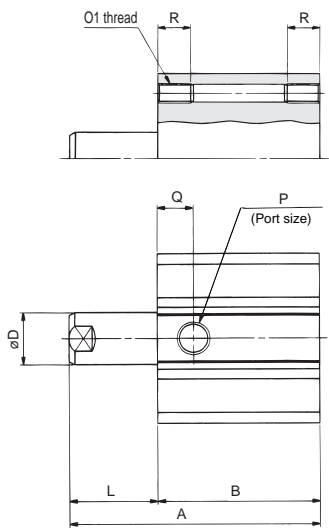

Standard (Through-hole)/CQ2B, CDQ2B

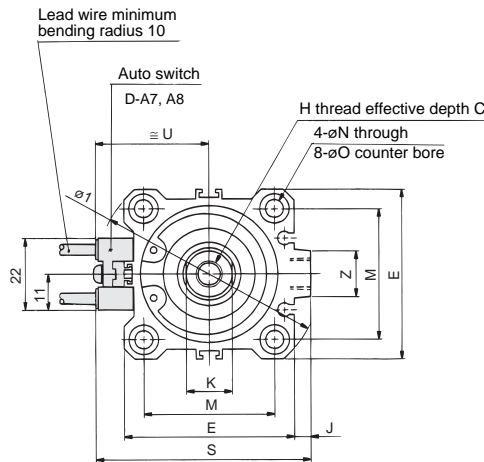

Rear boss mount

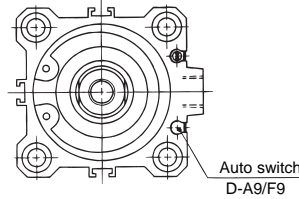
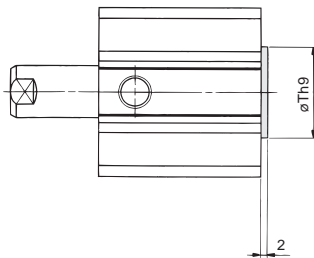

Rod end male thread

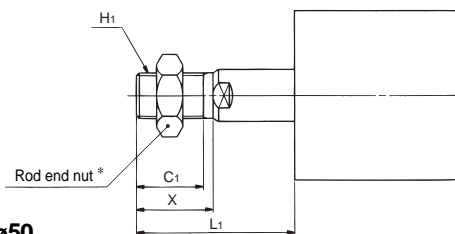

Built-in One-touch fitting/ø32 to ø50



Above auto switch: D-A73/A80
Refer to p.2.3-20 for auto switch setting position and mounting height.

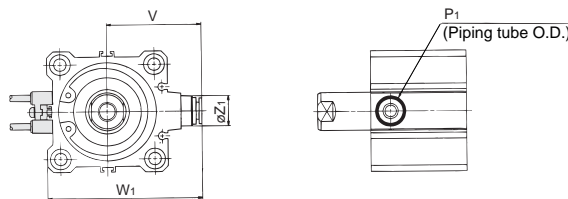

Both ends tapped (mm)

Bore (mm)	O1	R
32	M6 X 1.0	10
40	M6 X 1.0	10
50	M8 X 1.25	14

Rear boss mount (mm)

Bore (mm)	Th9
32	21 ⁰ _{-0.052}
40	28 ⁰ _{-0.052}
50	35 ⁰ _{-0.062}

Note 1) Front boss mount is optional specification. (Specify "-XC36" at the end of model number.)

Rod end male thread (mm)

Bore (mm)	C ₁	X	H ₁	L ₁		
				5st	10st	20st
32	20.5	23.5	M14 X 1.5	33.5	38.5	—
40	20.5	23.5	M14 X 1.5	33.5	38.5	—
50	26	28.5	M18 X 1.5	—	43.5	53.5

Built-in One-touch fitting (mm)

Bore (mm)	Z ₁	P ₁	V	W ₁
32	13	6	36.5	59
40	13	6	40.5	66.5
50	16	8	50	82

Standard

(mm)

Bore (mm)	Without auto switch												With auto switch							
	A			B			P			Q			A			B			P	Q
	5st	10	20	5st	10	20	5st	10	20	5st	10	20	5st	10	20	5st	10	20		
32	40	50	—	28	33	—	M6 X 0.8	1/8	—	11.5	10.5	—	50	60	—	38	43	—	1/8	10.5
40	46.5	56.5	—	34.5	39.5	—	—	1/8	—	11	11	—	56.5	66.5	—	44.5	49.5	—	1/8	11
50	—	68.5	78.5	—	40.5	50.5	—	—	1/4	—	10.5	10.5	—	68.5	88.5	—	50.5	60.5	1/4	10.5

Bore (mm)	C	D	E	H	I	J	K	L			M	N	O	S	U	Z
								5st	10	20						
32	13	16	45	M8 X 1.25	60	4.5	14	12	17	—	34	5.5	9 Depth 7	58.5	31.5	14
40	13	16	52	M8 X 1.25	69	5	14	12	17	—	40	5.5	9 Depth 7	66	35	14
50	15	20	64	M10 X 1.5	86	7	17	—	18	28	50	6.6	11 Depth 8	80	41	19



* Refer to p.2.3-18 & 19 for details of rod end nut and optional brackets.

Compact Cylinder/Standard: Single Acting Spring Return/Extend **Series CQ2**

Foot/CQ2L, CDQ2L

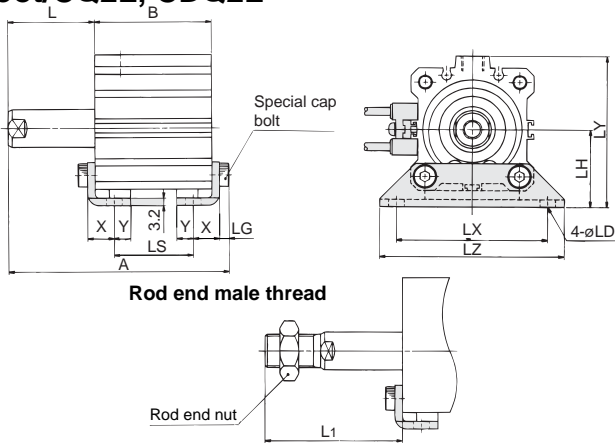

Foot

Bore (mm)	Without auto switch									With auto switch								
	A			B			LS			A			B			LS		
	5st	10	20	5st	10	20	5st	10	20	5st	10	20	5st	10	20	5st	10	20
32	57.2	67.2	—	28	33	—	12	17	—	67.2	77.2	—	38	43	—	22	27	—
40	63.7	73.7	—	34.5	39.5	—	18.5	23.5	—	73.7	83.7	—	44.5	49.5	—	28.5	33.5	—
50	—	76.7	96.7	—	40.5	50.5	—	17.5	27.5	—	86.7	106.7	—	50.5	60.5	—	27.5	37.5

Bore (mm)	L			L1			LD	LG	LH	LX	LY	LZ	X	Y
	5st	10	20	5st	10	20								
	32	22	27	—	43.5	48.5								
40	22	27	—	43.5	48.5	—	6.6	4	33	64	64	78	11.2	7
50	—	28	38	—	53.5	63.5	9	5	39	79	78	95	14.7	8

Front flange/CQ2F, CDQ2F

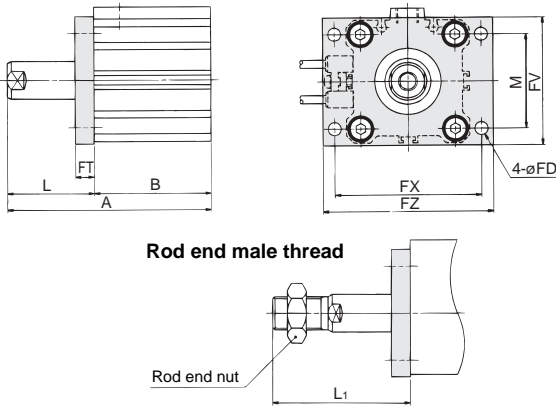

Front flange

Bore (mm)	Without auto switch						With auto switch						FD	FT	FV	FX	FZ
	A			B			A			B							
	5st	10	20	5st	10	20	5st	10	20	5st	10	20					
32	50	60	—	28	33	—	60	70	—	38	43	—	5.5	8	45	56	65
40	56.5	66.5	—	34.5	39.5	—	66.5	76.5	—	44.5	49.5	—	5.5	8	54	62	72
50	—	68.5	88.5	—	40.5	50.5	—	78.5	98.5	—	50.5	60.5	6.6	9	67	76	89

Bore (mm)	L			L1			M
	5st	10	20	5st	10	20	
	32	22	27	—	43.5	48.5	
40	22	27	—	43.5	48.5	—	40
50	—	28	38	—	53.5	63.5	50

Rear flange/CQ2G, CDQ2G

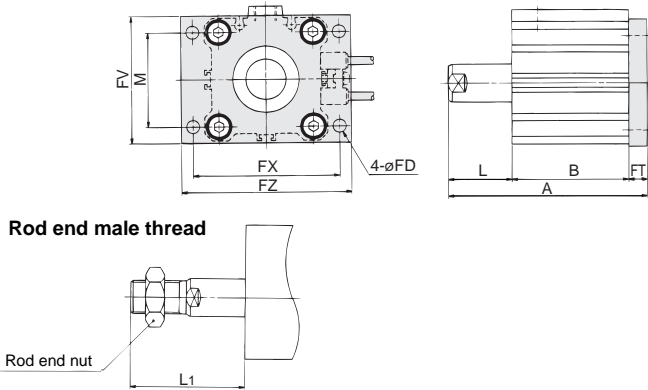

Rear flange

Bore (mm)	W/o auto switch			With auto switch			L			L1		
	A			B			L			L1		
	5st	10	20	5st	10	20	5st	10	20	5st	10	20
32	48	58	—	58	68	—	12	17	—	33.5	38.5	—
40	45.5	64.5	—	64.5	74.5	—	12	17	—	33.5	38.5	—
50	—	67.5	87.5	—	77.5	97.5	—	18	28	—	43.5	53.5

(* Dimensions except A, L and L1 are same as front flange.)

Double clevis/CQ2D, CDQ2D

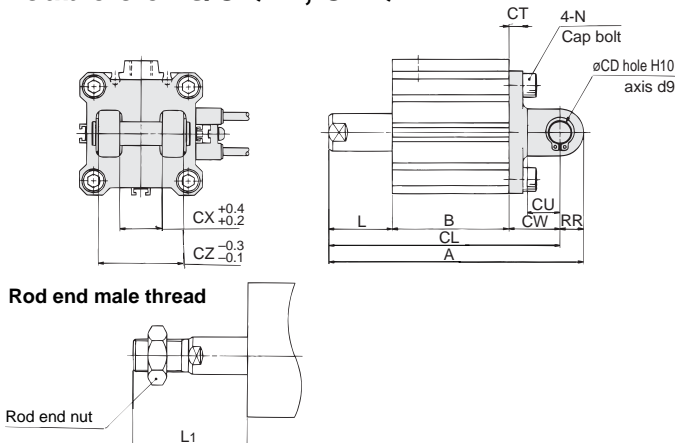

Double clevis

Bore (mm)	Without auto switch									With auto switch								
	A			B			CL			A			B			CL		
	5st	10	20	5st	10	20	5st	10	20	5st	10	20	5st	10	20	5st	10	20
32	70	80	—	28	33	—	60	70	—	80	90	—	38	43	—	70	80	—
40	78.5	88.5	—	34.5	39.5	—	68.5	78.5	—	88.5	98.5	—	44.5	49.5	—	78.5	88.5	—
50	—	100.5	120.5	—	40.5	50.5	—	86.5	106.5	—	110.5	130.5	—	50.5	60.5	—	96.5	116.5

Bore (mm)	CD	CT	CU	CW	CX	CZ	L		
							5st	10	20
							32	10	5
40	10	6	14	22	18	36	12	17	—
50	14	7	20	28	22	44	—	18	28

* Refer to p.2.3-18 & 19 for details of rod end nut and optional brackets.
** Clevis pin and snap ring are attached.

CUJ

CU

CQS

CQ2

RQ

MU

Compact Cylinder Non-rotating Rod: Double Acting Single Rod

Series CQ2K

ø12, ø16, ø20, ø25, ø32, ø40, ø50, ø63

How to Order

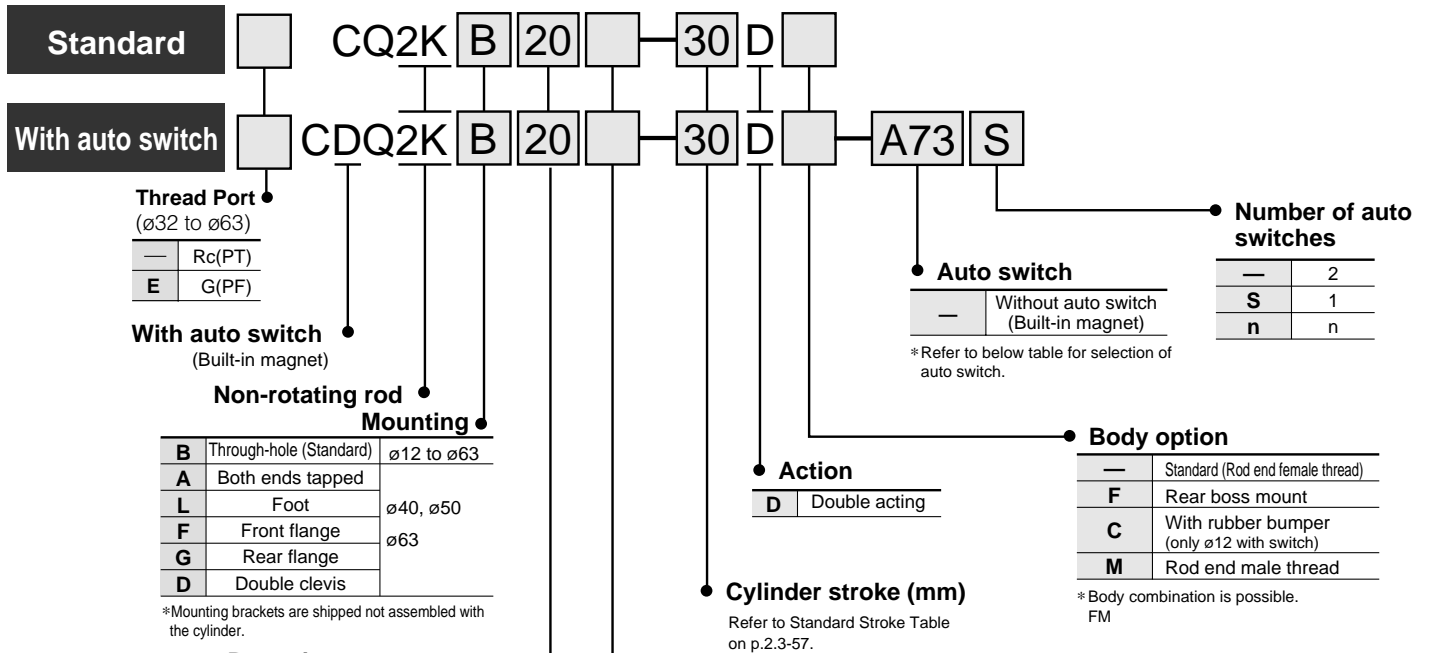

Bore size

12 ⁽¹⁾	12mm	32	32mm
16	16mm	40	40mm
20	20mm	50	50mm
25	25mm	63	63mm



Note 1) When ø12 with switch is required, the body option should be with rubber bumper (C).
Ex.) CDQ2KB12-30DC

Piping

—	Screw-in piping
F	With built-in One-touch fitting ⁽²⁾



Note 2) Bore size with built-in One-touch fitting is from ø32 to 63.

Mounting Bracket Part Number

Bore (mm)	Foot ⁽³⁾	Flange	Double clevis ⁽⁵⁾
40	CQ-L040	CQ-F040	CQ-D040
50	CQ-L050	CQ-F050	CQ-D050
63	CQ-L063	CQ-F063	CQ-D063



Note 3) When ordering foot brackets, 2pcs. should be ordered for each cylinder.

Note 4) The attached parts for each brackets are as follows.

Foot, Flange: Body mounting bolt
Double clevis: Clevis pin, C shape snap ring for axis, Body mounting bolt

Note 5) A clevis pin and snap ring are packed with the double clevis.

Applicable Auto Switches/Refer to p.5.3-2 for further information on auto switch.

Style	Special function	Electrical entry	Indicator	Wiring (Output)	Load voltage		Rail mounting		Direct mounting		Lead wire ^(m)				Applicable load			
					DC	AC	ø12 to ø63		ø32 to ø63		0.5 (-)	3 (L)	5 (Z)	None (N)				
							Perp.	In-line	Perp.	In-line								
Reed switch	—	Grommet	Yes	3 wire (Equiv. NPN)	—	5V	—	—	A76H	A96V	A96	●	●	—	—	IC		
						—	200V	A72	A72H	—	—	●	●	—	—	—		
						24V	12V	100V	A73	A73H	—	—	●	●	—	—	—	
							—	—	—	—	A93V	A93	●	●	—	—	—	
							5V, 12V	≤100V	A80	A80H	A90V	A90	●	●	—	—	IC	
							12V	—	A73C	—	—	—	●	●	●	●	—	
						5V, 12V	≤24V	A80C	—	—	—	—	●	●	●	●	IC	
						—	—	—	—	—	—	—	●	●	—	—	—	
						—	—	—	—	—	—	—	—	—	—	—	—	—
						Solid state switch	—	Grommet	Yes	3 wire (NPN)	—	5V, 12V	—	—	F7NV	F79	—	—
12V	—	—	F9NV	F9N	●							●	—	—	—			
5V, 12V	—	—	F7PV	F7P	—							—	●	●	○	—	IC	
—	—	—	—	F9PV	F9P							●	●	—	—	—		
12V	—	—	F7BV	J79	—							—	●	●	○	—	—	
	—	—	—	—	F9BV							F9B	●	●	—	—	—	
—	—	—	—	—	—							—	—	—	—	—	—	—
24V	5V, 12V	—	—	F7NVV	F79V							—	—	●	●	○	—	IC
	12V	—	—	—	F9NVV							F9NV	●	●	○	—	—	
	5V, 12V	—	—	—	F7PW							—	—	●	●	○	—	IC
	—	—	—	—	—	F9PWV	F9PW	●	●	○	—	—						
12V	—	—	—	F7BWW	J79W	F9BWW	F9BW	●	●	○	—	—						
	—	—	—	—	F7BA	—	F9BA	—	●	○	—	—						
	—	—	—	—	F7NT	—	—	—	●	○	—	IC						
	—	—	—	—	F79F	—	—	—	●	●	○	—	—					
—	—	—	—	—	—	—	—	—	—	—	—	—	—					
—	—	—	—	—	—	—	—	—	—	—	—	—	—					

* Lead wire length 0.5m..... — (Example) A80C 5m..... Z (Example) A80CZ
3m..... L (Example) A80CL None..... N (Example) A80CN

* Solid state switches marked with a "○" are manufactured upon receipt of order.

Compact Cylinder/Non-rotating Rod: Double Acting Single Rod *Series CQ2K*



Symbol

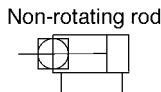

Made to Order

Refer to p.5.4-1 for common made to order common specifications and p.5.4-79 for individual specifications.

⚠ Precautions

Be sure to read before handling.
Refer to p.0-39 to 0-46 for Safety Instructions and common precautions.

⚠ Caution

Snap Ring Installation Removal

- For installation and removal, use an appropriate pair of pliers (tool for installing a C snap ring).
- Exercise caution even when using an appropriate pair of pliers (tool for installing a C snap ring), because of the possibility of the snap ring becoming detached from the tip of the pliers (tool for installing a C snap ring) and flying away, which could injure humans or damage the peripheral equipment. After installing the snap ring, make sure that it is placed securely in the ring groove before supplying air.

Mounting

- When removing a load, be sure to secure the flats of the piston rod on the load side.
- If this is done without securing the piston rod on the load side, be aware that the coupled (screwed-in) portion of the piston rod could become loosened.

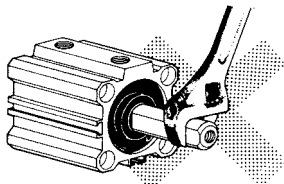

- Using a non-rotating rod cylinder
 - Avoid using the air cylinder in such a way that rotational torque would be applied to the piston rod. If rotational torque is applied, the non-rotating guide will deform, causing a loss of non-rotating accuracy. Use the chart below as a guide for the allowable rotational torque ranges.

Allowable torque kgf·cm or less	12	16	20	25	32	40	50	63
	0.4	1.5	2.0	2.5	4.5	4.5	4.5	4.5

- Operate the cylinder in such a way that the load to the piston rod is always applied in the axial direction.

Bore size (mm)		12	16	20	25	32	40	50	63	
Pneumatic	Mounting	Through-hole (Standard)	●	●	●	●	●	●	●	
		Both ends tapped	—	—	—	—	—	●	●	●
	Built-in magnet		●	●	●	●	●	●	●	
	Piping	Screw-in style	M5 X 0.8	M5 X 0.8	M5 X 0.8	M5 X 0.8	M5 X 0.8 ⁽¹⁾ 1/8	1/8	1/4	1/4
		With built-in One-touch fitting	—	—	—	—	ø6/4 ⁽²⁾	ø6/4	ø8/6	ø8/6
	Rod end male thread		●	●	●	●	●	●	●	●
Rear boss mount		●	●	●	●	●	●	●	●	

Note 1) When requiring style without auto switch, only 5 stroke uses M5 X 0.8.

Note 2) When requiring style with built-in fitting, dimensions of ø32 and 5stroke are same as 10stroke.

Standard Specifications

Style	Pneumatic (Non-lube)
Fluid	Air
Proof pressure	1.5MPa
Max. operating pressure	1.0MPa
Ambient and fluid temperature	Without auto switch: -10°C to 70°C (No freezing)
	With auto switch: -10°C to 60°C (No freezing)
Rubber bumper	None
Rod end thread	Female thread
Rod end tolerance	JIS class 2
Stroke length tolerance	+1.0 0
Mounting	Through-hole
Piston speed	50 to 500mm/s

Allowable Kinetic Energy

Bore size (mm)	12	16	20	25	32	40	50	63	80	100	Unit: J
Allowable kinetic energy	0.022	0.038	0.055	0.09	0.15	0.26	0.46	0.77	1.36	2.27	

Minimum Operating Pressure

Bore size (mm)	12	16	20	25	32	40	50	63	Unit: MPa
Min. operating press	0.07	0.07	0.05	0.05	0.05	0.05	0.05	0.05	

Non-rotating Accuracy

Bore size (mm)	12	16	20	25	32	40	50	63
Non-rotating accuracy	±2°	±1°			±0.8°			

Standard Stroke

Bore size	Standard stroke	Unit: mm
12, 16	5, 10, 15, 20, 25, 30	
20, 25	5, 10, 15, 20, 25, 30, 35, 40, 45, 50	
32, 40	5, 10, 15, 20, 25, 30, 35, 40, 45, 50, 75, 100	
50, 63	10, 15, 20, 25, 30, 35, 40, 45, 50, 75, 100	



Refer to p.2.3-3 for intermediate strokes.

Theoretical Force

Bore size (mm)	Operating direction	Operating pressure (MPa)			Bore size (mm)	Operating direction	Operating pressure (MPa)		
		0.3	0.5	0.7			0.3	0.5	0.7
12	IN	25	42	59	32	IN	181	302	422
	OUT	34	57	79		OUT	241	402	563
16	IN	45	75	106	40	IN	317	528	739
	OUT	60	101	141		OUT	377	628	880
20	IN	71	118	165	50	IN	495	825	1150
	OUT	94	157	220		OUT	589	982	1370
25	IN	113	189	264	63	IN	841	1400	1960
	OUT	147	245	344		OUT	935	1560	2180

Series CQ2K

Weight

Unit: g

Bore size (mm)	Cylinder stroke (mm)											
	5	10	15	20	25	30	35	40	45	50	75	100
12	60	67	74	81	88	95	-	-	-	-	-	-
16	58	67	76	85	94	103	-	-	-	-	-	-
20	103	117	131	145	159	173	187	201	215	229	-	-
25	137	152	167	182	197	212	227	242	257	272	-	-
32	203	223	243	263	283	303	323	343	363	383	403	423
40	215	238	261	284	307	330	353	376	399	422	445	468
50	-	381	418	455	492	529	566	603	640	677	714	751
63	-	550	592	634	676	718	760	802	844	886	928	970

Option Weights

Unit: g

Bore size (mm)	12	16	20	25	32	40	50	63
Both ends tapped	-	-	-	-	-	6	6	19
Rod end male thread	Male thread	1.5	3	6	12	26	27	53
	Nut	1	2	4	8	17	17	32
Rear boss mount	0.7	1.3	2	3	5	7	13	25
One-touch fitting	-	-	-	-	12	12	21	21
Foot (including bolt)	-	-	-	-	-	154	242	323
Front flange (including bolt)	-	-	-	-	-	213	372	558
Rear flange (including bolt)	-	-	-	-	-	198	348	534
Double clevis (pin, snap ring, bolt)	-	-	-	-	-	196	393	554

Calculation example: CQ2KD40-20D

- Basic weight: CQ2KA40-20D 284g
- Additional weight: Both ends tapped 6g
- Rod end male thread 44g
- Double clevis 196g

530g

Construction

Basic (ø12 to ø32)

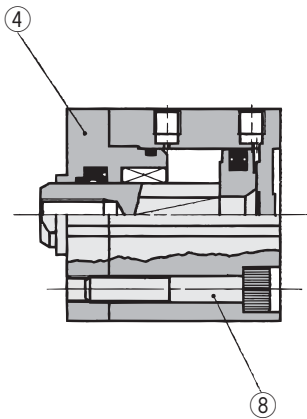

Rear boss mount

Basic (ø40 to ø63)

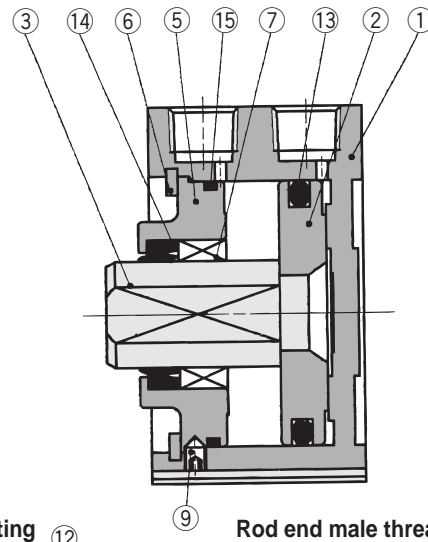

Rod end male thread

With One-touch fitting

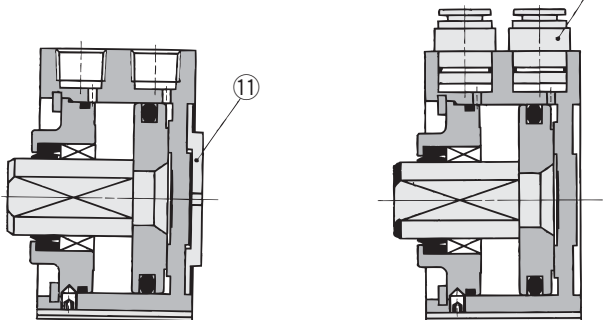

Component Parts

No.	Description	Material	Note
①	Cylinder tube	Aluminum alloy	Hard anodized
②	Piston	Aluminum alloy	Chromated
③	Piston rod	Stainless steel	ø12 to ø25
		Carbon steel	ø32 to ø100, Hard chrome plated
④	Rod cover	Brass	ø12, Nickel plated
		Aluminum alloy	ø16 to ø32, Anodized
⑤	Collar	Aluminum alloy	ø40 to ø63, Anodized
⑥	Snap ring	Carbon tool steel	Phosphate coating
⑦	Bushing	Oil impregnated sintered alloy	ø16 to ø63
⑧	Hex. socket head cap screw	Alloy steel	ø12 to ø32, Nickel plated
⑨	Hex. socket set screw	Alloy steel	ø40 to ø63, Nickel plated
⑩	Rod end nut	Carbon tool steel	Nickel plated
⑪	End boss ring	Aluminum alloy	ø20 to ø63, Hard anodized
⑫	One-touch fitting	-	ø32 to ø63

No.	Description	Material	Note
⑬	Piston seal	NBR	
⑭	Rod seal	NBR	
⑮	Tube gasket	NBR	

Replacement Parts: Seal Kits

Bore size (mm)	Kit No.	Note	Bore size (mm)	Kit No.	Note
12	CQ2KB12-PS	A set of above nos. ⑬, ⑭ and ⑮.	32	CQ2KB32-PS	A set of above nos. ⑬, ⑭ and ⑮.
16	CQ2KB16-PS		40	CQ2KB40-PS	
20	CQ2KB20-PS		50	CQ2KB50-PS	
25	CQ2KB25-PS		63	CQ2KB63-PS	

Compact Cylinder/Non-rotating Rod: Double Acting Single Rod **Series CQ2K**

Mounting Bolt for CQ2KB

Special bolt for through-hole mounting of CQ2KB is available as option.

How to Order: Specify the required bolts.
Example) Bolt M3 X 30 ℓ 2pcs.

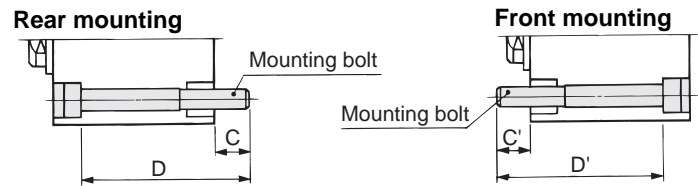

Model	C	D	Mounting bolt	C'	D'	Mounting bolt
CQ2KB12-5D		30	M3 X 30 ℓ		30	M3 X 30 ℓ
-10D	6.5	35	X 35 ℓ	6.5	35	X 35 ℓ
-15D		40	X 40 ℓ		40	X 40 ℓ
-20D		45	X 45 ℓ		45	X 45 ℓ
-25D		50	X 50 ℓ		50	X 50 ℓ
-30D		55	X 55 ℓ		55	X 55 ℓ
CQ2KB16-5D		30	M3 X 30 ℓ		30	M3 X 30 ℓ
-10D	5	35	X 35 ℓ	5	35	X 35 ℓ
-15D		40	X 40 ℓ		40	X 40 ℓ
-20D		45	X 45 ℓ		45	X 45 ℓ
-25D		50	X 50 ℓ		50	X 50 ℓ
-30D		55	X 55 ℓ		55	X 55 ℓ
CQ2KB20-5D		35	M5 X 35 ℓ		35	M5 X 35 ℓ
-10D	8	40	X 40 ℓ	9.5	40	X 40 ℓ
-15D		45	X 45 ℓ		45	X 45 ℓ
-20D		50	X 50 ℓ		50	X 50 ℓ
-25D		55	X 55 ℓ		55	X 55 ℓ
-30D		60	X 60 ℓ		60	X 60 ℓ
-35D		65	X 65 ℓ		65	X 65 ℓ
-40D		70	X 70 ℓ		70	X 70 ℓ
-45D		75	X 75 ℓ		75	X 75 ℓ
-50D		80	X 80 ℓ		80	X 80 ℓ
CQ2KB25-5D			40		M5 X 40 ℓ	
-10D	10	45	X 45 ℓ	6.5	40	X 40 ℓ
-15D		50	X 50 ℓ		45	X 45 ℓ
-20D		55	X 55 ℓ		50	X 50 ℓ
-25D		60	X 60 ℓ		55	X 55 ℓ
-30D		65	X 65 ℓ		60	X 60 ℓ
-35D		70	X 70 ℓ		65	X 65 ℓ
-40D		75	X 75 ℓ		70	X 70 ℓ
-45D		80	X 80 ℓ		75	X 75 ℓ
-50D		85	X 85 ℓ		80	X 80 ℓ
CQ2KB32-5D			40		M5 X 40 ℓ	
-10D	8.5	45	X 45 ℓ	10	45	X 45 ℓ
-15D		50	X 50 ℓ		50	X 50 ℓ
-20D		55	X 55 ℓ		55	X 55 ℓ
-25D		60	X 60 ℓ		60	X 60 ℓ
-30D		65	X 65 ℓ		65	X 65 ℓ
-35D		70	X 70 ℓ		70	X 70 ℓ
-40D		75	X 75 ℓ		75	X 75 ℓ
-45D		80	X 80 ℓ		80	X 80 ℓ
-50D		85	X 85 ℓ		85	X 85 ℓ
-75D		120	X 120 ℓ		120	X 120 ℓ
-100D	145	X 145 ℓ	145	X 145 ℓ		

Model	C	D	Mounting bolt	C'	D'	Mounting bolt
CQ2KB40-5D		35	M5 X 35 ℓ		35	M5 X 35 ℓ
-10D	7.5	40	X 40 ℓ	7.5	40	X 40 ℓ
-15D		45	X 45 ℓ		45	X 45 ℓ
-20D		50	X 50 ℓ		50	X 50 ℓ
-25D		55	X 55 ℓ		55	X 55 ℓ
-30D		60	X 60 ℓ		60	X 60 ℓ
-35D		65	X 65 ℓ		65	X 65 ℓ
-40D		70	X 70 ℓ		70	X 70 ℓ
-45D		75	X 75 ℓ		75	X 75 ℓ
-50D		80	X 80 ℓ		80	X 80 ℓ
-75D		115	X 115 ℓ		115	X 115 ℓ
-100D	140	X 140 ℓ	140	X 140 ℓ		
CQ2KB50-10D		45	M6 X 45 ℓ		45	M6 X 45 ℓ
-15D	12.5	50	X 50 ℓ	12.5	50	X 50 ℓ
-20D		55	X 55 ℓ		55	X 55 ℓ
-25D		60	X 60 ℓ		60	X 60 ℓ
-30D		65	X 65 ℓ		65	X 65 ℓ
-35D		70	X 70 ℓ		70	X 70 ℓ
-40D		75	X 75 ℓ		75	X 75 ℓ
-45D		80	X 80 ℓ		80	X 80 ℓ
-50D		85	X 85 ℓ		85	X 85 ℓ
-75D		120	X 120 ℓ		120	X 120 ℓ
-100D		145	X 145 ℓ		145	X 145 ℓ
CQ2KB63-10D		50	M8 X 50 ℓ		50	M8 X 50 ℓ
-15D	14.5	55	X 55 ℓ	14.5	55	X 55 ℓ
-20D		60	X 60 ℓ		60	X 60 ℓ
-25D		65	X 65 ℓ		65	X 65 ℓ
-30D		70	X 70 ℓ		70	X 70 ℓ
-35D		75	X 75 ℓ		75	X 75 ℓ
-40D		80	X 80 ℓ		80	X 80 ℓ
-45D		85	X 85 ℓ		85	X 85 ℓ
-50D		90	X 90 ℓ		90	X 90 ℓ
-75D		125	X 125 ℓ		125	X 125 ℓ
-100D		150	X 150 ℓ		150	X 150 ℓ

CUJ

CU

CQS

CQ2

RQ

MU

Copper Free

20 — CQ2KB Bore size Stroke D (M)

• Copper Free Series • $\phi 16, \phi 20, \phi 25, \phi 32, \phi 40, \phi 50, \phi 63$

To eliminate influences of copper ions or halogen ions during CRT manufacturing processes, copper and fluorine materials are not used as component parts.

Specifications

Action	Double acting single rod
Cylinder bore size	$\phi 16, \phi 20, \phi 25, \phi 32, \phi 40, \phi 50, \phi 63$
Proof pressure	1.5MPa
Max. operating pressure	1.0MPa
Rubber bumper	None
Piping	Screw-in piping
Piston speed	50 to 500mm/s
Mounting	Through-hole
Auto switch	Mountable

Series CDQ2K Auto Switch Specifications



* Refer to p.5.3-2 for details of auto switch.



Minimum Strokes for Auto Switch Mounting

(mm)

Number of auto switches	D-F7□V D-J79C D-F9□V	D-A7□ D-A80 D-A73C D-A80C D-A9□V	D-F7□WV D-F9□WV	D-A7□H D-A80H D-F7□ D-J79 D-F9B D-F9P D-F9□W	D-A79W	D-F7□W D-J79W D-F7BAL D-F79F D-F9BAL	D-F7LF	D-A9□ D-F9N
1	5	5	10	15	15	20	25	10
2	5	10	15	15	20	20	25	10

Weight

Unit: g

Bore (mm)	Cylinder stroke (mm)											
	5	10	15	20	25	30	35	40	45	50	75	100
12	77	83	89	95	101	107	-	-	-	-	-	-
16	86	94	102	110	118	126	-	-	-	-	-	-
20	138	152	166	180	194	208	222	236	250	264	-	-
25	178	194	210	226	242	258	274	290	306	322	-	-
32	236	256	276	296	316	336	356	376	396	416	516	616
40	253	276	299	322	345	368	391	414	437	460	575	690
50	-	464	501	538	575	612	649	686	723	760	945	1130
63	-	654	696	738	780	822	864	906	948	990	1200	1410

Option Weights

Unit: g

Bore size (mm)	12	16	20	25	32	40	50	63
Both ends tapped	-	-	-	-	-	6	6	19
Rod end male thread	Male thread	1.5	3	6	12	26	27	53
	Nut	1	2	4	8	17	17	32
Rear boss mount	0.7	1.3	2	3	5	7	13	25
With One-touch fitting	-	-	-	-	12	12	21	21
Foot (including mounting bolt)	-	-	-	-	-	154	242	323
Front flange (including mounting bolt)	-	-	-	-	-	213	372	558
Rear flange (including mounting bolt)	-	-	-	-	-	198	348	534
Double clevis (including pin, snap ring and bolt)	-	-	-	-	-	196	393	554

Calculation example: CDQ2KD40-25DM

- Basic weight: CDQ2KB40-25D.....345g
- Additional weight: Both ends tapped.....6g
- Rod end male thread.....44g
- Double clevis196g

591g

When auto switch is mounted, add the weight of number of auto switches and mounting brackets.

Weight/Auto Switch Mounting Bracket

Part No.	Bore size	Weight g
BQ-1	ø12 to ø25	1.5
BQ-2	ø32 to ø63	1.5

* Refer to p.5.3-75 for auto switch weight.

Construction

ø12 to ø25

ø32

ø40 to ø63

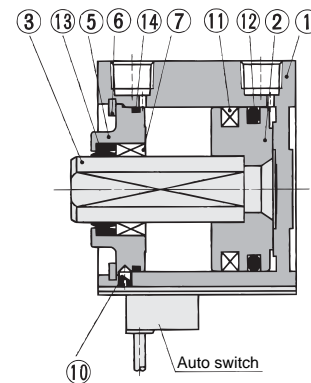
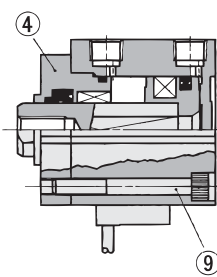
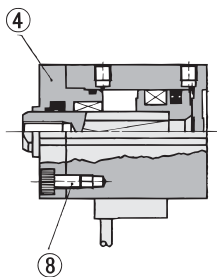

Component Parts

No.	Description	Material	Note
①	Cylinder tube	Aluminum alloy	Hard anodized
②	Piston	Aluminum alloy	Chromated
③	Piston rod	Stainless steel	ø12 to ø25
		Carbon steel	ø32 to ø63, Hard chrome plated
④	Rod cover	Brass	ø12, Nickel plated
		Aluminum alloy	ø16 to ø32, Anodized
⑤	Collar	Aluminum alloy	ø40 to ø63, Anodized
⑥	Snap ring	Carbon tool steel	Phosphate coating
⑦	Bushing	Oil impregnated sintered alloy	ø16 to ø63
⑧	Bolt with hex. hole	Alloy steel	ø12 to ø25, Nickel plated
⑨	Bolt with hex. hole	Alloy steel	ø32, Nickel plated
⑩	Set screw with hex. hole	Alloy steel	Nickel plated, ø40 to ø63
⑪	Magnet	-	
⑫	Piston seal	NBR	
⑬	Rod seal	NBR	
⑭	Tube gasket	NBR	

Replacement Parts: Pneumatic (Non-lube)

Bore size (mm)	Kit No.	Contents
12	CQ2KB12-PS	Kits include items ⑫, ⑬ and ⑭ from the left table.
16	CQ2KB16-PS	
20	CQ2KB20-PS	
25	CQ2KB25-PS	
32	CQ2KB32-PS	
40	CQ2KB40-PS	
50	CQ2KB50-PS	
63	CQ2KB63-PS	

* Seal kits consist of items ⑫, ⑬ and ⑭ contained in one kit, and can be ordered using the order number for each tube bore size.

Compact Cylinder/Non-rotating Rod: Double Acting Single Rod *Series CDQ2K*

Mounting Bolt for CDQ2KB with Auto Switch

Special long bolt for through-hole mounting of CDQ2KB is available.

How to Order: Specify the required bolts

Example) Bolt M3 X 35 ℓ 2pcs.

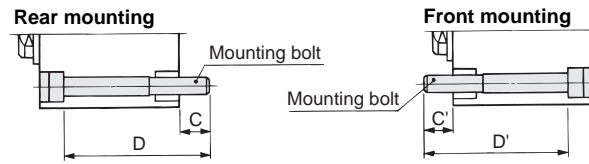

Model	C	D	Mounting bolt	C'	D'	Mounting bolt
CDQ2KB12-5DC	5.5	35	M3 X 35 ℓ	5.5	40	M3 X 40 ℓ
-10DC		40	X 40 ℓ		45	X 45 ℓ
-15DC		45	X 45 ℓ		50	X 50 ℓ
-20DC		50	X 50 ℓ		55	X 55 ℓ
-25DC		55	X 55 ℓ		60	X 60 ℓ
-30DC		60	X 60 ℓ		65	X 65 ℓ
CDQ2KB16-5D	8	40	M3 X 40 ℓ	8	45	M3 X 45 ℓ
-10D		45	X 45 ℓ		50	X 50 ℓ
-15D		50	X 50 ℓ		55	X 55 ℓ
-20D		55	X 55 ℓ		60	X 60 ℓ
-25D		60	X 60 ℓ		65	X 65 ℓ
-30D		65	X 65 ℓ		70	X 70 ℓ
CDQ2KB20-5D	10.5	40	M5 X 40 ℓ	7.5	45	M5 X 45 ℓ
-10D		45	X 45 ℓ		50	X 50 ℓ
-15D		50	X 50 ℓ		55	X 55 ℓ
-20D		55	X 55 ℓ		60	X 60 ℓ
-25D		60	X 60 ℓ		65	X 65 ℓ
-30D		65	X 65 ℓ		70	X 70 ℓ
CDQ2KB25-5D	9.5	40	M5 X 40 ℓ	6.5	45	M5 X 45 ℓ
-10D		45	X 45 ℓ		50	X 50 ℓ
-15D		50	X 50 ℓ		55	X 55 ℓ
-20D		55	X 55 ℓ		60	X 60 ℓ
-25D		60	X 60 ℓ		65	X 65 ℓ
-30D		65	X 65 ℓ		70	X 70 ℓ
CDQ2KB32-5D	8.5	50	M5 X 50 ℓ	10	50	M5 X 50 ℓ
-10D		55	X 55 ℓ		55	X 55 ℓ
-15D		60	X 60 ℓ		60	X 60 ℓ
-20D		65	X 65 ℓ		65	X 65 ℓ
-25D		70	X 70 ℓ		70	X 70 ℓ
-30D		75	X 75 ℓ		75	X 75 ℓ

Model	C	D	Mounting bolt	C'	D'	Mounting bolt
CDQ2KB32-40D	8.5	85	M5 X 85 ℓ	10	85	M5 X 85 ℓ
-45D		90	X 90 ℓ		90	X 90 ℓ
-50D		95	X 95 ℓ		95	X 95 ℓ
-75D		120	X 120 ℓ		120	X 120 ℓ
-100D		145	X 145 ℓ		145	X 145 ℓ
CDQ2KB40-5D		7.5	45		M5 X 45 ℓ	7.5
-10D	50		X 50 ℓ	50	X 50 ℓ	
-15D	55		X 55 ℓ	55	X 55 ℓ	
-20D	60		X 60 ℓ	60	X 60 ℓ	
-25D	65		X 65 ℓ	65	X 65 ℓ	
-30D	70		X 70 ℓ	70	X 70 ℓ	
CDQ2KB50-10D	12.5	55	M6 X 55 ℓ	12.5	55	M6 X 55 ℓ
-15D		60	X 60 ℓ		60	X 60 ℓ
-20D		65	X 65 ℓ		65	X 65 ℓ
-25D		70	X 70 ℓ		70	X 70 ℓ
-30D		75	X 75 ℓ		75	X 75 ℓ
-35D		80	X 80 ℓ		80	X 80 ℓ
CDQ2KB63-10D	14.5	85	X 85 ℓ	14.5	85	X 85 ℓ
-45D		90	X 90 ℓ		90	X 90 ℓ
-50D		95	X 95 ℓ		95	X 95 ℓ
-75D		120	X 120 ℓ		120	X 120 ℓ
-100D		145	X 145 ℓ		145	X 145 ℓ
CDQ2KB63-10D		14.5	60		M8 X 60 ℓ	14.5
-15D	65		X 65 ℓ	65	X 65 ℓ	
-20D	70		X 70 ℓ	70	X 70 ℓ	
-25D	75		X 75 ℓ	75	X 75 ℓ	
-30D	80		X 80 ℓ	80	X 80 ℓ	
-35D	85		X 85 ℓ	85	X 85 ℓ	
-40D	90	X 90 ℓ	90	X 90 ℓ		
-45D	95	X 95 ℓ	95	X 95 ℓ		
-50D	100	X 100 ℓ	100	X 100 ℓ		
-75D	125	X 125 ℓ	125	X 125 ℓ		
-100D	150	X 150 ℓ	150	X 150 ℓ		

Auto Switch Mounting Bracket Part No.

Bore size (m)	Part No.	Note	Applicable switch	
			Reed switch	Solid state switch
12/16 20/25	BQ-1	<ul style="list-style-type: none"> Switch mounting (M3 X 0.5 X 8 ℓ) Square nut 	D-A7□, A80	D-F7□, J79 D-F7□V D-J79C
32/40 50/63	BQ-2	<ul style="list-style-type: none"> Switch mounting (M3 X 0.5 X 10 ℓ) Switch spacer Switch mounting nut 	D-A73C, A80C D-A7□H, A80H D-A79W	D-F7□W, J79W D-F7□WV D-F7BAL D-F7□F D-F7NTL

[Mounting screw set made by stainless steel]

Following stainless steel mounting screw set (included nut) is provided. Use them in accordance with environment.

(Auto switch interface is not included. Order it separately)

BBA2: For D-A7/A8/F7/J7

When D-F7BAL mounted on cylinder is required, the stainless steel screw mentioned above is used at shipping. When auto switch unit is shipped, BBA4 is attached.

CUJ

CU

CQS

CQ2

RQ

MU

Series CDQ2K

Auto Switch Mounting Position (at Stroke End) and Mounting Height

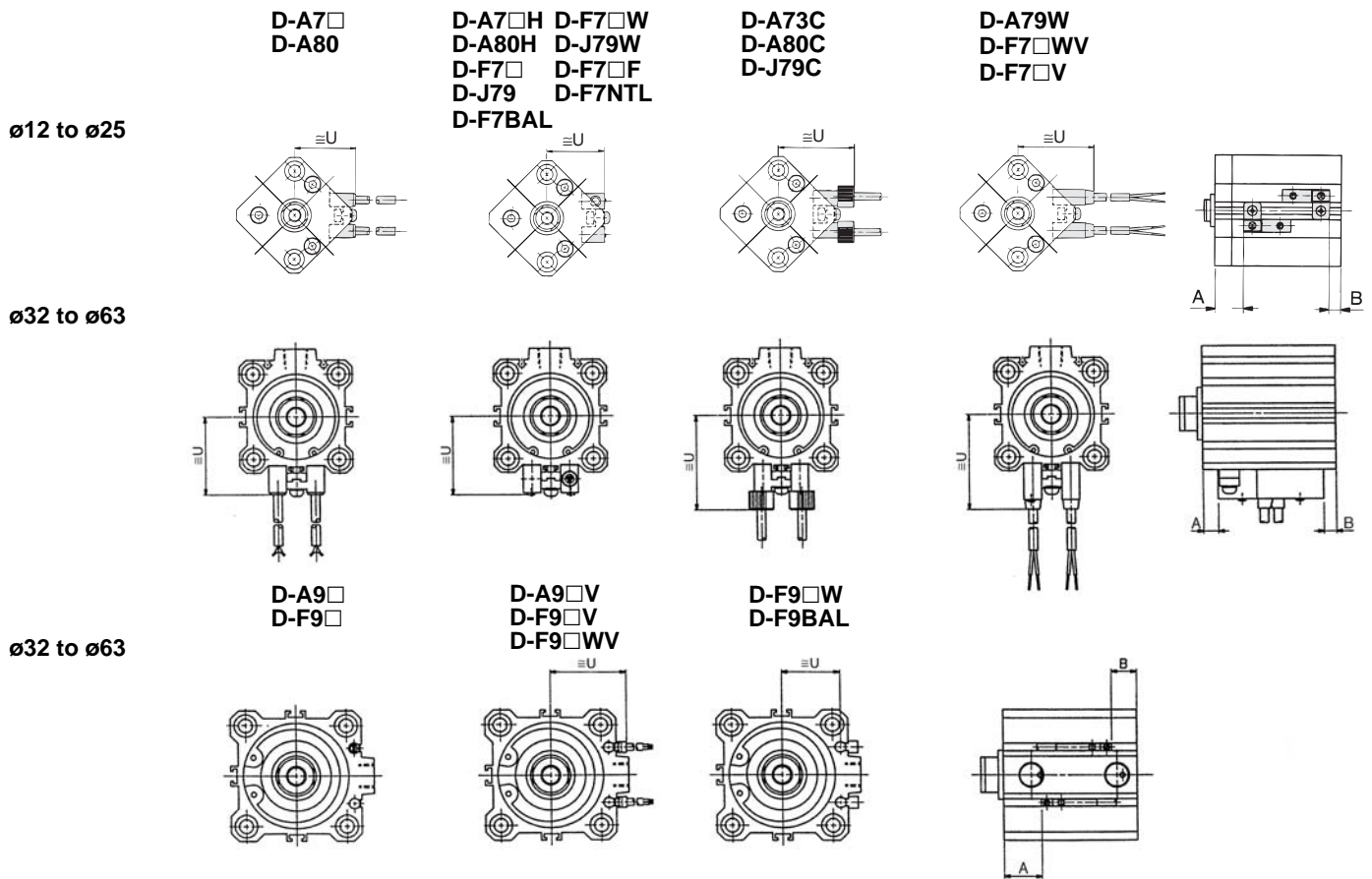

Auto Switch Mounting Position

(mm)

Bore (mm)	D-A7□ D-A80		D-A7□H/A80H D-A73C/A80C D-F7□/D-J79/F7□V D-J79C		D-A79W		D-F7BAL D-F7□W D-F7□F D-J79W D-F7□WV		D-A9□ D-A9□V		D-F9□ D-F9□V		D-F9□W D-F9□WV D-F9BAL	
	A	B	A	B	A	B	A	B	A	B	A	B	A	B
12	9.5	5.5	10	6	7	3	14	10	—	—	—	—	—	—
16	12.5	5	13	5.5	10	2.5	17	9.5	—	—	—	—	—	—
20	15.5	6.5	16	7	13	4	20	11	—	—	—	—	—	—
25	15.5	7	16	7.5	13	4.5	20	11.5	—	—	—	—	—	—
32	18	6	18.5	6.5	15.5	3.5	22.5	10.5	17	5	21	9	20	8
40	13	8.5	13.5	9	10.5	6	17.5	13	12	7.5	16	11.5	15	10.5
50	11	11.5	11.5	12	8.5	9	15.5	16	10	10.5	14	14.5	13	13.5
63	13.5	14.5	14	15	11	12	18	19	12.5	13.5	16.5	17.5	15.5	16.5

Auto Switch Mounting Height

(mm)

D-A7□ D-A80	D-A7□H/A80H/F7□ D-J79/F7□W/J79W D-F7BAL/F7□F/F7NTL	D-A73C D-A80C	D-F7□V D-F7□WV	D-J79C	D-A79W	D-A9□V	D-F9□V D-F9□WV	D-F9□W D-F9BAL
U	U	U	U	U	U	U	U	U
19.5	20.5	26.5	23	26	22	—	—	—
22.5	23.5	29.5	26	29	25	—	—	—
24.5	25.5	31.5	28	31	27	—	—	—
27.5	28.5	34.5	31	34	30	—	—	—
31.5	32.5	38.5	35	38	34	27	29	26.5
35	36	42	38.5	41.5	37.5	30.5	32.5	30
41	42	48	44.5	47.5	43.5	36.5	38.5	36
47.5	48.5	54.5	51	54	50	40	42	39.5

CUJ

CU

CQS

CQ2

RQ

MU

Series CQ2K

ø12 to ø25 Without Auto Switch

Standard (Through-hole)/CQ2KB

ø12, ø16

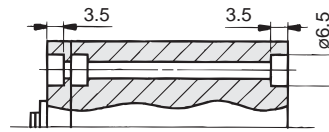

ø20, ø25

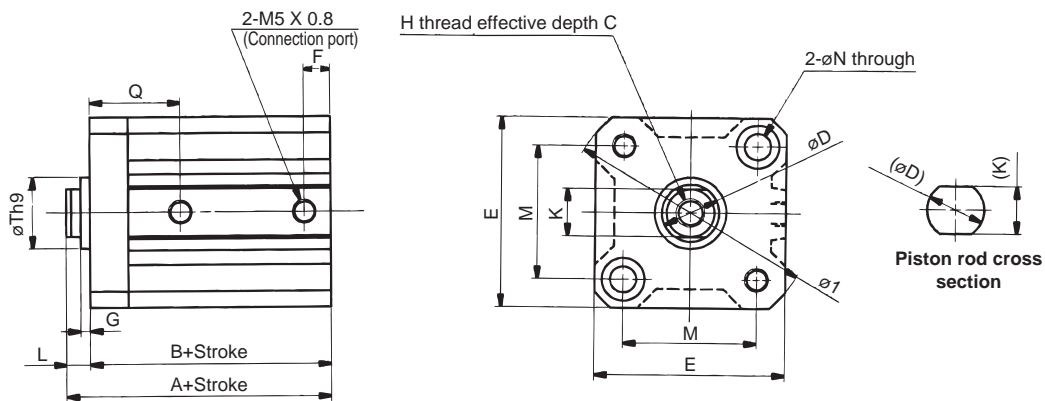
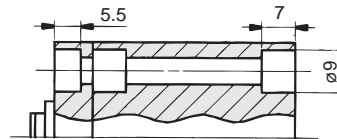

Rear boss mount

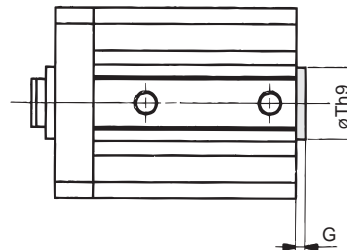

Rear boss mount (mm)

Bore (mm)	G	Th9
12	1.5	15 ⁰ _{-0.043}
16	1.5	20 ⁰ _{-0.052}
20	2	13 ⁰ _{-0.043}
25	2	15 ⁰ _{-0.043}

Rod end male thread

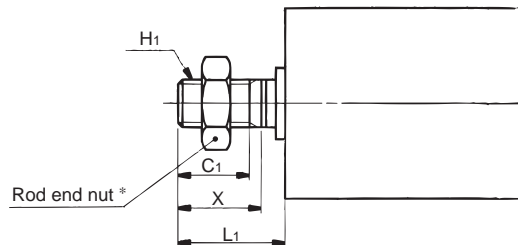

Rod end male thread (mm)

Bore (mm)	C ₁	H ₁	L ₁	X
12	9	M5 X 0.8	14	10.5
16	10	M6 X 1.0	15.5	12
20	12	M8 X 1.25	18.5	14
25	15	M10 X 1.25	22.5	17.5

Standard

(mm)

Bore (mm)	Stroke range (mm)	A	B	C	D	E	F	G	H	I	K	L	M	N	Q	Th9
12	5 to 30	25.5	22	6	6	25	5	1.5	M3 X 0.5	32	5.2	3.5	15.5	3.5	12.5	15 ⁰ _{-0.043}
16	5 to 30	27	23.5	8	8	29	5.5	1.5	M4 X 0.7	38	6	3.5	20	3.5	13	20 ⁰ _{-0.052}
20	5 to 50	32	27.5	7	10	36	5.5	2	M5 X 0.8	47	8	4.5	25.5	5.5	17	13 ⁰ _{-0.043}
25	5 to 50	35.5	30.5	12	12	40	5.5	2	M6 X 1.0	52	10	5	28	5.5	19	15 ⁰ _{-0.043}

* Refer to p.2.3-18 & 19 for details of rod end nut and optional bracket.

Compact Cylinder/Non-rotating Rod: Double Acting Single Rod **Series CDQ2K**

ø12 to ø25 With Auto Switch

Standard (Through-hole)/CDQ2KB

ø12, ø16

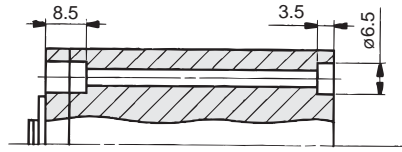

ø20, ø25

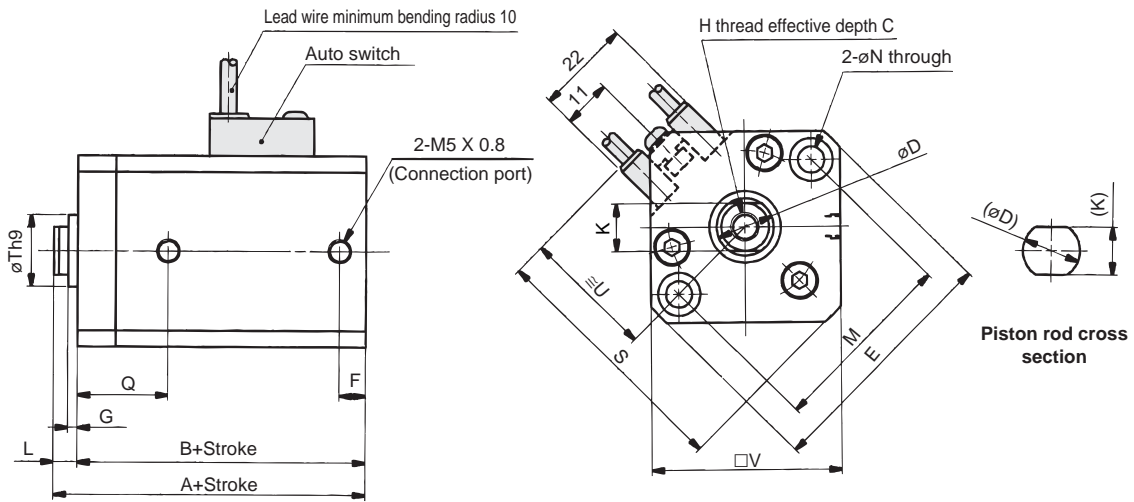
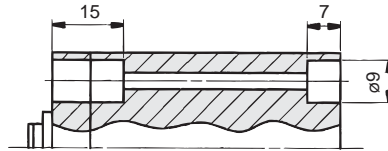

Rear boss mount

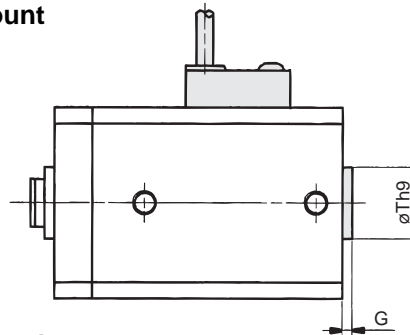

Rod end male thread

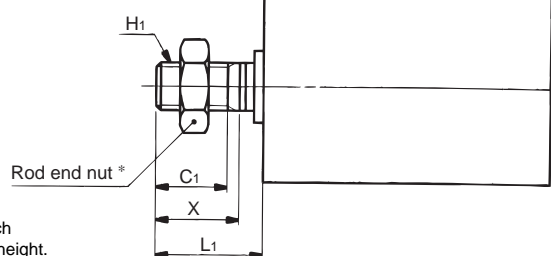

* Above auto switch: D-A73/A80.
Refer to p.2.3-62 for of auto switch mounting position and mounting height.

Rod end male thread (mm)

Bore (mm)	C1	H1	L1	X
12	9	M5 X 0.8	14	10.5
16	10	M6 X 1.0	15.5	12
20	12	M8 X 1.25	18.5	14
25	15	M10 X 1.25	22.5	17.5

Standard

Bore (mm)	Stroke range (mm)	A	B	C	D	E	F	G	H	K	L	M	N	Q	S	Th9	U	V
12	5 to 30	36.5	33	6	6	32	6.5	1.5	M3 X 0.5	5.2	3.5	22	3.5	16	35.5	15 ⁰ _{-0.043}	19.5	25
16	5 to 30	39	35.5	8	8	38	5.5	1.5	M4 X 0.7	6	3.5	28	3.5	15	41.5	20 ⁰ _{-0.052}	22.5	29
20	5 to 50	44	39.5	7	10	47	5.5	2	M5 X 0.8	8	4.5	36	5.5	18.5	48	13 ⁰ _{-0.043}	24.5	36
25	5 to 50	45.5	40.5	12	12	52	5.5	2	M6 X 1.0	10	5	40	5.5	19	53.5	15 ⁰ _{-0.043}	27.5	40

* Refer to p.2.3-18 & 19 for rod end nut and optional bracket.

CUJ

CU

CQS

CDQ2

RQ

MU

Series CQ2K

ø32 Without Auto Switch

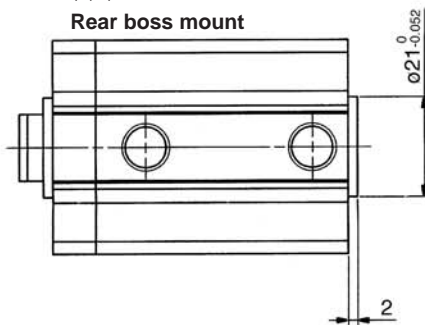
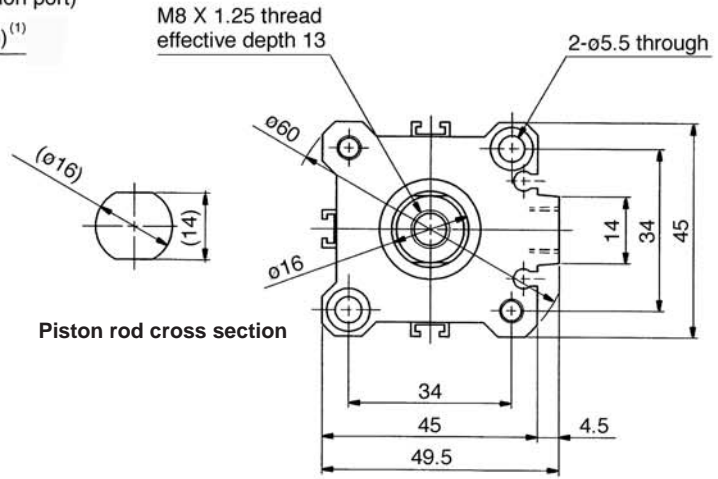
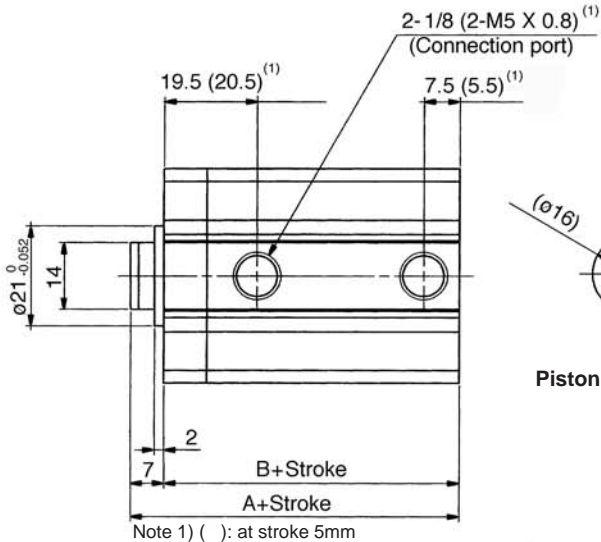
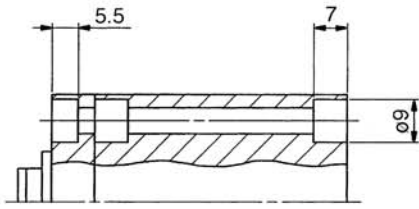

	(mm)	
Stroke range	A	B
5 to 50	39	32
75, 100	49	42

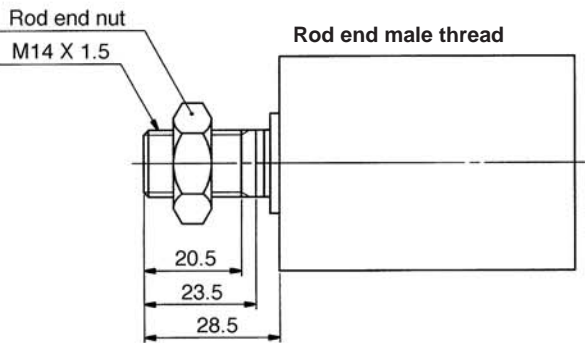

With built-in One-touch Fitting/ø32

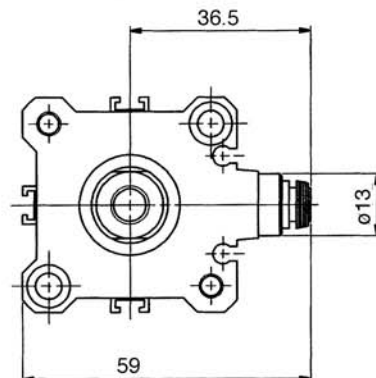
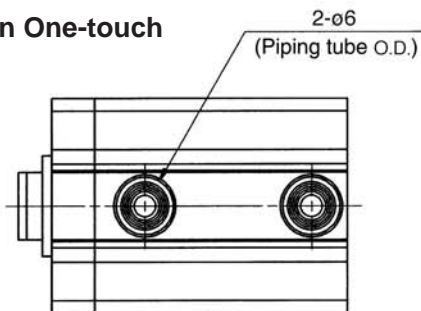

When with built-in auto switch is required, dimensions of 5 stroke are same as 10 stroke.
* Refer to p.2.3-18 & 19 for details of rod end nut and optional bracket.

Compact Cylinder/Non-rotating Rod: Double Acting Single Rod *Series CDQ2K*

Ø32 With Auto Switch

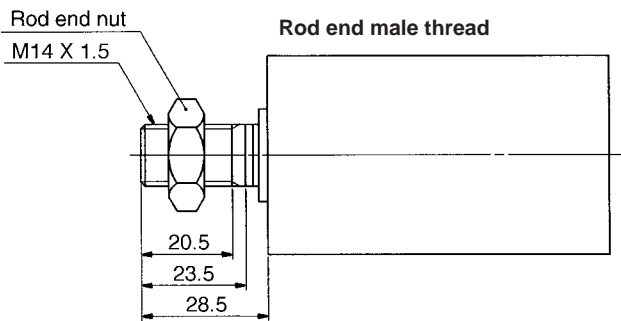
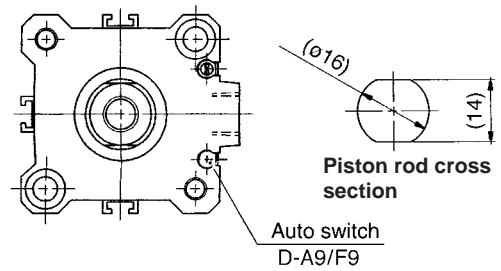
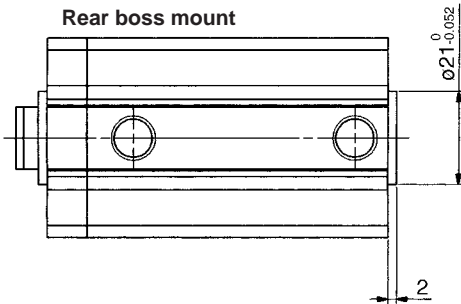
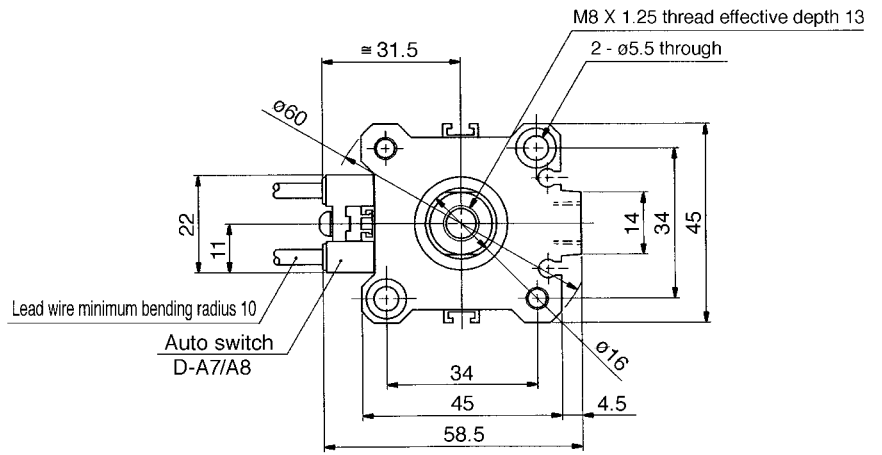
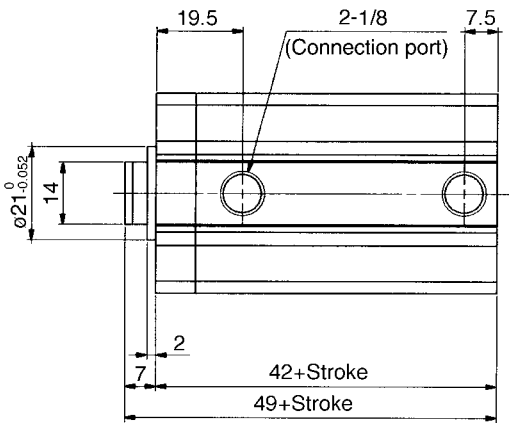
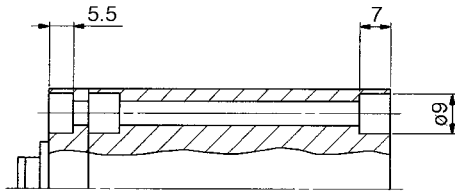

With built-in One-touch fitting/Ø32

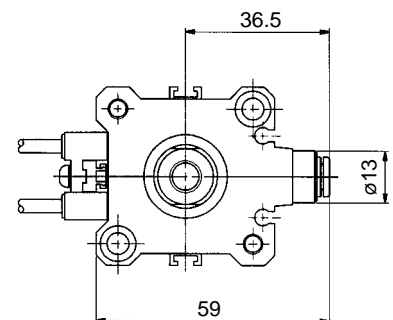
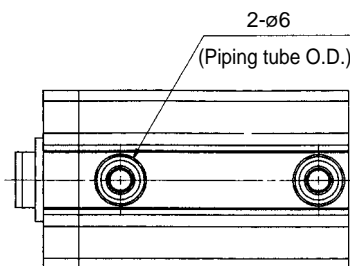

CUJ

CU

CQS

CQ2

RQ

MU

* Refer to p.2.3-18 & 19 for details of rod end nut and optional bracket.

Series CQ2K/CDQ2K

ø40 to ø63 With Auto Switch

(For those without auto switches, refer to dimensions table because dimensions of A and B vary.)

Standard (Through-hole)/CDQ2KB

Both ends tapped: CDQ2KA

Both ends tapped (mm)

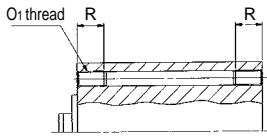

Bore (mm)	O ₁	R
40	M6 X 1.0	10
50	M8 X 1.25	14
63	M10 X 1.5	18

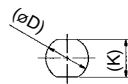
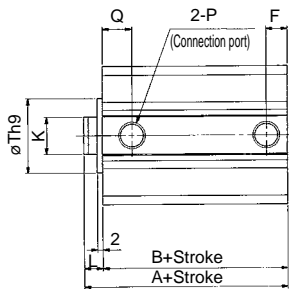

Piston rod cross section

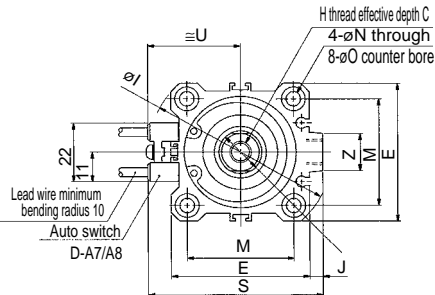

Rear boss mount

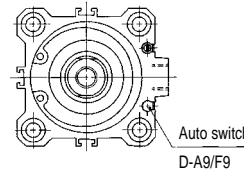
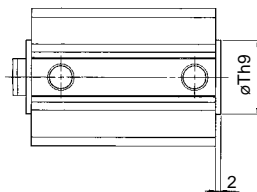

Rear boss mount (mm)

Bore (mm)	Th9
40	28 ⁰ _{-0.052}
50	35 ⁰ _{-0.062}
63	35 ⁰ _{-0.062}

Rod end male thread

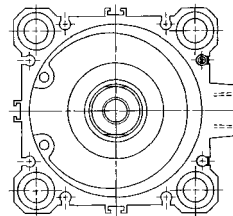
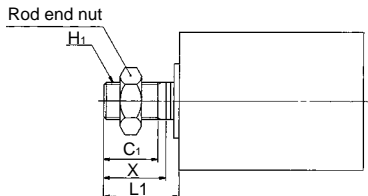

ø63 Cylinder tube form

Rod end male thread (mm)

Bore (mm)	C ₁	H ₁	L ₁	X
40	20.5	M14 X 1.5	28.5	23.5
50	26	M18 X 1.5	33.5	28.5
63	26	M18 X 1.5	33.5	28.5

With built-in One-touch fitting

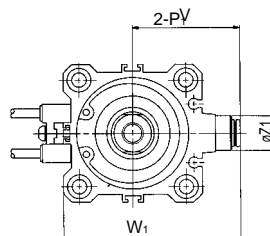
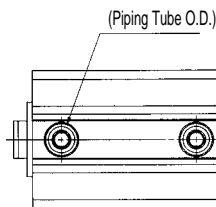

With built-in One-touch fitting (mm)

Bore (mm)	Z ₁	P ₁	V	W ₁
40	13	6	40.5	66.5
50	16	8	50	82
63	16	8	56.5	95

Standard

Bore size (mm)	Stroke range (mm)	W/o auto switch		With auto switch		C	D	E	F	H	I	J	K	L	M	N	O	P	Q	S	Th9	U	Z
		A	B	A	B																		
40	5 to 50	36.5	29.5	46.5	39.5	13	16	52	8	M8 X 1.25	69	5	14	7	40	5.5	9 Depth 7	1/8	11	66	28 ⁰ _{-0.052}	35	14
	75, 100	46.5	39.5																				
50	10 to 50	38.5	30.5	48.5	40.5	15	20	64	10.5	M10 X 1.5	86	7	18	8	50	6.6	11 Depth 8	1/4	10.5	80	35 ⁰ _{-0.062}	41	19
	75, 100	48.5	40.5																				
63	10 to 50	44	36	54	46	15	20	77	10.5	M10 X 1.5	103	7	18	8	60	9	14 Depth 10.5	1/4	15	93	35 ⁰ _{-0.062}	47.5	19
	75, 100	54	46																				



* Refer to p.2.3-18 & 19 for details of rod end nut and optional brackets.

Compact Cylinder/Non-rotating Rod: Double Acting Single Rod *Series CDQ2K*

Foot/CQ2KL, CDQ2KL

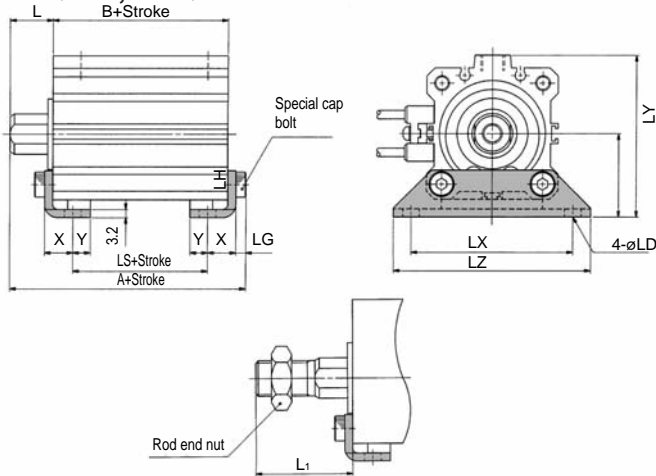

Foot

Bore (mm)	Stroke (mm)	W/o auto switch			With auto switch			L	L ₁	LD	LG	LH	LX	LY
		A	B	LS	A	B	LS							
40	5 to 50	53.7	29.5	13.5	63.7	39.5	23.5	17	38.5	6.6	4	33	64	64
	75, 100	63.7	39.5	23.5										
50	10 to 50	56.7	30.5	7.5	66.7	40.5	17.5	18	43.5	9	5	39	79	78
	75, 100	66.7	40.5	17.5										
63	10 to 50	62.2	36	10	72.2	46	20	18	43.5	11	5	46	95	91.5
	75, 100	72.2	46	20										

Bore (mm)	LZ	X	Y
40	78	11.2	7
50	95	14.7	8
63	113	16.2	9

Front flange/CQ2KF, CDQ2KF

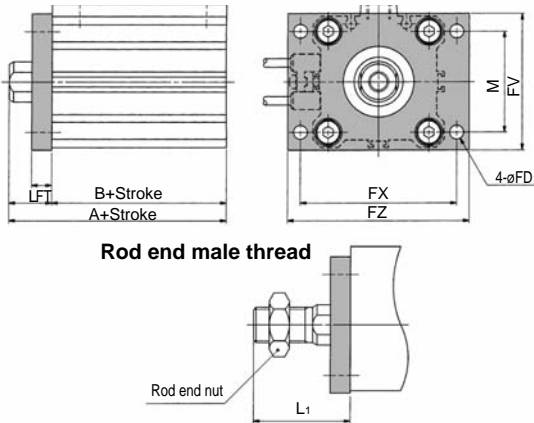

Front flange

Bore (mm)	Stroke (mm)	W/o auto switch		With auto switch		FD	FT	FV	FX	FZ	L	L ₁	M
		A	B	A	B								
40	5 to 50	46.5	29.5	56.5	39.5	5.5	8	54	62	72	17	38.5	40
	75, 100	56.5	39.5										
50	10 to 50	48.5	30.5	58.5	40.5	6.6	9	67	76	89	18	43.5	50
	75, 100	58.5	40.5										
63	10 to 50	54	36	64	46	9	9	80	92	108	18	43.5	60
	75, 100	64	46										

Rear flange/CQ2KG, CDQ2KG

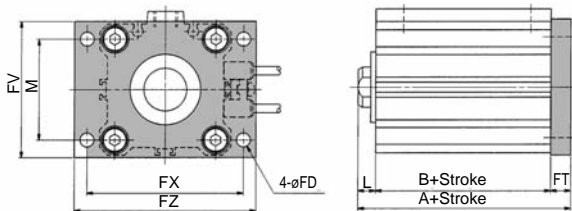

Rear flange

Bore (mm)	Stroke (mm)	W/o auto switch		With auto switch		L	L ₁
		A	B	A	B		
40	5 to 50	44.5		54.5		7	28.5
	75, 100	54.5					
50	10 to 50	47.5		57.5		8	33.5
	75, 100	57.5					
63	10 to 50	53		63		8	33.5
	75, 100	63					

(* Dimensions except A, L and L₁ are same as front flange type.)

Rod end male thread

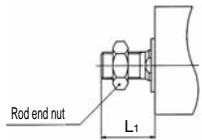

Double clevis/CQ2KD, CDQ2KD

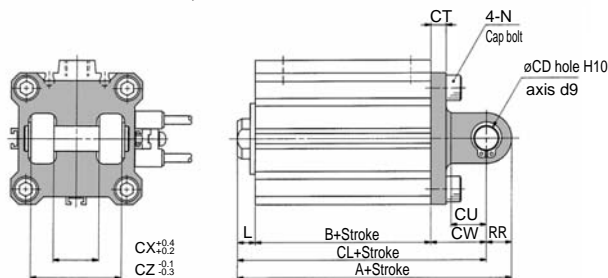

Double clevis

Bore (mm)	Stroke (mm)	Without auto switch			With auto switch			CD	CT	CU	CW	CX	CZ	L	L ₁
		A	B	CL	A	B	CL								
40	5 to 50	68.5	29.5	58.5	78.5	39.5	68.5	10	6	14	22	18	36	7	28.5
	75, 100	78.5	39.5	68.5											
50	10 to 50	80.5	30.5	66.5	90.5	40.5	76.5	14	7	20	28	22	44	8	33.5
	75, 100	90.5	40.5	76.5											
63	10 to 50	88	36	74	98	46	84	14	8	20	30	22	44	8	33.5
	75, 100	98	46	84											

* Refer to p.2.3-18 & 19 for details of rod end nut and optional brackets.

** Clevis pin and snap ring are packed with double clevis type.

Bore (mm)	N	RR
40	M6 X 1.0	10
50	M8 X 1.25	14
63	M10 X 1.5	14

Rod end male thread

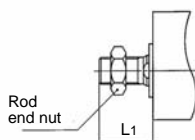

CUJ

CU

CQS

CQ2

RQ

MU

Compact Cylinder/Non-rotating Rod: Double Acting Double Rod

Series CQ2KW

ø12, ø16, ø20, ø25, ø32, ø40, ø50, ø63

How to Order

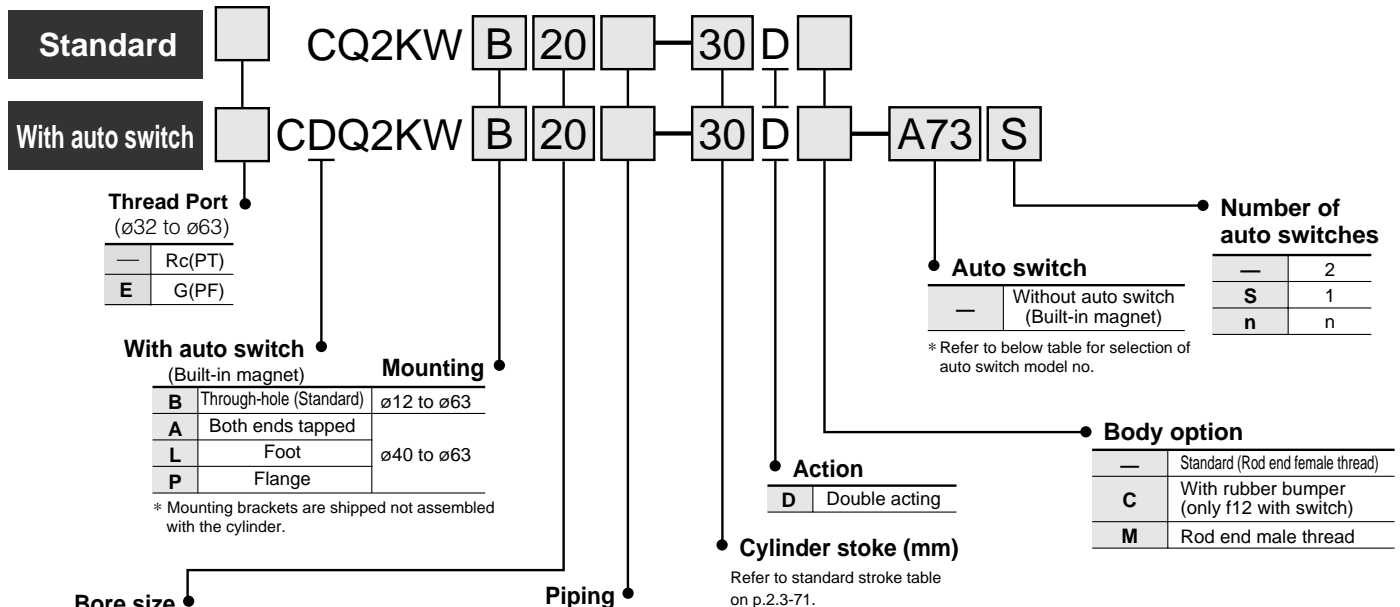

Applicable Auto Switches/Refer to p.5.3-2 for further information on auto switch.

Style	Special function	Electrical entry	Indicator	Wiring (Output)	Load voltage		Rail mounting		Direct mounting		Lead wire (m) *				Applicable load																																									
					DC	AC	ø12 to ø63		ø32 to ø63		0.5 (—)	3 (L)	5 (Z)	None (N)																																										
							Perp.	In-line	Perp.	In-line																																														
Reed switch	—	Grommet	Yes	3 wire (Equiv. NPN)	—	5V	—	A76H	A96V	A96	●	●	—	—	IC																																									
																24V	200V	A72	A72H	—	—	●	●	—	—																															
																										12V	100V	A73	A73H	—	—	●	●	—	—																					
																																				5V, 12V	≤100V	A80	A80H	A90V	A90	●	●	—	—											
																																														12V	—	A73C	—	—	—	●	●	●	—	
																																																								5V, 12V
—	—	A79W	—	—	—	●	●	—	—																																															
										Solid state switch	—	Grommet	Yes	3 wire (NPN)	5V, 12V	—	F7NV	F79	—	—	●	●	○	—	IC																															
																										24V	12V	—	—	F9NV	F9N	●	●	—	—																					
																																				5V, 12V	—	F7PV	F7P	—	—	●	●	○	—											
																																														12V	—	—	—	F9PV	F9P	●	●	—	—	
																																																								5V, 12V
12V	—	—	—	F9BV	F9B	●	●	—	—																																															
										5V, 12V	—	—	—	—	—	●	●	●	—																																					
																				5V, 12V	—	—	—	—	—	●	●	○	—																											
																														12V	—	—	—	F7NVV	F79W	●	●	○	—																	
																																								5V, 12V	—	—	—	F9NVV	F9NW	●	●	○	—							
																																																		5V, 12V	—	—	—	F7PW	—	●
12V	—	—	—	F9PVV	F9PW	●	●	○	—																																															
										5V, 12V	—	—	—	F7BWV	J79W	F9BWW	F9BW	●	●																																					
																				—	—	—	—	F7BA	—	F9BA	—	●	○																											
																														5V, 12V	—	—	—	—	—	—	—	●	○																	
																																								—	—	—	—	F7NT	—	—	—	●	○							
																																																		—	—	—	—	F79F	—	—
—	—	—	—	—	—	—	—	●	●																																															

* Lead wire length 0.5m..... — Example) A80C 5m..... Z Example) A80CZ
3m..... L Example) A80CL None..... N Example) A80CN

* Solid state switches marked with a "○" are manufactured receipt of order.

Compact Cylinder/Non-rotating Rod: Double Acting Double Rod *Series CQ2KW*



Style

Bore size (mm)		12	16	20	25	32	40	50	63	
Pneumatic	Mounting	Through-hole (Standard)	●	●	●	●	●	●	●	
		Both ends tapped	—	—	—	—	—	●	●	
	Built-in magnet		●	●	●	●	●	●	●	
	Piping	Screw-in style	M5 X 0.8	M5 X 0.8	M5 X 0.8	M5 X 0.8	M5 X 0.8 ⁽¹⁾ 1/8	1/8	1/4	1/4
		One-touch fitting	—	—	—	—	ø6/4 ⁽²⁾	ø6/4	ø8/6	ø8/6
Rod end male thread		●	●	●	●	●	●	●	●	

Note 1) Without auto switch: M5 X 0.8

Note 2) When the style with built-in fitting is required, dimensions of ø32, 5 stroke are same as 10 stroke.

Symbol

Non-rotating rod/Double Rod

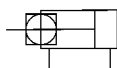

Made to Order

Refer to p.5.4-1 for made to order specifications of CQ2KW series.

⚠ Precautions

Be sure to read before handling. Refer to p.0-39 to 0-46 for Safety Instructions and common precautions.

⚠ Caution

Snap Ring Installation/Removal

- For installation and removal, use an appropriate pair of pliers (tool for installing a C snap ring).
- Exercise caution even when using an appropriate pair of pliers (tool for installing a C snap ring), because of the possibility of the snap ring becoming detached from the tip of the pliers (tool for installing a C snap ring) and flying away, which could injure humans or damage the peripheral equipment. After installing the snap ring, make sure that it is placed securely in the ring groove before supplying air.

Mounting

- When removing a load, be sure to secure the wrench flats of the piston rod on the load side.
- If this is done without securing the piston rod on the load side, be aware that the coupled (screw-in) portion of the piston rod could become loosened.

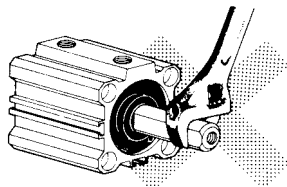

③ Using a non-rotating rod cylinder

- Avoid using the air cylinder in such a way that rotational torque would be applied to the piston rod. If rotational torque is applied, the non-rotating guide will be deformed, causing a loss of non-rotating accuracy. Use the chart below as a guide for the allowable rotational torque ranges.

Rotating torque. kgfcm or less	ø12	ø16	ø20	ø25	ø32	ø40	ø50	ø63
	0.4	1.5	2.0	2.5	4.5	4.5	4.5	4.5

- Operate the cylinder in such a way that the load to the piston rod is always applied in the axial direction.

Standard Specifications

Style	Pneumatic (Non-lube)
Fluid	Air
Proof pressure	1.5MPa
Max. operating pressure	1.0MPa
Ambient and fluid temperature	Without auto switch: -10°C to 70°C (No freezing)
	With auto switch: -10°C to 60°C (No freezing)
Rubber bumper	None ⁽³⁾
Rod end thread	Female thread
Rod end thread tolerance	JIS class 2
Stroke length tolerance	$\begin{matrix} +1.0 \\ 0 \end{matrix}$
Mounting	Through-hole
Piston speed	50 to 500mm/s

Note 3) ø12, with switch: Rubber bumper is standard.

Minimum Operating Pressure

Unit: MPa

Bore size (mm)	12	16	20	25	32	40	50	63
Min. operating press	0.07	0.07	0.05	0.05	0.05	0.05	0.05	0.05

Non-rotating Accuracy

Bore size (mm)	12	16	20	25	32	40	50	63
Non-rotating accuracy	±2°	±1°					±0.8°	

Allowable Kinetic Energy

Unit: J

Bore size (mm)	12	16	20	25	32	40	50	63	80	100
Standard	0.022	0.038	0.055	0.09	0.15	0.26	0.46	0.77	1.36	2.27

Standard Stroke

Unit: mm

Bore size	Standard stroke
12, 16	5, 10, 15, 20, 25, 30
20, 25, 32, 40	5, 10, 15, 20, 25, 30, 35, 40, 45, 50
50, 63	10, 15, 20, 25, 30, 35, 40, 45, 50

Theoretical Force

Unit: N

Bore size (mm)	Operating pressure (MPa)			Bore size (mm)	Operating pressure (MPa)		
	0.3	0.5	0.7		0.3	0.5	0.7
12	25	42	59	32	181	302	422
16	45	75	106	40	317	528	739
20	71	118	165	50	495	825	1150
25	113	189	264	63	841	1400	1960

Series CQ2KW

Weight

Unit: g

Bore size (mm)	Cylinder stroke (mm)									
	5	10	15	20	25	30	35	40	45	50
12	62	69	76	83	90	97	—	—	—	—
16	62	73	84	95	106	117	—	—	—	—
20	101	116	131	146	161	176	191	206	221	236
25	138	155	172	189	206	223	240	257	274	291
32	242	266	290	314	338	362	386	410	434	458
40	349	380	411	442	473	504	535	566	597	628
50	—	548	593	638	683	728	773	818	863	908
63	—	772	811	850	889	928	967	1006	1045	1084

Option Weights

Unit: g

Bore size (mm)	12	16	20	25	32	40	50	63
Both ends tapped	—	—	—	—	—	6	6	19
Rod end male thread	Male thread	3	6	12	24	52	54	106
	Nut	2	4	8	16	34	34	64
One-touch fitting	—	—	—	—	12	12	21	21
Foot	—	—	—	—	—	155	243	324
Flange	—	—	—	—	—	214	373	559

Calculation example: CQ2KWA40-20DM Basic weight: CQ2KWB40-20D.....442g
 Additional weight: Both ends tapped.....6g
 Rod end male thread.....88g
 536g

Construction

ø12 to ø32

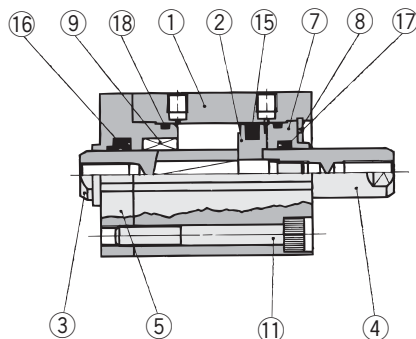

With fitting

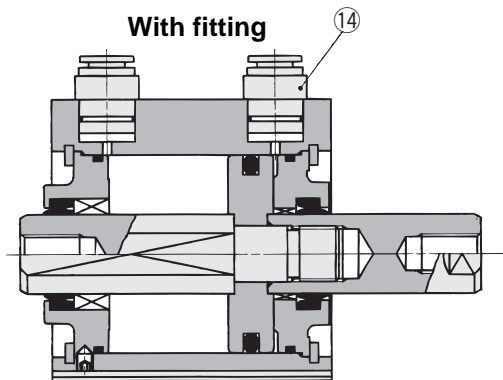

ø40 to ø63

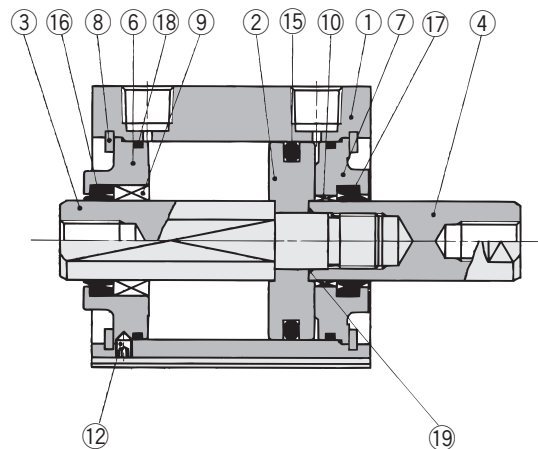

Rod end male thread

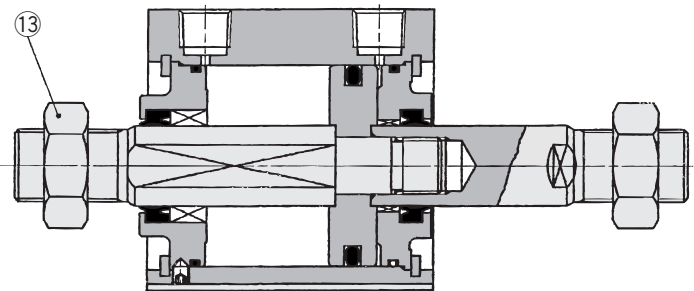

Component Parts

No.	Description	Material	Note
①	Cylinder tube	Aluminum alloy	Hard anodized
②	Piston	Aluminum alloy	Chromate
③	Piston A	Stainless steel	ø12 to ø25
		Carbon steel	ø32 to ø63, Hard chrome plated
④	Piston B	Stainless steel	ø12 to ø25
		Carbon steel	ø32 to ø63, Hard chrome plated
⑤	Rod cover	Brass	ø12, Nickel plated
		Aluminum alloy	ø16 to ø32, Anodized
⑥	Collar for non-rotating	Aluminum alloy	ø40 to ø63, Anodized
⑦	Collar	Aluminum bearing alloy	ø12 to ø40, Anodized
		Aluminum alloy casting	ø50 to ø63, Chromated, coated
⑧	Snap ring	Carbon tool steel	Phosphate coating
⑨	Bushing for non-rotating	Oil impregnated sintered alloy	ø16 to ø63
⑩	Bushing	Lead bronze casting	ø50, ø63
⑪	Hex. socket head cap screw	Alloy steel	ø12 to ø32, Nickel plated
⑫	Hex. socket set screw	Alloy steel	ø40 to ø63, Nickel plated
⑬	Rod end nut	Carbon steel	Nickel plated
⑭	One-touch fitting	—	ø32 to ø63

No.	Description	Material	Note
⑮	Piston seal	NBR	
⑯	Rod seal for non-rotating	NBR	
⑰	Rod seal	NBR	
⑱	Gasket	NBR	
⑲	Piston gasket	NBR	ø32 to ø63

Replacement Parts: Seal Kits

Bore size (mm)	Kit No.	Note
12	CQ2KWB12-PS	A set of above nos. ⑮, ⑯, ⑰ and ⑱.
16	CQ2KWB16-PS	
20	CQ2KWB20-PS	
25	CQ2KWB25-PS	
32	CQ2KWB32-PS	
40	CQ2KWB40-PS	
50	CQ2KWB50-PS	
63	CQ2KWB63-PS	

* Seal kits are sets consisting of items ⑮, ⑯, ⑰ and ⑱, which can be ordered using the order number for each cylinder bore size.

Compact Cylinder/Non-rotating Rod: Double Acting Double Rod Series **CQ2KW**

Mounting Bolt for CQ2KWB

Special bolt for through-hole mounting of CQ2KWB is available as option.

How to Order: Specify the required bolts

Example) Bolt M3 X 40 ℓ 2 pcs.

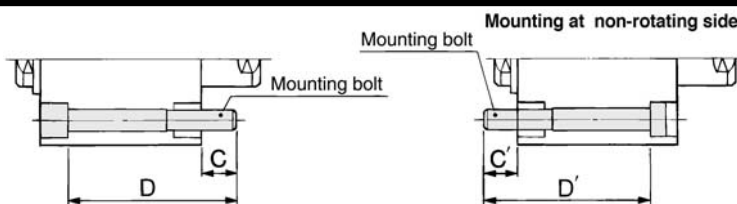

Model	C	D	Mounting bolt	C'	D'	Mounting bolt
CQ2KWB12-5D	8.3	40	M3 X 40 ℓ	8.3	40	M3 X 40 ℓ
-10D		45	X 45 ℓ		45	X 45 ℓ
-15D		50	X 50 ℓ		50	X 50 ℓ
-20D		55	X 55 ℓ		55	X 55 ℓ
-25D		60	X 60 ℓ		60	X 60 ℓ
-30D		65	X 65 ℓ		65	X 65 ℓ
CQ2KWB16-5D	7.5	40	M3 X 40 ℓ	7.5	40	M3 X 40 ℓ
-10D		45	X 45 ℓ		45	X 45 ℓ
-15D		50	X 50 ℓ		50	X 50 ℓ
-20D		55	X 55 ℓ		55	X 55 ℓ
-25D		60	X 60 ℓ		60	X 60 ℓ
-30D		65	X 65 ℓ		65	X 65 ℓ
CQ2KWB20-5D	6.5	40	M5 X 40 ℓ	8	40	M5 X 40 ℓ
-10D		45	X 45 ℓ		45	X 45 ℓ
-15D		50	X 50 ℓ		50	X 50 ℓ
-20D		55	X 55 ℓ		55	X 55 ℓ
-25D		60	X 60 ℓ		60	X 60 ℓ
-30D		65	X 65 ℓ		65	X 65 ℓ
-35D		70	X 70 ℓ		70	X 70 ℓ
-40D		75	X 75 ℓ		75	X 75 ℓ
-45D		80	X 80 ℓ		80	X 80 ℓ
-50D		85	X 85 ℓ		85	X 85 ℓ
CQ2KWB25-5D	8.5	45	M5 X 45 ℓ	10	45	M5 X 45 ℓ
-10D		50	X 50 ℓ		50	X 50 ℓ
-15D		55	X 55 ℓ		55	X 55 ℓ
-20D		60	X 60 ℓ		60	X 60 ℓ
-25D		65	X 65 ℓ		65	X 65 ℓ
-30D		70	X 70 ℓ		70	X 70 ℓ
-35D		75	X 75 ℓ		75	X 75 ℓ
-40D		80	X 80 ℓ		80	X 80 ℓ
-45D		85	X 85 ℓ		85	X 85 ℓ
-50D		90	X 90 ℓ		90	X 90 ℓ
CQ2KWB32-5D	11	50	M5 X 50 ℓ	7.5	45	M5 X 45 ℓ
-10D		55	X 55 ℓ		50	X 50 ℓ
-15D		60	X 60 ℓ		55	X 55 ℓ
-20D		65	X 65 ℓ		60	X 60 ℓ
-25D		70	X 70 ℓ		65	X 65 ℓ
-30D		75	X 75 ℓ		70	X 70 ℓ
-35D		80	X 80 ℓ		75	X 75 ℓ
-40D		85	X 85 ℓ		80	X 80 ℓ
-45D		90	X 90 ℓ		85	X 85 ℓ
-50D		95	X 95 ℓ		90	X 90 ℓ

Model	C	D	Mounting bolt
CQ2KWB40-5D	7	45	M5 X 45 ℓ
-10D		50	X 50 ℓ
-15D		55	X 55 ℓ
-20D		60	X 60 ℓ
-25D		65	X 65 ℓ
-30D		70	X 70 ℓ
-35D		75	X 75 ℓ
-40D		80	X 80 ℓ
-45D		85	X 85 ℓ
-50D		90	X 90 ℓ
CQ2KWB50-10D	12.5	55	M6 X 55 ℓ
-15D		60	X 60 ℓ
-20D		65	X 65 ℓ
-25D		70	X 70 ℓ
-30D		75	X 75 ℓ
-35D		80	X 80 ℓ
-40D		85	X 85 ℓ
-45D		90	X 90 ℓ
-50D		95	X 95 ℓ
CQ2KWB63-10D		13.5	55
-15D	60		X 60 ℓ
-20D	65		X 65 ℓ
-25D	70		X 70 ℓ
-30D	75		X 75 ℓ
-35D	80		X 80 ℓ
-40D	85		X 85 ℓ
-45D	90	X 90 ℓ	
-50D	95	X 95 ℓ	

- CUJ**
- CU**
- CQS**
- CQ2**
- RQ**
- MU**

Copper Free

20 — CQ2KWB Bore Size — Stroke D (M)
 Copper Free Series — **ø16, ø20, ø25, ø32, ø40, ø50, ø63**

To eliminate influences of copper ions or halogen ions during CRT manufacturing processes, copper and fluorine materials are not used as component parts.

Specifications

Action	Double acting double rod
Cylinder bore size	ø16, ø20, ø25, ø32, ø40, ø50, ø63
Proof Pressure	1.5MPa
Max. operating pressure	1.0MPa
Rubber bumper	None
Piping	Screw-in piping
Piston speed	50 to 500mm/s
Mounting	Through-hole
Auto switch	Mountable

Series CDQ2KW Auto Switch Specifications

* Refer to p.5.3-2 for details of auto switch.



Minimum Strokes for Auto Switch Mounting

(mm)

Number of auto switches	D-F7□V D-J79C D-F9□V	D-A7□ D-A80 D-A73C D-A80C D-A9□V D-A9□	D-F7□WV D-F9□WV	D-A7□H D-A80H D-F7□ D-J79 D-F9B D-F9P D-F9□W	D-A79W	D-F7□W D-J79W D-F7BAL D-F79F D-F9BAL	D-F7LF	D-F9N
	1	5	5	10	15	15	20	25
2	5	10	15	15	20	20	25	10

Weight

Unit: g

Bore size (mm)	Cylinder stroke (mm)									
	5	10	15	20	25	30	35	40	45	50
12	82	90	98	106	114	122	—	—	—	—
16	103	114	125	136	147	158	—	—	—	—
20	169	186	203	220	237	254	271	288	305	322
25	231	248	265	282	299	316	333	350	367	384
32	270	294	318	342	366	390	414	438	462	486
40	458	489	520	551	582	613	644	675	706	737
50	—	680	725	770	815	860	905	950	995	1040
63	—	906	945	984	1023	1062	1101	1140	1179	1218

Option Weights

Unit: g

Bore size (mm)	12	16	20	25	32	40	50	63
Both ends tapped	—	—	—	—	—	6	6	19
Rod end male thread	Male thread	3	6	12	24	52	54	106
	Nut	2	4	8	16	34	34	64
With fitting	—	—	—	—	12	12	21	21

Calculation example: CDQ2KWA40-20DM

- Basic weight: CDQ2KWB40-20D 551g
- Additional weight: Both ends tapped 6g
- Rod end male thread 88g

Add each weight of auto switches and mounting brackets when auto switches are required.

645g

Weight/Auto Switch Mounting Bracket

Part No.	Bore size	Weight (g)
BQ-1	ø12 to ø25	1.5
BQ-2	ø32 to ø63	1.5

* Refer to p.5.3-75 for auto switch weight.

Construction

ø12 to ø25

ø32

ø40 to ø63

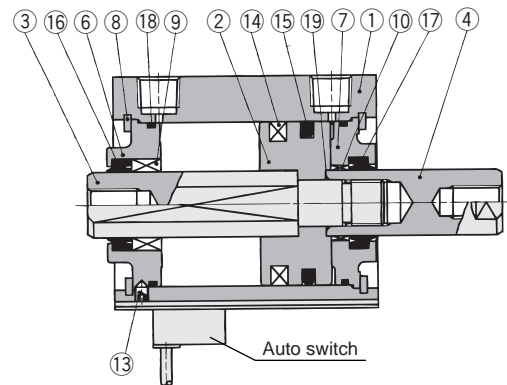
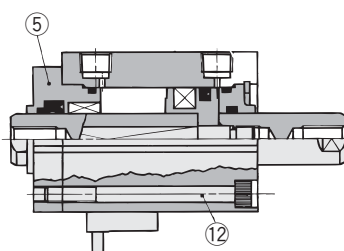
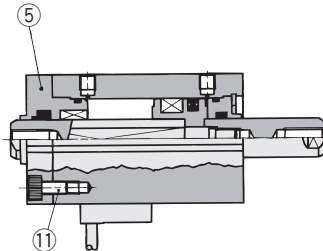

Component Parts

NO.	Description	Material	Note
①	Cylinder tube	Aluminum alloy	Hard anodized
②	Piston	Aluminum alloy	Chromated
③	Piston rod A	Stainless steel	ø12 to ø25
		Carbon steel	ø32 to ø63, Hard chrome plated
④	Piston rod B	Stainless steel	ø12 to ø25
		Carbon steel	ø32 to ø63, Hard chrome plated
⑤	Rod cover	Brass	ø12, Nickel plated
		Aluminum alloy	ø16 to ø32, Anodized
⑥	Collar for non-rotating	Aluminum alloy	ø40 to ø63, Anodized
⑦	Collar	Aluminum bearing alloy	ø12 to ø40, Anodized
		Aluminum alloy casting	ø50 to ø63, Chromated, coated
⑧	Snap ring	Carbon tool steel	Phosphate coating
⑨	Bushing for non-rotating	Oil impregnated sintered alloy	ø16 to ø63
⑩	Bushing	Lead bronze casting	ø50, ø63
⑪	Hex. socket head cap screw	Alloy steel	ø12 to ø25, Nickel plated
⑫	Hex. socket head cap screw	Alloy steel	ø32, Nickel plated
⑬	Hex. socket set screw	Alloy steel	ø40 to ø63, Nickel plated
⑭	Magnet	—	—

NO.	Description	Material	Note
⑮	Piston seal	NBR	
⑯	Rod seal for non-rotating	NBR	
⑰	Rod seal	NBR	
⑱	Gasket	NBR	
⑲	Piston gasket	NBR	ø32 to ø63

Replacement Parts: Seal Kits

Bore size (mm)	Kit No.	Note
12	CQ2KWB12-PS	A set of above nos. ⑮, ⑯, ⑰ and ⑱.
16	CQ2KWB16-PS	
20	CQ2KWB20-PS	
25	CQ2KWB25-PS	
32	CQ2KWB32-PS	
40	CQ2KWB40-PS	
50	CQ2KWB50-PS	
63	CQ2KWB63-PS	

* Seal kits are sets consisting of items ⑮, ⑯, ⑰ and ⑱, which can be ordered using the order number for each cylinder bore size.

Compact Cylinder/Non-rotating Rod: Double Acting Double Rod Series **CDQ2KW**

Mounting Bolt for CDQ2KWB with Auto Switch

Special bolt for through-hole mounting of CDQ2KWB is available as option.

How to Order: Specify the required bolts.
Ex.) Bolt M3 X 40 ℓ 2 pcs.

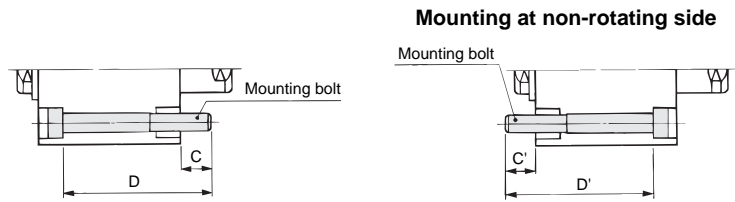

Model	C	D	Mounting bolt	C'	D'	Mounting bolt
CDQ2KWB12-5DC	6.1	40	M3 X 40 ℓ	6.1	45	M3 X 45 ℓ
-10DC		45	X 45 ℓ		50	X 50 ℓ
-15DC		50	X 50 ℓ		55	X 55 ℓ
-20DC		55	X 55 ℓ		60	X 60 ℓ
-25DC		60	X 60 ℓ		65	X 65 ℓ
-30DC	65	X 65 ℓ	70	X 70 ℓ		
CDQ2KWB16-5D	7.5	45	M3 X 45 ℓ	7.5	50	M3 X 50 ℓ
-10D		50	X 50 ℓ		55	X 55 ℓ
-15D		55	X 55 ℓ		60	X 60 ℓ
-20D		60	X 60 ℓ		65	X 65 ℓ
-25D		65	X 65 ℓ		70	X 70 ℓ
-30D	70	X 70 ℓ	75	X 75 ℓ		
CDQ2KWB20-5D	9	45	M5 X 45 ℓ	11	55	M5 X 55 ℓ
-10D		50	X 50 ℓ		60	X 60 ℓ
-15D		55	X 55 ℓ		65	X 65 ℓ
-20D		60	X 60 ℓ		70	X 70 ℓ
-25D		65	X 65 ℓ		75	X 75 ℓ
-30D	70	X 70 ℓ	80	X 80 ℓ		
-35D	75	X 75 ℓ	85	X 85 ℓ		
-40D	80	X 80 ℓ	90	X 90 ℓ		
-45D	85	X 85 ℓ	95	X 95 ℓ		
-50D	90	X 90 ℓ	100	X 100 ℓ		
CDQ2KWB25-5D	8	45	M5 X 45 ℓ	10	55	M5 X 55 ℓ
-10D		50	X 50 ℓ		60	X 60 ℓ
-15D		55	X 55 ℓ		65	X 65 ℓ
-20D		60	X 60 ℓ		70	X 70 ℓ
-25D		65	X 65 ℓ		75	X 75 ℓ
-30D	70	X 70 ℓ	80	X 80 ℓ		
-35D	75	X 75 ℓ	85	X 85 ℓ		
-40D	80	X 80 ℓ	90	X 90 ℓ		
-45D	85	X 85 ℓ	95	X 95 ℓ		
-50D	90	X 90 ℓ	100	X 100 ℓ		
CDQ2KWB32-5D	11	60	M5 X 60 ℓ	7.5	55	M5 X 55 ℓ
-10D		65	X 65 ℓ		60	X 60 ℓ
-15D		70	X 70 ℓ		65	X 65 ℓ
-20D		75	X 75 ℓ		70	X 70 ℓ
-25D		80	X 80 ℓ		75	X 75 ℓ
-30D	85	X 85 ℓ	80	X 80 ℓ		
-35D	90	X 90 ℓ	85	X 85 ℓ		
-40D	95	X 95 ℓ	90	X 90 ℓ		
-45D	100	X 100 ℓ	95	X 95 ℓ		
-50D	105	X 105 ℓ	100	X 100 ℓ		

Model	C	D	Mounting bolt
CDQ2KWB40-5D	7	55	M5 X 55 ℓ
-10D		60	X 60 ℓ
-15D		65	X 65 ℓ
-20D		70	X 70 ℓ
-25D		75	X 75 ℓ
-30D	80	X 80 ℓ	
-35D	85	X 85 ℓ	
-40D	90	X 90 ℓ	
-45D	95	X 95 ℓ	
-50D	100	X 100 ℓ	
CDQ2KWB50-10D	12.5	65	M6 X 65 ℓ
-15D		70	X 70 ℓ
-20D		75	X 75 ℓ
-25D		80	X 80 ℓ
-30D		85	X 85 ℓ
-35D	90	X 90 ℓ	
-40D	95	X 95 ℓ	
-45D	100	X 100 ℓ	
-50D	105	X 105 ℓ	
CDQ2KWB63-10D	13.5	65	M8 X 65 ℓ
-15D		70	X 70 ℓ
-20D		75	X 75 ℓ
-25D		80	X 80 ℓ
-30D		85	X 85 ℓ
-35D	90	X 90 ℓ	
-40D	95	X 95 ℓ	
-45D	100	X 100 ℓ	
-50D	105	X 105 ℓ	

CUJ

CU

CQS

CQ2

RQ

MU

Auto Switch Mounting Bracket Part No.

Bore size (mm)	Part No.	Note	Applicable switch	
			Reed switch	Solid state switch
12/16 20/25	BQ-1	<ul style="list-style-type: none"> Switch mounting screw (M3 X 0.5 X 8 ℓ) Square nut 	D-A7□, A80 D-A73C, A80C D-A7□H, A80H D-A79W	D-F7□, J79 D-F7□V D-J79C D-F7□W, J79W D-F7□WV D-F7BAL D-F7□F D-F7NTL
32/40 50/63	BQ-2	<ul style="list-style-type: none"> Switch mounting screw (M3 X 0.5 X 10 ℓ) Switch spacer Switch mounting nut 		



* Mounting screw set made by stainless steel

Following stainless steel mounting screw set (including nut) is provided. Use them in accordance with environment. (Auto switch interface is not included. Order it separately.)

BBA2: For D-A7/A8/F7/J7

When D-F7BAL mounted on cylinder is required, the stainless steel screw mentioned above is used at shipping. When auto switch unit is shipped, BBA2 is attached.

Series CDQ2KW

Auto Switch Mounting Position (at Stroke End) and Mounting Height

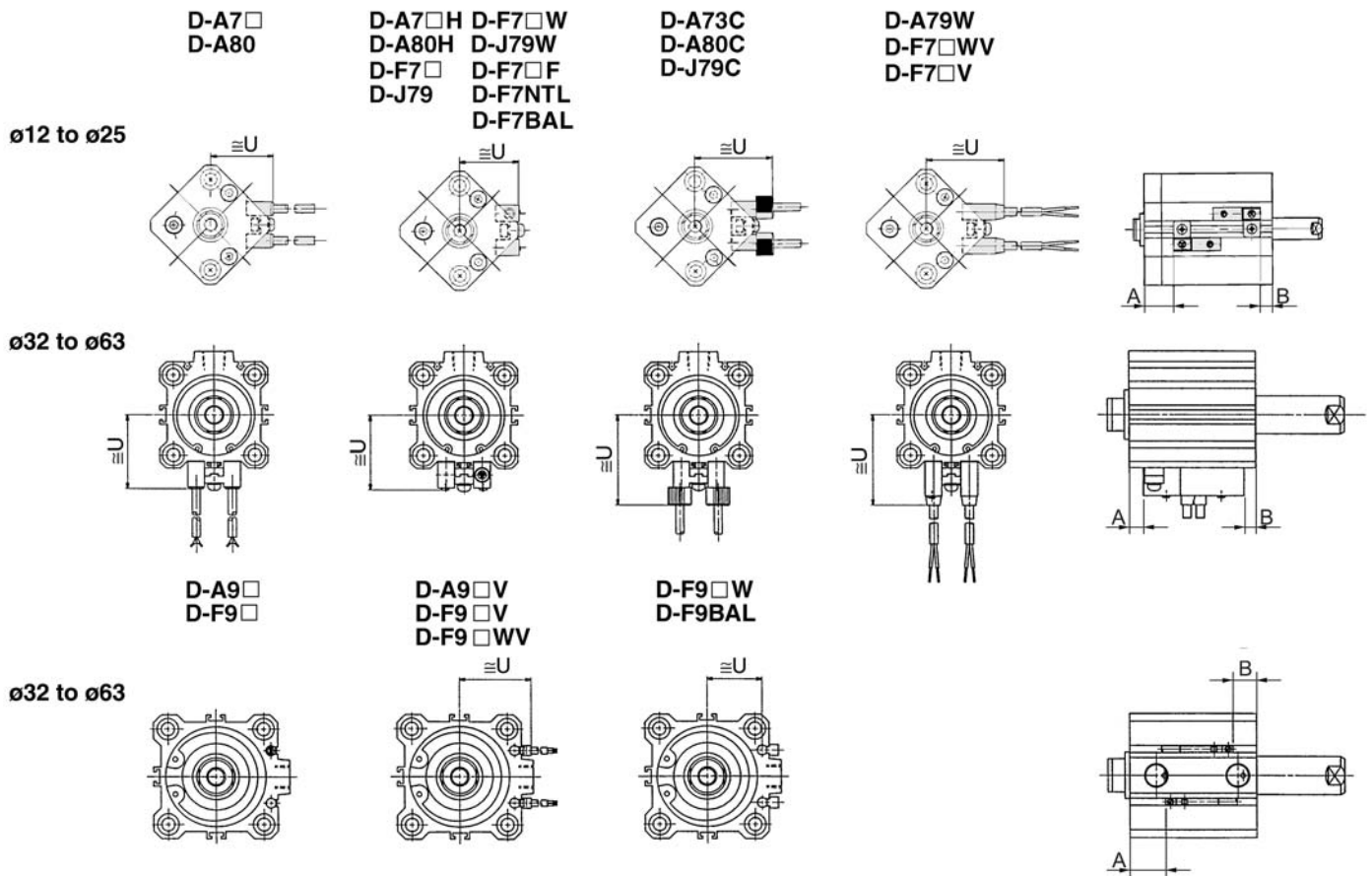

Auto Switch Mounting Position

Bore size (mm)	D-A7□ D-A80		D-A7□H/A80H D-A73C/A80C D-F7□/J79 D-F7□V/J79C		D-A79W		D-F7BAL D-F7□W D-F7□F D-J79W D-F7□WV		D-A9□ D-A9□V		D-F9□ D-F9□V		D-F9□W D-F9□WV D-F9BAL	
	A	B	A	B	A	B	A	B	A	B	A	B	A	B
12	9.5	10	10	10.5	7	7.5	14	14.5	-	-	-	-	-	-
16	12.5	10.5	13	11	10	8	17	15	-	-	-	-	-	-
20	15.5	13	16	13.5	13	10.5	20	17.5	-	-	-	-	-	-
25	15.5	13	16	13.5	13	10.5	20	17.5	-	-	-	-	-	-
32	18	13.5	18.5	14	15.5	11	22.5	18	17	12.5	21	16.5	20	15.5
40	13	19	13.5	19.5	10.5	16.5	17.5	23.5	12	18	16	22	15	21
50	11	21.5	11.5	22	8.5	19	15.5	26	10	20.5	14	24.5	13	23.5
63	13.5	20.5	14	21	11	18	18	25	12.5	19.5	16.5	23.5	15.5	22.5

Auto Switch Mounting Height

(mm)

D-A7□ D-A80	D-A7□H D-A80H D-F7□ D-J79 D-F7□W D-F79W D-F7BAL D-F7□F D-F7NTL	D-A73C D-A80C	D-F7□V D-F7□WV	D-J79C	D-A79W	D-A9□V	D-F9□V D-F9□WV	D-F9□W D-F9BAL
U	U	U	U	U	U	U	U	U
19.5	20.5	26.5	23	26	22	-	-	-
22.5	23.5	29.5	26	29	25	-	-	-
24.5	25.5	31.5	28	31	27	-	-	-
27.5	28.5	34.5	31	34	30	-	-	-
31.5	32.5	38.5	35	38	34	27	29	26.5
35	36	42	38.5	41.5	37.5	30.5	32.5	30
41	42	48	44.5	47.5	43.5	36.5	38.5	36
47.5	48.5	54.5	51	54	50	40	42	39.5

CUJ

CU

CQS

CQ2

RQ

MU

Series CQ2KW

ø12 to ø32 Without Auto Switch

ø12, ø16

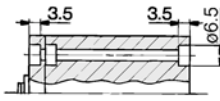

ø20, ø25

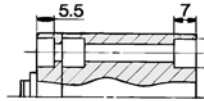

Standard (Through-hole) /CQ2KWB

ø12 to ø25

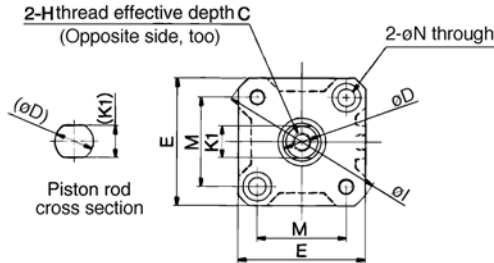
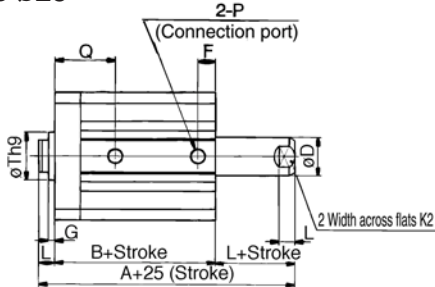

ø32

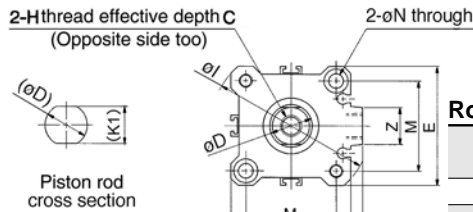
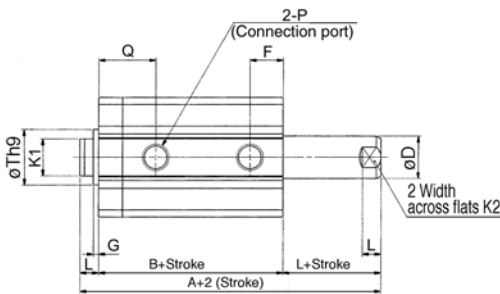
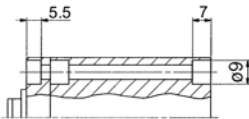

Rod end male thread (mm)

Bore (mm)	A ₁	C ₁	H ₁
12	58.2	9	M5 X 0.8
16	62	10	M6 X 1.0
20	71	12	M8 X 1.25
25	82	15	M10 X 1.25
32	96.5	20.5	M14 X 1.5

Bore (mm)	L ₁	X
12	14	10.5
16	15.5	12
20	18.5	14
25	22.5	17.5
32	28.5	23.5

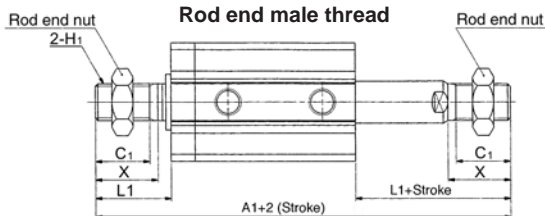

With built-in One-touch Fitting/ø32

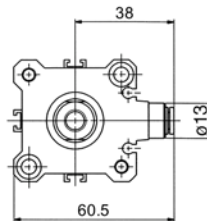
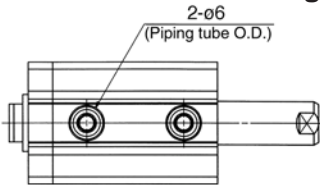

* Dimensions of ø32, 5 stroke with built-in One-touch fitting are same as 10 stroke. (mm)

Standard

Bore (mm)	Stroke range (mm)	A	B	C	D	E	F	G	H	I	J	K1	K2	L	M	N	P	Q	Th9	W	Z
12	5 to 30	37.2	30.2	6	6	25	10	1.5	M3 X 0.5	32	-	5.2	5	3.5	15.5	3.5	M5 X 0.8	15	15 ⁰ _{-0.043}	-	-
16	5 to 30	38	31	8	8	29	10	1.5	M4 X 0.7	38	-	6	6	3.5	20	3.5	M5 X 0.8	15	20 ⁰ _{-0.052}	-	-
20	5 to 50	43	34	7	10	36	9.5	2	M5 X 0.8	47	-	8	8	4.5	25.5	5.5	M5 X 0.8	17.5	13 ⁰ _{-0.043}	-	-
25	5 to 50	47	37	12	12	40	11	2	M6 X 1.0	52	-	10	10	5	28	5.5	M5 X 0.8	19	15 ⁰ _{-0.043}	-	-
32	5	53.5	39.5	13	16	45	12.5	2	M8 X 1.25	60	4.5	14	14	7	34	5.5	M5 X 0.8	21.5	21 ⁰ _{-0.052}	49.5	14
	1/8																				

* Refer to p.2.3-18 & 19 for details rod end nut and optional bracket.

Compact Cylinder/Non-rotating Rod: Double Acting Double Rod **Series CDQ2KW**

ø12 to ø32 With Auto Switch

Standard (Through-hole)/CDQ2KWB

ø12 to ø25

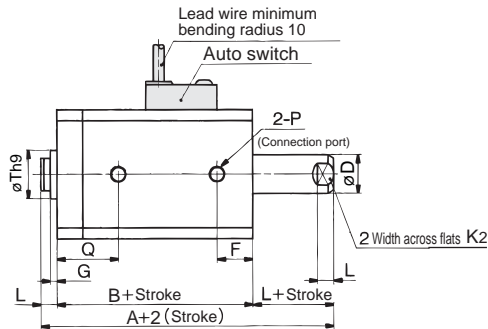
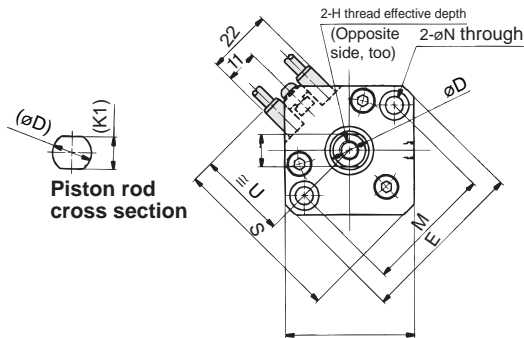
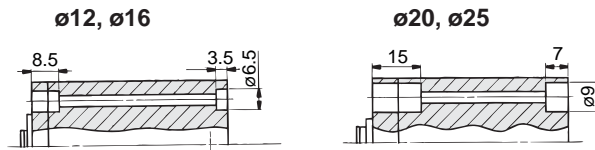

ø32

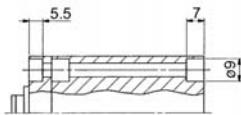

ø32

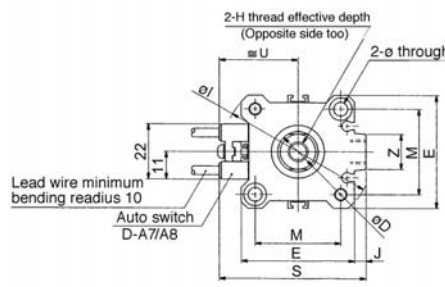
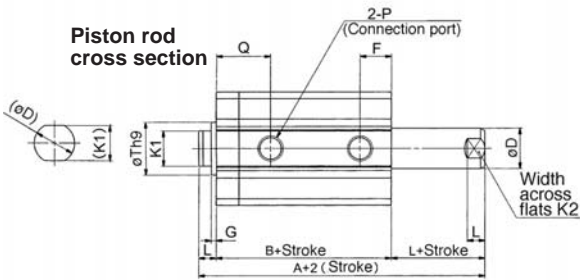

Rod end male thread

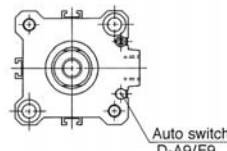
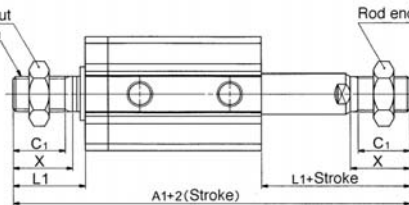

Rod end male thread (mm)

Bore (mm)	A1	C1	H1
12	65.4	9	M5 X 0.8
16	72	10	M6 X 1.0
20	83	12	M8 X 1.25
25	92	15	M10 X 1.25
32	106.5	20.5	M14 X 1.5

Bore (mm)	L1	X
12	14	10.5
16	15.5	12
20	18.5	14
25	22.5	17.5
32	28.5	23.5

CUJ

CU

CQS

CCQ2

RQ

MU

With built-in One-touch fitting/ø32



Above auto switch: D-A73/A80.
Refer to p.2.3-76 for auto switch mounting position and mounting height.

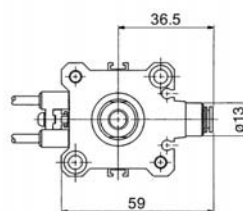
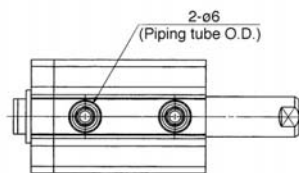

Standard

Bore (mm)	Stroke range (mm)	A	B	C	D	E	F	G	H	I	J	K1	K2	L	M	N	p	Q	S	Th9	U	V	Z
12	5 to 30	44.4	37.4	6	6	32	10.5	1.5	M3 X 0.5	—	—	5.2	5	3.5	22	3.5	M5 X 0.8	15.5	35.5	15 ⁰ _{-0.052}	19.5	25	—
16	5 to 30	48	41	8	8	38	10	1.5	M4 X 0.7	—	—	6	6	3.5	28	3.5	M5 X 0.8	15	41.5	20 ⁰ _{-0.052}	22.5	29	—
20	5 to 50	55	46	7	10	47	10.5	2	M5 X 0.8	—	—	8	8	4.5	36	5.5	M5 X 0.8	18.5	48	13 ⁰ _{-0.052}	24.5	36	—
25	5 to 50	57	47	12	12	52	11	2	M6 X 1.0	—	—	10	10	5	40	5.5	M5 X 0.8	19	53.5	15 ⁰ _{-0.052}	27.5	40	—
32	5 to 50	63.5	49.5	13	16	45	12.5	2	M8 X 1.25	60	4.5	14	14	7	34	5.5	1/8	21.5	58.5	21 ⁰ _{-0.052}	31.5	—	14

*Refer to p.2.3-18 & 19 for details of rod end nut and optional bracket.

Series CQ2KW/CDQ2KW

ø40 to ø63 With Auto Switch

(For those without auto switches, refer to dimensions label because A and B dimensions vary.)

Standard (Through-hole)/CQ2KWB, CDQ2KWB

Both ends tapped: CQ2KWA/CDQ2KWA

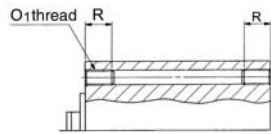

Both ends tapped (mm)

Bore (mm)	O1	R
40	M6 X 1.0	10
50	M8 X 1.25	14
63	M10 X 1.5	18

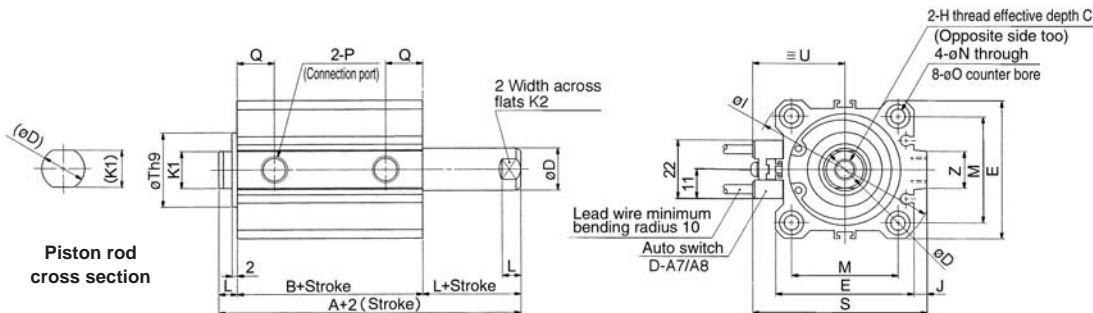

Rod end male thread

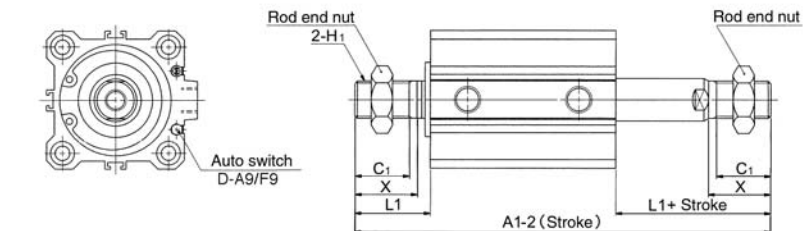

Rod end male thread (mm)

Bore (mm)	One-touch fitting	Without auto switch	C ₁	H ₁	L ₁	X
	A ₁	A ₁				
40	97	107	20.5	M14 X 1.5	28.5	23.5
50	107.5	117.5	26	M18 X 1.5	33.5	28.5
63	109	119	26	M18 X 1.5	33.5	28.5

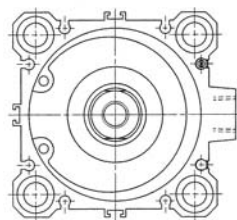

ø63 Cylinder tube form

With built-in One-touch fitting

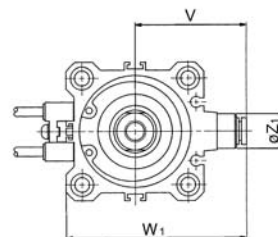
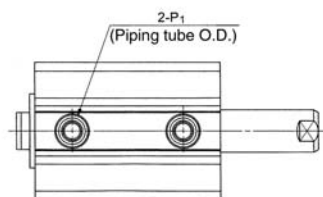

With built-in One-touch fitting (mm)

Bore (mm)	Z ₁	P ₁	V	W ₁
40	13	6	40.5	66.5
50	16	8	50	82
63	16	8	56.5	95



Above auto switch: D-A73/A80.
Refer to p.2.3-76 for auto switch mounting position and mounting height.

Standard

Bore (mm)	Stroke range (mm)	W/o auto switch		W/ auto switch		C	D	E	H	I	J	K1	K2	L	M	N	O	P	Q	S	Th9	U	Z	
		A	B	A	B																			
40	5 to 50	54	40	64	50	13	16	52	M8 X 1.25	69	5	14	14	7	40	5.5	9	Depth 7	1/8	14	66	28 ⁰ _{-0.052}	35	14
50	10 to 50	56.5	40.5	66.5	50.5	15	20	64	M10 X 1.5	86	7	18	17	8	50	6.6	11	Depth 8	1/4	14	80	35 ⁰ _{-0.062}	41	19
63	10 to 50	58	42	68	52	15	20	77	M10 X 1.5	103	7	18	17	8	60	9	14	Depth 10.5	1/4	15.5	93	35 ⁰ _{-0.062}	47.5	19



* Refer to p.2.3-18 & 19 for details of rod end nut and optional bracket.

Compact Cylinder/Non-rotating Rod: Double Acting Double Rod *Series CDQ2KW*

ø40 to ø63

Foot/CQ2KWL, CDQ2KWL

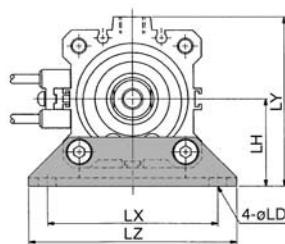
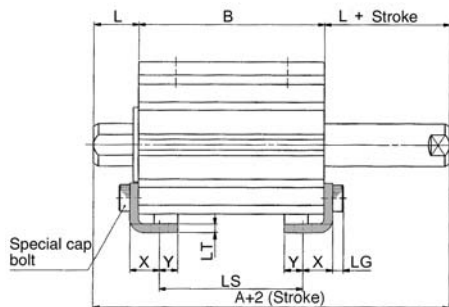
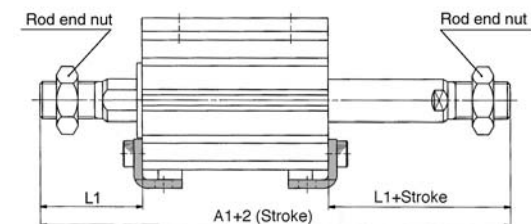

Rod end male thread (mm)

Bore (mm)	Without auto switch A1	With auto switch A1	L1
40	117	127	38.5
50	127.5	137.5	43.5
63	129	139	43.5

Foot (mm)

Bore (mm)	Stroke range (mm)	Without auto switch			With auto switch			L	LD	LG	LH	LT	LX	LY	LZ	X	Y
		A	B	LS	A	B	LS										
40	5 to 50	74	40	24	84	50	34	17	6.6	4	33	3.2	64	68	78	11.2	7
50	10 to 50	76.5	40.5	17.5	86.5	50.5	27.5	18	9	5	39	3.2	79	78	95	14.7	8
63	10 to 50	78	42	16	88	52	26	18	11	5	46	3.2	95	91.5	113	16.2	8

Flange/CQ2KWF, CDQ2KWL

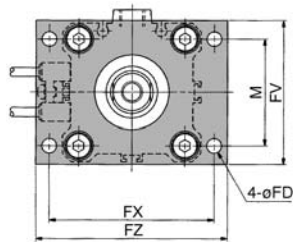
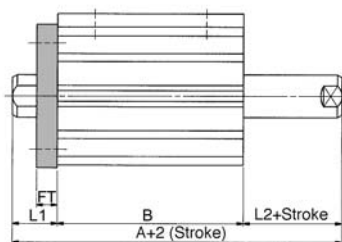
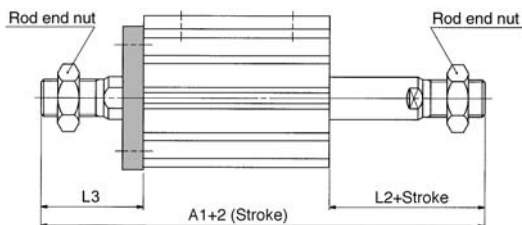

Rod end male thread (mm)

Bore (mm)	Without auto switch	With auto switch	L3	L4
	A1	A1		
40	107	117	38.5	28.5
50	117.5	127.5	43.5	33.5
63	119	129	43.5	33.5

Above auto switch: D-A73/A80

Refer to p.2.3-76 for auto switch mounting position and mounting height.

Flange (mm)

Bore (mm)	Stroke range (mm)	Without auto switch		With auto switch		FD	FT	FV	FX	FZ	L1	L2	M
		A	B	A	B								
40	5 to 50	64	40	74	50	5.5	8	54	62	72	17	7	40
50	10 to 50	66.5	40.5	76.5	50.5	6.6	9	67	76	89	18	8	50
63	10 to 50	68	42	78	52	9	9	80	92	108	18	8	60



* Refer to p.2.3-18 & 19 for rod end nut and optional bracket.

Compact Cylinder/Axial Piping: Double Acting Single Rod

Series CQP2

ø12, ø16, ø20, ø25, ø32, ø40, ø50, ø63, ø80, ø100

How to Order

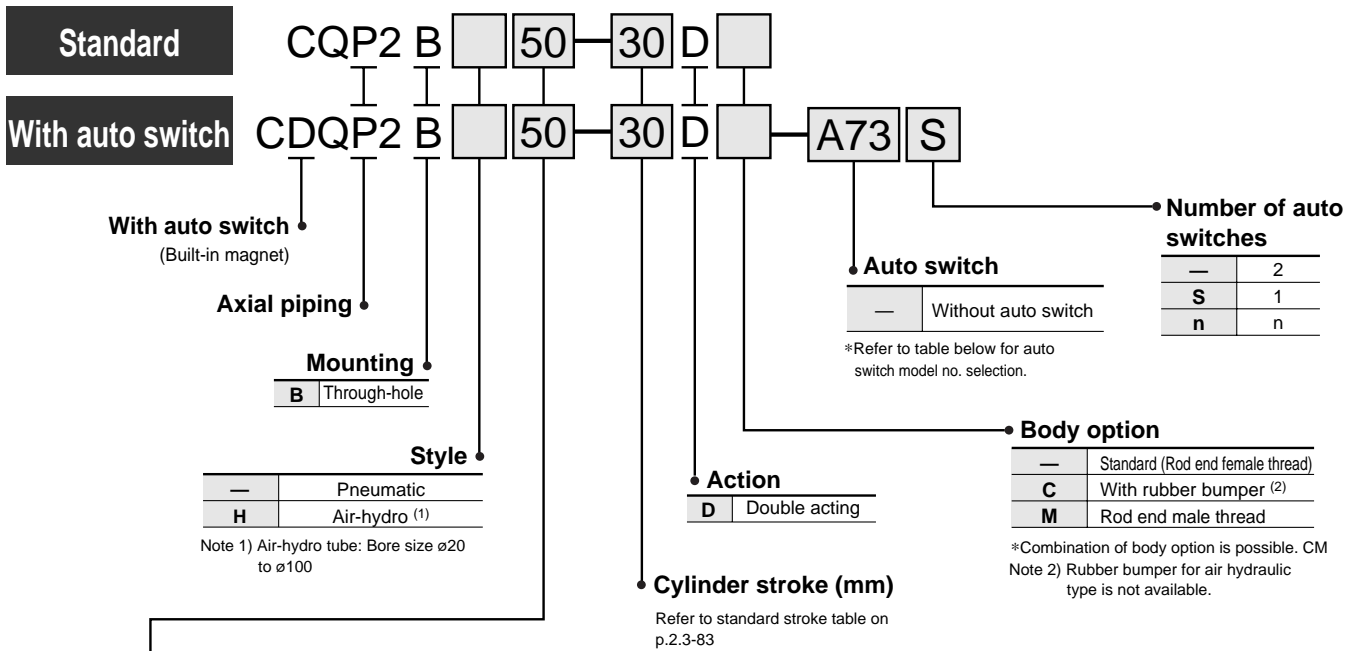

Bore size

12	12mm
16	16mm
20	20mm
25	25mm
32	32mm
40	40mm
50	50mm
63	63mm
80	80mm
100	100mm

Applicable Auto Switches/Refer to p.5.3-2 for further information on auto switch.

Style	Special function	Electrical entry	Indicator	Wiring (output)	Load voltage		Auto switch model		Lead wire* (m)				Applicable load																																					
					DC	AC	Perpendicular	In-line	0.5 (-)	3 (L)	5 (Z)	None (N)																																						
Reed switch	—	Grommet	Yes	3 wire (Equiv. NPN)	—	5V	—	A76H	●	●	—	—	IC	—																																				
									24V	12V	100V	A72			A72H	●	●	—	—																															
												A73			A73H	●	●	●	—																															
												A80			A80H	●	●	—	—																															
												A73C			—	●	●	●	●																															
												A80C			—	●	●	●	●																															
A79W	—	●	●	—	—																																													
Solid state switch	—	Grommet	Yes	3 wire (NPN)	5V, 12V	—	F7NV	F79	●	●	○	—	IC	Relay, PLC																																				
									3 wire (PNP)	F7PV	F7P	●			●	○	—																																	
									Connector	24V	12V	—			F7BV	J79	●	●	○	—																														
															J79C	—	●	●	●	●																														
															F7N WV	F79W	●	●	○	—																														
															—	F7PW	●	●	○	—																														
		F7B WV	J79W	●	●	○	—																																											
		—	F7BA	—	●	○	—																																											
		Diagnostic (2 colour)	Grommet	No	2 wire	5V, 12V	—	—	—	—	●	●	○	—	IC	Relay, PLC																																		
											Water resistant (2 colour)	Grommet	No	3 wire (NPN)			5V, 12V	—	—	—	—	●	●	○	—																									
																						With timer	Grommet	No	3 wire (PNP)	5V, 12V	—	—	—	—	●	●	○	—																
																															Diagnostic output (2 colour)	Grommet	No	2 wire	5V, 12V	—	—	—	—	●	●	○	—							
Latch type with diagnostic output (2 colour)	Grommet																																							No	4 wire (NPN)	—	—	—	—	—	●	●	○	—

*Lead wire length 0.5m — (Example) A80C 5m Z (Example) A80CZ
3m L (Example) A80CL None N (Example) A80CN

*Solid state switches marked with a "O" are manufactured upon receipt of order.

Compact Cylinder/Axial Piping: Double Acting Single Rod *Series CQP2*

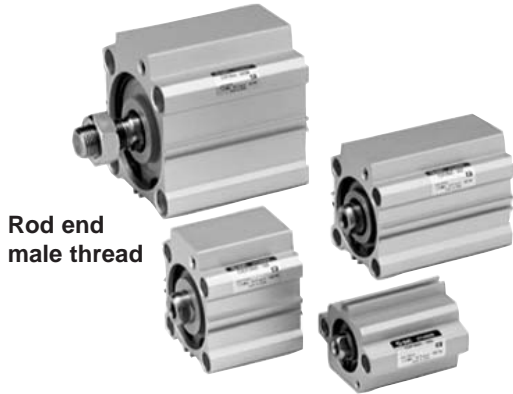

Rod end male thread

JIS symbol

Double acting: Single rod

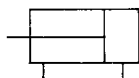

⚠ Precautions

Be sure to read before handling. Refer to p.0-39 to 0-46 for Safety Instructions, precautions on the products mentioned in this catalog and common precautions.

⚠ Caution

Snap Ring Installation/Removal

- For installation and removal, use an appropriate pair of pliers (tool for installing a C snap ring).
- Exercise caution even when using an appropriate pair of pliers (tool for installing a C snap ring), because of the possibility of the snap ring becoming detached from the tip of the pliers (tool for installing a C snap ring) and flying away, which could injure humans or damage the peripheral equipment. After installing the snap ring, make sure that it is placed securely in the ring groove before supplying air.

Mounting/Removing

- Do not remove the hexagon socket set screw on the side of the rod.
- Be aware that if the hexagon socket set screw is removed with compressed air supplied to the cylinder, an internal steel ball could fly out or the compressed air could be discharged, leading to injury to humans or damage to peripheral equipment.

Auto Switch Mounting Bracket Part No.

Bore size (mm)	Part No.	Note	Applicable switch	
			Reed switch	Solid state switch
12/16 20/25	BQ-1	<ul style="list-style-type: none"> Switch mounting screw (M3 X 0.5 X 8 ℓ) Square nut 	D-A7□, A80 D-A73C, A80C D-A7□H, A80H D-A79W	D-F7□, J79 D-F7□V, D-J79C D-F7□W, J79W D-F7□WV, D-F7BAL D-F7□F, D-F7NTL
32/40 50/63 80/100	BQ-2	<ul style="list-style-type: none"> Switch mounting screw (M3 X 0.5 X 10 ℓ) Switch mounting screw Switch mounting nut 		



*Stainless steel mounting bolt set
The set of stainless steel mounting screws (with nut) described below is available and can be used depending on the operating environment. (The spacer for auto switches must be ordered separately, as they are not included.)
BBA2: For D-A7/A8/F7/J7
The stainless steel bolts described above are used when the D-F7BAL type switch is shipped mounted on a cylinder. When the switches are shipped as individual parts, the BBA2 set is included.

Model

Bore size (mm)		12	16	20	25	32	40	50	63	80	100
Pneumatic	Mounting Through-hole (Std.)	●	●	●	●	●	●	●	●	●	●
	Built-in magnet	●	●	●	●	●	●	●	●	●	●
	Piping Screw-in style	M5 X 0.8	M5 X 0.8	M5 X 0.8	M5 X 0.8	Rc(PT) 1/8	Rc(PT) 1/8	Rc(PT) 1/4	Rc(PT) 1/4	Rc(PT) 3/8	Rc(PT) 3/8
	Rod end male thread	●	●	●	●	●	●	●	●	●	●
	Rubber bumper	●	●	●	●	●	●	●	●	●	●
Air-hydro	Mounting Through-hole (Std.)	—	—	●	●	●	●	●	●	●	●
	Built-in magnet	—	—	●	●	●	●	●	●	●	●
	Piping Screw-in style	—	—	M5 X 0.8	M5 X 0.8	Rc(PT) 1/8	Rc(PT) 1/8	Rc(PT) 1/4	Rc(PT) 1/4	Rc(PT) 3/8	Rc(PT) 3/8
	Rod end male thread	—	—	●	●	●	●	●	●	●	●

Standard Specifications

Style	Pneumatic (Non-lube)	Air-hydro
Fluid	Air	Turbine oil ⁽¹⁾
Proof pressure	1.5MPa	
Max. operating pressure	1.0MPa	
Ambient and fluid temperature	Without auto switch: -10°C to 70°C (No freezing) With auto switch: -10°C to 60°C (No freezing)	
Rubber bumper	None	—
Rod end thread	Female thread	
Rod end thread tolerance	JIS class 2	
Stroke length tolerance	+1.0	
Mounting	Through-hole	
Piston speed	50 to 500mm/s	5 to 50mm/s

Minimum Operating Pressure

Unit: MPa

Bore size (mm)	12	16	20	25	32	40	50	63	80	100
Pneumatic (non-lube)	0.07	0.07	0.05	0.05	0.05	0.05	0.05	0.05	0.05	0.05
Air-hydro	—	—	0.18	0.18	0.18	0.10	0.10	0.10	0.10	0.10

Allowable Kinetic Energy

Unit: J

Bore size (mm)	12	16	20	25	32	40	50	63	80	100
Standard type	0.022	0.038	0.055	0.09	0.15	0.26	0.46	0.77	1.36	2.27
With rubber bumper	0.043	0.075	0.11	0.18	0.29	0.52	0.91	1.54	2.71	4.54

Standard Stroke

Pneumatic (Non-lube) Unit: mm

Bore size	Standard stroke
12, 16	5, 10, 15, 20, 25, 30
20, 25	5, 10, 15, 20, 25, 30, 35, 40, 45, 50
32, 40	5, 10, 15, 20, 25, 30, 35, 40, 45, 50, 75, 100
50, 63 80, 100	10, 15, 20, 25, 30, 35, 40, 45, 50, 75, 100

Air-hydro Unit: mm

Bore size	Standard stroke
20, 25	5, 10, 15, 20, 25, 30, 35, 40, 45, 50
32, 40	5, 10, 15, 20, 25, 30, 35, 40, 45, 50, 75, 100
50, 63 80, 100	10, 15, 20, 25, 30, 35, 40, 45, 50, 75, 100



Refer to p.2.3-3 for intermediate stroke (except air hydraulic type)

Series CDQP2 Auto Switch Specifications

* Refer to p.5.3-2 for details of auto switch.



Weight

Unit: g

Bore (mm)	Cylinder stroke (mm)											
	5	10	15	20	25	30	35	40	45	50	75	100
12	54	62	69	75	82	89	—	—	—	—	—	—
16	91	99	107	115	123	131	—	—	—	—	—	—
20	121	135	147	161	175	188	201	214	228	242	—	—
25	177	190	203	217	230	244	257	270	284	297	—	679
32	217	242	266	290	315	339	363	387	412	436	557	814
40	319	345	371	397	423	449	475	502	528	554	684	1291
50	—	546	588	629	670	712	753	794	836	877	1084	1622
63	—	764	812	859	907	955	1002	1050	1098	1145	1384	2790
80	—	1377	1455	1534	1612	1691	1769	1848	1926	2005	2397	4060
100	—	2296	2394	2492	2590	2688	2786	2884	2982	3080	3570	—

Calculation example: CDQP2B32-20DCM
 •Basic weight: CDQP2B32-20D... 290g
 •Additional weight: Rod end male thread... 43g
 With rubber bumper... -3g
 330g

Add each weight of auto switches and mounting brackets.

Weight/Auto Switch Mounting Bracket

Mounting bracket	Bore size	Weight (g)
BQ-1	ø12 to ø25	1.5
BQ-2	ø32 to ø100	1.5

Refer to p.5.3-75 for auto switch weight.

Option Weights

Unit: g

Bore size (mm)		12	16	20	25	32
Rod end male thread	Male thread	1.5	3	6	12	26
	Nut	1	2	4	8	17
With rubber bumper		0	-1	-2	-3	-3

Bore size (mm)		40	50	63	80	100
Rod end male thread	Male thread	27	53	53	120	175
	Nut	17	32	32	49	116
With rubber bumper		-7	-9	-18	-31	-56

Minimum Strokes for Auto Switch Mounting

(mm)

No. of auto switches	D-F7□V D-J79C	D-A7□ D-A80 D-A73C D-A80C	D-F7□WV	D-A7□H D-A80H D-F7□ D-J79	D-A79W	D-F7□W D-J79W D-F7BAL D-F79F	D-F7LF
1	5	5	10	15	15	20	25
2	5	10	15	15	20	20	25

(Note) Refer to p.5.3-2 (CQ2 double acting) for auto switch specifications.

Construction

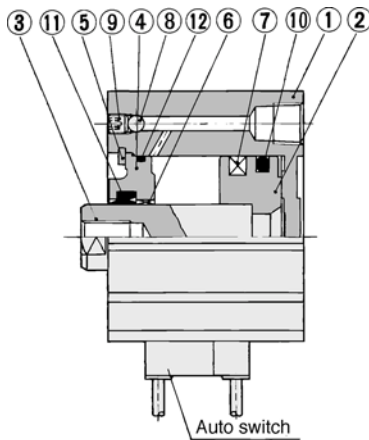

A-A section (Rod side port)

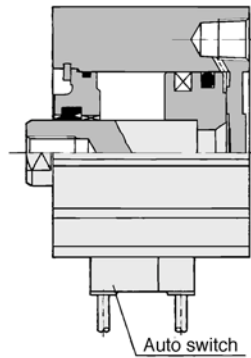

B-B section (Head side port)

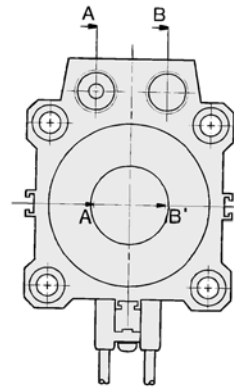

Component Part

No.	Description	Material	Note
①	Cylinder tube	Aluminum alloy	Hard anodized
②	Piston	Aluminum alloy	Chromated
③	Piston rod	Stainless steel	ø12 to ø25
		Carbon steel	ø32 to ø100, Hard chrome plated
④	Collar	Aluminum bearing alloy	ø12 to ø40, Anodized
		Aluminum alloy casting	ø50 to ø100, Chromated, coated
⑤	Snap ring	Carbon tool steel	Phosphate coating
⑥	Bushing	Lead bronze casting	Only used for ø50 or larger
⑦	Magnet	—	—
⑧	Steel ball	Bearing steel	—
⑨	Hex socket set screw	Alloy steel	Zinc chromated
⑩	Piston seal	NBR	—
⑪	Rod seal	NBR	—
⑫	Gasket	NBR	—

Replacement Parts: Seal Kits

Bore size (mm)	Kit No.		Note
	Pneumatic (non-lube)	Air-hydro	
12	CQ2B12-PS	—	A set of left nos. ⑩, ⑪ and ⑫
16	CQ2B16-PS	—	
20	CQ2B20-PS	CQ2BH20-PS	
25	CQ2B25-PS	CQ2BH25-PS	
32	CQ2B32-PS	CQ2BH32-PS	
40	CQ2B40-PS	CQ2BH40-PS	
50	CQ2B50-PS	CQ2BH50-PS	
63	CQ2B63-PS	CQ2BH63-PS	
80	CQ2B80-PS	CQ2BH80-PS	
100	CQ2B100-PS	CQ2BH100-PS	

* Seal kits are sets consisting of items ⑩, ⑪ and ⑫, which can be ordered using the order number for each cylinder bore size.

CUJ

CU

CQS

CQ2

RQ

MU

Series CQP2

Construction

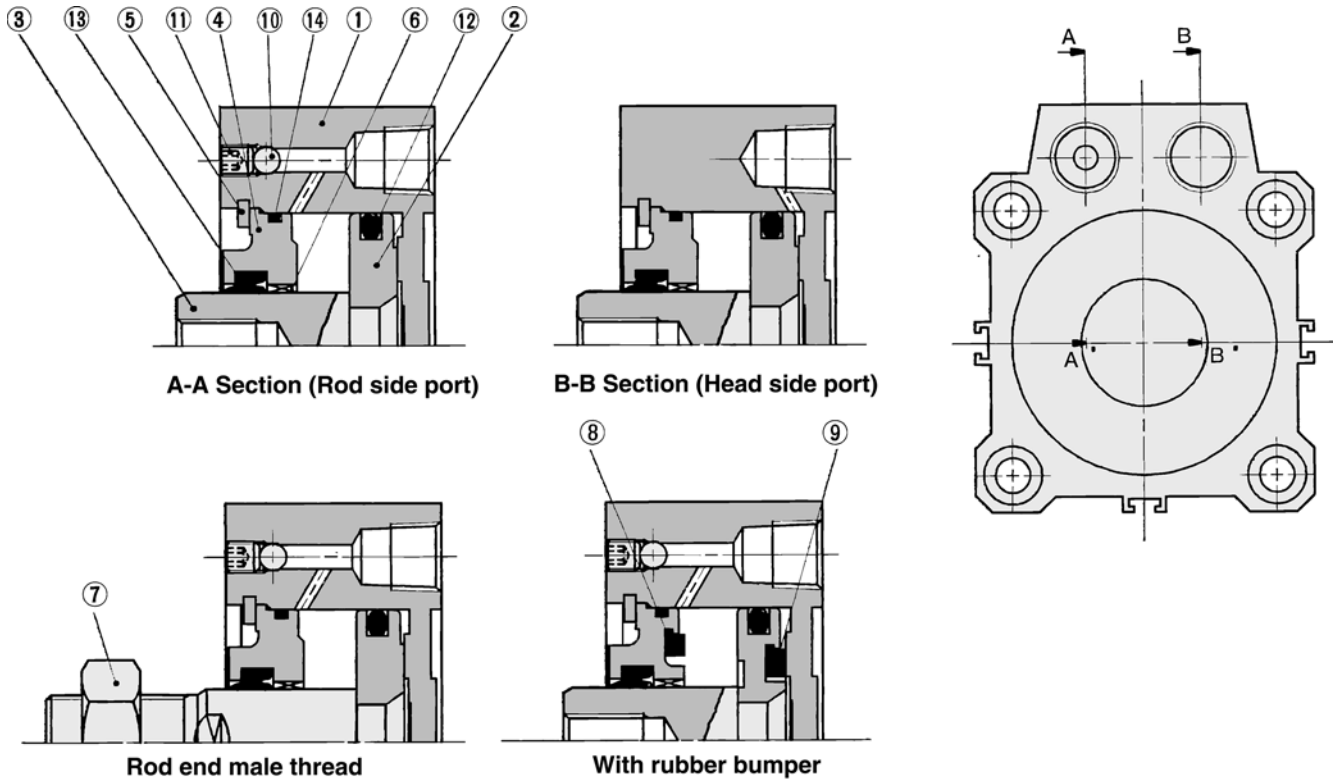

Component Parts

No.	Description	Material	Note
①	Cylinder tube	Aluminum alloy	Hard anodized
②	Piston *	Aluminum alloy	Chromated
③	Piston rod *	Stainless steel	ø12 to ø25
		Carbon steel	ø32 to ø100, Hard chrome plated
④	Collar	Aluminum bearing alloy	ø12 to ø40, Anodized
		Aluminum alloy casting	ø50 to ø100, Chromated, coated
⑤	Snap ring	Carbon tool steel	Phosphate coating
⑥	Bushing	Lead bronze casting	Only used for ø50 or larger
⑦	Rod end nut	Carbon steel	Nickel plated
⑧	Bumper A	Urethane	
⑨	Bumper B	Urethane	
⑩	Steel ball	Bearing steel	
⑪	Hexagon socket set screw	Alloy steel	Zinc chromated
⑫	Piston seal	NBR	
⑬	Rod seal	NBR	
⑭	Gasket	NBR	

* On bore size ø12 with rubber bumper style, piston and piston rod are integrated (Stainless steel).

Replacement Parts: Seal Kits

Bore size (mm)	Kit No.		Note
	Pneumatic (Non-lube)	Air-hydro	
12	CQ2B12-PS	—	A set of left nos. ⑫, ⑬ and ⑭.
16	CQ2B16-PS	—	
20	CQ2B20-PS	CQ2BH20-PS	
25	CQ2B25-PS	CQ2BH25-PS	
32	CQ2B32-PS	CQ2BH32-PS	
40	CQ2B40-PS	CQ2BH40-PS	
50	CQ2B50-PS	CQ2BH50-PS	
63	CQ2B63-PS	CQ2BH63-PS	
80	CQ2B80-PS	CQ2BH80-PS	
100	CQ2B100-PS	CQ2BH100-PS	

* Seal kits are sets consisting of items ⑫, ⑬ and ⑭, which can be ordered using the kit number for each cylinder bore size.

Copper Free

20 — CQP2B **Bore size** — **Stroke** D
 • Copper free series — ø12, ø16, ø20, ø25, ø32, ø40, ø50, ø63, ø80, ø100

To eliminate influences of copper ions or halogen ions during CRT manufacturing processes, copper and fluorine materials are not used as component parts.

Specifications

Action	Double acting single rod
Cylinder bore size	ø12, ø16, ø20, ø25, ø32, ø40, ø50, ø63, ø80, ø100
Proof Pressure	1.5MPa
Max. operating pressure	1.0MPa
Rubber bumper	None
Piping	Screw-in piping
Piston speed	50 to 500mm/s
Mounting	Through-hole
Auto switch	Mountable

Compact Cylinder/Axial Piping: Double Acting Single Rod Series **CDQP2**

Mounting Bolt for CDQP2 with Auto Switch

Special bolt for through-hole of CDQP2B mounting is available as option.
How to Order: Specify the required bolts.
Example) Bolt M3 X 35 ℓ 2pcs.

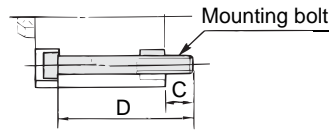

Model	C	D	Mounting bolt
CDQP2B12-5D	5.5	35	M3 X 35 ℓ
-10D		40	X 40 ℓ
-15D		45	X 45 ℓ
-20D		50	X 50 ℓ
-25D		55	X 55 ℓ
-30D		60	X 60 ℓ
CDQP2B16-5D	8	40	M3 X 40 ℓ
-10D		45	X 45 ℓ
-15D		50	X 50 ℓ
-20D		55	X 55 ℓ
-25D		60	X 60 ℓ
-30D		65	X 65 ℓ
CDQP2B20-5D	10.5	40	M5 X 40 ℓ
-10D		45	X 45 ℓ
-15D		50	X 50 ℓ
-20D		55	X 55 ℓ
-25D		60	X 60 ℓ
-30D		65	X 65 ℓ
-35D		70	X 70 ℓ
-40D		75	X 75 ℓ
-45D		80	X 80 ℓ
-50D		85	X 85 ℓ
CDQP2B25-5D	9.5	40	M5 X 40 ℓ
-10D		45	X 45 ℓ
-15D		50	X 50 ℓ
-20D		55	X 55 ℓ
-25D		60	X 60 ℓ
-30D		65	X 65 ℓ
-35D		70	X 70 ℓ
-40D		75	X 75 ℓ
-45D		80	X 80 ℓ
-50D		85	X 85 ℓ

Model	C	D	Mounting bolt
CDQP2B32-5D	9	40	M5 X 40 ℓ
-10D		45	X 45 ℓ
-15D		50	X 50 ℓ
-20D		55	X 55 ℓ
-25D		60	X 60 ℓ
-30D		65	X 65 ℓ
-35D		70	X 70 ℓ
-40D		75	X 75 ℓ
-45D		80	X 80 ℓ
-50D		85	X 85 ℓ
CDQP2B40-5D	7.5	45	M5 X 45 ℓ
-10D		50	X 50 ℓ
-15D		55	X 55 ℓ
-20D		60	X 60 ℓ
-25D		65	X 65 ℓ
-30D		70	X 70 ℓ
-35D		75	X 75 ℓ
-40D		80	X 80 ℓ
-45D		85	X 85 ℓ
-50D		90	X 90 ℓ
CDQP2B50-10D	12.5	55	M6 X 55 ℓ
-15D		60	X 60 ℓ
-20D		65	X 65 ℓ
-25D		70	X 70 ℓ
-30D		75	X 75 ℓ
-35D		80	X 80 ℓ
-40D		85	X 85 ℓ
-45D		90	X 90 ℓ
-50D		95	X 95 ℓ
-75D		120	X 120 ℓ
-100D	145	X 145 ℓ	

Model	C	D	Mounting bolt
CDQP2B63-10D	14.5	60	M8 X 60 ℓ
-15D		65	X 65 ℓ
-20D		70	X 70 ℓ
-25D		75	X 75 ℓ
-30D		80	X 80 ℓ
-35D		85	X 85 ℓ
-40D		90	X 90 ℓ
-45D		95	X 95 ℓ
-50D		100	X 100 ℓ
-75D		125	X 125 ℓ
CDQP2B80-10D	15	65	M10 X 65 ℓ
-15D		70	X 70 ℓ
-20D		75	X 75 ℓ
-25D		80	X 80 ℓ
-30D		85	X 85 ℓ
-35D		90	X 90 ℓ
-40D		95	X 95 ℓ
-45D		100	X 100 ℓ
-50D		105	X 105 ℓ
-75D		130	X 130 ℓ
CDQP2B100-10D	15.5	75	M10 X 75 ℓ
-15D		80	X 80 ℓ
-20D		85	X 85 ℓ
-25D		90	X 90 ℓ
-30D		95	X 95 ℓ
-35D		100	X 100 ℓ
-40D		105	X 105 ℓ
-45D		110	X 110 ℓ
-50D		115	X 115 ℓ
-75D		140	X 140 ℓ
-100D	165	X 165 ℓ	

CUJ

CU

CQS

CQ2

RQ

MU

Auto Switch Mounting Position (at Stroke End) and Mounting Height

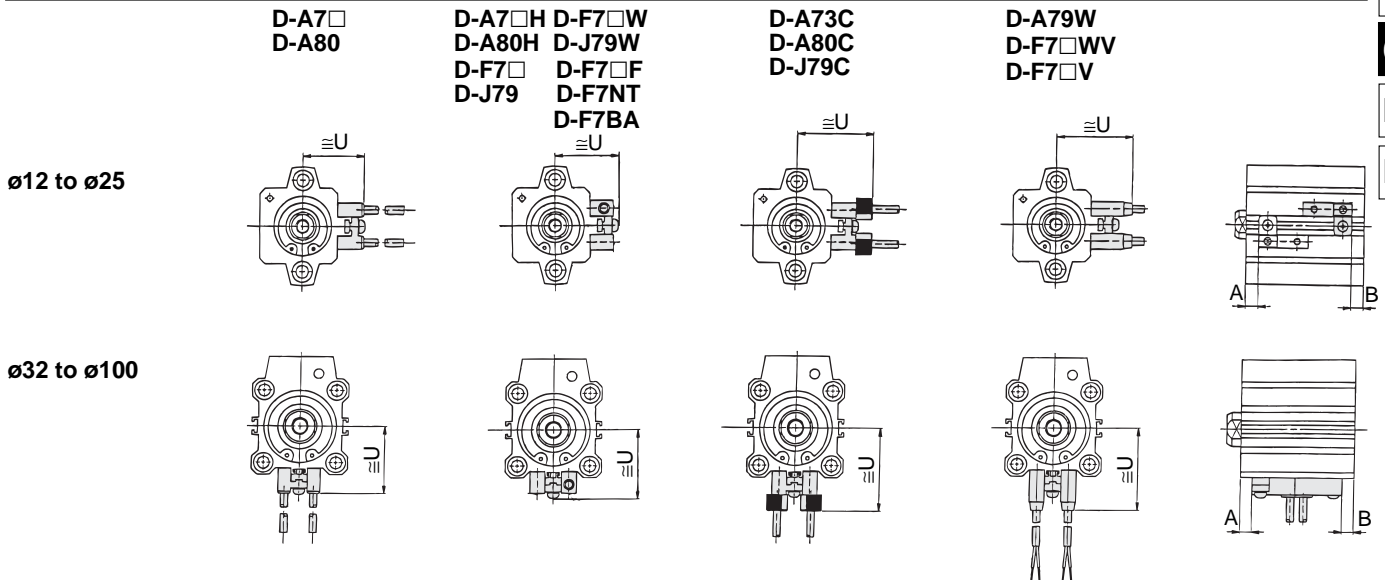

Auto Switch Mounting Position

Bore size (mm)	D-A7□ D-A80		D-A7□H/A80H D-A73C/A80C D-F7□/D-J79F□ J79C		D-A79W		D-F7BAL D-F7□W D-F7□F D-J79W D-F7□WV	
	A	B	A	B	A	B	A	B
12	4.5	5.5	5	6	2	3	9	10
16	7.5	5	8	5.5	5	2.5	12	9.5
20	7.5	6.5	8	7	5	4	12	11
25	7.5	7	8	7.5	5	4.5	12	11.5
32	9	6	9.5	6.5	6.5	3.5	13.5	10.5
40	13	8.5	13.5	9	10.5	6	17.5	13
50	11	11.5	11.5	12	8.5	9	15.5	16
63	13.5	14.5	14	15	11	12	18	19
80	17.5	18	18	18.5	15	15.5	22	22.5
100	21	24	21.5	24.5	18.5	21.5	25.5	28.5

Auto Switch Mounting Height

(mm)						
D-A7□ D-A80	D-A7□H/D-A80H D-F7□/D-J79F□W D-J79W/D-F7BAL D-F7□F/D-F7NTL		D-A73C D-A80C	D-F7□V D-F7□WV	D-J79C	D-A79W
U	U		U	U	U	U
19.5	20.5		26.5	23	26	22
22.5	23.5		29.5	26	29	25
24.5	25.5		31.5	28	31	27
27.5	28.5		34.5	31	34	30
31.5	32.5		38.5	35	38	34
35	36		42	38.5	41.5	37.5
41	42		48	44.5	47.5	43.5
47.5	48.5		54.5	51	54	50
57.5	58.5		64.5	61	64	60
67.5	68.5		74.5	71	74	70

Series CQP2

ø12 to ø100 Without Auto Switch

ø12 to ø25

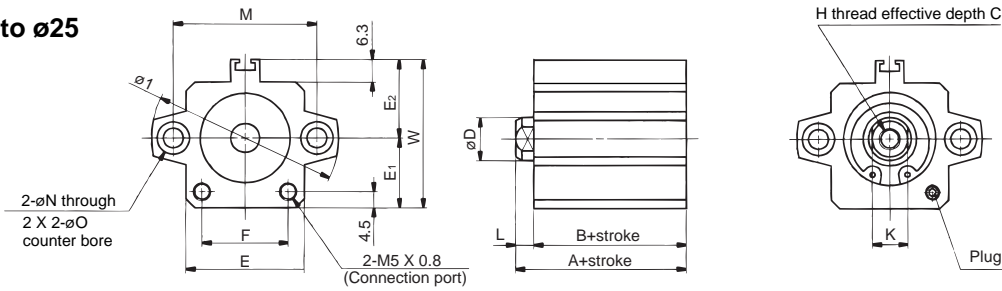

Rod end male thread

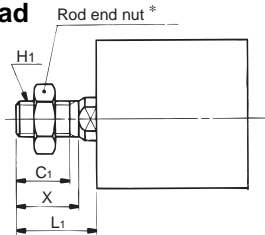

Rod end male thread (mm)

Bore (mm)	C1	X	H1	L1
12	9	10.5	M5 X 0.8	14
16	10	12	M6 X 1.0	15.5
20	12	14	M8 X 1.25	18.5
25	15	17.5	M10 X 1.25	22.5

Standard

Bore (mm)	Stroke range (mm)	A	B	C	D	E	E1	E2	F	H	I	K	L	M	N	O	W
12	5 to 30	20.5	17	6	6	23	13	14	14	M3 X 0.5	32	5	3.5	22	3.5	6.5 Depth 3.5	27
16	5 to 30	22	18.5	8	8	26	15	17	17	M4 X 0.7	38	6	3.5	28	3.5	6.5 Depth 3.5	32
20	5 to 50	24	19.5	7	10	30	17	19	21	M5 X 0.8	47	8	4.5	36	5.5	9 Depth 7	36
25	5 to 50	27.5	22.5	12	12	33	19.5	22	24	M6 X 1.0	52	10	5	40	5.5	9 Depth 7	41.5

ø32 to ø100

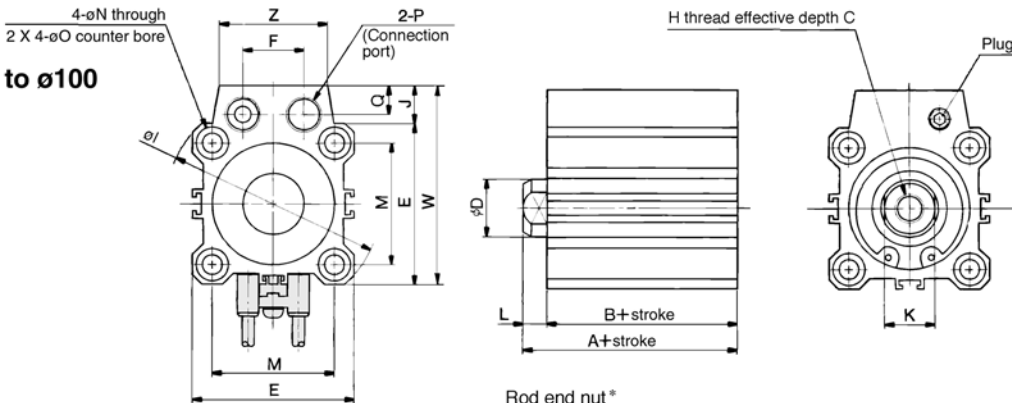

Rod end male thread

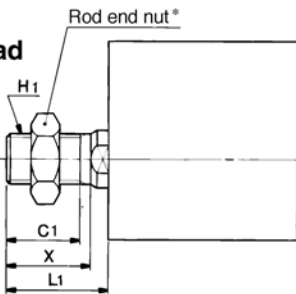

Rod end male thread (mm)

Bore (mm)	C1	X	H1	L1
32	20.5	23.5	M14 X 1.5	28.5
40	20.5	23.5	M14 X 1.5	28.5
50	26	28.5	M18 X 1.5	33.5
63	26	28.5	M18 X 1.5	33.5
80	32.5	35.5	M22 X 1.5	43.5
100	32.5	35.5	M26 X 1.5	43.5

Standard

Bore (mm)	Stroke range (mm)	A	B	C	D	E	F	H	I	J	K	L	M	N	O	P	Q	W	Z
32	5 to 50	30	23	13	16	45	17	M8 X 1.25	60	10.5	14	7	34	5.5	9 Depth 7	Rc(PT)1/8	8	55.5	30
	75,100	40	33																
40	5 to 50	36.5	29.5	13	16	52	17	M8 X 1.25	69	10	14	7	40	5.5	9 Depth 7	Rc(PT)1/8	8	62	30
	75,100	46.5	39.5																
50	10 to 50	38.5	30.5	15	20	64	22	M10 X 1.5	86	13	17	8	50	6.6	11 Depth 8	Rc(PT)1/4	10	77	39
	75,100	48.5	40.5																
63	10 to 50	44	36	15	20	77	22	M10 X 1.5	103	13	17	8	60	9	14 Depth 10.5	Rc(PT)1/4	10	90	39
	75,100	54	46																
80	10 to 50	53.5	43.5	21	25	98	26	M16 X 2.0	132	16	22	10	77	11	17.5 Depth 13.5	Rc(PT)3/8	12.5	114	48
	75,100	63.5	53.5																
100	10 to 50	65	53	27	30	117	26	M20 X 2.5	156	17.5	27	12	94	11	17.5 Depth 13.5	Rc(PT)3/8	12.5	134.5	48
	75,100	75	63																

Note) Dimensions with rubber bumper are the same, as the above.
 * Refer to p.2.3-18 & 19 for details of rod end nut and optional bracket.

Compact Cylinder/Axial Piping: Double Acting Single Rod **Series CDQP2**

ø12 to ø100 With Auto Switch

ø12 to ø25

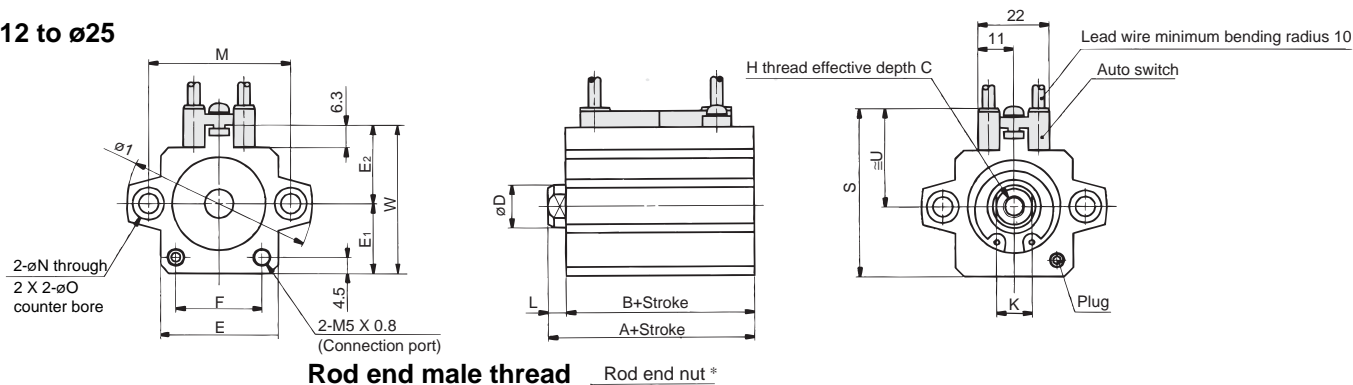

Rod end male thread

Rod end nut *

Rod end male thread (mm)

Bore (mm)	C ₁	X	H ₁	L ₁
12	9	10.5	M5 X 0.8	14
16	10	12	M6 X 1.0	15.5
20	12	14	M8 X 1.25	18.5
25	15	17.5	M10 X 1.25	22.5



Above auto switch: D-A80 Refer to p.2.3-87 for auto switch mounting position and mounting height.

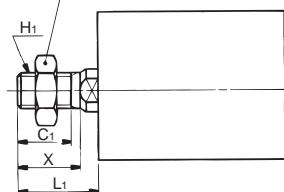

Standard

Bore (mm)	Stroke range (mm)	A	B	C	D	E	E ₁	E ₂	F	H	I	K	L	M	N	O	S	U	W
12	5 to 30	31.5	28	6	6	23	13	14	14	M3 X 0.5	32	5	3.5	22	3.5	6.5 Depth 3.5	32.5	19.5	27
16	5 to 30	34	30.5	8	8	26	15	17	17	M4 X 0.7	38	6	3.5	28	3.5	6.5 Depth 3.5	37.5	22.5	32
20	5 to 50	36	31.5	7	10	30	17	19	21	M5 X 0.8	47	8	4.5	36	5.5	9 Depth 7	41.5	24.5	36
25	5 to 50	37.5	32.5	12	12	33	19.5	22	24	M6 X 1.0	52	10	5	40	5.5	9 Depth 7	47	27.5	41.5

Note 1) Dimensions with rubber bumper are same as above standard type.

ø32 to ø100

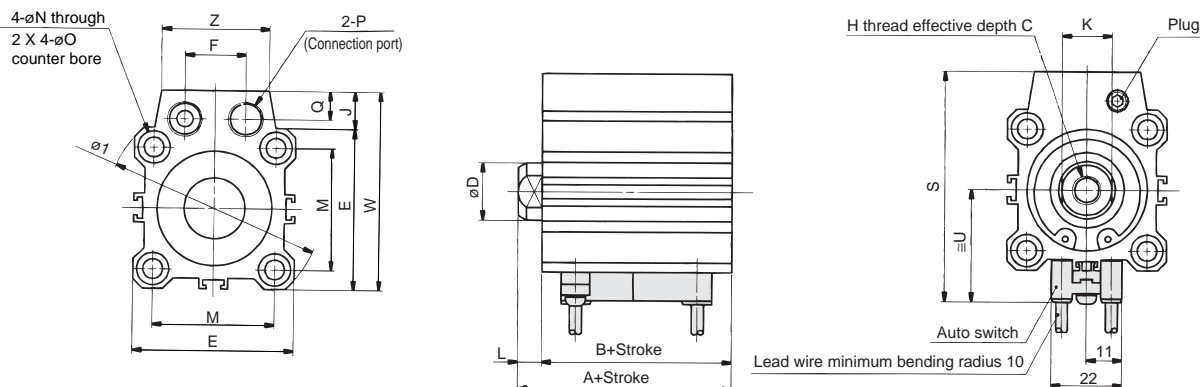

Rod end male thread

Rod end nut *

Rod end male thread (mm)

Bore (mm)	C ₁	X	H ₁	L ₁
32	20.5	23.5	M14 X 1.5	28.5
40	20.5	23.5	M14 X 1.5	28.5
50	26	28.5	M18 X 1.5	33.5
63	26	28.5	M18 X 1.5	33.5
80	32.5	35.5	M22 X 1.5	43.5
100	32.5	35.5	M26 X 1.5	43.5



Above auto switch: D-A80 Refer to p.2.3-87 for auto switch mounting position and mounting height.

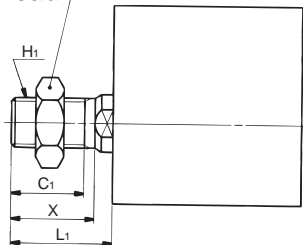

Standard

Bore (mm)	Stroke range (mm)	A	B	C	D	E	F	H	I	J	K	L	M	N	O	P	Q	S	U	W	Z
32	5 to 100	40	33	13	16	45	17	M8 X 1.25	60	10.5	14	7	34	5.5	9 Depth 7	Rc(PT)1/8	8	64.5	31.5	55.5	30
40	5 to 100	46.5	39.5	13	16	52	17	M8 X 1.25	69	10	14	7	40	5.5	9 Depth 7	Rc(PT)1/8	8	71	35	62	30
50	10 to 100	48.5	40.5	15	20	64	22	M10 X 1.5	86	13	17	8	50	6.6	11 Depth 8	Rc(PT)1/4	10	86	41	77	39
63	10 to 100	54	46	15	20	77	22	M10 X 1.5	103	13	17	8	60	9	14 Depth 10.5	Rc(PT)1/4	10	99	47.5	90	39
80	10 to 100	63.5	53.5	21	25	98	26	M16 X 2.0	132	16	22	10	77	11	17.5 Depth 13.5	Rc(PT)3/8	12.5	122.5	57.5	114	48
100	10 to 100	75	63	27	30	117	26	M20 X 2.5	156	17.5	27	12	94	11	17.5 Depth 13.5	Rc(PT)3/8	12.5	143.5	67.5	134.5	48

Note 1) Dimensions with rubber bumper are same as above standard type.

CUJ

CU

CQS

CQ2

RQ

MU

Compact Cylinder/Axial Piping: Single Acting Single Rod

Series CQP2

ø12, ø16, ø20, ø25, ø32, ø40, ø50

How to Order

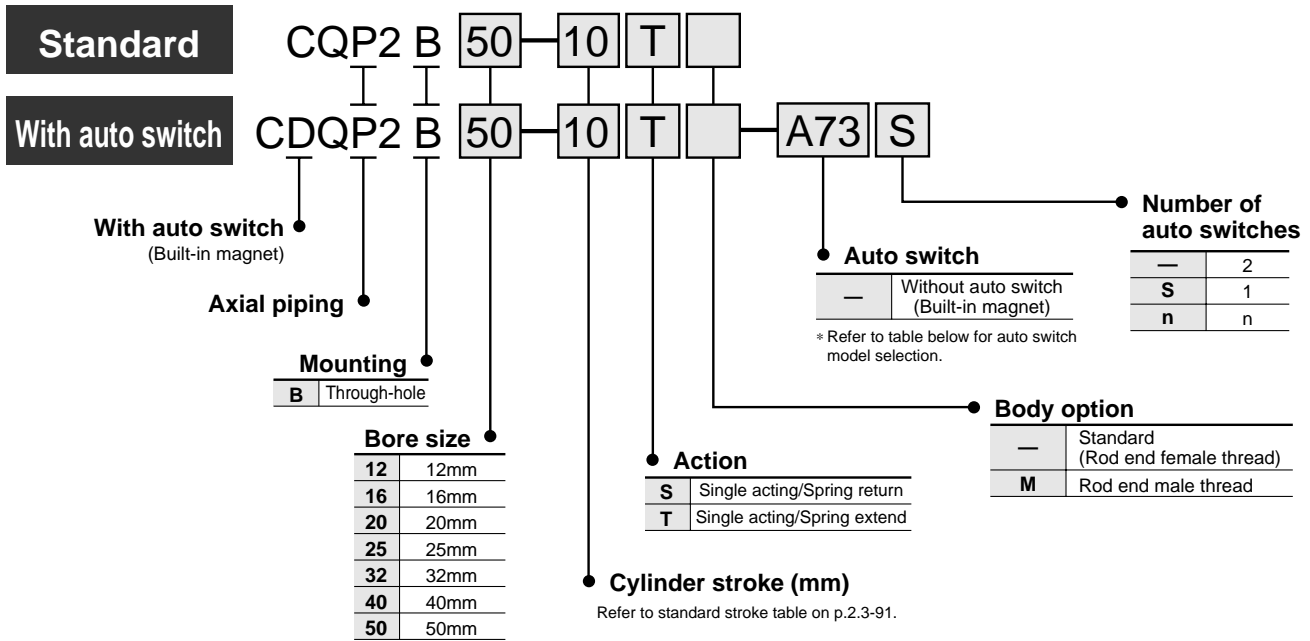

Applicable Auto Switches/Refer to p.5.3-2 for further information on auto switch.

Style	Special function	Electrical entry	Indicator	Wiring (Output)	Load voltage		Auto switch model		Lead wire (m)*				Applicable load							
					DC	AC	Parpendicular	In-line	0.5 (-)	3 (L)	5 (Z)	None (N)								
Reed switch	—	Grommet	Yes	3 wire (Equiv. NPN)	—	5V	—	—	A76H	●	●	—	—	IC						
						—	200V	A72	A72H	●	●	—	—	Relay, PLC						
						24V	12V	100V	A73	A73H	●	●	—		—					
							—	—	—	—	●	●	—		—					
						Connector	Yes	5V, 12V	≤ 100V	A80	A80H	●	●	—	—	IC				
							No	12V	—	A73C	—	●	●	●	●	—				
Diagnostic (2 colour)	Grommet	Yes	—	—	—	—	A80C	—	●	●	●	●	—	IC						
Solid state switch	—	Grommet	Yes	3 wire (NPN)	24V	5V, 12V	—	F7NV	F79	●	●	○	—	IC						
				3 wire (PNP)				F7PV	F7P	●	●	○	—	Relay, PLC						
				2 wire				F7BV	J79	●	●	○	—							
		Connector		Yes				12V	—	J79C	—	●	●		●	●	—			
		Diagnostic (2 colour)		Grommet				Yes	3 wire (NPN)	24V	5V, 12V	—	F7NWV	F79W	●	●	○	—	IC	
									3 wire (PNP)				—	F7PW	●	●	○	—	Relay, PLC	
	2 wire		—		F7BWV	J79W	●		●				○	—						
	Connector		Yes		12V	—	—		F7BA				—	●	○	—	—			
	Water resistant (2 colour)		Grommet		Yes	3 wire (NPN)	24V		5V, 12V				—	—	F7NT	—	●	○	—	—
	With timer					—								F7NF	—	●	○	—	IC	
	Diagnostic output (2 colour)	—		F79F		—		●		○	—	—								
	Latch with diagnostic output (2 colour)	Grommet	Yes	4 wire (NPN)	—	—	—	—	F7LF	●	●	○	—	—						

* Lead wire length 0.5m..... (Example) A80C 5m.....Z (Example) A80CZ
 3m..... L (Example) A80CL None.....N (Example) A80CN
 * Solid state switches marked with a "○" are manufactured upon receipt of order.

Compact Cylinder/Axial Piping: Single Acting Single Rod *Series CQP2*

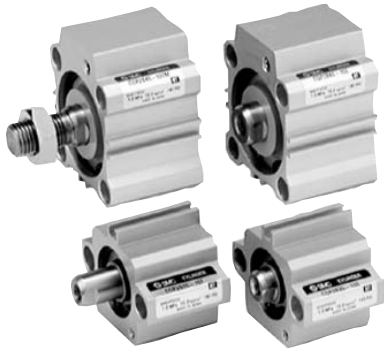

Style

Bore size (mm)		12	16	20	25	32	40	50	
Pneumatic	Mounting	Through-hole (Standard)	●	●	●	●	●	●	
	Built-in magnet		●	●	●	●	●	●	
	Piping	Screw-in	M5 X 0.8	M5 X 0.8	M5 X 0.8	M5 X 0.8	Rc(PT) 1/8	Rc(PT) 1/8	Rc(PT) 1/4
	Rod end male thread		●	●	●	●	●	●	●

Standard Specification

Style	Pneumatic (Non-lube)
Fluid	Air
Proof pressure	1.5MPa
Max. operating pressure	1.0MPa
Ambient and fluid temperature	Without auto switch: -10°C to 70°C (No freezing)
	With auto switch: -10°C to 60°C (No freezing)
Rubber bumper	None
Rod end thread	Female thread
Rod end thread tolerance	JIS class 2
Stroke length tolerance	+1.0 0
Mounting	Through-hole
Piston speed	50 to 500mm/s

JIS symbol

Single acting/
Spring return

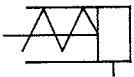

Single acting/
Spring extend



Minimum Operating Pressure

Unit: MPa

Bore size (mm)	12	16	20	25	32	40	50
Single acting (Spring return / Spring extend)	0.25	0.25	0.18	0.18	0.17	0.15	0.13

Standard Stroke

Unit: mm

Bore size	Standard stroke
12	5, 10
16	
20	
25	
32	
40	10, 20
50	

CUJ

CU

CQS

CQ2

RQ

MU

⚠ Precautions

Be sure to read before handling. Refer to p.0-39 to 0-46 for Safety Instructions and common precautions.

⚠ Caution

Snap Ring Installation/Removal

- For installation and removal, use an appropriate pair of pliers (tool for installing a C snap ring).
- Exercise caution even when using an appropriate pair of pliers (tool for installing a C snap ring), because of the possibility of the snap ring becoming detached from the tip of the pliers (tool for installing a C snap ring) and flying away, which could injure humans or damage the peripheral equipment. After installing the snap ring, make sure that it is placed securely in the ring groove before supplying air.

Auto Switch Mounting Bracket Part No.

Bore size (mm)	Part No.	Note	Applicable switch	
			Reed switch	Solid state switch
12, 16 20, 25	BQ-1	<ul style="list-style-type: none"> Switch mounting screw (M3 X 0.5 X 8 ℓ) Square nut 	D-A7□, A80 D-A73C, A80C	D-F7□, J79 D-F7□V D-J79C D-F7□W, J79W
32, 40 50	BQ-2	<ul style="list-style-type: none"> Switch mounting screw (M3 X 0.5 X 10 ℓ) Switch interface Switch mounting nut 	D-A7□H, A80H D-A79W	D-F7□WV D-F7BAL D-F7□F D-F7NTL



*Stainless steel mounting bolt set

The set of stainless steel mounting screws (with nut) described below is available and can be used depending on the operating environment. (The spacer for auto switches must be ordered separately, as they are not included.)

BBA2: For D-A7/A8/F7/J7

The stainless steel bolts described above are used when the D- F7BAL type switch is shipped mounted on a cylinder. When the switches are shipped as individual parts, the BBA2 set is included.

Series CQP2

Theoretical Force

Unit: N

Action	Bore size (mm)	Operating pressure (MPa)		
		0.3	0.5	0.7
Spring return	12	21	44	66
	16	45	86	126
	20	79	142	205
	25	126	224	323
	32	211	372	533
	40	338	589	841
	50	535	928	1316
Spring extend	12	14	31	48
	16	24	54	85
	20	71	118	165
	25	113	189	264
	32	181	302	422
	40	317	528	739
	50	495	825	1150

Refer to p.5.6-3 for spring force.

Mounting Bolt for CQP2

Special bolt for through-hole mounting of CQP2B is available as option
How to Order: Specify the required bolts.

Example) Bolt M3 X 25 ℓ 4pcs.

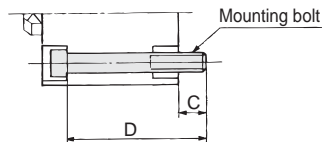

Spring return

Model	C	D	Mounting bolt
CQP2B12-5S	6.5	25	M3 X 25 ℓ
-10S		30	X 30 ℓ
CQP2B16-5S	5	25	M3 X 25 ℓ
-10S		30	X 30 ℓ
CQP2B20-5S	7.5	25	M5 X 25 ℓ
-10S		30	X 30 ℓ
CQP2B25-5S	9.5	30	M5 X 30 ℓ
-10S		35	X 35 ℓ
CQP2B32-5S	9	30	M5 X 30 ℓ
-10S		35	X 35 ℓ
CQP2B40-5S	7.5	35	M5 X 35 ℓ
-10S		40	X 40 ℓ
CQP2B50-10S	12.5	45	M6 X 45 ℓ
-20S		55	X 55 ℓ

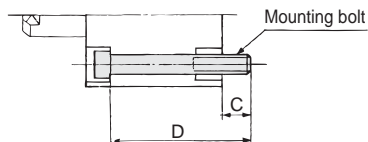

Spring extend

Model	C	D	Mounting bolt
CQP2B12-5T	6.5	25	M3 X 25 ℓ
-10T		30	X 30 ℓ
CQP2B16-5T	5	25	M3 X 25 ℓ
-10T		30	X 30 ℓ
CQP2B20-5T	7.5	25	M5 X 25 ℓ
-10T		30	X 30 ℓ
CQP2B25-5T	9.5	30	M5 X 30 ℓ
-10T		35	X 35 ℓ
CQP2B32-5T	9	30	M5 X 30 ℓ
-10T		35	X 35 ℓ
CQP2B40-5T	7.5	35	M5 X 35 ℓ
-10T		40	X 40 ℓ
CQP2B50-10T	12.5	45	M6 X 45 ℓ
-20T		55	X 55 ℓ

Weight

Unit: g

Action	Bore size (mm)	Cylinder stroke (mm)			
		5	10	15	20
Spring return	12	33	40	—	—
	16	55	64	—	—
	20	68	83	—	—
	25	103	118	—	—
	32	149	173	—	—
	40	236	262	—	—
	50	—	426	—	691
Spring extend	12	33	40	—	—
	16	55	64	—	—
	20	73	87	—	—
	25	109	124	—	—
	32	160	180	—	—
	40	262	284	—	—
	50	—	468	—	540

Option Weights

Unit: g

Bore size (mm)		12	16	20	25	32	40	50
Rod end male thread	Male thread	1.5	3	6	12	26	27	53
	Nut	1	2	4	8	17	17	32

Calculation example: CQP2B32-10SM

Basic weight: CQP2B32-10S173g

Additional weight: Rod end male thread 43g

216g

Compact Cylinder/Axial Piping: Single Acting Single Rod *Series CQP2*

Construction

Spring return

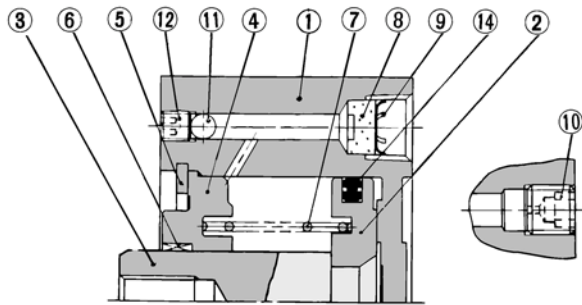

A-A section (Rod side port)

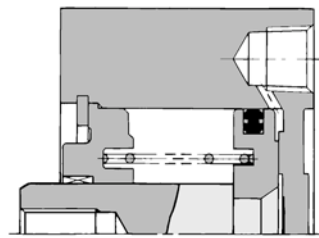

B-B section (Head side port)

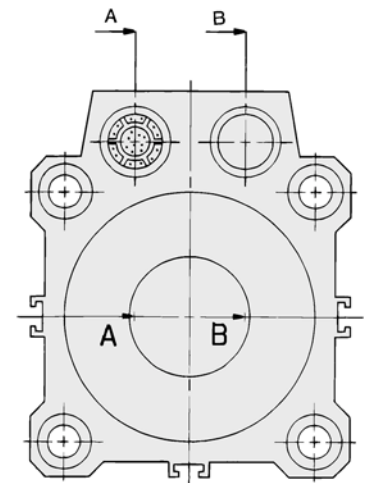

Spring extend

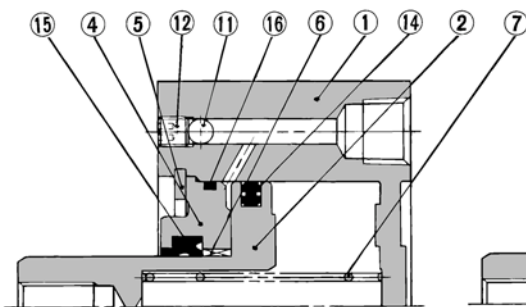

A-A section (Rod side port)

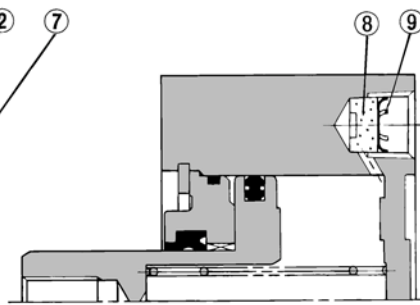

B-B section (Head side port)

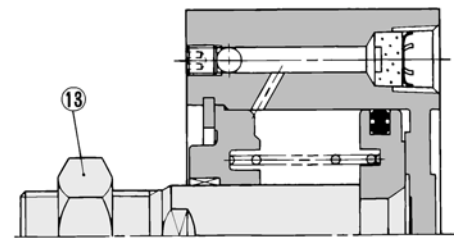

Rod end male thread

Component Parts

No.	Description	Material	Note
①	Cylinder tube	Aluminum alloy	Hard anodized
②*	Piston	Aluminum alloy	Chromated
③	Piston rod	Stainless steel	ø12 to ø25
		Carbon steel	ø32 to ø50, Hard chrome plated
④	Collar	Aluminum bearing alloy	ø12 to ø40, Anodized
		Aluminum alloy casting	ø50, Chromated, coated
⑤	Snap ring	Carbon tool steel	Phosphate coating
⑥	Bushing	Lead bronze casting	Used for only ø50
⑦	Return spring	Piano wire	Zinc chromated
⑧	Bronze element	Sintered metal BC	Port size Rc(PT)1/8, 1/4
⑨	Snap ring	Carbon tool steel	
⑩	Plug with fixed orifice	Alloy steel	Port size M5 X 0.8
⑪	Steel ball	Carbon steel	
⑫	Hexagon socket set screw	Alloy steel	Zinc chromated
⑬	Rod end nut	Carbon steel	Nickel plated
⑭	Piston seal	NBR	
⑮	Rod seal	NBR	
⑯	Gasket	NBR	

* On spring extend (T type), piston and piston rod are integrated (Stainless steel).

Replacement Parts: Seal Kits

Bore size (mm)	Kit No.	Contents
12	CQ2B12-PS	A set includes ⑭, ⑮ and ⑯.
16	CQ2B16-PS	
20	CQ2B20-PS	
25	CQ2B25-PS	
32	CQ2B32-PS	
40	CQ2B40-PS	
50	CQ2B50-PS	

* Seal kits are sets consisting of items ⑭, ⑮ and ⑯, which can be ordered using the kit number for each cylinder bore size.

Copper Free

20 — CQP2B Bore size — Stroke $\frac{S}{T}$ (M)
 • Copper free • ø12, ø16, ø20, ø25, ø32, ø40, ø50

To eliminate influences of copper ions or halogen ions during CRT manufacturing processes, copper and fluorine materials are not used as component parts.

Specifications

Action	Single acting single rod
Cylinder bore size	ø12, ø16, ø20, ø25, ø32, ø40, ø50
Proof pressure	1.5MPa
Max. operating pressure	1.0MPa
Rubber bumper	None
Piping	Screw-in piping
Piston speed	50 to 500mm/s
Mounting	Through-hole
Auto switch	Mountable

Series CDQP2 Auto Switch Specifications

* Refer to p.5.3-2 for details of auto switch.

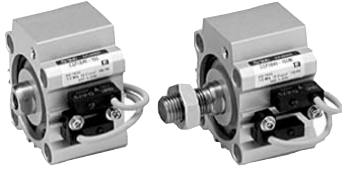

Minimum Strokes for Auto Switch Mounting

(mm)

No. of auto switches	D-F7□V D-J79C	D-A7□ D-A80 D-A73C D-A80C	D-F7□WV	D-A7□H D-A80H D-F7□ D-J79	D-A79W	D-F7□W D-J79W D-F7BAL D-F79F
1	5	5	10	15	15	20
2	5	10	15	15	20	20

Refer to p.5.3-2 (CQ2 Double Acting) for auto switch specifications.

Weight

Unit: g

Action	Bore size (mm)	Cylinder stroke (mm)			
		5	10	15	20
Spring return	12	55	63	—	—
	16	92	100	—	—
	20	121	135	—	—
	25	178	191	—	—
	32	217	242	—	—
	40	323	349	—	—
Spring extend	12	61	69	—	—
	16	92	100	—	—
	20	126	140	—	—
	25	184	197	—	—
	32	228	253	—	—
	40	349	375	—	—
	50	—	600	—	683

Option Weights

Unit: g

Bore size (mm)		12	16	20	25	32	40	50
Rod end	Male thread	1.5	3	6	12	26	27	53
	Nut	1	2	4	8	17	17	32

Calculation example: CDQP2B32-10SM

• Basic weight: CDQP2B32-10S.....242g

• Additional weight: Rod end male thread.....43g
285g

Add each weight of auto switches and mounting brackets when auto switches are mounted.

Weight/Auto Switch Mounting Bracket

Bracket part.	Bore size	Weight (g)
BQ-1	ø12 to ø25	1.5
BQ-2	ø32 to ø50	1.5

* Refer to p.5.3-75 for auto switch weight.

Construction

Spring return

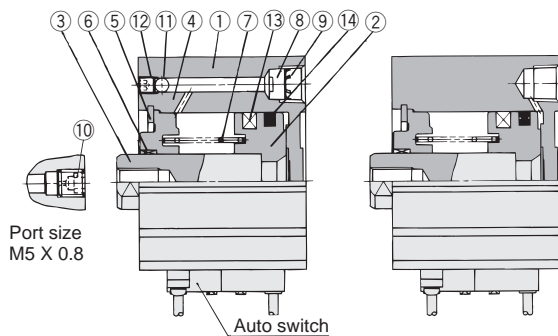

Spring extend

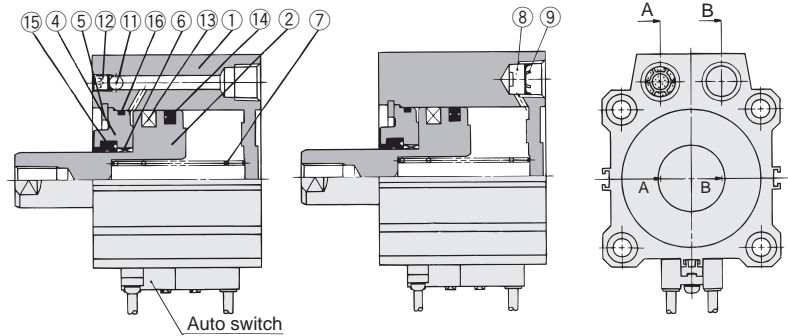

A-A section (Rod side port) B-B section (Head side port) A-A section (Rod side port) B-B section (Head side port)

Component Parts

No.	Description	Material	Note
①	Cylinder tube	Aluminum alloy	Hard anodized
②	Piston *	Aluminum alloy	Chromated
③	Piston rod *	Stainless steel	ø12 to ø25
		Carbon steel	ø32 to ø50, Hard chrome plated
④	Collar	Aluminum bearing alloy	ø12 to ø40, Anodized
		Aluminum alloy casting	ø50, Chromate, coated
⑤	Snap ring	Carbon tool steel	Phosphate coating
⑥	Bushing	Lead bronze casting	Used for only ø50
⑦	Return spring	Piano wire	Zinc chromated
⑧	Bronze element	Sintered metal BC	Port size Rc(PT)1/8, 1/4
⑨	Snap ring	Carbon tool steel	
⑩	Plug with fixed orifice	Alloy steel	Port size M5 X 0.8
⑪	Steel ball	Bearing steel	
⑫	Hexagon socket set screw	Alloy steel	Zinc chromated
⑬	Magnet	—	
⑭	Piston seal	NBR	
⑮	Rod seal	NBR	
⑯	Gasket	NBR	

* On spring extend (T type), piston and piston rod are integrated (Stainless steel).

Replacement Parts: Seal Kits

Bore size (mm)	Kit No.	Contents
12	CQ2B12-PS	A set includes. ⑭, ⑮ and ⑯
16	CQ2B16-PS	
20	CQ2B20-PS	
25	CQ2B25-PS	
32	CQ2B32-PS	
40	CQ2B40-PS	
50	CQ2B50-PS	

* Seal kits are sets consisting of items ⑭, ⑮ and ⑯, which can be ordered using the kit number for each cylinder bore size.

Compact Cylinder/Axial Piping: Single Acting Single Rod *Series CDQP2*

Mounting Bolt for CDQP2 with Auto Switch

Special bolt for through-hole mounting of CDQP2B is available as option.

How to Order: Specify the required bolts
Example) Bolt M3 X 35 ℓ 2 pcs.

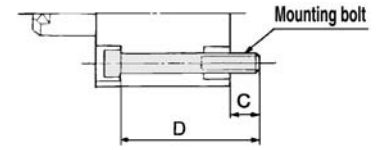
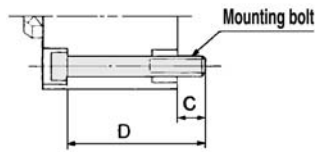

Spring return

Model	C	D	Mounting bolt
CDQP2B12-5S	5.5	35	M3 X 35 ℓ
-10S		40	X 40 ℓ
CDQP2B16-5S	8	40	M3 X 40 ℓ
-10S		45	X 45 ℓ
CDQP2B20-5S	10.5	40	M5 X 40 ℓ
-10S		45	X 45 ℓ
CDQP2B25-5S	9.5	40	M5 X 40 ℓ
-10S		45	X 45 ℓ
CDQP2B32-5S	9	40	M5 X 40 ℓ
-10S		45	X 45 ℓ
CDQP2B40-5S	7.5	45	M5 X 45 ℓ
-10S		50	X 50 ℓ
CDQP2B50-10S	12.5	55	M6 X 55 ℓ
-20S		60	X 60 ℓ

Spring extend

Model	C	D	Mounting bolt
CDQP2B12-5T	6.1	40	M3 X 40 ℓ
-10T		45	X 45 ℓ
CDQP2B16-5T	8	40	M3 X 40 ℓ
-10T		45	X 45 ℓ
CDQP2B20-5T	10.5	40	M5 X 40 ℓ
-10T		45	X 45 ℓ
CDQP2B25-5T	9.5	40	M5 X 40 ℓ
-10T		45	X 45 ℓ
CDQP2B32-5T	9	40	M5 X 40 ℓ
-10T		45	X 45 ℓ
CDQP2B40-5T	7.5	45	M5 X 45 ℓ
-10T		50	X 50 ℓ
CDQP2B50-10T	12.5	55	M6 X 55 ℓ
-20T		65	X 65 ℓ

Auto Switch Mounting position (at Stroke End) and Mounting Height

D-A7□
D-A80

D-A7□H D-F7□W
D-A80H D-J79W
D-F7□ D-F7□F
D-J79 D-F7NTL
D-F7BAL

D-A73C
D-A80C
D-J79C

D-A79W
D-F7□WV
D-F7□V

ø12 to ø25

ø32 to ø100

CUJ

CU

CQS

CQ2

RQ

MU

Auto Switch Mounting Position/Spring return (Spring extend)

Bore size (mm)	D-A7□ D-A80		D-A7□H/A80H D-A73C/A80C D-F7□ J79 D-F7□V/J79C		D-A79W		D-F7BAL D-F7□W D-F7□F D-J79W D-F7□WV	
	A	B	A	B	A	B	A	B
12	4.5	5.5(10)	5	6(10.5)	2	3(7.5)	9	10(14.5)
16	7.5(5.5)	5(7)	8(6)	5.5(7.5)	5(3)	2.5(4.5)	12(10)	9.5(11.5)
20	7.5	6.5	8	7	5	4	12	11
25	7.5	7	8	7.5	5	4.5	12	11.5
32	9	6	9.5	6.5	6.5	3.5	13.5	10.5
40	13	8.5	13.5	9	10.5	6	17.5	13
50	11	11.5	11.5	12	8.5	9	15.5	16

(): Spring extend

Auto Switch Mounting Height

(mm)

D-A7□ D-A80	D-A7□H/D-A80H D-F7□ D-J79/D-F7□W D-J79W/D-F7BAL D-F7□F/D-F7NTL	D-A73C D-A80C	D-F7□V D-F7□WV	D-J79C	D-A79W
U	U	U	U	U	U
19.5	20.5	26.5	23	26	22
22.5	23.5	29.5	26	29	25
24.5	25.5	31.5	28	31	27
27.5	28.5	34.5	31	34	30
31.5	32.5	38.5	35	38	34
35	36	42	38.5	41.5	37.5
41	42	48	44.5	47.5	43.5

Series CQP2

ø12 to ø50 Spring Return Without Auto Switch

ø12 to ø25

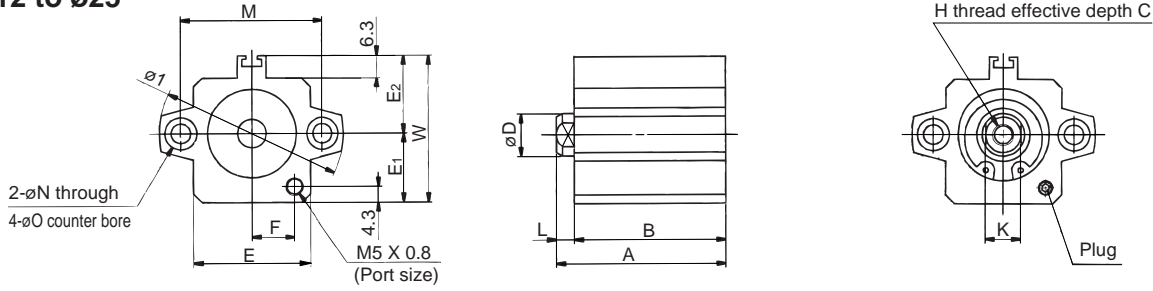

Rod end male thread

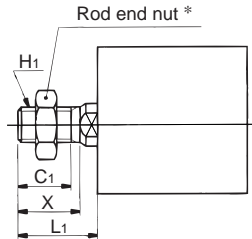

Rod end male thread (mm)

Bore (mm)	C1	X	H1	L1
12	9	10.5	M5 X 0.8	14
16	10	12	M6 X 1.0	15.5
20	12	14	M8 X 1.25	18.5
25	15	17.5	M10 X 1.25	22.5

Standard

(mm)

Bore (mm)	A		B		C	D	E	E1	E2	F	H	I	K	L	M	N	O	W
	5st	10st	5st	10st														
12	25.5	30.5	22	27	6	6	23	13	14	7	M3 X 0.5	32	5	3.5	22	3.5	6.5 Depth 3.5	27
16	27	32	23.5	28.5	8	8	26	15	17	8.5	M4 X 0.7	38	6	3.5	28	3.5	6.5 Depth 3.5	32
20	29	34	24.5	29.5	7	10	30	17	19	10.5	M5 X 0.8	47	8	4.5	36	5.5	9 Depth 7	36
25	32.5	37.5	27.5	32.5	12	12	33	19.5	22	12	M6 X 1.0	52	10	5	40	5.5	9 Depth 7	41.5

ø32 to ø50

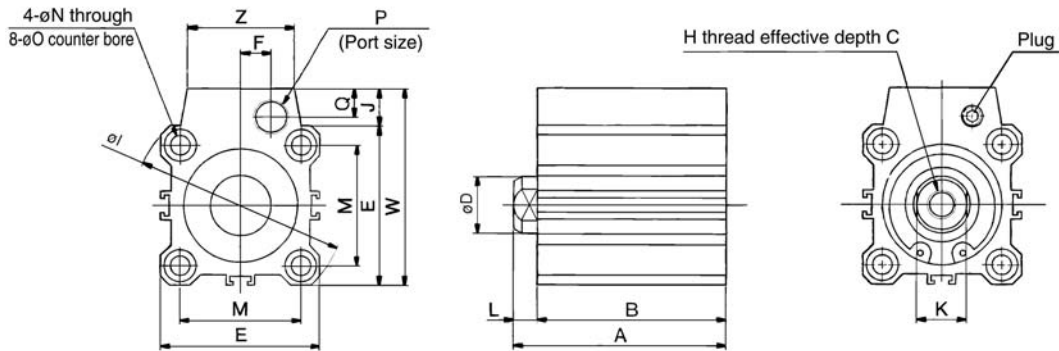

Rod end male thread

Rod end nut*

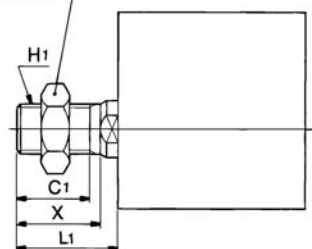

Rod end male thread (mm)

Bore (mm)	C1	X	H1	L1
32	20.5	23.5	M14 X 1.5	28.5
40	20.5	23.5	M14 X 1.5	28.5
50	26	28.5	M18 X 1.5	33.5

Standard

(mm)

Bore (mm)	A			B			C	D	E	F	H	I	J	K	L	M	N	O	P	Q	W	Z
	5st	10st	20st	5st	10st	20st																
32	35	40	—	28	33	—	13	16	45	8.5	M8 X 1.25	60	10.5	14	7	34	5.5	9 Depth 7	1/8	8	55.5	30
40	41.5	46.5	—	34.5	39.5	—	13	16	52	8.5	M8 X 1.25	69	10	14	7	40	5.5	9 Depth 7	1/8	8	62	30
50	—	48.5	58.5	—	40.5	50.5	15	20	64	11	M10 X 1.5	86	13	17	8	50	6.6	11 Depth 8	1/4	10	77	39

* Refer to p.2.3-18 & 19 for rod end nut and optional bracket.

ø12 to ø50 Spring Return With Auto Switch

ø12 to ø25

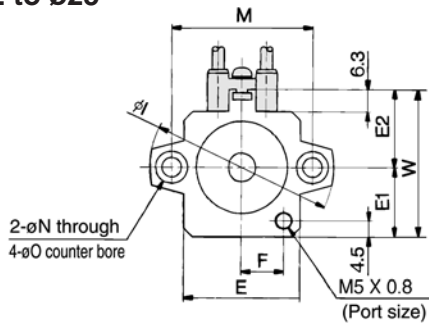

Rod end male thread

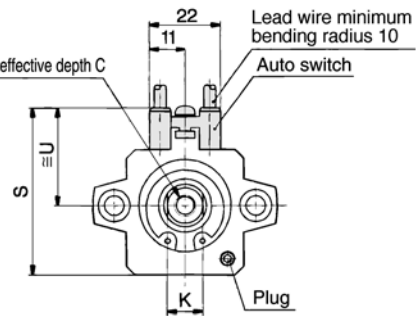
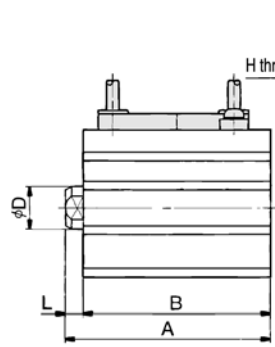

Above auto switch: D-A73/A80
Refer to p.2.3-95 for auto switch mounting position and mounting height.

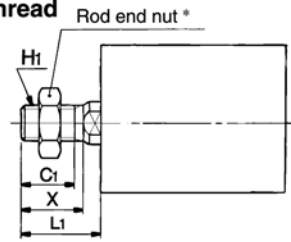

Rod end male thread (mm)

Bore (mm)	C1	X	H1	L1
12	9	10.5	M5 X 0.8	14
16	10	12	M6 X 1.0	15.5
20	12	14	M8 X 1.25	18.5
25	15	17.5	M10 X 1.25	22.5

Standard

Bore (mm)	A		B		C	D	E	E1	E2	F	H	I	K	L	M	N	O	S	U	W
	5st	10st	5st	10st																
12	36.5	41.5	33	38	6	6	23	13	14	7	M3 X 0.5	32	5	3.5	22	3.5	6.5 Depth 3.5	32.5	19.5	27
16	39	44	35.5	40.5	8	8	26	15	17	8.5	M4 X 0.7	38	6	3.5	28	3.5	6.5 Depth 3.5	37.5	22.5	32
20	41	46	36.5	41.5	7	10	30	17	19	10.5	M5 X 0.8	47	8	4.5	36	5.5	9 Depth 7	41.5	24.5	36
25	42.5	47.5	37.5	42.5	12	12	33	19.5	22	12	M6 X 1.0	52	10	5	40	5.5	9 Depth 7	47	27.5	41.5

ø32 to ø50

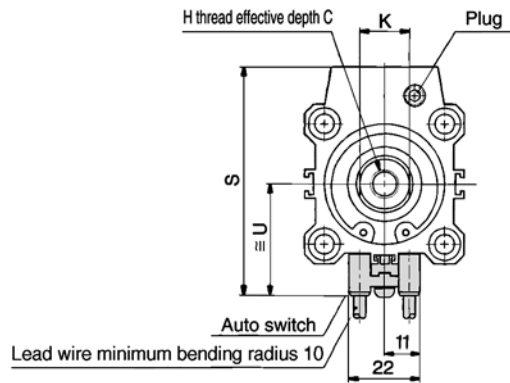
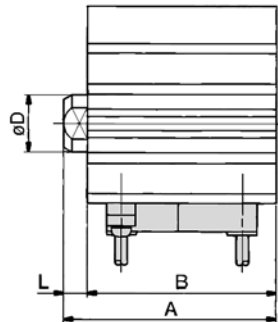
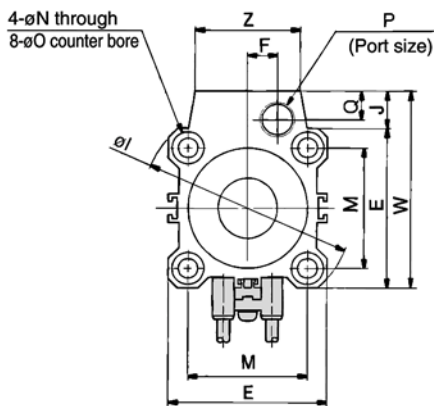

Above auto switch: D-A73/A80
Refer to p.2.3-95 for auto switch mounting position and mounting height.

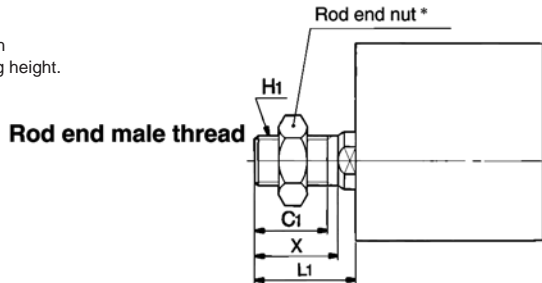

Rod end male thread (mm)

Bore (mm)	C1	X	H1	L1
32	20.5	23.5	M14 X 1.5	28.5
40	20.5	23.5	M14 X 1.5	28.5
50	26	28.5	M18 X 1.5	33.5

Standard

Bore (mm)	A			B			C	D	E	F	H	I	J	K	L	M	N	O	P	Q	S	U	W	Z
	5st	10st	20st	5st	10st	20st																		
32	45	50	—	38	43	—	13	16	45	8.5	M8 X 1.25	60	10.5	14	7	34	5.5	9 Depth 7	1/8	8	64.5	31.5	55.5	30
40	51.5	56.5	—	44.5	49.5	—	13	16	52	8.5	M8 X 1.25	69	10	14	7	40	5.5	9 Depth 7	1/8	8	71	35	62	30
50	—	58.5	68.5	—	50.5	60.5	15	20	64	11	M10 X 1.5	86	13	17	8	50	6.6	11 Depth 8	1/4	10	86	41	77	39

* Refer to p.2.3-18 & 19 for rod end nut and optional bracket.

CUJ

CU

CQS

CQ2

RQ

MU

Series CQP2

ø12 to ø50 Spring Extend Without Auto Switch

ø12 to ø25

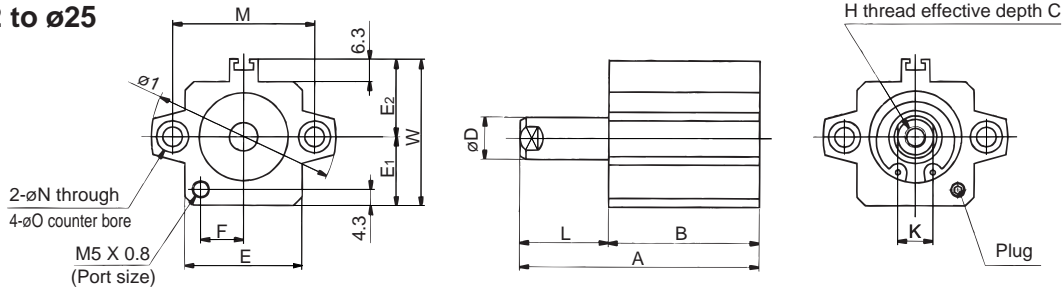

Rod end male thread

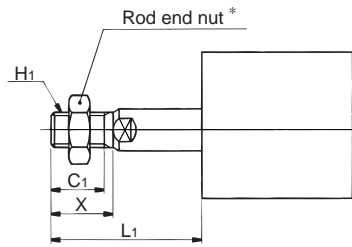

Rod end male thread (mm)

Bore (mm)	C1	H1	L1		X
			5st	10st	
12	9	M5 X 0.8	19	24	10.5
16	10	M6 X 1.0	20.5	25.5	12
20	12	M8 X 1.25	23.5	28.5	14
25	15	M10 X 1.25	27.5	32.5	17.5

Standard

Bore (mm)	A		B		C	D	E	E1	E2	F	H	I	K	L			M	N	O	W
	5st	10st	5st	10st										5st	10st					
12	30.5	40.5	22	27	6	6	23	13	14	7	M3 X 0.5	32	5	8.5	13.5	22	3.5	6.5 Depth 3.5	27	
16	32	42	23.5	28.5	8	8	26	15	17	8.5	M4 X 0.7	38	6	8.5	13.5	28	3.5	6.5 Depth 3.5	32	
20	34	44	24.5	29.5	7	10	30	17	19	10.5	M5 X 0.8	47	8	9.5	14.5	36	5.5	9 Depth 7	36	
25	37.5	47.5	27.5	32.5	12	12	33	19.5	22	12	M6 X 1.0	52	10	10	15	40	5.5	9 Depth 7	41.5	

ø32 to ø50

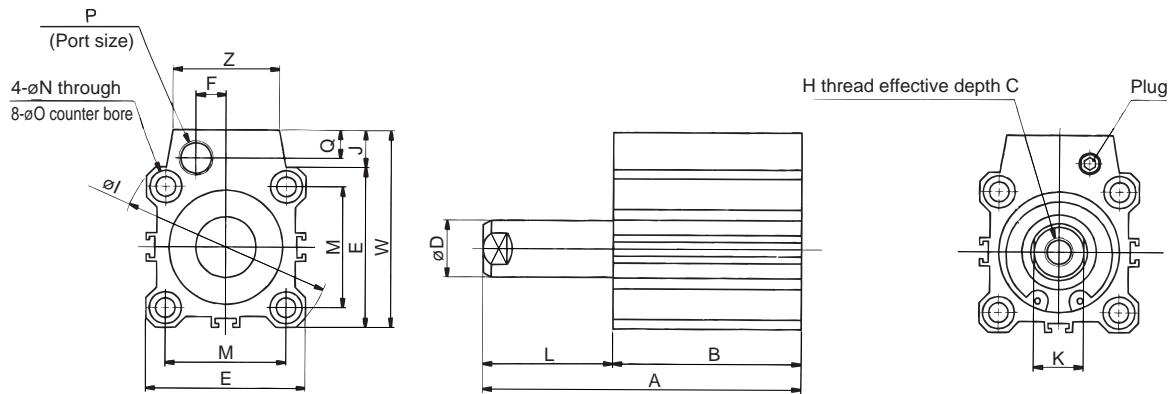

Rod end male thread

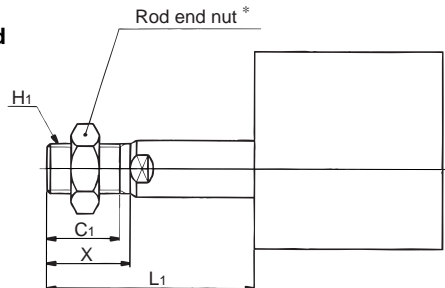

Rod end male thread (mm)

Bore (mm)	C1	X	H1	L1		
				5st	10st	20st
32	20.5	23.5	M14 X 1.5	33.5	38.5	—
40	20.5	23.5	M14 X 1.5	33.5	38.5	—
50	26	28.5	M18 X 1.5	—	43.5	53.5

Standard

Bore (mm)	A			B			C	D	E	F	H	I	J	K	L			M	N	O	P	Q	W	Z
	5st	10st	20st	5st	10st	20st									5st	10st	20st							
32	40	50	—	28	33	—	13	16	45	8.5	M8 X 1.25	60	10.5	14	12	17	—	34	5.5	9 Depth 7	1/8	8	55.5	30
40	46.5	56.5	—	34.5	39.5	—	13	16	52	8.5	M8 X 1.25	69	10	14	12	17	—	40	5.5	9 Depth 7	1/8	8	62	30
50	—	58.5	78.5	—	40.5	50.5	15	20	64	11	M10 X 1.5	86	13	17	—	18	28	50	6.6	11 Depth 8	1/4	10	77	39

* Refer to p.2.3-18 & 19 for rod end nut and option bracket.

Compact Cylinder/Axial Piping: Single Acting Single Rod **Series CDQP2**

ø12 to ø50 Spring Extend With Auto Switch

ø12 to ø25

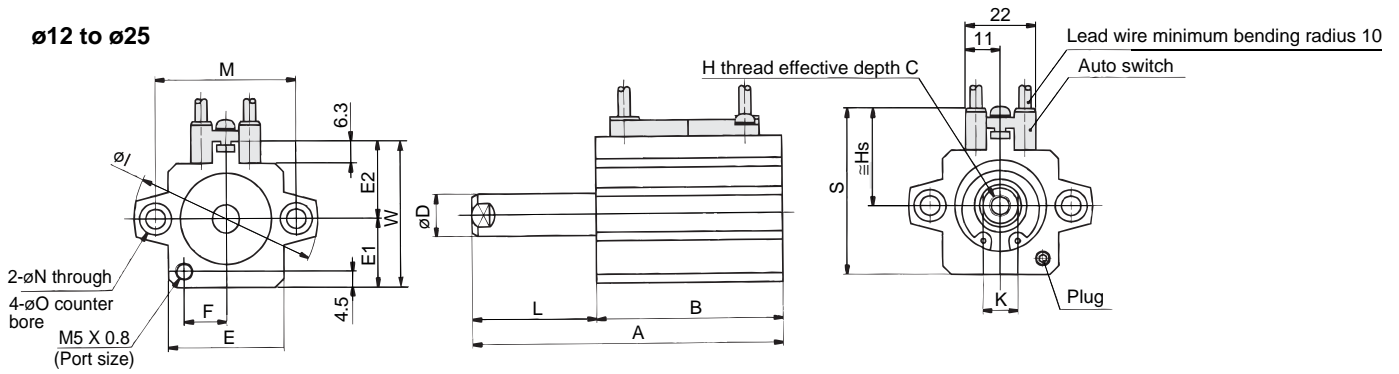

Above auto switch: D-A73/A80
Refer to p.2.3-95 for auto switch mounting position and mounting height.

Rod end male thread

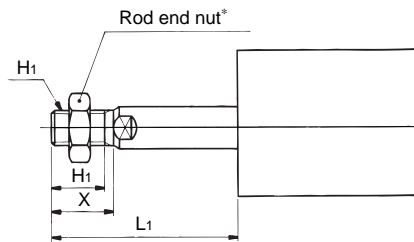

Rod end male thread (mm)

Bore (mm)	C1	X	H1	L1	
				5st	10st
12	9	10.5	M5 X 0.8	19	24
16	10	12	M6 X 1.0	20.5	25.5
20	12	14	M8 X 1.25	23.5	28.5
25	15	17.5	M10 X 1.25	27.5	32.5

Standard

Bore (mm)	A		B		C	D	E	E1	E2	F	H	I	K	L		M	N	O	S	U	W	
	5st	10st	5st	10st										5st	10st							
12	45.9	55.9	37.4	42.4	6	6	23	13	14	7	M3 X 0.5	32	5	8.5	13.5	22	3.5	6.5	Depth 3.5	32.5	19.5	27
16	44	54	35.5	40.5	8	8	26	15	17	8.5	M4 X 0.7	38	6	8.5	13.5	28	3.5	6.5	Depth 3.5	37.5	22.5	32
20	46	56	36.5	41.5	7	10	30	17	19	10.5	M5 X 0.8	47	8	9.5	14.5	36	5.5	9	Depth 7	41.5	24.5	36
25	47.5	57.5	37.5	42.5	12	12	33	19.5	22	12	M6 X 1.0	52	10	10	15	40	5.5	9	Depth 7	47	27.5	41.5

ø32 to ø50

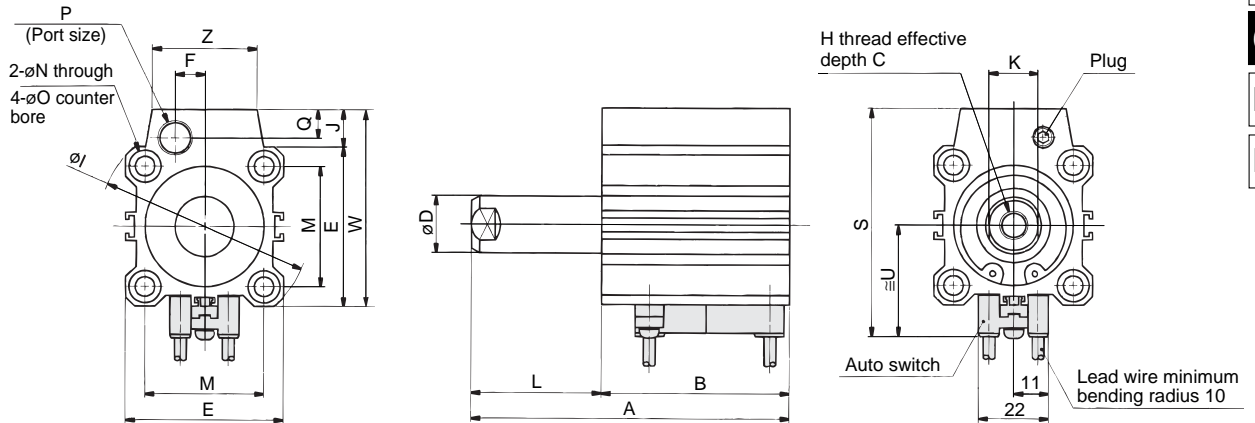

Above auto switch: D-A73/A80
Refer to p.2.3-95 for auto switch mounting position and mounting height.

Rod end male thread

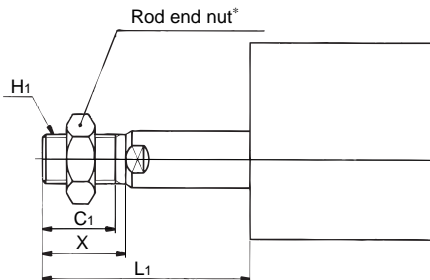

Rod end male thread (mm)

Bore (mm)	C1	X	H1	L1		
				5st	10st	20st
32	20.5	23.5	M14 X 1.5	33.5	38.5	-
40	20.5	23.5	M14 X 1.5	33.5	38.5	-
50	26	28.5	M18 X 1.5	-	43.5	53.5

Standard

Bore (mm)	A			B			C	D	E	F	H	I	J	K	L			M	N	O	P	Q	S	U	W	Z	
	5st	10st	20st	5st	10st	20st									5st	10st	20st										
32	50	60	-	38	43	-	13	16	45	8.5	M8 X 1.25	60	10.5	14	12	17	-	34	5.5	9	Depth 7	1/8	8	64.5	31.5	55.5	30
40	56.5	66.5	-	44.5	49.5	-	13	16	52	8.5	M8 X 1.25	69	10	14	12	17	-	40	5.5	9	Depth 7	1/8	8	71	35	62	30
50	-	68.5	88.5	-	50.5	60.5	15	20	64	11	M10 X 1.5	86	13	17	-	18	28	50	6.6	11	Depth 8	1/4	10	86	41	77	39

*Refer to p.2.3-18 & 19 for rod end nut and optional bracket.

Compact Cylinder/Large Bore Size: Double Acting Single Rod

Series CQ2

ø125, ø140, ø160

How to Order

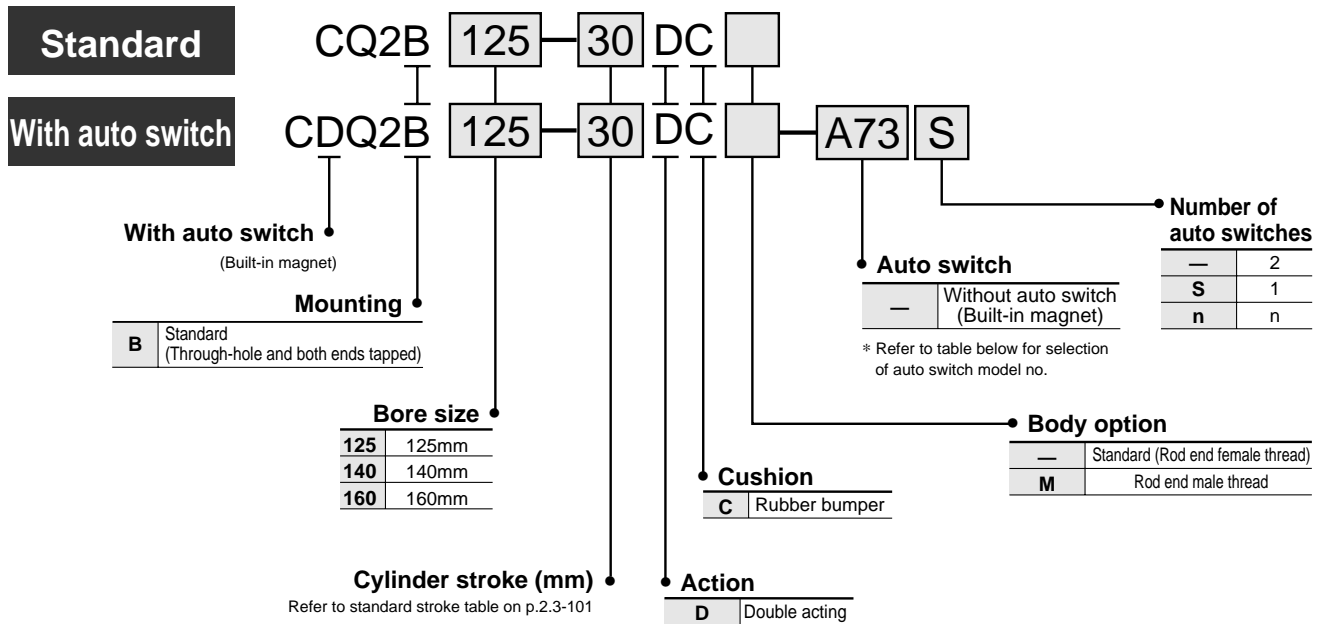

Applicable Auto Switches/Refer to p.5.3-2 for further information on auto switch.

Style	Special function	Electrical entry	Indicator	Wiring (Output)	Load voltage		Auto switch model		Lead wire* (m)				Applicable load								
					DC	AC	Perpendicular	In-line	0.5 (—)	3 (L)	5 (Z)	None (N)									
Reed switch	—	Grommet	Yes	3 wire (Equip.NPN)	—	5V	—	—	A76H	●	●	—	—	IC							
										—	200V	A72	A72H		●	●	—	—			
										24V	12V	100V	A73		A73H	●	●	—	—		
													—		—	●	●	—	—		
													5V, 12V		100V or less	A80	A80H	●	●	—	—
																A73C	—	●	●	●	●
5V, 12V	24V or less	A80C	—	●	●	●	●														
		A79W	—	●	●	—	—														
Solid state switch	—	Grommet	Yes	3 wire (NPN)	—	5V, 12V	—	—	F7NV	F79	●	●	○	—	IC						
									F7PV	F7P	●	●	○	—							
									Connector	2 wire	12V	F7BV	J79	●		●	○	—			
		J79C										—	●	●		●	●				
		F7NWV										F79W	●	●		○	—				
		Diagnostic (2 colour)							Grommet	Yes	3 wire (NPN)	—	5V, 12V	—		—	—	F7PW	●	●	○
	2 wire		12V	F7BWV	J79W	●	●	○							—						
				—	F7BA	—	●	○							—						
	Water resistance (2 colour)	Grommet	Yes	3 wire (PNP)	—	5V, 12V	—	—	—	F7NT	—	●	○	—	IC						
									2 wire	12V	—	F79F	●	●		○	—				
											4 wire (NPN)	—	F7LF	●		●	○	—			

* Lead wire length 0.5m — (Example) A80C 5m Z (Example) A80CZ
3m L (Example) A80CL None N (Example) A80CN

* Solid state switch marked with a "O" are manufactured upon receipt of order.

Compact Cylinder/Large Bore Size: Double Acting Single Rod *Series CQ2*



Style

Bore size (mm)		125	140	160	
Pneumatic	Mounting	Through-hole, Both ends tapped	●	●	●
	Built-in magnet		●	●	●
	Piping	Screw-in	Rc(PT)3/8	Rc(PT)3/8	Rc(PT)3/8
	Rod end male thread		●	●	●
	Rubber bumper (Standard)		●	●	●

Specifications

Style	Pneumatic (Non-lube)
Fluid	Air
Proof pressure	1.5MPa
Max. operating pressure	1.0MPa
Min. operating pressure	0.05MPa
Ambient and fluid temperature	Without auto switch: -10°C to 70°C (No freezing)
	With auto switch: -10°C to 60°C (No freezing)
Cushion	Rubber bumper (Standard)
Rod end thread	Female thread
Rod end thread tolerance	JIS class 2
Stroke length tolerance	+1.4 0
Mounting	Though-hole and both ends tapped
Piston speed	50 to 500mm/s

JIS symbol

Double acting: Single rod

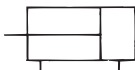

Standard Stroke

Bore size (mm)	Standard stroke (mm)
125, 140, 160	10, 20, 30, 40, 50, 75, 100, 125, 150, 175, 200, 250, 300

• Intermediate stroke
Intermediate strokes at 5mm intervals are available by using spacers with standard stroke cylinders.
Example) CQ2B125-160DC: Standard stroke cylinder
CQ2B125-175DC with 15mm width spacer inside.

Theoretical Force

Bore size (mm)	Operating direction	Operating pressure (MPa)		
		0.3	0.5	0.7
125	IN	3376	5626	7877
	OUT	3681	6135	8590
140	IN	4312	7187	10063
	OUT	4618	7696	10775
160	IN	5654	9424	13194
	OUT	6031	10053	14074

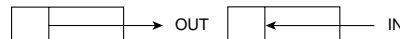

Unit: N

Weight

Without auto switch

Unit: kg

Bore size (mm)	Cylinder stroke (mm)												
	10	20	30	40	50	75	100	125	150	175	200	250	300
125	5.48	5.74	6.00	6.26	6.52	7.17	7.81	8.46	9.11	9.76	10.41	11.71	13.01
140	6.49	6.78	7.08	7.38	7.68	8.42	9.17	9.91	10.66	11.40	12.15	13.64	15.13
160	8.96	9.31	9.67	10.03	10.39	11.29	12.19	13.09	13.99	14.89	15.79	17.59	19.38

Built-in magnet

Unit: kg

Bore size (mm)	Cylinder stroke (mm)												
	10	20	30	40	50	75	100	125	150	175	200	250	300
125	5.54	5.80	6.06	6.32	6.58	7.23	7.87	8.52	9.17	9.82	10.47	11.77	13.07
140	6.56	6.85	7.15	7.45	7.75	8.49	9.24	9.98	10.73	11.47	12.22	13.71	15.20
160	9.04	9.39	9.75	10.11	10.47	11.37	12.27	13.17	14.07	14.97	15.87	17.67	19.46

CQ2 Large bore size/Minimum Strokes for Auto Switch Mounting

Unit: mm

Number of auto switches	D-F7□V D-J79C D-F7□ D-J79	D-A7□/D-A80 D-A73C/D-A80C D-A7□H D-A80H	D-F7□WV D-F7□W/D-J79W D-F7BAL D-F7NTL/D-F7LF	D-A79W
1 pc.	5	5	10	15
2 pcs.	5	10	15	20

⚠ Precautions

Be sure to read before handling.
Refer to p.0-39 to 0-46 for Safety Instructions and common precautions.

⚠ Caution

Snap Ring Installation/Removal

- For installation and removal, use an appropriate pair of pliers (tool for installing a C snap ring), because of the possibility of the snap ring becoming detached from the tip of the pliers (tool for installing a C snap ring) and flying away, which could injure humans or damage the peripheral equipment. After installing the snap ring, make sure that it is placed securely in the ring groove before supplying air.
- Exercise caution even when using an appropriate pair of pliers (tool for installing a C snap ring), because of the possibility of the snap ring becoming detached from the tip of the pliers (tool for installing a C snap ring) and flying away, which could injure humans or damage the peripheral equipment. After installing the snap ring, make sure that it is placed securely in the ring groove before supplying air.

Series CQ2

Option Weights

Unit: kg

Bore size (mm)		125	140	160
Rod end male thread	Male thread	0.31	0.31	0.48
	Nut	0.16	0.16	0.26

Calculation example: CDQ2B125-30DCM

- Basic weight: CDQ2B125-30DC.....6.06kg
- Additional weight: Rod end male thread.....0.47kg

6.53kg

Add the weight of auto switches and mounting brackets.

Weight/Auto Switch Mounting Bracket

Part No.	Bore size	Weight (g)
BQ-2	ø125 to ø160	1.5

Refer to p.5.3-75 for auto switch specifications

Mounting Bolt for CQ2

Special bolt for through-hole of CQ2B is available as option.

How to Order: Specify the required bolts.

Example) Bolt M12 X 100 ℓ 4 pcs.

Note 1) To install a through hole type mounting bolt, make sure to use the flat washer that is provided.

Note 2) Consult SMC regarding mounting bolts for strokes that exceed 100mm. Use the OA screw provided on the cylinder tube to secure the cylinder.

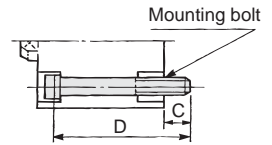

Model	C	D	Mounting bolt	Model	C	D	Mounting bolt
C□Q2B125, 140-10DC		100	M12 X 100 ℓ	C□Q2B160-10DC	110	110	M14 X 110 ℓ
-20DC		110	X 110 ℓ	-20DC	120	120	X 120 ℓ
-30DC		120	X 120 ℓ	-30DC	130	130	X 130 ℓ
-40DC	22.9	130	X 130 ℓ	-40DC	140	140	X 140 ℓ
-50DC		140	X 140 ℓ	-50DC	150	150	X 150 ℓ
-75DC		165	X 165 ℓ	-75DC	175	175	X 175 ℓ
-100DC		190	X 190 ℓ	-100DC	200	200	X 200 ℓ

Construction

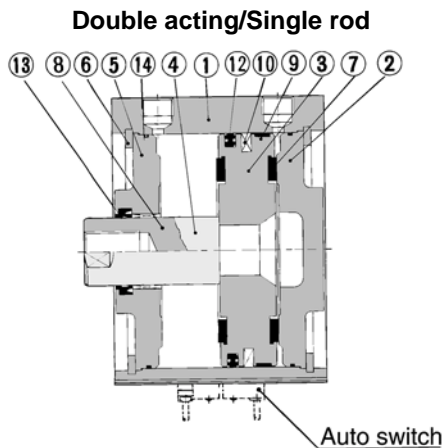

Rod end male thread

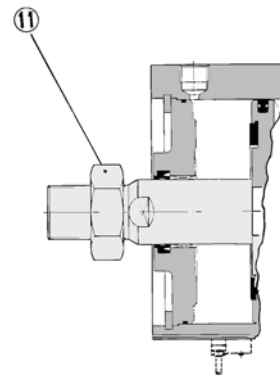

Component Parts

No.	Description	Material	Note
①	Cylinder tube	Aluminum alloy	Hard anodized
②	Head cover	Casting steel	Zinc chromated
③	Piston	Aluminum alloy casting	Chromated
④	Piston rod	Carbon steel	Hard chrome plated
⑤	Rod cover	Casting steel	Zinc chromated
⑥	Snap ring	Carbon tool steel	Phosphate coating
⑦	Bumper	Urethane	
⑧	Bushing	Lead bronze casting	
⑨	Wearing	Resin	
⑩	Magnet	—	For only CDQ2□B
⑪	Rod end nut	Rolled steel	Nickel plated
⑫	Piston seal	NBR	
⑬	Rod seal	NBR	
⑭	Tube gasket	NBR	

Replacement Parts: Seal Kits

Bore size (mm)	Kit No.	Note
125	CQ2B125-PS	A set includes ⑫, ⑬ and ⑭
140	CQ2B140-PS	
160	CQ2B160-PS	

* Seal kits are sets consisting of items ⑫, ⑬ and ⑭, which can be ordered using the kit number for each cylinder bore size.

Auto Switch Mounting Bracket Part No.

Bore size (mm)	Part No.	Note	Applicable switch	
			Reed switch	Solid state switch
125 140 160	BQ-2	<ul style="list-style-type: none"> • Switch mounting screw (M3 X 0.5 X 10 ℓ) • Switch interface • Switch mounting nut 	D-A7□, A80 D-A73C, A80C D-A7□H, A80H D-A79W	D-F7□, J79 D-F7□V D-J79C D-F7□W, J79W D-F7□WV D-F7BAL D-F7□F, D-F7NTL

[Stainless steel mounting bolt set]

The set of stainless steel mounting screws (with nut) described below is available and can be used depending on the operating environment. (The spacer for auto switches must be ordered separately, as they are not included.)

BBA2: For D-A7/A8/F7/J7

The stainless steel bolts described above are used when the D-F7BAL type switch is shipped mounted on a cylinder. When the switches are shipped as individual parts, the BBA2 set is included.

Rod End Nut

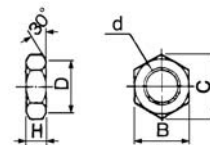

Material: Rolled steel

Part No.	Bore size (mm)	d	H	B	C	D
NT-12	125/140	M30 X 1.5	18	46	53.1	44
NT-16	160	M36 X 1.5	21	55	63.5	53

Compact Cylinder/Large Bore Size: Double Acting Single Rod **Series CQ2**

Bore size

ø125, ø140, ø160

Standard (Through-hole)/C□Q2B

The outer dimensions are the same with or without an auto switch.

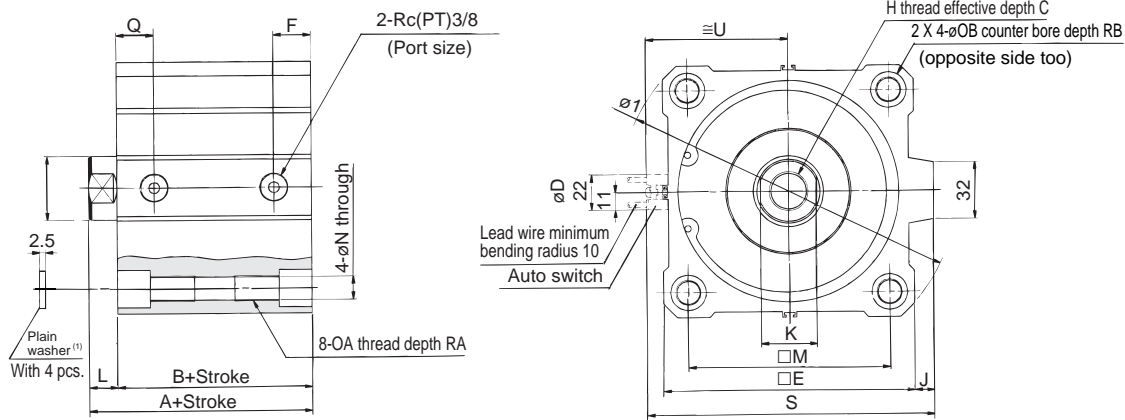

Rod end male thread

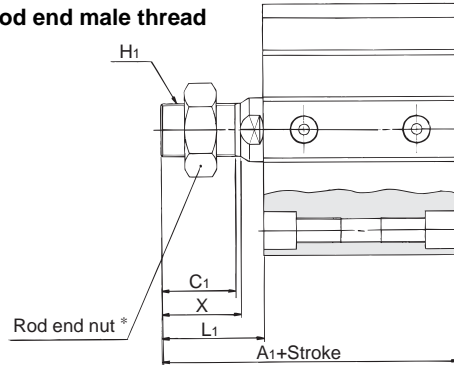

Rod end male thread

Bore (mm)	A1	C1	H1	L1	X
125	141	42	M30 X 1.5	58	45
140	141	42	M30 X 1.5	58	45
160	155	47	M36 X 1.5	64	50



Above switch: D-A73/A80 Refer to below for auto switch mounting position and mounting height.

Bore	Standard stroke range	A	B	C	D	E	F	H	I	J	K	L	M	N	OA	OB	Q	RA	RB	S	U
125	10, 20, 30, 40, 50	99	83	30	36	142	24.5	M22 X 2.5	190	11	32	16	114	12.5	M14 X 2	21.2	24.5	25	18.4	162	80
140	75, 100, 125, 150	99	83	30	36	158	24.5	M22 X 2.5	210	10	32	16	128	12.5	M14 X 2	21.2	24.5	25	18.4	177	88
160	175, 200, 250, 300	108	91	33	40	178	27.5	M24 X 3	238	10	36	17	144	14.5	M16 X 2	24.2	27.5	28	21.2	197	98

Note 1) Attached plain washer must be used for through-hole mounting.

CUJ

CU

CQS

CQ2

RQ

MU

Auto Switch Mounting Position (at Stroke End) and Mounting Height

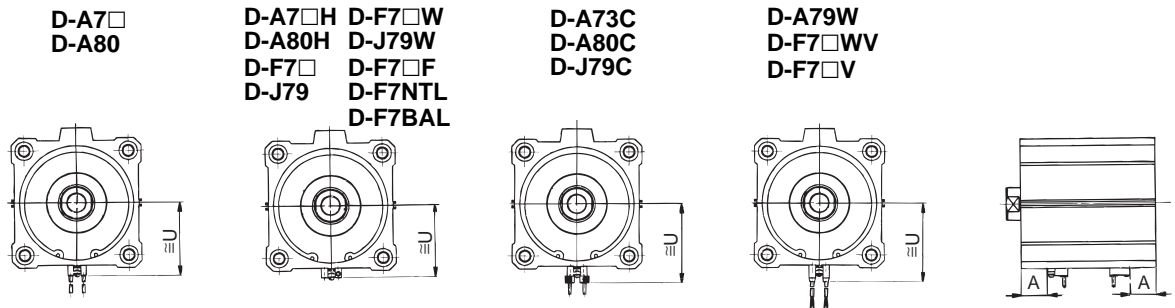

Auto Switch Setting Position

Bore size (mm)	D-A7□ D-A80	A7□H, A80H, D-A73C, A80C D-F7□, F7□V D-J79C, J79	D-A79W	D-F7NTL	D-F7□W D-J79W D-F79F-D-F7LF D-F7BAL D-F7□WV
	A	A	A	A	A
125	32.5	33	30	38	37
140	32.5	33	30	38	37
160	36.5	37	34	42	41

Auto Switch Mounting Height

D-A7□ D-A80	D-A7□H, D-A80H D-F7□, D-J79, D-F7□W D-J79W, D-F7BAL D-F7□F, D-F7NTL	D-A73C D-A80C	D-F7□V D-F7□WV	D-J79C	D-A79W
U	U	U	U	U	U
80	81	87	83.5	85.5	82.5
88	89	95	91.5	93.5	90.5
98	99	105	101.5	103.5	100.5

Compact Cylinder/Large Bore Size: Double Acting Double Rod

Series CQ2W

ø125, ø140, ø160

How to Order

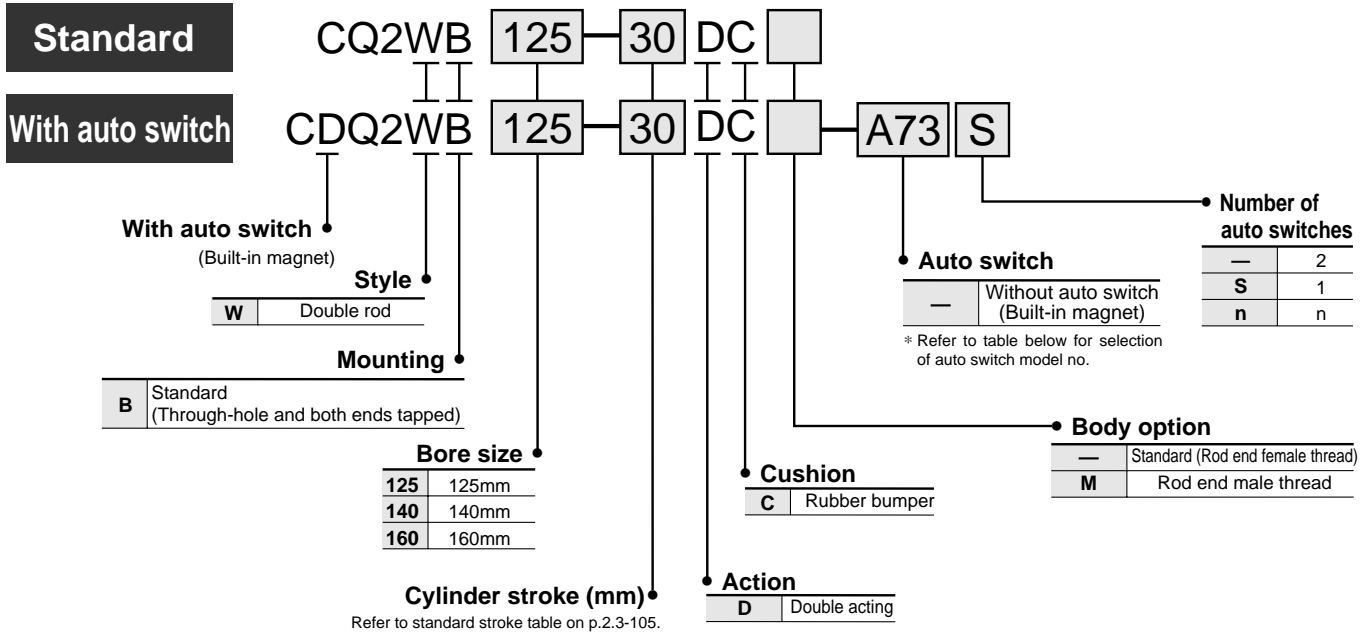

Applicable Auto Switches/Refer to p.5.3-2 for further information on auto switch.

Style	Special function	Electrical entry	Indicator	Wiring (Output)	Load voltage		Auto switch model		Lead wire* (m)				Applicable load										
					DC	AC	Perpendicular	In-line	0.5 (Nil)	3 (L)	5 (Z)	None (N)											
Reed switch	—	Grommet	Yes	3 wire (Equiv. NPN)	—	5V	—	—	A76H	●	●	—	—	IC									
										24V	12V	100V	A72		A72H	●	●	—	—				
													A73		A73H	●	●	●	—				
										Connector	No	24V	12V		—	—	—	—	—	—	—	—	—
										Connector	Yes	24V	12V		—	—	—	—	—	—	—	—	—
A73C	—	●	●	●	●	IC																	
Diagnostic (2 colour)	—	Grommet	Yes	—	—		—	—	—	—	—	—	—	—									
Solid state switch	—	Grommet	Yes	3 wire (NPN)	—	5V, 12V	—	—	F7NV	F79	●	●	○	—	IC								
				3 wire (PNP)					F7PV	F7P	●	●	○	—									
		Connector	No	24V	12V	—	—	—	—	—	—	—	—	—	—								
																F7BV	J79	●	●	○	—		
		Diagnostic (2 colour)	—	Grommet	Yes	3 wire (NPN)	—	5V, 12V	—	—	—	—	—	—	—	—							
						3 wire (PNP)											F7NWV	F79W	●	●	○	—	IC
		Water resistance (2 colour)	—	Grommet	Yes	2 wire	—	12V	—	—	—	—	—	—	—	—							
						F7BWV											J79W	●	●	○	—	Relay, PLC	
		With timer	—	Grommet	Yes	2 wire	—	12V	—	—	—	—	—	—	—	—							
						—											F7BA	●	●	○	—		
Diagnostic output (2 colour)	—	Grommet	Yes	3 wire (NPN)	—	5V, 12V	—	—	—	—	—	—	—	—									
				—											F7NT	—	●	○	—	IC			
Latch with diagnostic output (2 colour)	—	Grommet	Yes	3 wire (PNP)	—	5V, 12V	—	—	—	—	—	—	—	—									
				—											F79F	●	●	○	—				
Diagnostic output (2 colour)	—	Grommet	Yes	4 wire (NPN)	—	—	—	—	—	—	—	—	—	—									
				—											F7LF	●	●	○	—				

* Lead wire length 0.5m — (Example) A80C 5m Z (Example) A80CZ
3m L (Example) A80CL None N (Example) A80CN

* Solid state switches marked with a "O" are manufactured upon receipt of order.

Compact Cylinder/Large Bore Size: Double Acting Double Rod *Series CQ2W*

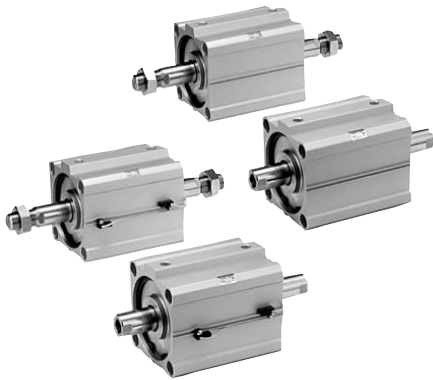

Style

Bore size (mm)		125	140	160
Pneumatic	Mounting	Through-hole, both ends tapped (Common)		
	Built-in magnet	●	●	●
	Piping	Screw-in		
	Rod end male thread	●	●	●
	Rubber bumper (Standard)	●	●	●

Specifications

Style	Pneumatic (non-lube)
Fluid	Air
Proof pressure	1.5MPa
Max. operating pressure	1.0MPa
Min. operating pressure	0.05MPa
Ambient and fluid temperature	Without auto switch: -10°C to 70°C (No freezing)
	With auto switch: -10°C to 60°C (No freezing)
Cushion	Rubber bumper (Standard)
Rod end thread	Female thread
Rod end thread tolerance	JIS class 2
Stroke length tolerance	+1.4 0
Mounting	Through-hole, both ends tapped (Common)
Piston speed	50 to 500mm/s

JIS symbol

Double acting/Double rod

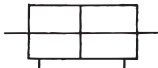

Standard Stroke

Bore size (mm)	Standard stroke (mm)
125, 140, 160	10, 20, 30, 40, 50, 75, 100, 125, 150, 175, 200, 250, 300

Theoretical Force

Unit: N

Bore size (mm)	Operating pressure (MPa)		
	0.3	0.5	0.7
125	3376	5626	7877
140	4312	7187	10063
160	5654	9424	13194

⚠ Precautions

Be sure to read before handling. Refer to p.0-39 to 0-46 for Safety Instructions and common precautions.

⚠ Caution

Snap Ring Installation/Removal

- For installation and removal, use an appropriate pair of pliers (tool for installing a C snap ring).
- Exercise caution even when using an appropriate pair of pliers (tool for installing a C snap ring), because of the possibility of the snap ring becoming detached from the tip of the pliers (tool for installing a C snap ring) and flying away, which could injure humans or damage the peripheral equipment. After installing the snap ring, make sure that it is placed securely in the ring groove before supplying air.

Mounting

- When removing a load, be sure to secure the wrench flats of the piston rod on the load side.
- If this is done without securing the piston rod on the load side, be aware that the coupled (screw-in) portion of the piston rod could become loosened.

Weight

Without Auto Switch

Unit: kg

Bore size (mm)	Cylinder stroke (mm)												
	10	20	30	40	50	75	100	125	150	175	200	250	300
125	5.71	6.02	6.34	6.68	7.02	7.87	8.71	9.56	10.41	11.26	12.11	13.81	15.50
140	6.73	7.07	7.43	7.80	8.18	9.13	10.07	11.01	11.96	12.90	13.84	15.73	17.62
160	9.26	9.69	10.12	10.58	11.04	12.18	13.33	14.47	15.62	16.76	17.91	20.20	22.49

Built-in Magnet

Unit: kg

Bore size (mm)	Cylinder stroke (mm)												
	10	20	30	40	50	75	100	125	150	175	200	250	300
125	5.77	6.08	6.40	6.74	7.08	7.93	8.77	9.62	10.47	11.32	12.17	13.87	15.56
140	6.80	7.14	7.50	7.87	8.25	9.20	10.14	11.08	12.03	12.97	13.91	15.80	17.69
160	9.34	9.77	10.20	10.66	11.12	12.26	13.41	14.55	15.70	16.84	17.99	20.28	22.57

CQ2 Large Bore Size/Minimum strokes for auto switch mounting

Unit: mm

Number of auto switches	D-F7□V D-J79C D-F7□ D-J79	D-A7□, D-A80 D-A73C, D-A80C D-A7□H D-A80H	D-F7□WV D-F7□W, D-J79W D-F7BAL D-F7NTL, D-F7LF	D-A79W
1	5	5	10	15
2	5	10	15	20

Series CQ2W

Option Weights

Unit: kg

Bore size (mm)		125	140	160
Rod end male thread	Male thread area	0.62	0.62	0.96
	Nut	0.32	0.32	0.52

Calculation example: CDQ2WB125-30DCM

- Basic weight: CDQ2WB125-30DC..... 6.40kg
- Additional weight: Rod end male thread..... 0.94kg
- 7.34kg

Add the weight of auto switches and mounting brackets.

Weight/Auto Switch Mounting Bracket

Part no.	Bore size	Weight (g)
BQ-2	ø125 to ø160	1.5

Refer to p.5.3-75 for auto switch specifications

Mounting Bolt for CQ2

Special bolt for through-hole mounting of CQ2WB is available as option.
How to Order: Specify the required bolts.

Example) Bolt M12 X 100 ℓ 4 pcs.

Note 1) To install a through hole type mounting bolt, make sure to use the flat washer that is provided.

Note 2) Consult SMC regarding mounting bolts for strokes that exceed 100mm.
Use the OA screw provided on the cylinder tube to secure the cylinder.

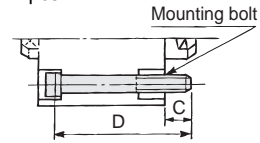

Model	C	D	Mounting bolt	Model	C	D	Mounting bolt
C□Q2WB125, 140-10DC		100	M12 X 100 ℓ	C□Q2WB160-10DC		110	M14 X 110 ℓ
C□Q2WB125, 140-20DC		110	M12 X 110 ℓ	C□Q2WB160-20DC		120	M14 X 120 ℓ
C□Q2WB125, 140-30DC		120	M12 X 120 ℓ	C□Q2WB160-30DC		130	M14 X 130 ℓ
C□Q2WB125, 140-40DC	22.9	130	M12 X 130 ℓ	C□Q2WB160-40DC	27.7	140	M14 X 140 ℓ
C□Q2WB125, 140-50DC		140	M12 X 140 ℓ	C□Q2WB160-50DC		150	M14 X 150 ℓ
C□Q2WB125, 140-75DC		165	M12 X 165 ℓ	C□Q2WB160-75DC		175	M14 X 175 ℓ
C□Q2WB125, 140-100DC		190	M12 X 190 ℓ	C□Q2WB160-100DC		200	M14 X 200 ℓ

Construction

Double acting/Double rod

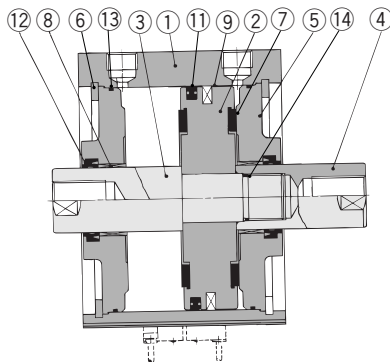

Rod end male thread

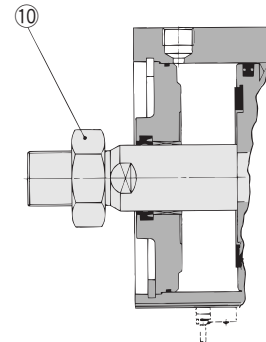

Component Parts

No.	Description	Material	Note
①	Cylinder tube	Aluminum alloy	Hard anodized
②	Piston	Aluminum alloy casting	Chromated
③	Piston rod A	Carbon steel	Hard chrome plated
④	Piston rod B	Carbon steel	Hard chrome plated
⑤	Rod cover	Casting	Zinc chromated
⑥	Snap ring	Carbon tool steel	Phosphate coating
⑦	Bumper	Resin	
⑧	Bushing	Lead bronze casting	
⑨	Magnet	—	For only CDQ□B
⑩	Rod end nut	Rolled steel	Nickel plated
⑪	Piston seal	NBR	
⑫	Rod seal	NBR	
⑬	Tube gasket	NBR	
⑭	Piston gasket	NBR	

Replacement Parts: Seal Kits

Bore size (mm)	Kit No.	Note
125	CQ2WB125-PS	A set includes ⑪, ⑫ and ⑬.
140	CQ2WB140-PS	
160	CQ2WB160-PS	

* Seal kits are sets consisting of items ⑪, ⑫ and ⑬, which can be ordered using the order number for each cylinder bore size.

Auto Switch Mounting Bracket Part No.

Bore size (mm)	Part No.	Note	Applicable switch	
			Reed switch	Solid state switch
125 140 160	BQ-2	<ul style="list-style-type: none"> • Switch mounting screw (M3 X 0.5 X 10 ℓ) • Switch interface • Switch mounting nut 	D-A7□, A80 D-A73C, A80C D-A7□H, A80H D-A79W	D-F7□, J79 D-F7□V D-J79C D-F7□W, J79W D-F7□WV D-F7BAL D-F7□F, D-F7NTL



*Stainless steel mounting bolt set

The set of stainless steel mounting screws (with nut) described below is available and can be used depending on the operating environment. (The spacer for auto switches must be ordered separately, as they are not included.)

BBA2: For D-A7/A8/F7/J7

The stainless steel bolts described above are used when the D-F7BAL switch is shipped mounted on a cylinder. When the switches are shipped as individual parts, the BBA2 set is included.

Rod End Nut

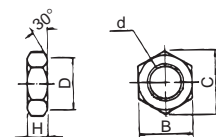

Material: Rolled steel

No.	Bore size (mm)	d	H	B	C	D
NT-12	125/140	M30 X 1.5	18	46	53.1	44
NT-16	160	M36 X 1.5	21	55	63.5	53

Compact Cylinder/Large Bore Size: Double Acting Double Rod **Series CQ2W**

ø125, ø140, ø160

Standard (Through-hole)/C□Q2WB

The dimensions are the same with or without an auto switch.

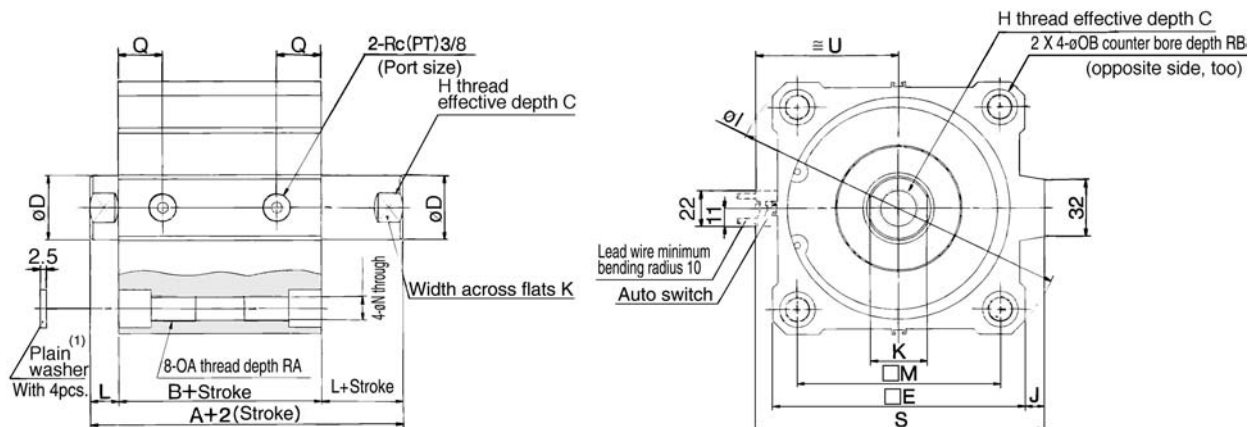

Rod end male thread

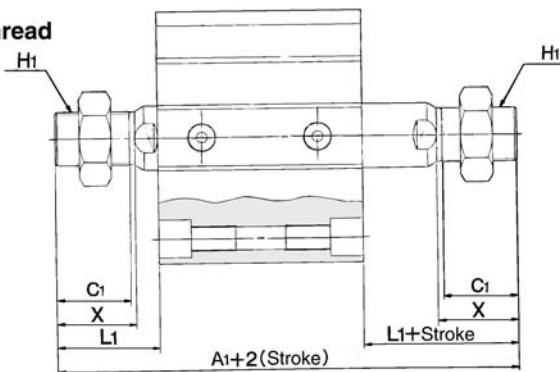

Rod end male thread

Bore (mm)	A1	C1	H1	L1	X
125	199	42	M30 X 1.5	58	45
140	199	42	M30 X 1.5	58	45
160	219	47	M36 X 1.5	64	50



Above auto switch: D-A73/A80 Refer to below for auto switch setting position and mounting height.

Bore (mm)	Standard stroke range	A	B	C ⁽²⁾	D	E	H	I	J	K	L	M	N	OA	OB	Q	RA	RB	S	U
125	10, 20, 30, 40, 50	115	83	30(22.5)	36	142	M22 X 2.5	190	11	32	16	114	12.5	M14 X 2	21.2	24.5	25	18.4	162	80
140	75, 100, 125, 150	115	83	30(22.5)	36	158	M22 X 2.5	210	10	32	16	128	12.5	M14 X 2	21.2	24.5	25	18.4	177	88
160	175, 200, 250, 300	125	91	33(26.5)	40	178	M24 X 3	238	10	36	17	144	14.5	M16 X 2	24.2	27.5	28	21.2	197	98

Note 1) Attached plain washer must be used for through-hole mounting.

Note 2) The values in parentheses indicate the effective length of one side, only for the 10 stroke type.

Auto Switch Mounting Position (at Stroke End) and Mounting Height

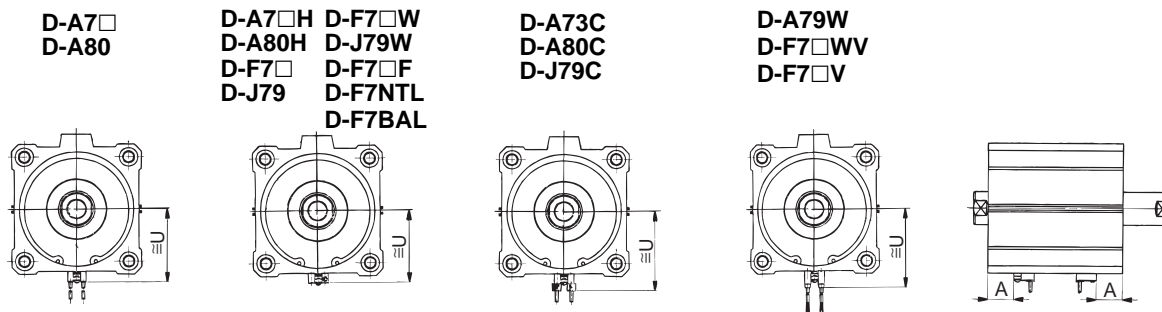

Auto Switch Mounting Position

Bore size (mm)	D-A7□ D-A80	A7□H, A80H, D-A73C, A80C D-F7□, F7□V D-J79C, J79	D-A79W	D-F7NTL	D-F7□W D-J79W D-F79F, D-F7LF D-F7BAL D-F7□WV
	A	A	A	A	A
125	32.5	33	30	38	37
140	32.5	33	30	38	37
160	36.5	37	34	42	41

Auto Switch Mounting Height

D-A7□ D-A80	D-A7□H, D-A80H D-F7□, D-J79, D-F7□W D-J79W, D-F7BAL D-F7□F, D-F7NTL	D-A73C D-A80C	D-F7□V D-F7□WV	D-J79C	D-A79W
U	U	U	U	U	U
80	81	87	83.5	85.5	82.5
88	89	95	91.5	93.5	90.5
98	99	105	101.5	103.5	100.5

CUJ
CU
CQS
CQ2
RQ
MU

Large Bore Compact Cylinder ø180, ø200

Series CQ2

ø180 and ø200 added to CQ2 compact cylinder series.

Large bore sizes

ø180 and ø200

Compact and light weight

Substantial reductions in dimensions and weight compared to tie-rod type cylinders



Auto switches

- No protrusion from cylinder body
- Can be mounted on four sides

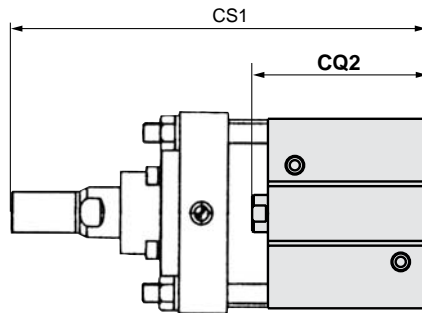

Series		Overall length mm	Weight kg
CQ2	ø180	219	16.6
	ø200	226	20.6
CS1	ø180	385	30.4
	ø200	390	39.5

Comparison with 100mm stroke and rod end male threads

Variations

Series	Action	Type	Size	Standard strokes	Rod end configuration	Applicable auto switch models
CQ2	Double acting	Single rod	180	10 20 30 40 50 75 100 125 150 175 200 250 300	Female threads Male threads	Reed switches: D-Z7, Z8 Solid state switches: D-Y5, Y6, Y7
		Double rod	200			

Compact cylinder variations

A wide range of 15 sizes from ø12 to ø200

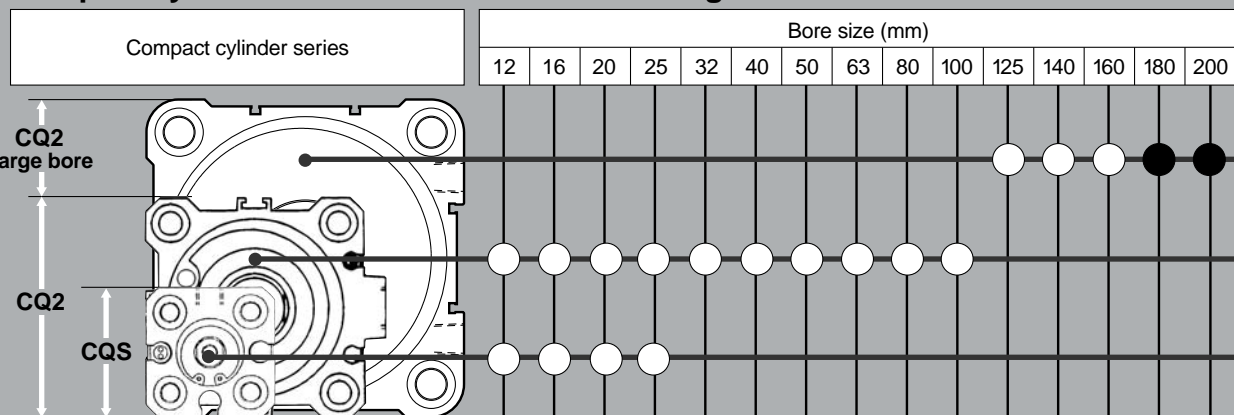

Compact Cylinder/Double Acting: Single Rod

Series CQ2

ø180, ø200

How to Order

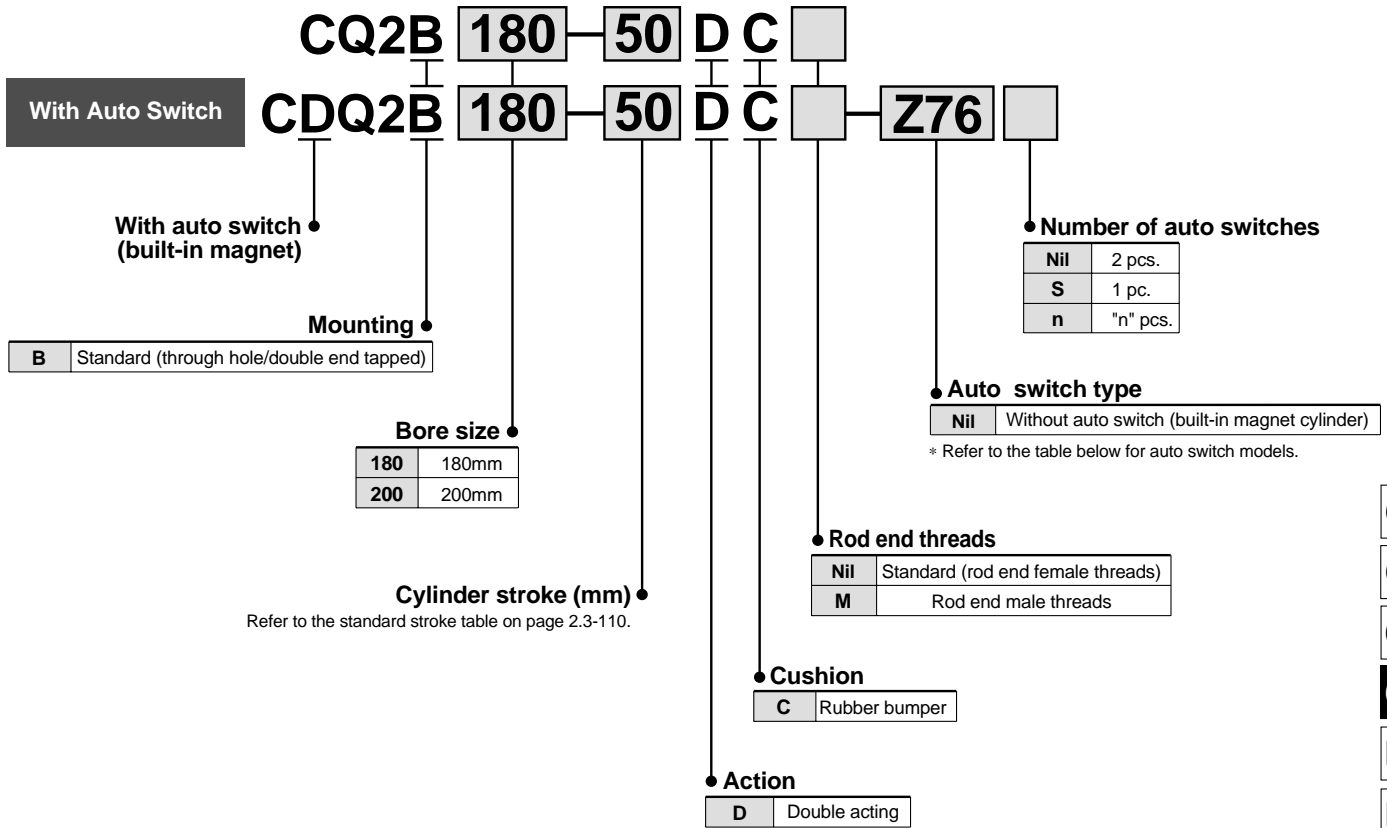

Applicable Auto Switches/Refer to p.5.3-2 for further information on auto switch.

Type	Special function	Electrical entry	Indicator light	Wiring (output)	Load voltage		Auto switch models		*Lead wire length (mm)			Applicable loads		
					DC	AC	Electrical entry direction	Perpendicular	In-line	0.5 (Nil)	3 (L)	5 (Z)	IC circuit	Relay, PLC
Reed switch	-	Grommet	Yes	3 wire	-	5V	-	-	Z76	●	●	-	IC circuit	-
				2 wire	24V	12V	100V	-	Z73	●	●	●	-	Relay, PLC
			No	2 wire	24V	5V, 12V	100V or less	-	Z80	●	●	-	IC circuit	-
Solid state switch	-	Grommet	Yes	3 wire (NPN)	24V	5V, 12V	-	Y69A	Y59A	●	●	○	IC circuit	Relay, PLC
				3 wire (PNP)				Y7PV	Y7P	●	●	○	IC circuit	
				2 wire				Y69B	Y59B	●	●	○	-	
				3 wire (NPN)				Y7NWV	Y7NW	●	●	○	IC circuit	
				3 wire (PNP)				Y7PWV	Y7PW	●	●	○	-	
				2 wire				Y7BWV	Y7BW	●	●	○	-	
				Water resistant (2 colour indicator)				-	Y7BA	-	●	○	-	

* Lead wire length symbols: 0.5m Nil (Example) Y69B
 3m L Y69BL
 5m Z Y69BZ

** Auto switches marked with a "○" symbol are produced upon receipt of order.

Series CQ2



Specifications

Fluid	Air
Proof pressure	1.05MPa
Maximum operating pressure	0.7MPa
Minimum operating pressure	0.05MPa
Ambient and fluid temperature	Without auto switch: -10°C to 70°C (with no freezing)
	With auto switch: -10°C to 60°C (with no freezing)
Lubrication	Non-lube
Cushion	Rubber bumper
Rod end threads	Female threads
Thread tolerance	JIS class 2
Stroke length tolerance	+1.4 0
Mounting brackets	Basic type
Mounting	Through hole/Double end tapped

Symbol

Double acting: Single rod

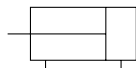

Standard Strokes

Bore size (mm)	Standard strokes (mm)
180, 200	10, 20, 30, 40, 50, 75, 100, 125, 150, 175, 200, 250, 300

- Manufacture of intermediate strokes
Intermediate strokes in 5mm increments can be manufactured by installing spacers inside standard stroke cylinders.
Example) CQ2B180-160DC is produced by installing a 15mm spacer in a standard stroke cylinder CQ2B180-175DC.

Minimum Strokes for Mounting of Auto Switches

Bore size (mm)	Mounting	D-Z7, Z8	D-Y5, Y6, Y7	DD-Y7□W, D-Y7BAL
		2 pcs. (different sides, same side)	10	5
180, 200	1 pc.	5	5	10

Theoretical Output/Double Acting Type



Unit: N

Bore size (mm)	Operating direction	Operating Pressure (MPa)					
		0.2	0.3	0.4	0.5	0.6	0.7
180	IN	4838	7257	9676	12095	14514	16933
	OUT	5089	7634	10179	12724	15268	17812
200	IN	6032	9048	12064	15080	18096	21112
	OUT	6283	9425	12566	15708	18850	21991

Do not apply loads greater than 50% of the theoretical output.

Weight Table

Unit: kg

Bore size (mm)	Standard strokes (mm)													With magnet	Rod end male threads
	10	20	30	40	50	75	100	125	150	175	200	250	300	Additional weight	Additional weight
180	11.97	12.39	12.81	13.24	13.67	14.73	15.80	16.87	17.93	18.99	20.05	22.18	24.31	0.08	0.74
200	15.30	15.87	16.35	16.84	17.33	18.55	19.77	20.99	22.21	23.43	24.74	27.08	29.52	0.09	0.74

Example) CDQ2B180-100DCM

Basic weight	CQ2B180-100DC	15.80kg
Additional weight	Built-in magnet	0.08kg
	Rod end male threads	0.74kg
		<u>Total 16.62kg</u>

Construction

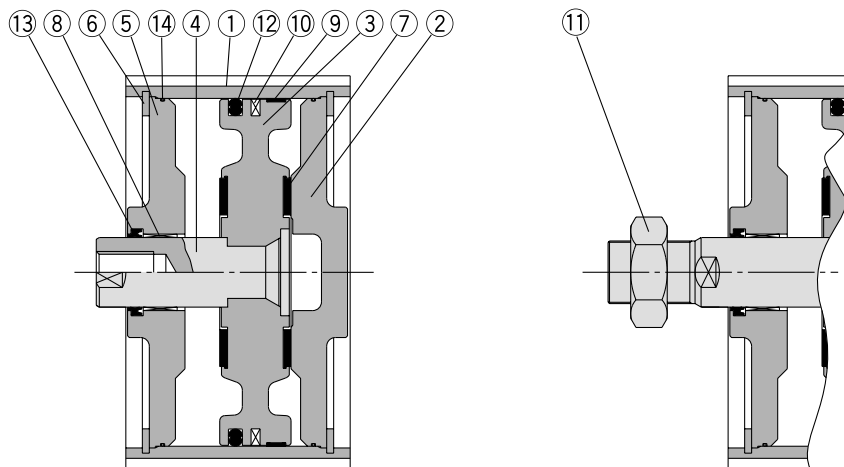

Rod end male threads

Parts list

No.	Description	Material	Note
1	Cylinder tube	Aluminum alloy	Hard anodized
2	Head cover	Cast iron	Nickel plated
3	Piston	Aluminum alloy casting	Chromated
4	Piston rod	Carbon steel	Hard chrome plated
5	Rod cover	Cast iron	Nickel plated
6	Snap ring	Carbon tool steel	Phosphate coated
7	Bumper	Polyurethane	
8	Bushing	Lead-bronze casting	
9	Wear ring	Resin	
10	Magnet	-	CDQ2B only

Parts list

No.	Description	Material	Note
11	Rod end nut	Rolled steel	Nickel plated
12	Piston seal	NBR	
13	Rod seal	NBR	
14	Tube gasket	NBR	

Replacement parts: Seal kits

Bore size (mm)	Seal kit No.	Contents
180	CQ2B180-PS	A set of Nos.12, 13 and 14 from the table above
200	CQ2B200-PS	

Mounting

Mounting/Through hole type mounting bolts are available.

How to order: Add "Bolt" in front of the bolts to be used.

(Example) Bolt M18 x 125 ℓ

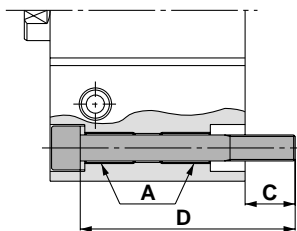

Note1) When mounting with through hole type mounting bolts, be sure to use the flat washers which are included.

Note 2) When mounting a cylinder with a stroke over 100mm, use the section A mounting threads.

Model	C	D	Mounting bolt
C (D) Q2B180- 10DC	36	125	M18 x 125 ℓ
C (D) Q2B180- 20DC		135	M18 x 135 ℓ
C (D) Q2B180- 30DC		145	M18 x 145 ℓ
C (D) Q2B180- 40DC		155	M18 x 155 ℓ
C (D) Q2B180- 50DC		165	M18 x 165 ℓ
C (D) Q2B180- 75DC		190	M18 x 190 ℓ
C (D) Q2B180-100DC		215	M18 x 215 ℓ

Model	C	D	Mounting bolt
C (D) Q2B200- 10DC	39	135	M18 x 135 ℓ
C (D) Q2B200- 20DC		145	M18 x 145 ℓ
C (D) Q2B200- 30DC		155	M18 x 155 ℓ
C (D) Q2B200- 40DC		165	M18 x 165 ℓ
C (D) Q2B200- 50DC		175	M18 x 175 ℓ
C (D) Q2B200- 75DC		200	M18 x 200 ℓ
C (D) Q2B200-100DC		225	M18 x 225 ℓ

CUJ
CU
CQS
CQ2
RQ
MU

Series CQ2

Dimensions

Dimensions are the same with and without auto switches.

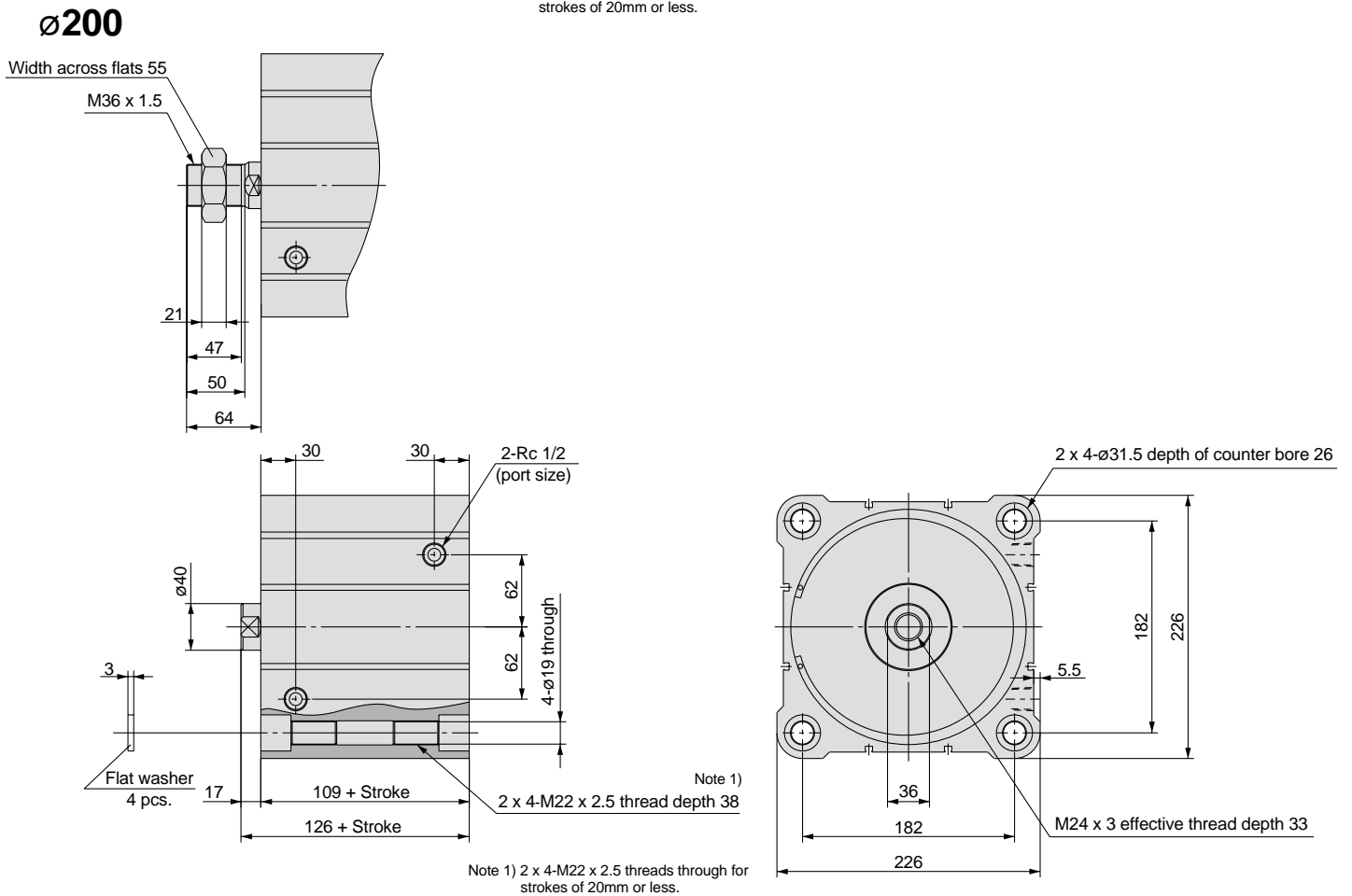
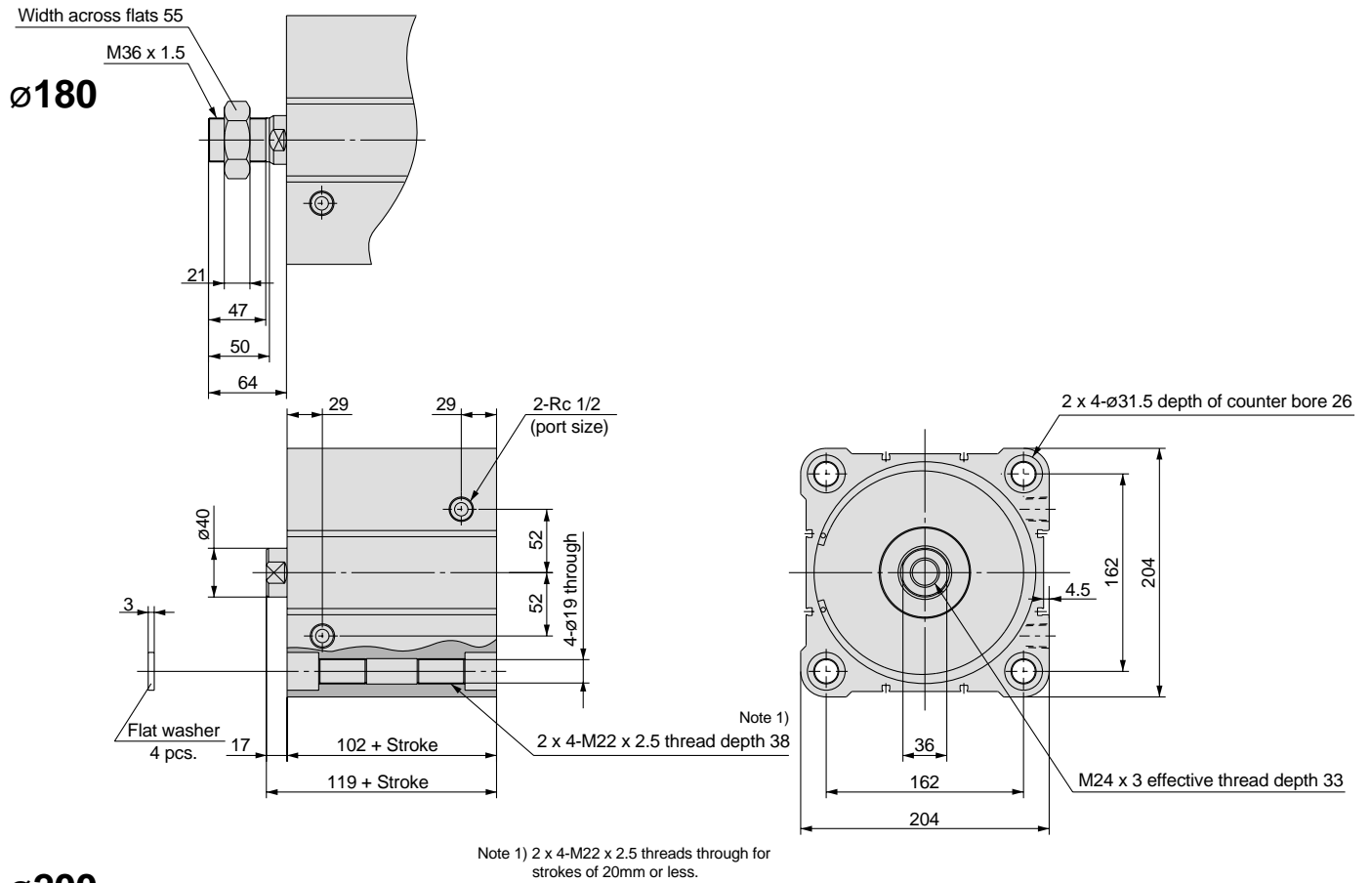

Compact Cylinder/Double Acting: Double Rod

Series CQ2W

ø180, ø200

How to Order

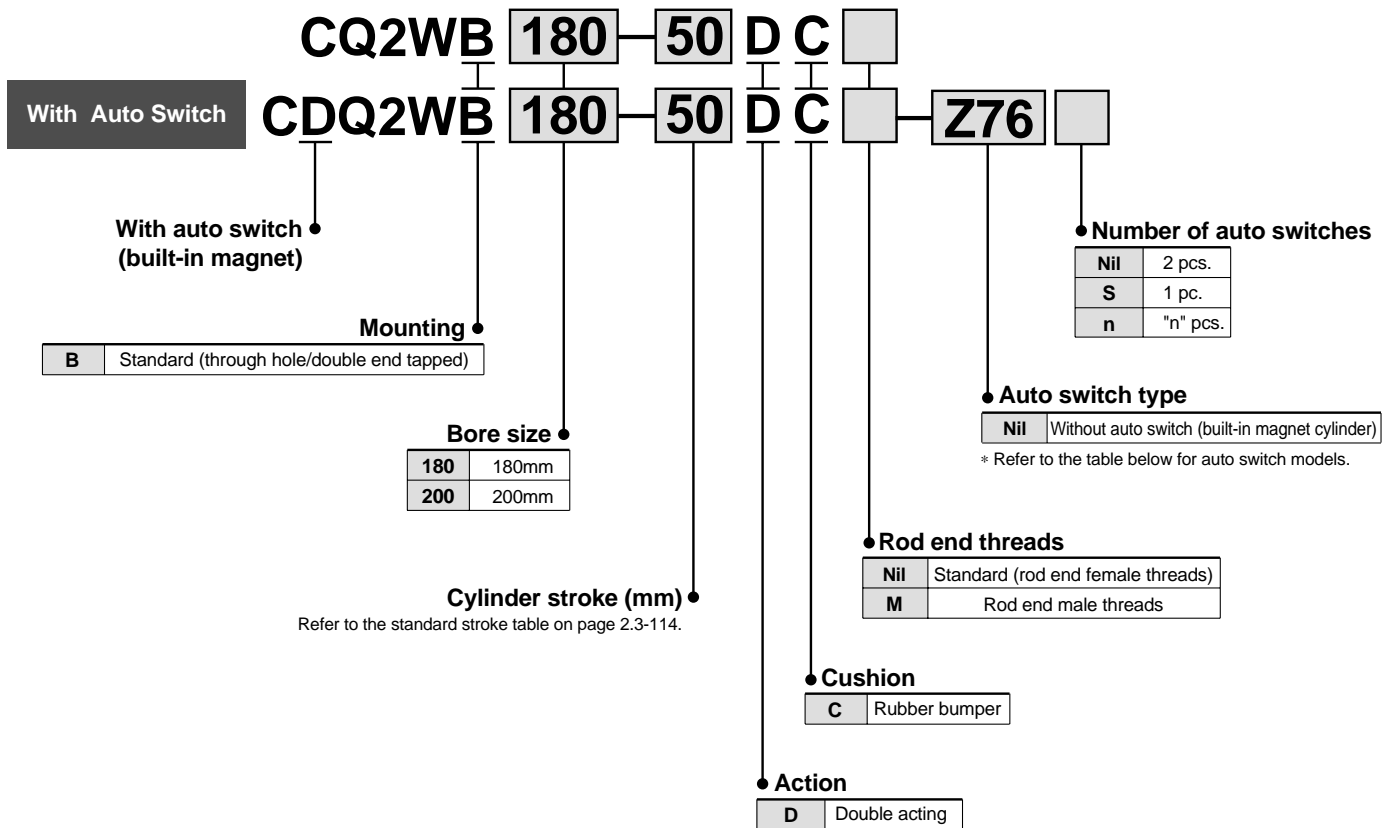

Applicable Auto Switches/Refer to p.5.3-2 for further information on auto switch.

Type	Special function	Electrical entry	Indicator light	Wiring (output)	Load voltage		Auto switch models		Lead wire length (mm)*			Applicable loads		
					DC	AC	Electrical entry direction	0.5 (Nil)	3 (L)	5 (Z)	IC circuit	Relay, PLC		
						Perpendicular	In-line							
Reed switch	-	Grommet	Yes	3 wire	—	5V	—	—	Z76	●	●	—	IC circuit	—
				2 wire	24V	12V	100V	—	Z73	●	●	●	—	Relay, PLC
				3 wire (NPN)	5V, 12V	100V or less	—	Z80	●	●	—	IC circuit	Relay, PLC	
3 wire (PNP)	Y69A	Y59A	●	●			○	IC circuit						
Solid state switch	Diagnostic indication (2 colour indicator) Water resistant (2 colour indicator)	Grommet	Yes	2 wire	24V	12V	—	Y7PV	Y7P	●	●	○	—	Relay, PLC
				3 wire (NPN)		5V, 12V		Y69B	Y59B	●	●	○	IC circuit	
				3 wire (PNP)	5V, 12V	—	Y7NWV	Y7NW	●	●	○	—		
				2 wire		12V	Y7PWV	Y7PW	●	●	○	IC circuit		
				3 wire (NPN)	24V	—	Y7BWV	Y7BW	●	●	○	—		
				3 wire (PNP)		5V, 12V	—	—	Y7BA	—	●	○	—	
2 wire	12V	—	—	—	—	—	—	—	—					

* Lead wire length symbols: 0.5m ... Nil (Example) Y69B
 3m L Y69BL
 5m Z Y69BZ

** Auto switches marked with a "O" symbol are produced upon receipt of order.

Series CQ2



Symbol

Double acting: Double rod

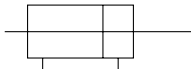

Specifications

Fluid	Air
Proof pressure	1.05MPa
Maximum operating pressure	0.7MPa
Minimum operating pressure	0.05MPa
Ambient and fluid temperature	Without auto switch: -10°C to 70°C (with no freezing)
	With auto switch: -10°C to 60°C (with no freezing)
Lubrication	Non-lube type
Cushion	Rubber bumper
Rod end threads	Female thread
Thread tolerance	JIS class 2
Stroke length tolerance	+1.4 0
Mounting brackets	Basic type
Mounting	Through hole/Double end tapped

Standard Strokes

Bore size (mm)	Standard strokes (mm)
180, 200	10, 20, 30, 40, 50, 75, 100, 125, 150, 175, 200, 250, 300

Minimum Strokes for Auto Switch Mounting

Bore size (mm)	Mounting	D-Z7, Z8	D-Y5, Y6, Y7	D-Y7□W, D-Y7BAL
		180, 200	2 pcs. (different sides, same side)	10
	1 pc.	5	5	10

Theoretical Output/Double Acting

Unit: N

Bore Size (mm)	Operating pressure (MPa)					
	0.2	0.3	0.4	0.5	0.6	0.7
180	4838	7257	9676	12095	14514	16933
200	6032	9048	12064	15080	18096	21112

Do not apply loads greater than 50% of the theoretical output.

Weight Table

Unit: kg

Bore size (mm)	Standard strokes (mm)													With magnet	Rod end male threads
	10	20	30	40	50	75	100	125	150	175	200	250	300	Additional weight	Additional weight
180	12.18	12.70	13.23	13.75	14.28	15.59	16.90	18.21	19.52	20.83	22.14	24.76	27.39	0.08	1.48
200	15.63	16.22	16.80	17.39	17.97	19.44	20.91	22.37	22.84	25.30	26.77	29.70	32.63	0.09	1.48

Example) CDQ2WB200-100DCM

Basic weight	CQ2WB200-100DC	20.91kg
Additional weight	Built-in magnet	0.09kg
	Rod end male threads	1.48kg
	Total	22.48kg

Construction

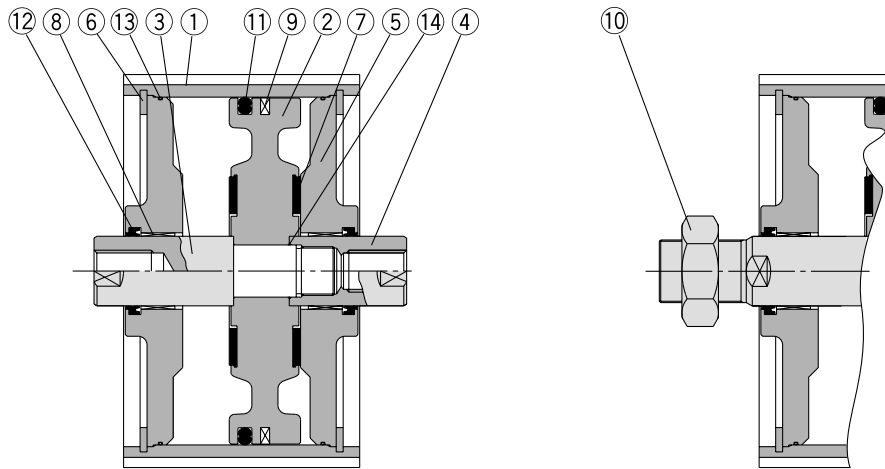

Rod end male threads

Parts list

No.	Description	Material	Note
1	Cylinder tube	Aluminum alloy	Hard anodized
2	Piston	Aluminum alloy casting	Chromated
3	Piston rod A	Carbon steel	Hard chrome plated
4	Piston rod B	Carbon steel	Hard chrome plated
5	Rod cover	Cast iron	Nickel plated
6	Snap ring	Carbon tool steel	Phosphate coated
7	Bumper	Polyurethane	
8	Bushing	Lead-bronze casting	
9	Magnet	-	CDQ2B only
10	Rod end nut	Rolled steel	Nickel plated

Parts list

No.	Description	Material	Note
11	Piston seal	NBR	
12	Rod seal	NBR	
13	Tube gasket	NBR	
14	Piston gasket	NBR	

Replacement parts: Seal kits

Bore size (mm)	Seal kit No.	Contents
180	CQ2WB180-PS	A set of Nos.11, 12 and 13 from the table above
200	CQ2WB200-PS	

Mounting

Mounting/Through hole type mounting bolts are available.
 How to order: Add "Bolt" in front of the bolts to be used.
 (Example) Bolt M18 x 125 ℓ

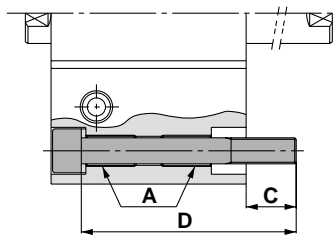

Note1) When mounting with through hole type mounting bolts, be sure to use the flat washers which are included.
 Note 2) When mounting a cylinder with a stroke over 100mm, use the section A mounting threads.

Model	C	D	Mounting bolt
C (D) Q2WB180- 10DC	36	125	M18 x 125 ℓ
C (D) Q2WB180- 20DC		135	M18 x 135 ℓ
C (D) Q2WB180- 30DC		145	M18 x 145 ℓ
C (D) Q2WB180- 40DC		155	M18 x 155 ℓ
C (D) Q2WB180- 50DC		165	M18 x 165 ℓ
C (D) Q2WB180- 75DC		190	M18 x 190 ℓ
C (D) Q2WB180-100DC		215	M18 x 215 ℓ

Model	C	D	Mounting bolt
C (D) Q2WB200- 10DC	39	135	M18 x 135 ℓ
C (D) Q2WB200- 20DC		145	M18 x 145 ℓ
C (D) Q2WB200- 30DC		155	M18 x 155 ℓ
C (D) Q2WB200- 40DC		165	M18 x 165 ℓ
C (D) Q2WB200- 50DC		175	M18 x 175 ℓ
C (D) Q2WB200- 75DC		200	M18 x 200 ℓ
C (D) Q2WB200-100DC		225	M18 x 225 ℓ

CUJ
CU
CQS
CQ2
RQ
MU

Series CQ2

Dimensions

Dimensions are the same with and without auto switches.

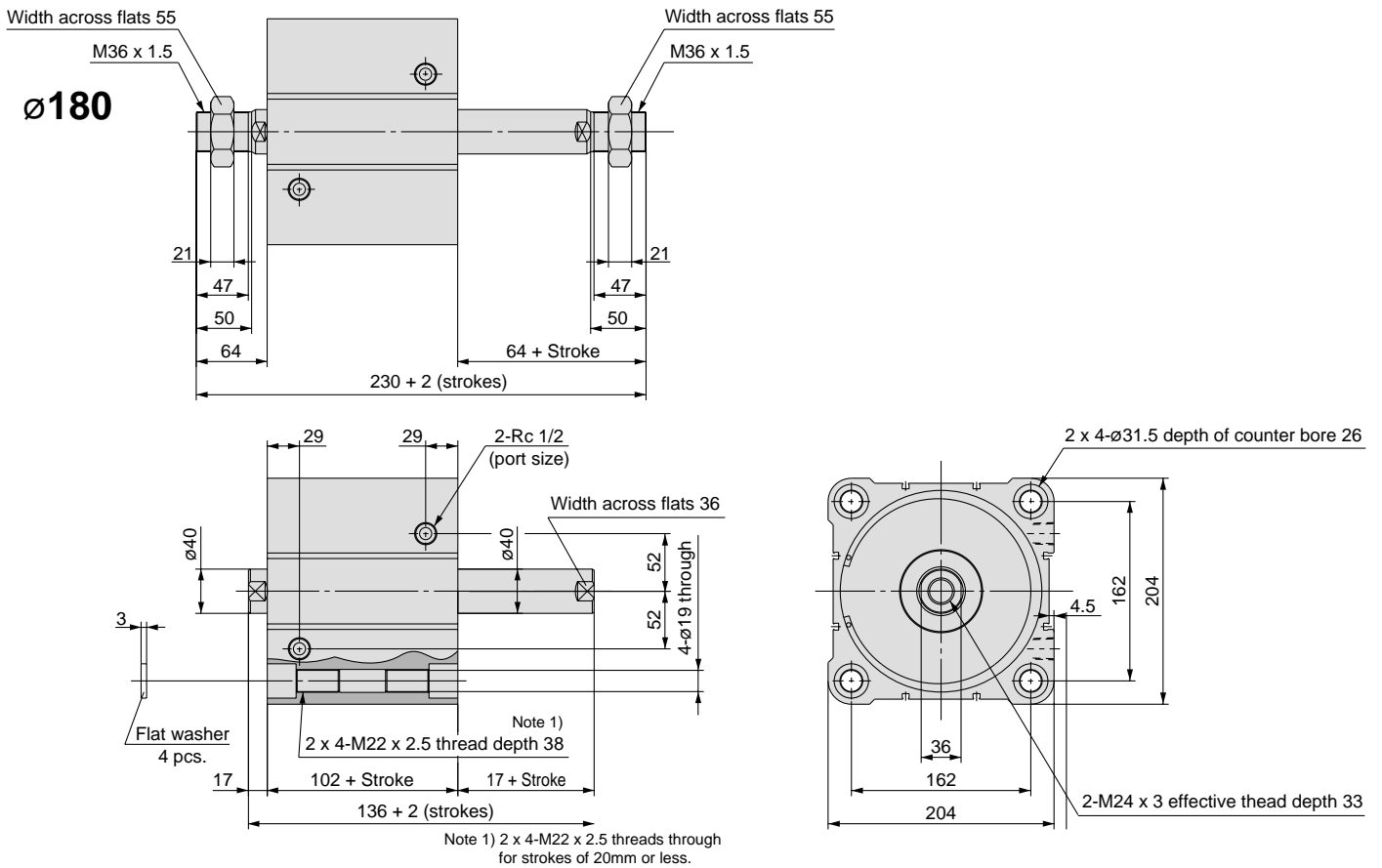

Ø200

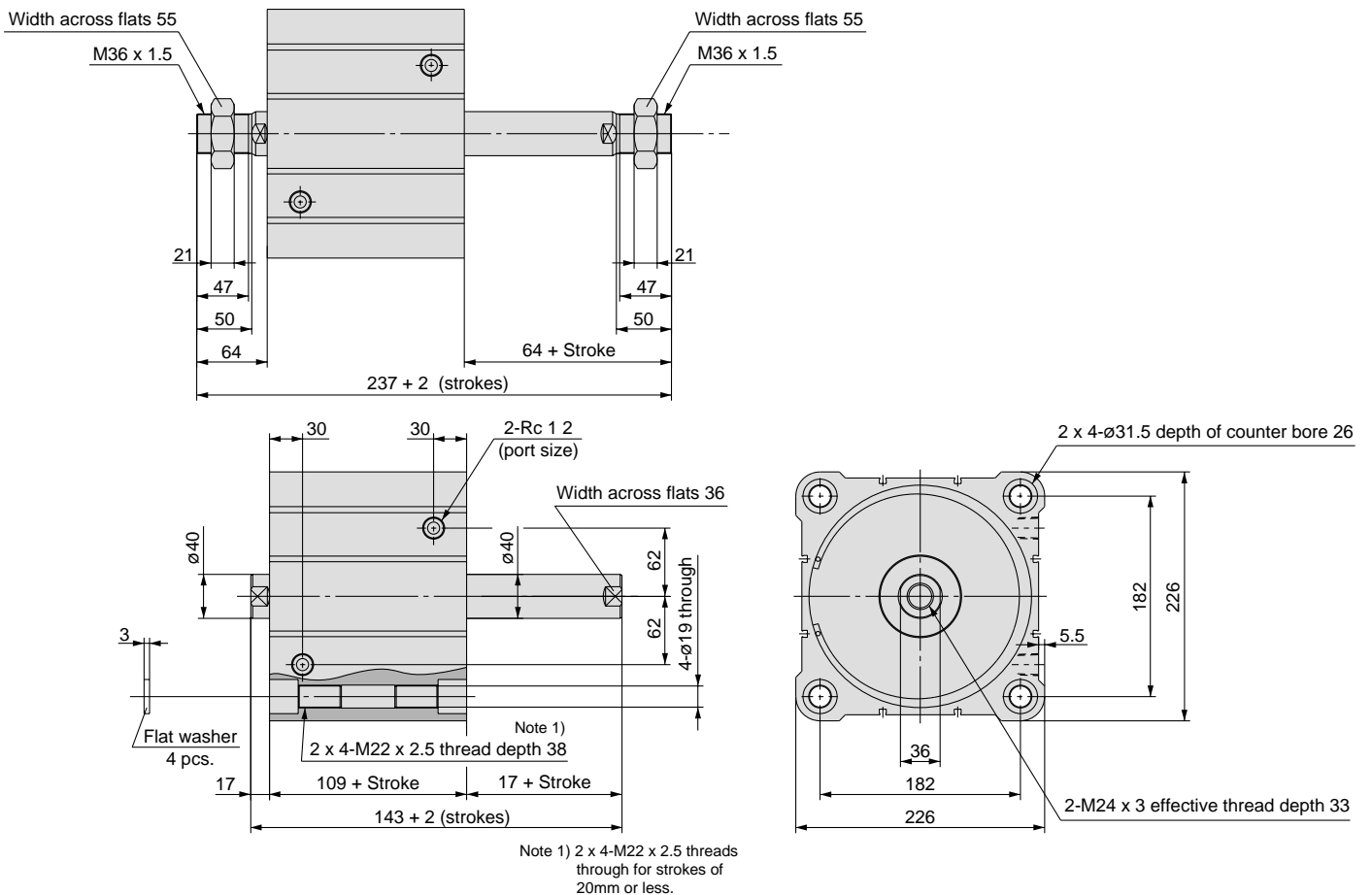

Series CQ2 Auto Switch Mounting

Auto Switches/Proper Mounting Position for Stroke End Detection

Proper mounting position (mm)

Bore size (mm)	A	B
180	38.5	38.5
200	42	42

* Dimensions are the same for single rod and double rod.

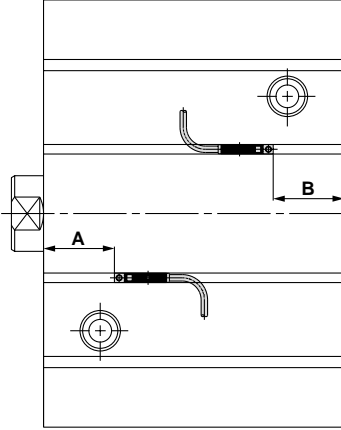

Minimum Strokes for Mounting of Auto Switches

		D-Z7, Z8	D-Y5, Y6, Y7	D-Y7□W D-Y7BAL
180, 200	2 pcs. (different sides, same side)	10	5	15
	1 pc.	5	5	10

Auto Switch Mounting

When mounting an auto switch, insert it into the cylinder's switch mounting groove from the direction shown in the drawing below. After setting it in the desired mounting position, tighten the switch mounting screw which is included using a flat head watchmakers screw driver.

Note) When tightening the auto switch mounting screw (included with auto switch), use a watchmakers screw driver with a handle about 5 to 6mm in diameter. Also tighten with a torque of 0.05 to 0.1N·m. As a rule, it should be turned about 90° past the point at which tightening can be felt.

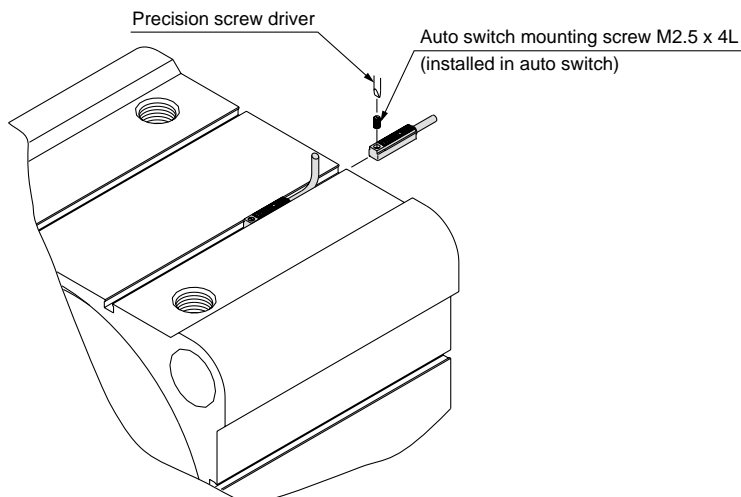

CUJ

CU

CQS

CQ2

RQ

MU

Compact Cylinder/Long Stroke: Double Acting Single Rod

Series CQ2

ø32, ø40, ø50, ø63, ø80, ø100

How to Order

Standard

CQ2 A 32 200 DC

With auto switch

CDQ2 A 32 200 DC A73 S

With auto switch
(Built-in magnet)

Mounting

A	Both ends tapped
L	Foot
F	Front flange
G	Rear flange
D	Double clevis

* Mounting brackets are shipped not assembled with the cylinder.

Bore size

32	32mm	63	63mm
40	40mm	80	80mm
50	50mm	100	100mm

Cylinder stroke (mm)

Refer to standard stroke table on p.2.3-119

Auto switch

Without auto switch
(Built-in magnet)

Number of auto switches

—	2
S	1
n	n

* Refer to table below for selection of auto switch model no.

Body option

—	Standard (Rod end female thread)
M	Rod end male thread

Cushion

C	Rubber bumper
---	---------------

Action

D	Double acting
---	---------------

Applicable Auto switch/Refer to p.5.3-2 for further information on auto switch.

Style	Special function	Electrical entry	Indicator	Wiring (output)	Load voltage		Rail mounting		Direct mounting		Lead wire*(m)				Applicable load			
					DC	AC	Perp.	In-line	Perp.	In-line	0.5 (—)	3 (L)	5 (Z)	None (N)				
Reed switch	—	Grommet	Yes	3 wire (Equiv. NPN)	24V	5V	—	—	A76H	A96V	A96	●	●	—	—	IC		
						—	200V	A72	A72H	—	—	●	●	—	—	—		
						12V	100V	A73	A73H	—	—	●	●	●	—	—	—	
						—	—	—	—	A93V	A93	●	●	—	—	—		
						5V, 12V ≤ 100V	—	A80	A80H	A90V	A90	●	●	—	—	—	IC	
						12V	—	A73C	—	—	—	●	●	●	●	—	—	
Solid state switch	—	Grommet	Yes	3 wire (NPN)	24V	5V, 12V	—	—	F7NV	F79	—	—	●	●	○	—	IC	
						12V	—	—	F9NV	F9N	●	●	—	—	—			
						5V, 12V	—	—	F7PV	F7P	—	—	●	●	○	—	IC	
						—	—	—	—	F9PV	F9P	●	●	—	—	—		
						12V	—	—	F7BV	J79	—	—	●	●	○	—	—	
						—	—	—	—	F9BV	F9B	●	●	—	—	—		
	Diagnostic (2 colour)	—	Grommet	Yes	3 wire (NPN)	24V	5V, 12V	—	—	F7NVV	F79W	—	—	●	●	○	—	—
							12V	—	—	F9NVV	F9NW	●	●	○	—	—	IC	
							5V, 12V	—	—	—	F7PW	—	—	●	●	○	—	—
							—	—	—	—	F9PWW	F9PW	●	●	○	—	—	
							12V	—	—	F7BWW	J79W	F9BWW	F9BW	●	●	○	—	—
							—	—	—	—	F7BA	—	F9BA	—	●	○	—	—
Water resistant (2 colour)	—	Grommet	Yes	3 wire (NPN)	24V	5V, 12V	—	—	—	F7NT	—	—	—	●	○	—	IC	
						—	—	—	—	—	—	—	—	—	—	—		
						—	—	—	—	F79F	—	—	—	●	●	○	—	—
						—	—	—	—	F7LF	—	—	—	●	●	○	—	—

Mounting Bracket Part No.

Bore (mm)	Foot (1)	Flange	Double clevis (3)
32	CQ-L032	CQ-F032	CQ-D032
40	CQ-L040	CQ-F040	CQ-D040
50	CQ-L050	CQ-F050	CQ-D050
63	CQ-L063	CQ-F063	CQ-D063
80	CQ-L080	CQ-F080	CQ-D080
100	CQ-L100	CQ-F100	CQ-D100

Note 1) When ordering foot brackets, 2pcs. should be ordered for each cylinder.

Note 2) Parts attached with each brackets are as follows.

Foot, Flange/Body mounting bolt
Double clevis/Clevis pin,
Body mounting bolt,
C shape snap ring for axis

Note 3) A clevis pin and snap ring are packed with the double clevis.

* Lead wire length 0.5m.....— (Example) A80C 5m.....Z (Example) A80CZ
3m.....L (Example) A80CL None.....N (Example) A80CN

* Solid state switches marked with a "○" are produced upon receipt of order.

Compact Cylinder/Long Stroke: Double Acting Single Rod **Series CQ2**



JIS Symbol

Double acting single rod

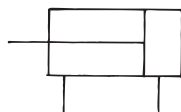

Style

Bore size (mm)		32	40	50	63	80	100
Pneumatic	Built-in magnet	●	●	●	●	●	●
	Piping	Screw-in style	Rc(PT)1/8	Rc(PT)1/8	Rc(PT)1/4	Rc(PT)1/4	Rc(PT)3/8
	Rod end male thread	●	●	●	●	●	●

Specifications

Style	Pneumatic (non-lube)
Fluid	Air
Proof pressure	1.5MPa
Max. operating pressure	1.0MPa
Ambient and fluid temperature	Without auto switch -10°C to 70°C (No freezing)
	With auto switch -10°C to 60°C (No freezing)
Lubrication	Not required
Cushion	Rubber bumper (Standard equipment)
Rod end thread	Female thread
Rod end thread tolerance	JIS class 2
Stroke length tolerance	+1.4 0
Mounting	Both ends tapped
Piston speed	50 to 500mm/s

Minimum Operating Pressure

Unit: MPa

Bore size (mm)	32	40	50	63	80	100
Min. operating pressure	0.05	0.05	0.05	0.05	0.05	0.05

Allowable Kinetic Energy

Unit: J

Bore size (mm)	12	16	20	25	32	40	50	63	80	100
Kinetic energy	0.043	0.075	0.11	0.18	0.29	0.52	0.91	1.54	2.71	4.54

Standard Stroke

Unit: mm

Bore size	Standard stroke
32, 40, 50, 63, 80, 100	125, 150, 175, 200, 250, 300

⚠ Precautions

Be sure to read before handling. Refer to p.0.39 to 0-46 through for Safety Instructions and common precautions.

⚠ Caution

Snap Ring Installation/Removal

- For installation and removal, use an appropriate pair of pliers (tool for installing a C snap ring).
- Exercise caution even when using an appropriate pair of pliers (tool for installing a C snap ring), because of the possibility of the snap ring becoming detached from the tip of the pliers (tool for installing a C snap ring) and flying away, which could injure humans or damage the peripheral equipment. After installing the snap ring, make sure that it is placed securely in the ring groove before supplying air.

Intermediate Strokes (except standard strokes)

Method	Spacer is attached on standard stroke body.	Exclusive body
Model No.	Refer to How to Order for standard model no.	Specify "XB10" at the end of standard model number.
Method	Intermediate strokes at 5mm intervals are available by using spacers with standard stroke cylinders.	Intermediate strokes at 1mm intervals are available by using special body with required stroke.
Stroke range	Bore size	Bore size
	Stroke range	Stroke range
Example	32 to 100	32 to 100
	105 to 300	101 to 300
Example	Model no. : CQ2A50-165DC CQ2A50-17DC with 10mm width spacer. B dimension is 230.5mm.	Model no. : CQ2A50-165DC-XB10 Makes 165 stroke tube. B dimension is 220.5mm.

To order a spacer installed styles with intermediate strokes at 1mm intervals, consult SMC beforehand.

Series CQ2

Copper Free

20 — CQ2A Bore size — Stroke DC(M)
 Copper Free Series • $\phi 32, \phi 40, \phi 50, \phi 63, \phi 80, \phi 100$

To eliminate influences of copper ions or halogen ions during CRT manufacturing processes, copper and fluorine materials are not used as component parts.

Specifications

Style	Double acting single rod
Bore size	$\phi 32, \phi 40, \phi 50, \phi 63, \phi 80, \phi 100$
Proof pressure	1.5MPa
Max. operating pressure	1.0MPa
Rubber bumper	With (standard equipment)
Piping	Screw-in piping
Piston speed	50 to 500mm/S
Mounting	Both ends tapped
Auto switch	Mountable

Allowable Lateral Load at Rod End

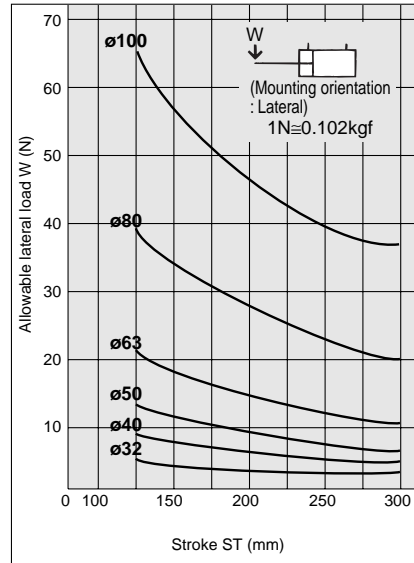

Theoretical Force

Bore size (mm)	Operating direction	Operating pressure (MPa)			Bore size (mm)	Operating direction	Operating pressure (MPa)		
		0.3	0.5	0.7			0.3	0.5	0.7
32	IN	181	302	422	63	IN	841	1400	1960
	OUT	241	402	563		OUT	935	1560	2180
40	IN	317	528	739	80	IN	1360	2270	3170
	OUT	377	628	880		OUT	1510	2510	3520
50	IN	495	825	1150	100	IN	2140	3570	5000
	OUT	589	982	1370		OUT	2360	3930	5500

Weight

Without Auto Switch

Bore size (mm)	Cylinder stroke (mm)					
	125	150	175	200	250	300
32	754	859	965	1070	1279	1490
40	945	1063	1180	1298	1535	1770
50	1469	1650	1832	2007	2376	2739
63	1810	2018	2227	2438	2851	3268
80	3120	3456	3793	4127	4801	5474
100	4956	5374	5790	6020	7042	7875

Built-in Magnet

Bore size (mm)	Cylinder stroke (mm)					
	125	150	175	200	250	300
32	763	868	974	1079	1288	1499
40	958.5	1076.5	1193.5	1311.5	1548.5	1783.5
50	1483.5	1664.5	1846.5	2021.5	2390.5	2753.5
63	1833.5	2041.5	2250.5	2461.5	2874.5	3291.5
80	3144	3480	3817	4151	4825	5498
100	4994	5412	5828	6058	7080	7913

Option Weights

Bore size (mm)		32	40	50	63	80	100
Rod end male thread	Male thread	26	27	53	53	120	175
	Nut	17	17	32	32	49	116
Foot (including mounting bolt)		147	159	253	356	685	1123
Front flange (including mounting bolt)		165	198	348	534	1017	1309
Rear flange (including mounting bolt)		165	198	348	534	1017	1309
Double clevis (including pin, snap ring, bolt)		151	196	393	554	1109	1887

Calculation example: **CQ2D32-200DCM**
 Basic weight: CQ2A32-200DC.....1070g
 Additional weight: Rod end male thread.....43g
 Double clevis.....151g
 1264g

Add the weight of auto switches and mounting brackets when auto switches are mounted.

Weight/Auto Switch Mounting Bracket

Part No.	Bore size	Weight (g)
BQ-2	$\phi 32$ to $\phi 100$	1.5

Refer to p.5.3-75 for auto switch weight.

Compact Cylinder/Long Stroke: Double Acting Single Rod **Series CQ2**

Construction

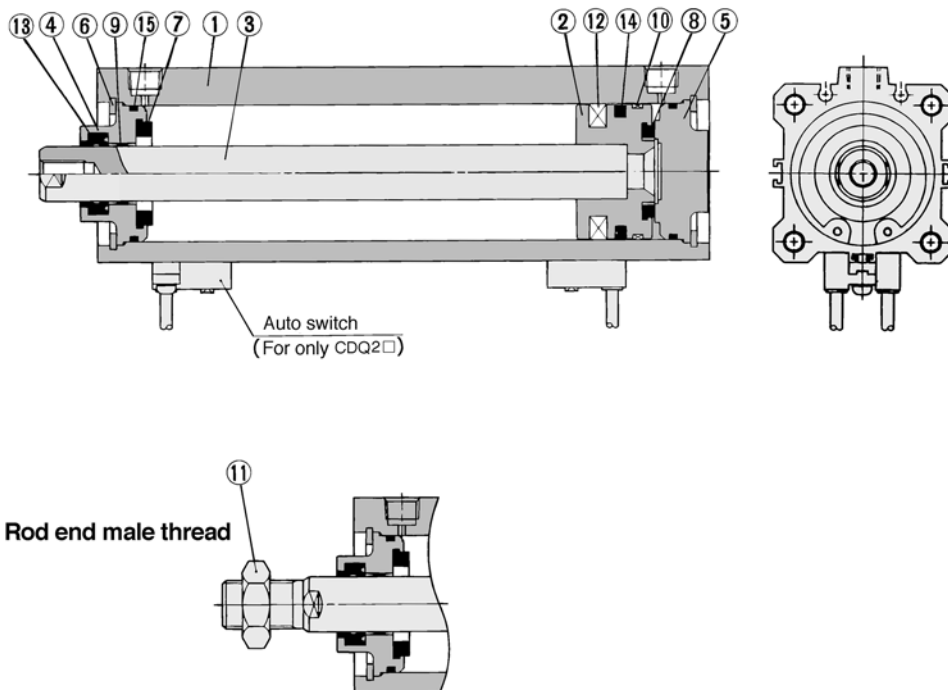

Component Parts

No.	Description	Material	Note
①	Cylinder tube	Aluminum alloy	Hard anodized
②	Piston	Aluminum alloy casting	Chromated
③	Piston rod	Carbon steel	Hard chrome plated
④	Collar	Aluminum alloy	Anodized
⑤	Base plate	Aluminum alloy	Anodized
⑥	Snap ring	Carbon tool steel	Phosphate coating
⑦	Damper A	Urethane	
⑧	Damper B	Urethane	
⑨	Bushing	Lead bronze casting	
⑩	Wearing	Resin	
⑪	Rod end nut	Rolled steel	Nickel plated
⑫	Magnet	—	For only CDQ2□A
⑬*	Rod seal	NBR	
⑭*	Piston seal	NBR	
⑮*	Tube gasket	NBR	

Replacement Parts: Seal Kits

Bore size (mm)	Kit no.	Contents
32	CQ2A32-L-PS	A set includes ⑬, ⑭ and ⑮.
40	CQ2A40-L-PS	
50	CQ2A50-L-PS	
63	CQ2A63-L-PS	
80	CQ2A80-L-PS	
100	CQ2A100-L-PS	

*Seal kits are sets consisting of items ⑬, ⑭ and ⑮, which can be ordered using the kit number for each cylinder bore size.

CUJ

CU

CQS

CQ2

RQ

MU

Series CQ2

ø32 to ø50

Series C□Q2A

The dimensions are the same with or without an auto switch.

Both ends tapped

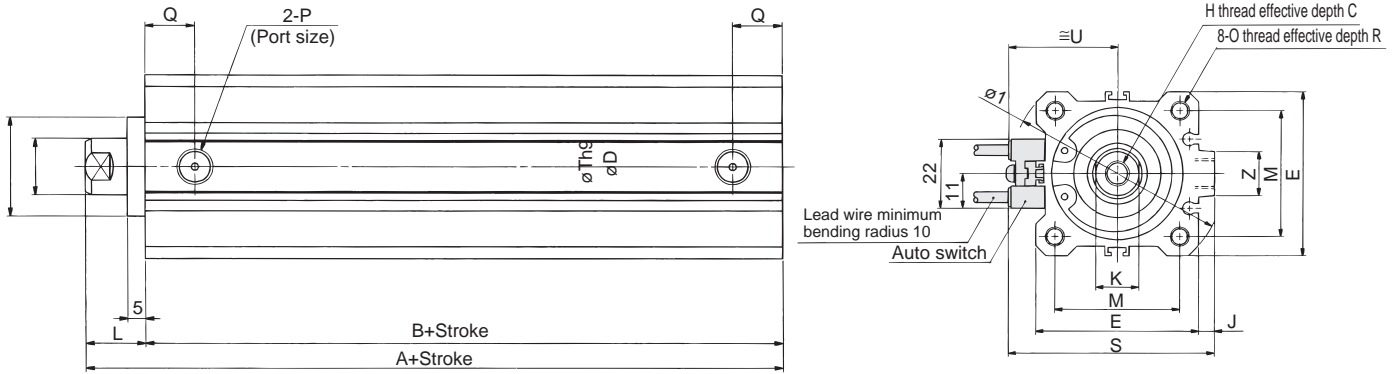

Rod end male thread

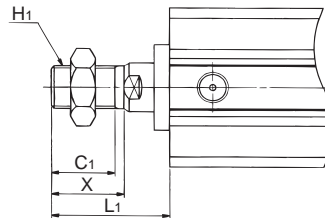

Above switch: D-A73/A80 Refer to p.2.3-126 for auto switch mounting position and mounting height.

Rod end male thread (mm)

Bore (mm)	C1	H1	L1	X
32	20.5	M14 X 1.5	38.5	23.5
40	20.5	M14 X 1.5	38.5	23.5
50	26	M18 X 1.5	43.5	28.5

Both ends tapped

Bore (mm)	Stroke range (mm)	A	B	C	D	E	H	I	J	K	L	M	O	P	Q	R	S	Th9	U	Z
32	125 to 200 (1)	62.5	45.5	13	16	45	M8 X 1.25	60	4.5	14	17	34	M6 X 1.0	Rc(PT)1/8	12.5	10	58.5	22 ⁰ _{-0.052}	31.5	14
	250, 300	72	55	13	16	52	M8 X 1.25	69	5	14	17	40	M6 X 1.0	Rc(PT)1/8	14	10	66	28 ⁰ _{-0.052}	35	14
50		73.5	55.5	15	20	64	M10 X 1.5	86	7	17	18	50	M8 X 1.25	Rc(PT)1/4	14	14	80	35 ⁰ _{-0.062}	41	19



Note 1) All the 125 to 200mm stroke types are in 25mm increments.

Note 2) Refer to p.2.3-3 for calculation of cylinder length with intermediate stroke.

Foot/C□Q2L

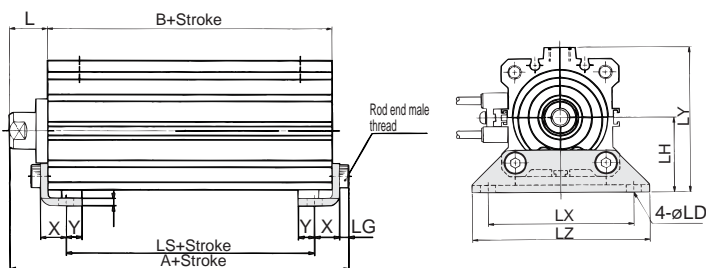

Foot

Bore (mm)	A	B	L	L1	LD	LG	LH	LS	LT	LX	LY	LZ	X	Y
32	69.7	45.5	17	38.5	6.6	4	30	29.5	3.2	57	57	71	11.2	5.8
40	79.2	55	17	38.5	6.6	4	33	39	3.2	64	64	78	11.2	7
50	81.7	55.5	18	43.5	9	5	39	32.5	3.2	79	78	95	14.7	8

* Refer to p.2.3-18 for rod end nut and optional bracket.

Rod end male thread

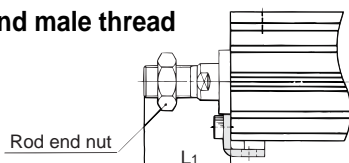

Compact Cylinder/Long Stroke: Double Acting Single Rod **Series CQ2**

Front flange/C□Q2F

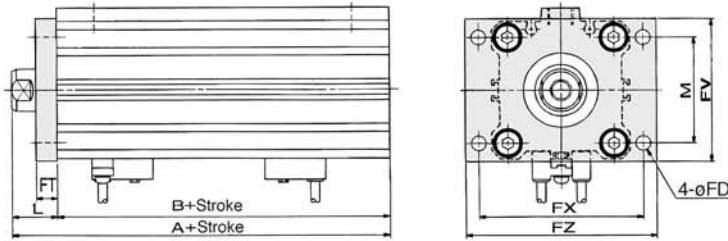

Front flange

(mm)											
Bore (mm)	A	B	FD	FT	FV	FX	FZ	L	L1	M	
32	62.5	45.5	5.5	8	48	56	65	17	38.5	34	
40	72	55	5.5	8	54	62	72	17	38.5	40	
50	73.5	55.5	6.6	9	67	76	89	18	43.5	50	

Rod end male thread

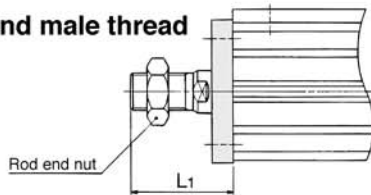

Rear flange/C□Q2G

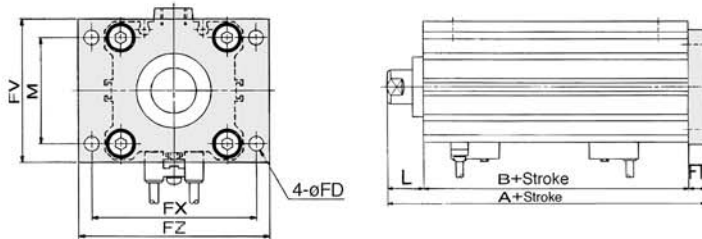

Rear flange (mm)

Bore (mm)	A
32	70.5
40	80
50	82.5

*Dimensions except A are same as front flange type.

CUJ

CU

CQS

CQ2

RQ

MU

Rod end thread

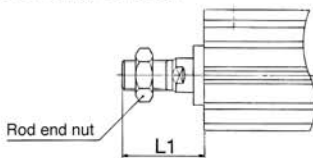

Double clevis

(mm)										
Bore (mm)	A	B	CD	CL	CT	CU	CW	CX	CZ	
32	92.5	45.5	10	82.5	5	14	20	18	36	
40	104	55	10	94	6	14	22	18	36	
50	115.5	55.5	14	101.5	7	20	28	22	44	

Bore (mm)	L	L1	N	RR
32	17	38.5	M6 X 1.0	10
40	17	38.5	M6 X 1.0	10
50	18	43.5	M8 X 1.25	14

*Refer to p.2.3-18 & 19 for rod end nut and optional bracket.

**A clevis pin and snap ring are packed with the double clevis type.

Double clevis/C□Q2D

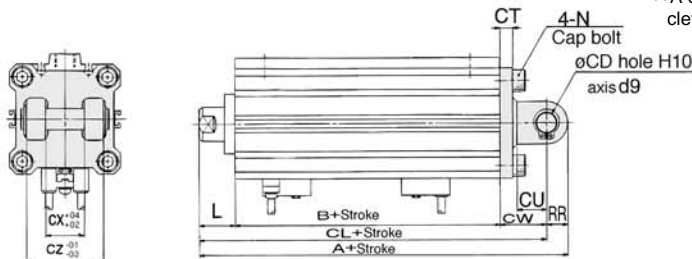

Rod end male thread

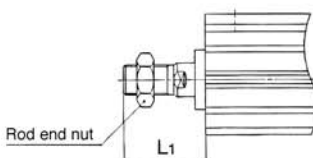

Series CQ2

ø63 to ø100

Series C□Q2A

The dimensions are the same with or without an auto switch.

Both ends tapped

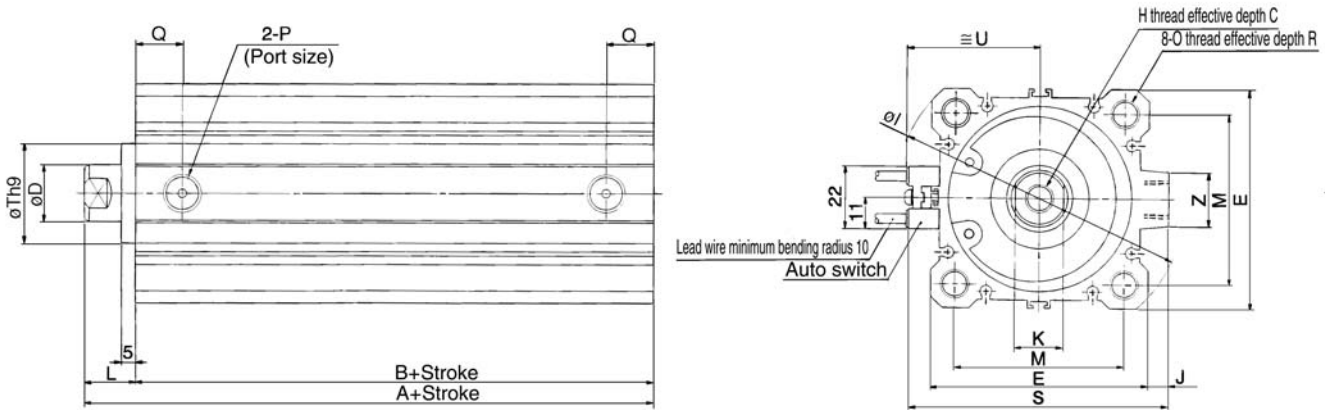

Rod end male thread



Above auto switch: D-A73/A80 Refer to p.2.3-126 for auto switch mounting position and mounting height.

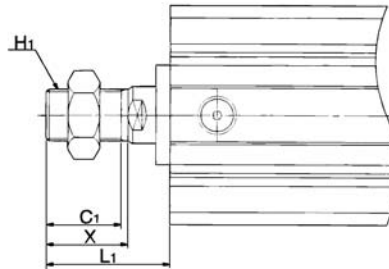

Rod end male thread (mm)

Bore (mm)	C1	H1	L1	X
63	26	M18 X 1.5	43.5	28.5
80	32.5	M22 X 1.5	53.5	35.5
100	32.5	M26 X 1.5	53.5	35.5

Both ends tapped

		(mm)																		
Bore (mm)	Stroke range (mm)	A	B	C	D	E	H	I	J	K	L	M	O	P	Q	R	S	Th9	U	Z
63	125 to 200 ⁽¹⁾ 250, 300	75	57	15	20	77	M10 X 1.5	103	7	17	18	60	M10 X 1.5	Rc(PT)1/4	16.5	18	93	35 ⁰ _{-0.062}	47.5	19
80		86	66	21	25	98	M16 X 2.0	132	6	22	20	77	M12 X 1.75	Rc(PT)3/8	19	22	112.5	43 ⁰ _{-0.062}	57.5	26
100		97.5	75.5	27	30	117	M20 X 2.5	156	6.5	27	22	94	M12 X 1.75	Rc(PT)3/8	23	22	132.5	59 ⁰ _{-0.074}	67.5	26



Note 1) All the 125 to 200mm stroke types are in 25mm increments. Refer to p.2.3-3 for calculation of cylinder length with intermediate stroke.

Foot/C□Q2L

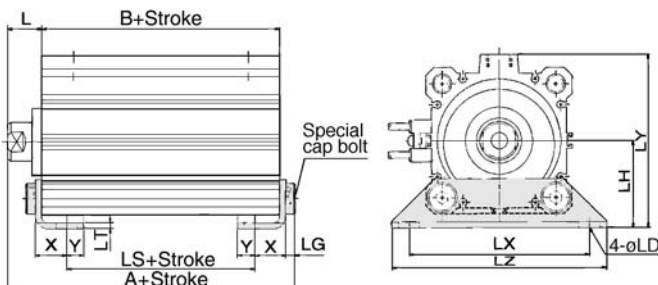

Foot

		(mm)													
Bore (mm)		A	B	L	L1	LD	LG	LH	LS	LT	LX	LY	LZ	X	Y
63		83.2	57	18	43.5	11	5	46	31	3.2	95	91.5	113	16.2	9
80		97.5	66	20	53.5	13	7	59	36	4.5	118	114	140	19.5	11
100		110.5	75.5	22	53.5	13	7	71	41.5	6	137	136	162	23	12.5

* Refer to p.2.3-18 & 19 for rod end nut and optional bracket.

Rod end male thread

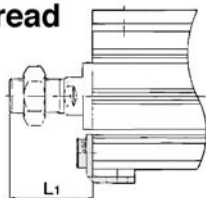

Compact Cylinder/Long Stroke: Double Acting Single Rod **Series CQ2**

Front flange/C□Q2F

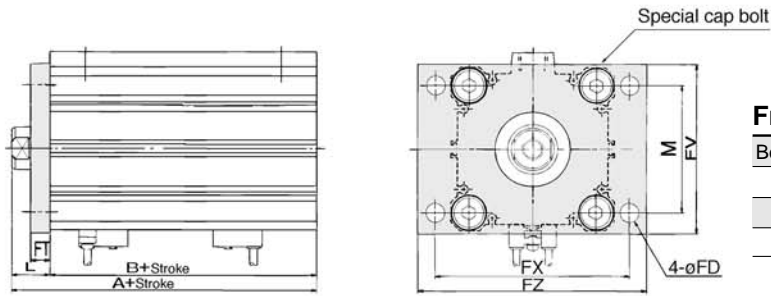

Front flange

		(mm)									
Bore (mm)	A	B	FD	FT	FV	FX	FZ	L	L1	M	
63	75	57	9	9	80	92	108	18	43.5	60	
80	86	66	11	11	99	116	134	20	53.5	77	
100	97.5	75.5	11	11	117	136	154	22	53.5	94	

Rod end male thread

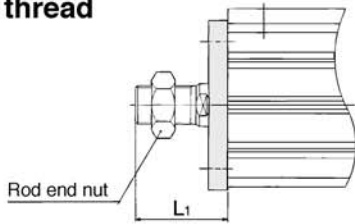

Rear flange/C□Q2G

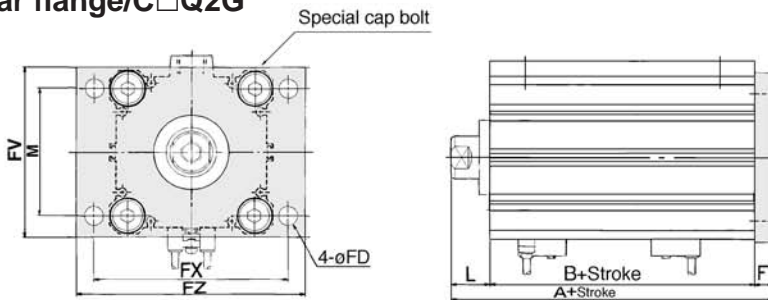

Rear flange (mm)

Bore (mm)	A
63	84
80	97
100	108.5

*Dimensions except A are same as front flange type.

Rod end male thread

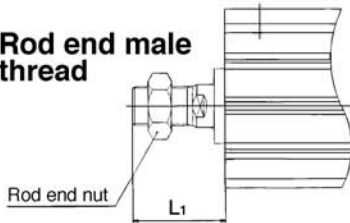

Double clevis/C□Q2D

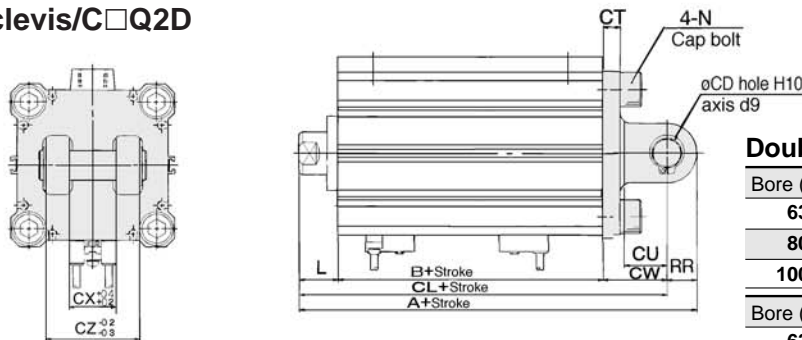

Double clevis

		(mm)								
Bore (mm)	A	B	CD	CL	CT	CU	CW	CX	CZ	
63	119	57	14	105	8	20	30	22	44	
80	142	66	18	124	10	27	38	28	56	
100	164.5	75.5	22	142.5	13	30	45	32	64	

Bore (mm)	L	L1	N	RR
63	18	43.5	M10 X 1.5	14
80	20	53.5	M12 X 1.75	18
100	22	53.5	M12 X 1.75	22

*Refer to p.2.3-18 & 19 for rod end nut and optional bracket.
 **A clevis pin and snap ring are packed with the double clevis.

Rod end male thread

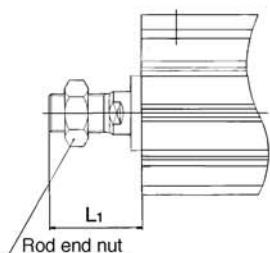

CUJ

CU

CQS

CQ2

RQ

MU

Series CDQ2

Auto Switch Specifications



* Refer to p.5.3-2 for of auto switch specifications.



Standard Specifications

Fluid	Air
Ambient and fluid temperature	-10°C to 60°C (No freezing)

Other specifications are same as one on p.2.3-119.

How to Order

Refer to p.2.3-118 for "How to Order" with auto switch.

Auto Switch Mounting Position (at Stroke End) and Mounting Height

D-A7□
D-A80

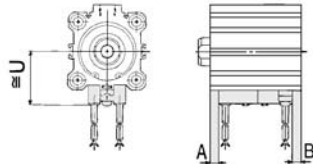

D-A73C
D-A80C
D-J79C

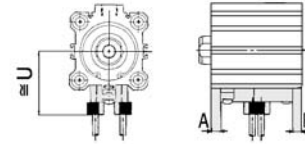

D-A7□H D-F7□W
D-A80H D-J79W
D-F7□ D-F7□F
D-J79 D-F7NTL
D-F7BAL

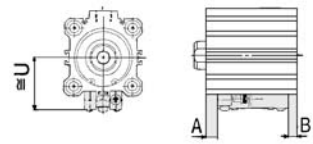

D-A79W
D-F7□WV
D-F7□V

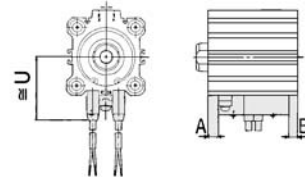

D-A9□
D-F9□

D-A9□V
D-F9□V
D-F9□WV

D-F9□W
D-F9BAL

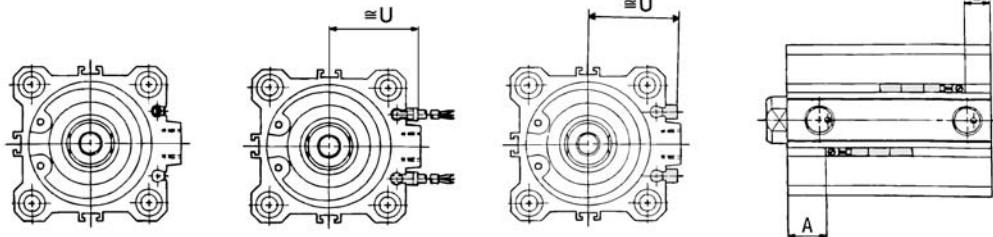

Auto Switch Mounting Position

Bore size (mm)	D-A7□ D-A80		D-A7□H D-A80H D-A73C D-A80C D-F7□ D-J79 D-F7□V D-J79C		D-A79W		D-F7□W D-F7BAL D-F7□F D-J79W D-F7□WV		D-A9□ D-A9□V		D-F9□ D-F9□V		D-F9□W D-F9□WV D-F7BAL	
	A	B	A	B	A	B	A	B	A	B	A	B	A	B
32	9.5	17.5	10	18	7	15	14	22	8.5	16.5	12.5	20.5	11.5	19.5
40	13	23.5	13.5	24	10.5	21	17.5	28	12	22.5	16	26.5	15	25.5
50	11	24	11.5	24.5	8.5	21.5	15.5	28.5	10	23	14	27	13	26
63	13.5	25.5	14	26	11	23	18	30	12.5	24.5	16.5	28.5	15.5	27.5
80	16.5	31.5	17	32	14	29	21	36	15.5	30.5	19.5	34.5	18.5	33.5
100	19.5	38	20	38.5	17	35.5	24	42.5	18.5	37	22.5	41	21.5	40

Auto Switch Mounting Height

(mm)

D-A7□ D-A80	D-A7□H D-A80H D-F7□ D-J79 D-F7□W D-F7BAL D-F7□F D-F7NTL	D-A73C D-A80C	D-F7□V D-F7□WV	D-J79C	D-A79W	D-A9□V	D-F9□V D-F9□WV	D-F9□V D-F9BAL	U
									U
31.5	32.5	38.5	35	38	34	27	29	26.5	
35	36	42	38.5	41.5	37.5	30.5	32.5	30	
41	42	48	44.5	47.5	43.5	36.5	38.5	36	
47.5	48.5	54.5	51	54	50	40	42	39.5	
57.5	58.5	64.5	61	64	60	50	52	49.5	
67.5	68.5	74.5	71	74	70	60	62	59.5	

Auto Switch Mounting Bracket Part No.

Bore size (mm)	Part No.	Note	Applicable switch	
			Reed switch	Solid state switch
32, 40 50, 63 80, 100	BQ-2	<ul style="list-style-type: none"> Switch mounting screw (M3 X 0.5 X 10z) Switch interface Switch mounting nut 	D-A7□, A80 D-A73C, A80C D-A7□H, A80H D-A79W	D-F7□, J79 D-F□V D-J79C D-F7□W, J79W D-F7□WV D-F7BAL D-F7□F, D-F7NTL



*Mounting screw set made by stainless steel

Following stainless steel mounting screw set (included nut) is provided. Use them with accordance in environment. (Auto switch interface is not included. Order it separately.)

BBA2: For D-A7/A8/F7/J7

When D-F7BAL mounted on cylinder is required, the stainless steel screw mentioned above is used at shipping. When auto switch unit is shipped, BBA2 is attached.

CUJ

CU

CQS

CQ2

RQ

MU

Compact Cylinder/Anti-lateral Load

Series CQ2

ø32, ø40, ø50, ø63, ø80, ø100

How to Order

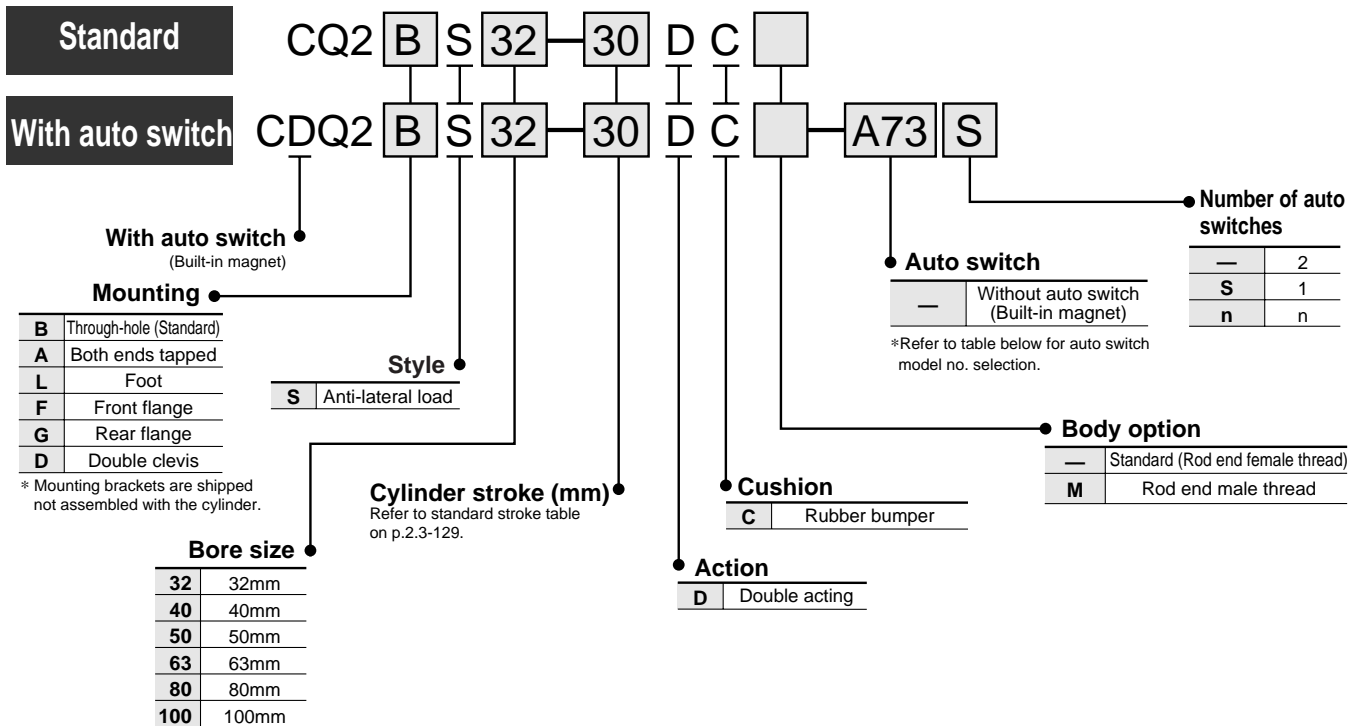

Applicable Auto Switches/Refer to p.5.3-2 for further information on auto switch.

Style	Special function	Electrical entry	Indicator	Wiring (Output)	Load voltage		Rail mounting		Direct mounting		Lead wire*(m)				Applicable load				
					DC	AC	Perp.	In-line	Perp.	In-line	0.5 (-)	3 (L)	5 (Z)	None (N)					
Reed switch	—	Grommet	Yes	3 wire (Equiv.NPN)	—	5V	—	—	A76H	A96V	A96	●	●	—	—	IC	Relay, PLC		
						—	200V	A72	A72H	—	—	●	●	—	—	—			
						12V	100V	A73	A73H	—	—	●	●	●	—	—		—	
						—	—	—	—	A93V	A93	●	●	—	—	—		—	
						24V	5V, 12V ≤ 100v	A80	A80H	A90V	A90	●	●	—	—	—		—	IC
						—	12V	A73C	—	—	—	●	●	●	—	—		—	—
Solid state switch	—	Grommet	Yes	3 wire (NPN)	24V	5V, 12V	—	F7NV	F79	—	—	●	●	○	—	IC	Relay, PLC		
						—	—	F9NV	F9N	●	●	—	—	—	—				
						5V, 12V	—	F7PV	F7P	—	—	●	●	○	—	—			
						—	—	—	—	F9PV	F9P	●	●	—	—	—			
						12V	—	F7BV	J79	—	—	●	●	○	—	—			
						—	—	—	—	F9BV	F9B	●	●	—	—	—			
						—	—	J79C	—	—	—	●	●	●	—	—			
						5V, 12V	—	F7NWX	F79W	—	—	●	●	○	—	—			
						—	—	—	—	F9NWX	F9NW	●	●	○	—	—			
						12V	—	F7PW	—	—	—	●	●	○	—	—			
						—	—	—	—	F9PW	F9PW	●	●	—	—	—			
						12V	—	F7BWX	J79W	F9BWX	F9BW	●	●	○	—	—			
—	—	—	—	F7BA	—	F9BA	—	—	○	—									
5V, 12V	—	—	—	F7NT	—	—	—	—	○	—									
—	—	—	—	F79F	—	—	●	●	○	—	IC								
—	—	—	—	F7LF	—	—	●	●	○	—	—								

Mounting Bracket Part No.

Bore (mm)	Foot (1)	Flange	Double clevis
32	CQ-L032	CQ-F032	CQ-D032
40	CQ-L040	CQ-F040	CQ-D040
50	CQ-L050	CQ-F050	CQ-D050
63	CQ-L063	CQ-F063	CQ-D063
80	CQ-L080	CQ-F080	CQ-D080
100	CQ-L100	CQ-F100	CQ-D100

Note 1) When ordering foot brackets, 2pcs. should be ordered for each cylinder.

Note 2) Parts attached with each brackets are as follows. Foot, Flange/Body mounting bolt, Double clevis/Clevis pin, C shape snap ring for axis, Body mounting bolt

*Lead wire length 0.5m----- (Example) A80C 5m----- Z (Example) A80CZ
3m----- L (Example) A80CL None----- N (Example) A80CN

*Solid state switches marked with a "O" are manufactured produced upon receipt of order.

Compact Cylinder/Anti-lateral Load Series CQ2

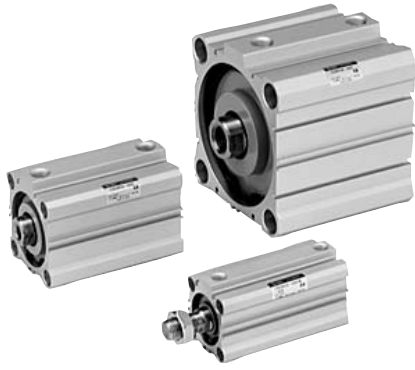

Style

Bore size(mm)		32	40	50	63	80	100	
Pneumatic	Mounting	Through-hole (standard)	●	●	●	●	●	
		Both ends tapped	●	●	●	●	●	
	Built-in magnet		●	●	●	●	●	
	Screw-in piping		Rc(PT)1/8	Rc(PT)1/8	Rc(PT)1/4	Rc(PT)1/4	Rc(PT)3/8	Rc(PT)3/8
	Rod end male thread		●	●	●	●	●	●
	With rubber bumper (Standard)		●	●	●	●	●	●

Specifications

Style	Pneumatic (non-lube) type
Fluid	Air
Proof pressure	1.5MPa
Max. operating pressure	1.0MPa
Ambient and fluid temperature	Without auto switch: -10°C to 70°C (No freezing)
	With auto switch: -10°C to 60°C (No freezing)
Rubber bumper	Standard equipment
Rod end thread	Female thread
Rod end thread tolerance	JIS class 2
Stroke length tolerance	+0.1 0
Mounting	Through-hole
Piston speed	50 to 500mm/s

JIS symbol

Double acting/Single rod

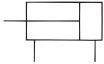

⚠ Precautions

Be sure to read before handling.
Refer to p.0-39 to 0-46 Safety Instructions and common precautions.

⚠ Caution

Snap Ring Installation/Removal

- For installation and removal, use an appropriate pair of pliers (tool for installing a C snap ring).
- Exercise caution even when using an appropriate pair of pliers (tool for installing a C snap ring), because of the possibility of the snap ring becoming detached from the tip of the pliers (tool for installing a C snap ring) and flying away, which could injure humans or damage the peripheral equipment. After installing the snap ring, make sure that it is placed securely in the ring groove before supplying air.

Minimum Operating Pressure

Unit: MPa

Bore size(mm)	32	40	50	63	80	100
Pneumatic (non-lube)	0.05	0.05	0.05	0.05	0.05	0.05

Standard Stroke

Unit: mm

Bore size(mm)	Standard stroke
32, 40	5, 10, 15, 20, 25, 30, 35, 40, 45, 50, 75, 100
50, 63, 80, 100	10, 15, 20, 25, 30, 35, 40, 45, 50, 75, 100

Theoretical Force

Unit: N

Bore size (mm)	Operating direction	Operating pressure(MPa)		
		0.3	0.5	0.7
32	IN	181	302	422
	OUT	241	402	563
40	IN	317	528	739
	OUT	377	628	880
50	IN	495	825	1150
	OUT	589	982	1370
63	IN	841	1400	1960
	OUT	935	1560	2180
80	IN	1360	2270	3170
	OUT	1510	2510	3520
100	IN	2140	3570	5000
	OUT	2360	3930	5500

Allowable Kinetic Energy

Unit: J

Bore size(mm)	12	16	20	25	32	40	50	63	80	100
Kinetic energy	0.043	0.075	0.11	0.18	0.29	0.52	0.91	1.54	2.71	4.54

Auto Switch Mounting Bracket Part No.

Bore size (mm)	Part No.	Note	Applicable switch	
			Reed switch	Solid state switch
32/40/50 63/80/100	BQ-2	<ul style="list-style-type: none"> Switch mounting screw (M3 X 0.5 X 10 ϕ) Switch interface Switch mounting nut 	D-A7□, A80 D-A73C, A80C D-A7□H, A80H D-A79W	D-F7□, J79 D-F7□V D-J79C D-F7□W, J79W D-F7□WV D-F7BAL D-F7□F

Series CQ2

Rod End Allowable Load

Without auto switch

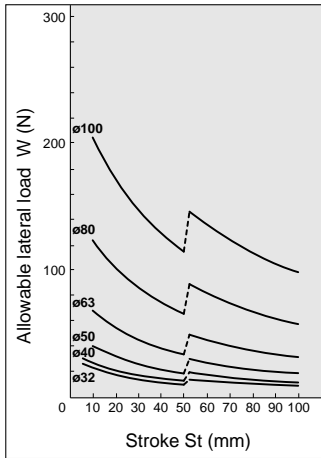

With auto switch

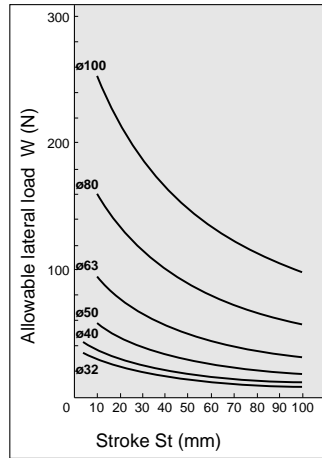

Weight

Unit: g

Bore size (mm)	Cylinder stroke (mm)											
	5	10	15	20	25	30	35	40	45	50	75	100
32	142	163	184	204	225	246	267	287	308	329	482	587
40	224	247	270	293	316	339	362	386	409	432	616	736
50	—	400	436	472	508	545	581	617	653	690	982	1170
63	—	589	630	671	712	753	794	835	876	916	1264	1475
80	—	1079	1147	1215	1282	1350	1418	1486	1554	1622	2194	2528
100	—	1863	1953	2044	2135	2226	2316	2407	2498	2589	3393	3853

Option Weights

Unit: g

Bore size	32	40	50	63	80	100
Both ends tapped	6	6	6	19	45	45
Rod end male thread	Male thread	26	27	53	53	120
	Nut	17	17	32	32	49
Foot (including mounting bolt)	143	155	243	324	696	1062
Front flange (including mounting bolt)	180	214	373	559	1056	1365
Rear flange (including mounting bolt)	165	198	348	534	1017	1309
Double clevis (including pin, snap ring, bolt)	151	196	393	554	1109	1887

Calculations

Standard

Calculation example: CQ2DS32-20DCM

•Basic weight : CQ2BS32-20DC..... 204g

•Additional weight: Both end tapped..... 6g

Rod end male thread..... 43g

Double clevis..... 151g

404g

Construction

Rod end male thread

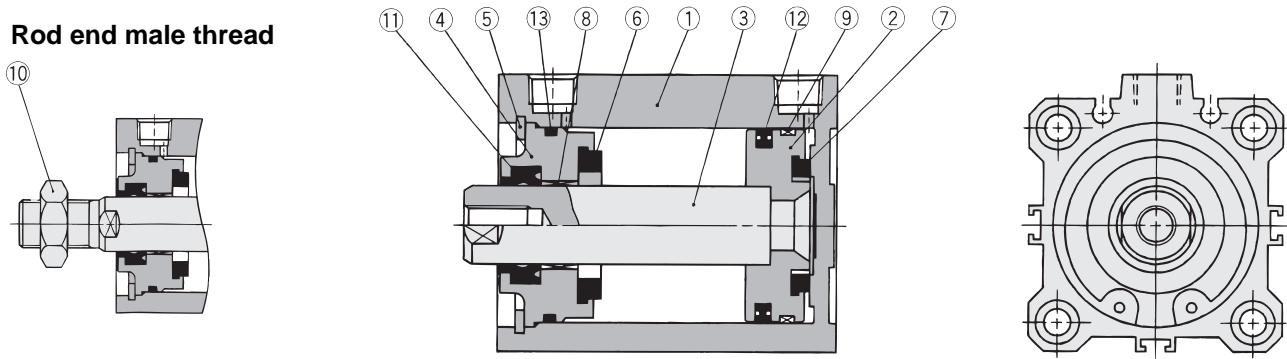

Component Parts

No.	Description	Material	Note
①	Cylinder tube	Aluminum alloy	Hard anodized
②	Piston	Aluminum alloy	Chromated
③	Piston rod	Carbon steel	Hard chrome plated
④	Collar	Aluminum alloy	Anodized
⑤	Snap ring	Carbon tool steel	Phosphate coating
⑥	Bumper A	Urethane	
⑦	Bumper B	Urethane	
⑧	Bushing	Lead bronze casting	
⑨	Wearing	Resin	
⑩	Rod end nut	Carbon steel	Nickel plated
⑪	Rod seal	NBR	
⑫	Piston seal	NBR	
⑬	Tube gasket	NBR	

Replacement Parts: Seal Kits

Bore size (mm)	Kit No.	Contents
32	CQ2B32-PS	A set includes ⑪, ⑫ and ⑬
40	CQ2B40-PS	
50	CQ2B50-PS	
63	CQ2B63-PS	
80	CQ2B80-PS	
100	CQ2B100-PS	

*Seal kits are sets consisting of items ⑪, ⑫ and ⑬, which can be ordered using the kit number for each cylinder bore size.

CUJ

CU

CQS

CQ2

RQ

MU

Series CDQ2

Auto Switch Specifications



* Refer to p.5.3-2 for auto switch specifications.



Standard specifications

Style	Pneumatic (non-lube)
Fluid	Air
Ambient and fluid temperature	-10° to 60°C (No freezing)

Other specifications are same as one on p.2.3-129.

How to Order

Refer to p.2.3-128 for "How to Order" with auto switch.

Weight

Unit: g

Bore (mm)	Cylinder stroke											
	5	10	15	20	25	30	35	40	45	50	75	100
32	201	222	243	263	284	305	326	346	367	388	493	598
40	300	323	347	370	393	416	439	462	485	508	628	748
50	—	518	554	590	626	663	699	735	771	808	996	1184
63	—	748	788	829	870	911	952	993	1034	1075	1286	1497
80	—	1340	1408	1476	1543	1611	1679	1747	1815	1883	2217	2552
100	—	2242	2333	2424	2514	2605	2696	2787	2877	2968	3428	3888

Option Weights

Unit: g

Bore size(mm)	32	40	50	63	80	100
Both ends tapped	6	6	6	19	45	45
Rod end	26	27	53	53	120	175
Rod end male thread	Male thread	26	27	53	53	120
	Nut	17	17	32	32	49
Front flange (included mounting bolt)	143	155	243	324	696	1062
Rear flange (included mounting bolt)	165	198	348	534	1017	1309
Double clevis (included pin, snap ring, bolt)	151	196	393	554	1109	1887

Add the weight of auto switches and mounting brackets when auto switches are mounted.

With auto switch

Calculation example: CDQ2DS32-20DCM

- Basic weight: CDQ2BS32-20DC.....263g
- Additional weight: Both ends tapped..... 6g
- Rod end male thread..... 43g
- Double clevis..... 151g

463g

Weight/Auto Switch Mounting Bracket

Mounting bracket	Cylinder bore size	Weight(g)
BQ-2	ø32 to ø50	1.5

Refer to p.5.3-75 for auto switch weight.

Construction

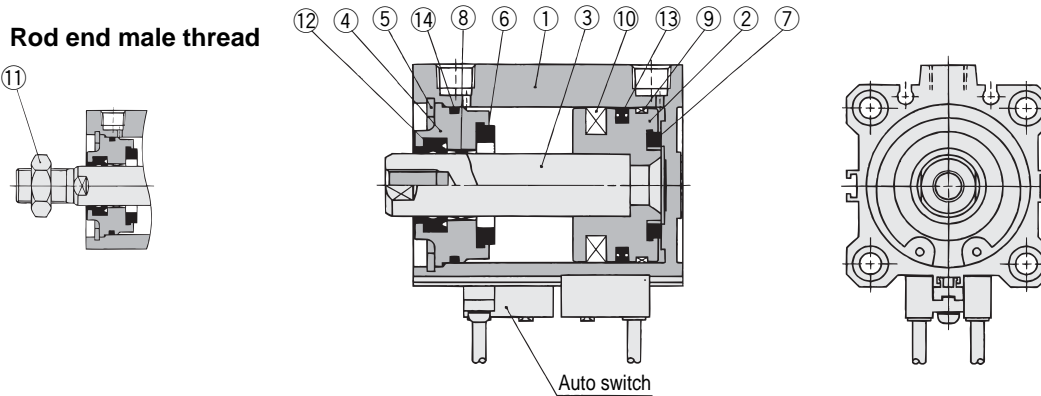

Component Parts

No.	Description	Material	Note
①	Cylinder tube	Aluminum alloy	Hard anodized
②	Piston	Aluminum alloy	Chromated
③	Piston rod	Carbon steel	Hard chrome plated
④	Collar	Aluminum alloy	Anodized
⑤	Snap ring	Aluminum alloy	Phosphate coating
⑥	Bumper A	Urethane	
⑦	Bumper B	Urethane	
⑧	Bushing	Lead bronze casting	
⑨	Wearing	Resin	
⑩	Magnet	—	
⑪	Rod end nut	Carbon steel	
⑫	Rod seal	NBR	
⑬	Piston seal	NBR	
⑭	Tube gasket	NBR	

Replacement Parts: Seal Kits

Bore size(mm)	Kit No.	Contents
32	CQ2BS32-PS	A set includes ⑫, ⑬ and ⑭.
40	CQ2BS40-PS	
50	CQ2BS50-PS	
63	CQ2BS63-PS	
80	CQ2BS80-PS	
100	CQ2BS100-PS	

* Seal kits are sets consisting of items ⑫, ⑬ and ⑭, which can be ordered using the kit number for each cylinder bore size.

Auto Switch Mounting Position (at Stroke End) and Mounting Height

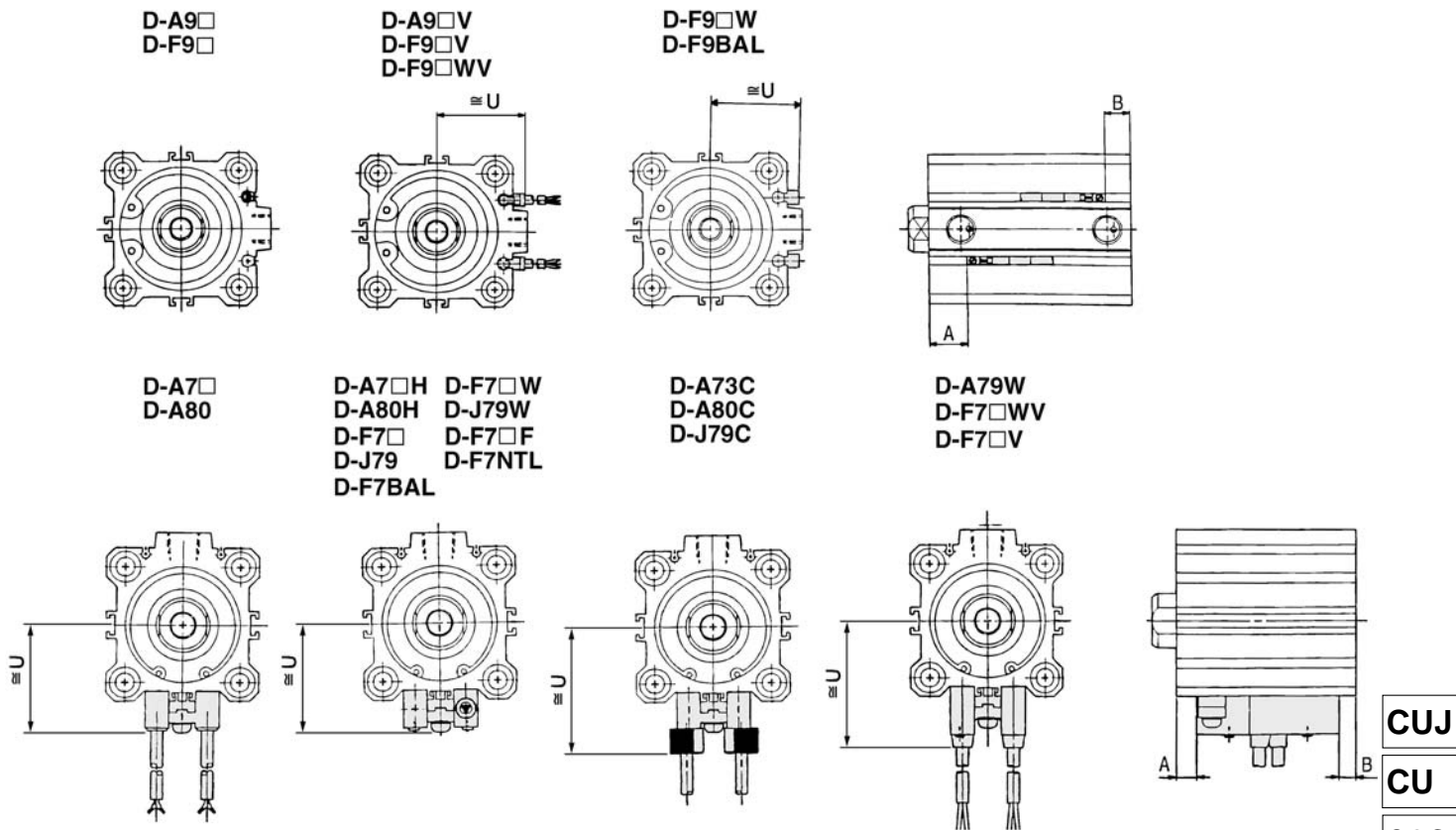

Auto Switch Mounting Position

Bore size (mm)	D-A7□/A80		D-A7□H/A80H D-A73C/A80C D-F7□/D-J79 D-F7□V/D-J79C		D-A79W		D-F7□W D-F7BAL D-F7□F D-J79W D-F7□WV		D-A9□ D-A9□V		D-F□ D-F9□V		D-F9□W D-F9□WV D-F9BAL	
	A	B	A	B	A	B	A	B	A	B	A	B	A	B
32	15	10	15.5	10.5	12.5	7.5	19.5	14.5	14	9	18	13	17	12
40	18.5	13	19	13.5	16	10.5	23	17.5	17.5	12	21.5	16	20.5	15
50	16	16.5	16.5	17	13.5	14	20.5	21	15	15.5	19	19.5	18	18.5
63	18.5	19.5	19	20	16	17	23	24	17.5	18.5	21.5	22.5	20.5	21.5
80	21.5	24	22	24.5	19	21.5	26	28.5	20.5	23	24.5	27	23.5	26
100	24.5	30.5	25	31	22	28	29	35	23.5	29.5	27.5	33.5	26.5	32.5

Auto Switch Mounting Height

Bore size (mm)	D-A7□/A80	D-A7H□/A80H D-F7□/D-J79/D-F7□ W D-J79W/D-F7BAL D-F7□F/D-F7NTL	D-A73C D-A80C	D-F7□V D-F7□WV	D-J79C	D-A79W	D-A9□V	D-F9□V D-F9□WV	D-F9□W D-F9BAL
	U	U	U	U	U	U	U	U	U
32	31.5	32.5	38.5	35	38	34	27	29	26.5
40	35	36	42	38.5	41.5	37.5	30.5	32.5	30
50	41	42	48	44.5	47.5	43.5	36.5	38.5	36
63	47.5	48.5	54.5	51	54	50	40	42	39.5
80	57.5	58.5	64.5	61	64	60	50	52	49.5
100	67.5	68.5	74.5	71	74	70	60	62	59.5

Series CDQ2

ø32 to ø50 With Auto Switch

For those without auto switches, refer to the dimension chart because their A and B dimensions will differ.

Through-hole/CQ2BS, CDQ2BS

Both ends tapped: CQ2AS/CDQ2AS

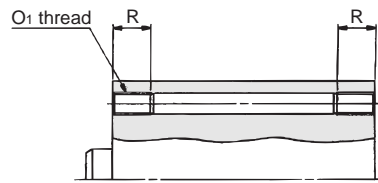

Both ends tapped (mm)

Bore (mm)	O1	R
32	M6 X 1.0	10
40	M6 X 1.0	10
50	M8 X 1.25	14

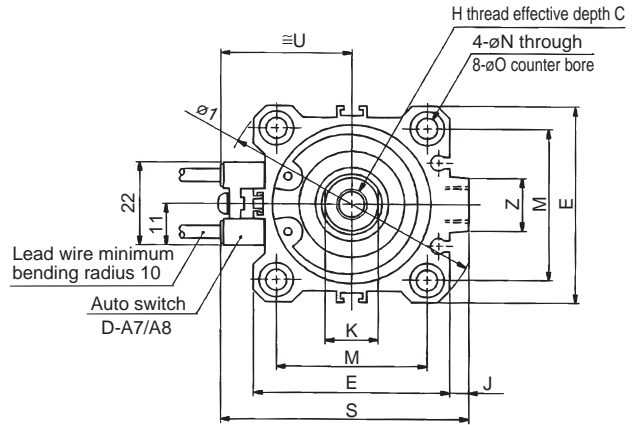
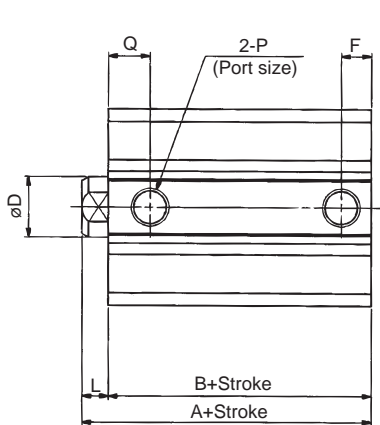

Rod end male thread

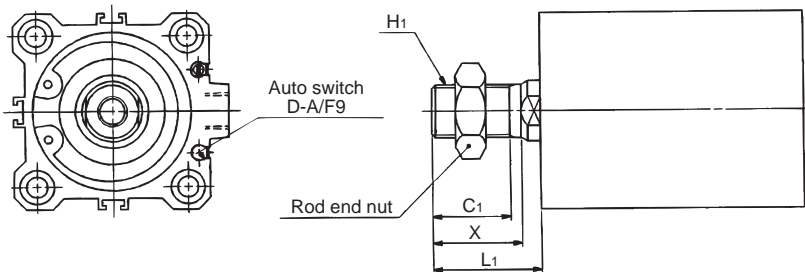

Rod end male thread (mm)

Bore (mm)	C1	X	H1	L1
32	20.5	23.5	M14 X 1.5	28.5
40	20.5	23.5	M14 X 1.5	28.5
50	26	28.5	M18 X 1.5	33.5

Bore (mm)	Stroke range (mm)	Without auto switch		With auto switch		C	D	E	F	H	I	J	K	L	M	N	O	P	Q	S	U	Z	
		A	B	A	B																		
		32	5 to 50	40	33																		50
	75, 100	50	43																				
40	5 to 50	46.5	39.5	56.5	49.5	13	16	52	8	M8 X 1.25	69	5	14	7	40	5.5	9 Depth 7	Rc(PT)1/8	11	66	35	14	
	75, 100	56.5	49.5																				
50	10 to 50	48.5	40.5	58.5	50.5	15	20	64	10.5	M10 X 1.5	86	7	17	8	50	6.6	11 Depth 8	Rc(PT)1/4	10.5	80	41	19	
	75, 100	58.5	50.5																				

Foot/CQ2L, CDQ2L

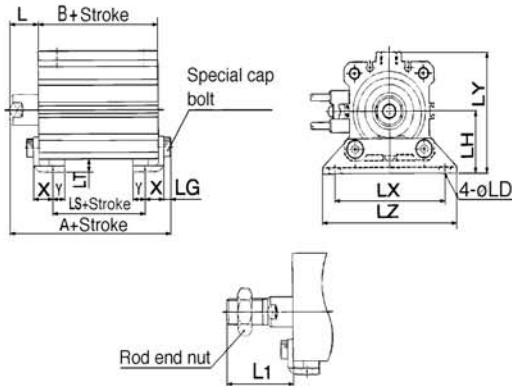

Front flange/CQ2F, CDQ2F

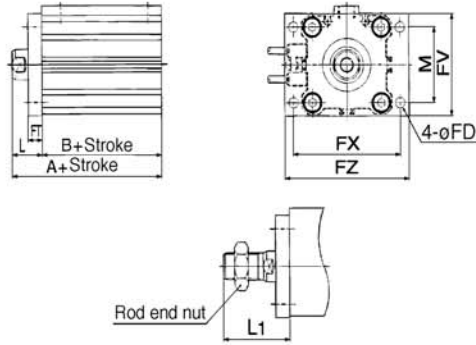

Rear flange/CQ2G, CDQ2G

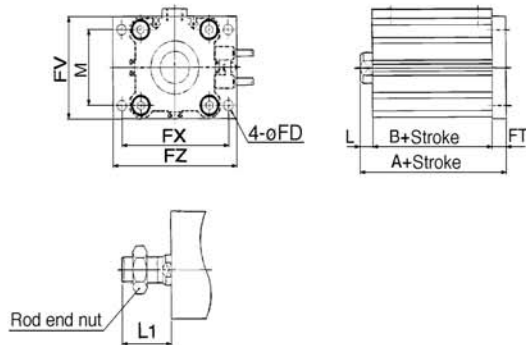

Double clevis/CQ2D, CDQ2D

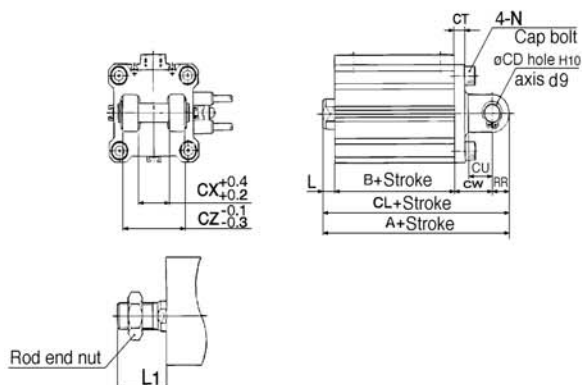

Foot (mm)

Bore (mm)	Stroke range (mm)	Without auto switch			With auto switch			L	L1	LD
		A	B	LS	A	B	LS			
32	5 to 50	57.2	33	17	67.2	43	27	17	38.5	6.6
	75, 100	67.2	43	27						
40	5 to 50	63.7	39.5	23.5	73.7	49.5	33.5	17	38.5	6.6
	75, 100	73.7	49.5	33.5						
50	10 to 50	66.7	40.5	17.5	76.7	50.5	27.5	18	43.5	9
	75, 100	76.7	50.5	27.5						

Bore (mm)	Stroke range (mm)	LG	LH	LT	LX	LY	LZ	X	X
32	5 to 50								
	75, 100	4	30	3.2	57	57	71	11.2	5.8
40	5 to 50								
	75, 100	4	33	3.2	64	64	78	11.2	7
50	10 to 50								
	75, 100	5	39	3.2	79	78	95	14.7	8

Front flange (mm)

Bore (mm)	Stroke range (mm)	W/o auto switch		W/ auto switch		L	L1	M
		A	B	A	B			
32	5 to 50	50	33	60	43			
	75, 100	60	43					
40	5 to 50	56.5	39.5	66.5	49.5			
	75, 100	66.5	49.5					
50	10 to 50	58.5	40.5	68.5	50.5			
	75, 100	68.5	50.5					

Bore (mm)	Stroke range (mm)	FD	FT	FV	FX	FZ	L	L1	M
32	5 to 50								
	75, 100	5.5	8	48	56	65	17	38.5	34
40	5 to 50								
	75, 100	5.5	8	54	62	72	17	38.5	40
50	10 to 50								
	75, 100	6.6	9	67	76	89	18	43.5	50

Rear flange (mm)

Bore (mm)	Stroke range (mm)	W/o auto switch	W auto switch	L	L1
		A	A		
32	5 to 50	48	58	7	28.5
	75, 100	58			
40	5 to 50	54.5	64.5	7	28.5
	75, 100	64.5			
50	10 to 50	57.5	67.5	8	33.5
	75, 100	67.5			

(*Dimensions except A, L and L1 are same as front flange type.)

Double clevis (mm)

Bore (mm)	Stroke range (mm)	Without auto switch			With auto switch			CD	CT
		A	B	CL	A	B	CL		
32	5 to 50	70	33	60	80	43	70	10	5
	75, 100	80	43	70					
40	5 to 50	78.5	39.5	68.5	88.5	49.5	78.5	10	6
	75, 100	88.5	49.5	78.5					
50	10 to 50	90.5	40.5	76.5	100.5	50.5	86.5	14	7
	75, 100	100.5	50.5	86.5					

Bore (mm)	Stroke range (mm)	CU	CW	CX	CZ	L	L1	N	RR
32	5 to 50								
	75, 100	14	20	18	36	7	28.5	M6 X 1.0	10
40	5 to 50								
	75, 100	14	22	18	36	7	28.5	M6 X 1.0	10
50	10 to 50								
	75, 100	20	28	22	44	8	33.5	M8 X 1.25	14

*Refer to p.2.3-18 & 19 for rod end nut and optional bracket.

*Clevis pin and snap ring are packed with the double clevis.

Series CDQ2

ø63 to ø100 With Auto Switch

For those without auto switches, refer to the dimension chart because their A and B dimensions will differ.

Through-hole/CQ2BS, CDQ2BS

Both ends tapped: CQ2AS/CDQ2AS

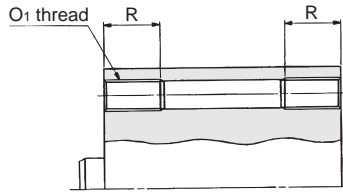

Both ends tapped (mm)

Bore (mm)	O1	R
63	M10 X 1.5	18
80	M12 X 1.75	22
100	M12 X 1.75	22

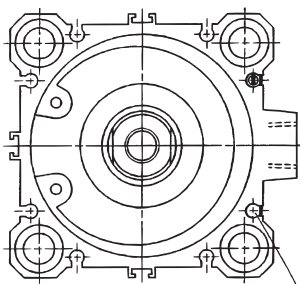
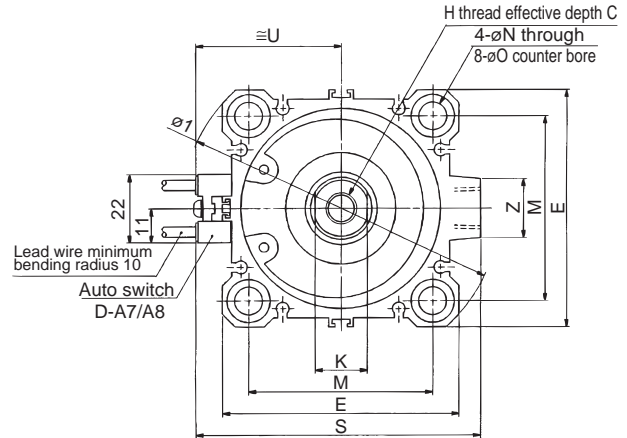
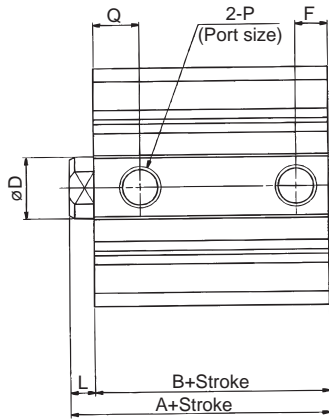

Rod end male thread

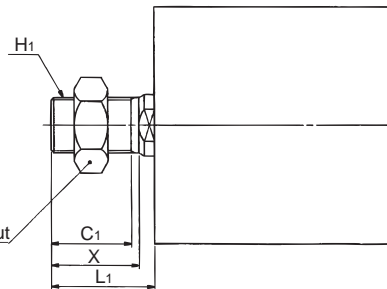

Rod end male thread (mm)

Bore (mm)	C1	X	H1	L1
63	26	28.5	M18 X 1.5	33.5
80	32.5	35.5	M22 X 1.5	43.5
100	32.5	35.5	M26 X 1.5	43.5

Bore (mm)	Stroke range (mm)	Without auto switch		With auto switch		C	D	E	F	H	I	J	K	L	M	N	O	P	Q	S	U	Z
		A	B	A	B																	
		(mm)																				
63	10 to 50	54	46	64	56	15	20	77	10.5	M10 X 1.5	103	7	17	8	60	9	14 Depth 10.5	Rc(PT)1/4	15	93	47.5	19
	75, 100	64	56																			
80	10 to 50	63.5	53.5	73.5	63.5	21	25	98	12.5	M16 X 2.0	132	6	22	10	77	11	17.5 Depth 13.5	Rc(PT)3/8	16	112.5	57.5	26
	75, 100	73.5	63.5																			
100	10 to 50	75	63	85	73	27	30	117	13	M20 X 2.5	156	6.5	27	12	94	11	17.5 Depth 13.5	Rc(PT)3/8	23	132.5	67.5	26
	75, 100	85	73																			

Foot/CQ2L, CDQ2L

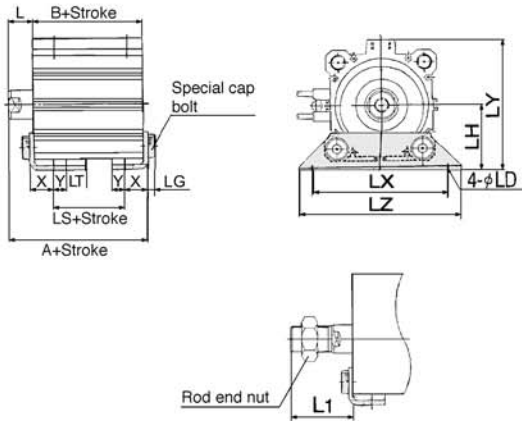

Foot

Bore (mm)	Stroke range (mm)	Without auto switch			With auto switch			(mm)	
		A	B	LS	A	B	LS	L	L1
63	10 to 50	72.2	46	20	82.2	56	30	18	43.5
	75, 100	82.2	56	30					
80	10 to 50	85	53.5	23.5	95	63.5	33.5	20	53.5
	75, 100	95	63.5	33.5					
100	10 to 50	98	63	29	108	73	39	22	53.5
	75, 100	108	73	39					

Bore (mm)	Stroke range (mm)	LD	LG	LH	LT	LX	LY	LZ	X	Y
63	10 to 50	11	5	46	3.2	95	91.5	113	16.2	9
	75, 100									
80	10 to 50	13	7	59	4.5	118	114	140	19.5	11
	75, 100									
100	10 to 50	13	7	71	6	137	136	162	23	12.5
	75, 100									

Front flange/CQ2F, CDQ2F

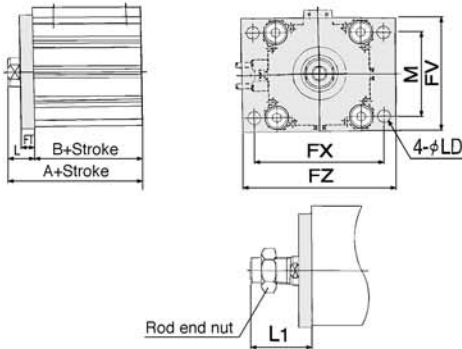

Front flange

Bore (mm)	Stroke range (mm)	W/o auto switch		W/ auto switch		(mm)							
		A	B	A	B	FD	FT	FV	FX	FZ	L	L1	M
63	10 to 50	64	46	74	56	9	9	80	92	108	18	43.5	60
	75, 100	74	56										
80	10 to 50	73.5	53.5	83.5	63.5	11	11	99	116	134	20	53.5	77
	75, 100	83.5	63.5										
100	10 to 50	85	63	95	73	11	11	117	136	154	22	53.5	94
	75, 100	95	73										

Rear flange/CQ2G, CDQ2G

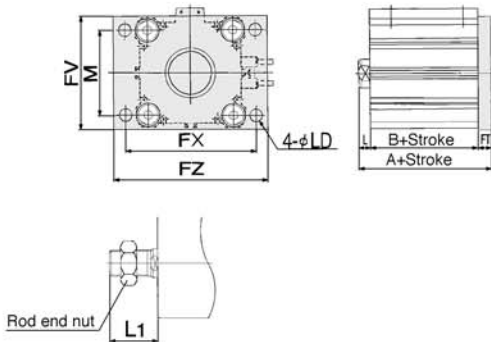

Rear flange

Bore (mm)	Stroke range (mm)	W/o auto switch		W/ auto switch		(mm)	
		A	A	L	L1		
63	10 to 50	63	73	8	33.5		
	75, 100	73					
80	10 to 50	74.5	84.5	10	43.5		
	75, 100	84.5					
100	10 to 50	86	96	12	43.5		
	75, 100	96					

(*Dimensions except A, L and L1 are same as front flange type.)

Double clevis/CQ2D, CDQ2D

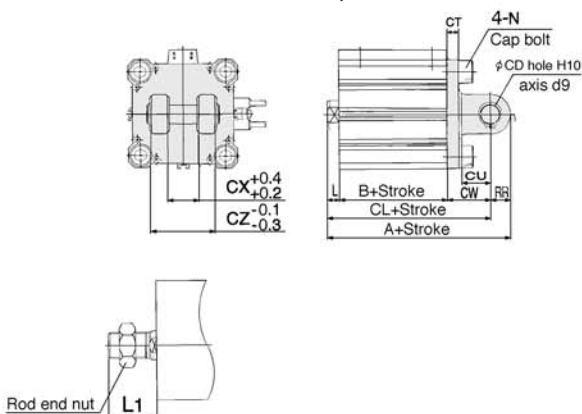

Double clevis

Bore (mm)	Stroke range (mm)	Without auto switch			With auto switch			(mm)									
		A	B	CL	A	B	CL	CD	CT	CU	CW	CX	CZ	L	L1	N	RR
63	10 to 50	98	46	84	108	56	94	14	8	20	30	22	44	8	33.5	M10 X 1.5	14
	75, 100	108	56	94													
80	10 to 50	119.5	53.5	101.5	129.5	63.5	111.5	18	10	27	38	28	56	10	43.5	M12 X 1.75	18
	75, 100	129.5	63.5	111.5													
100	10 to 50	142	63	120	152	73	130	22	13	31	45	32	64	12	43.5	M12 X 1.75	22
	75, 100	152	73	130													

*Refer to p.2.3-18 & 19 for rod nut and optional bracket.

*Clevis pin and snap ring are packed with the double clevis type.

CUJ

CU

CQS

CQ2

RQ

MU

