

Part number	Type-PG-size	Outer-diam. mm	Minimum-diam. over braid mm	Thread-length mm	PU pieces
SKINTOP® MS-SC					
5311 2210	MS-SC 9	3 - 8	4	6	50
5311 2220	MS-SC 11	4 - 10	4	6	50
5311 2230	MS-SC 13,5	5 - 12	4	6,5	25
5311 2240	MS-SC 16	8 - 14	6	6,5	25
5311 2250	MS-SC 21	11 - 17,5	8	7	25
5311 2260	MS-SC 29	16 - 25	13	8	10
5311 2270	MS-SC 36	19 - 32	16	15	5
SKINTOP® MS-SC XL					
5311 2310	MS-SC XL 9	3 - 8	4	12	50
5311 2320	MS-SC XL 11	4 - 10	4	12	50
5311 2330	MS-SC XL 13,5	5 - 12	4	12	25
5311 2340	MS-SC XL 16	8 - 14	6	12	25
5311 2350	MS-SC XL 21	11 - 17,5	8	12	25
5311 2360	MS-SC XL 29	16 - 25	13	15	10

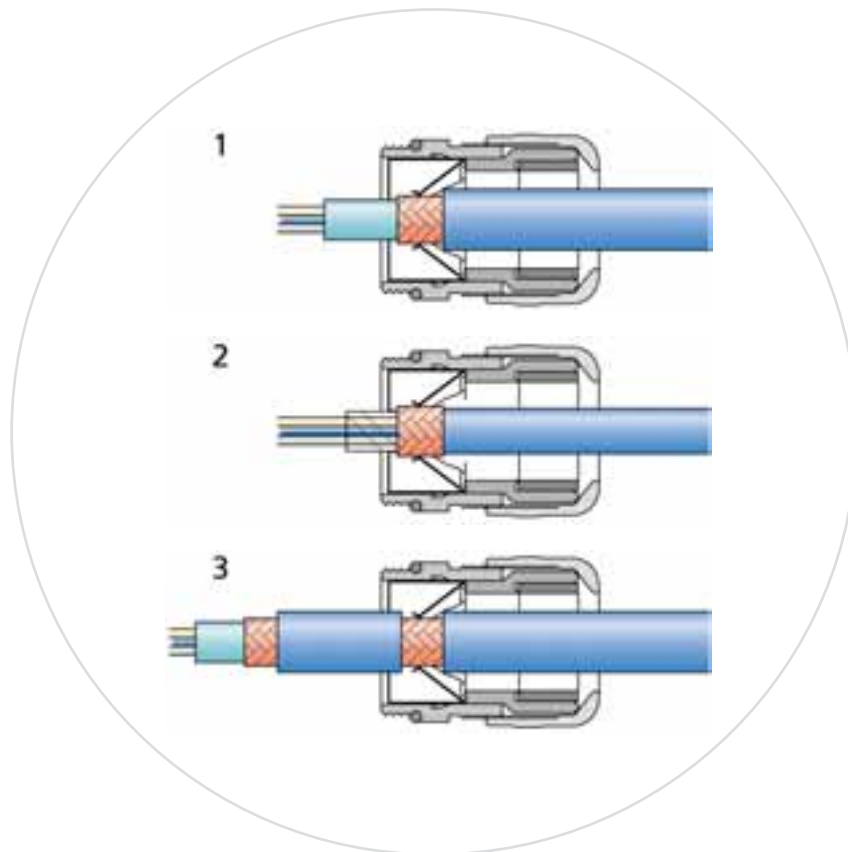

SKINTOP® MS-SC

Easy-to-mount EMC-safe cable gland

SKINTOP® MS-SC

The SKINTOP® MS-SC Screen Connection is the ideal gland for all copper-screened cables. The widely variable clamping ranges greatly simplify mounting and allocation and thus permit economic storage. The SKINTOP® MS-SC looks like a normal gland, but contacts the screen much more rapidly than any other system. With the SKINTOP® MS-SC the cable is centralized, attached, strain-relieved and hermetically sealed (IP 68). Introduce the cable ensuring that the screening braid is in the contacting spring and turn. With the SKINTOP® MS-SC the cable screening braid not only provides mechanical strength, but also helps achieve an optimum low-resistance screen contact.

SKINTOP® MS-SC XL long connection thread

Additionally we offer our proven SKINTOP® MS-SC with long connection thread, PG 9-21 with 12 mm and PG 29 with 15 mm for thick wall housings.

Note

For painted, eloces or powdered cabinet coab, you need for best contact our EMC counter nut with cutting edges SKINDICHT® SM-PE. Further suitable accessories see SKINDICHT® SM page 9.117 SKINDICHT® SM-PE page 9.117.

1. With the standard contacting

- Strip back the outer sheath and screen
- Make a round cut in the outer sheath approx. 15 mm, but do not remove the sheath
- Guide the cable through the cable gland
- Pull off the outer sheath
- Pull back the cable until the connection is made between the cable screen and contact spring
- Turn to shut ... and it is ready for use!

2. With thin wires without an inner sheath

- Strip back the outer sheath
- Pull back the screen braid approx. 15-20 mm over the outer sheath
- Insert the cables into the cable gland until the contact is made between the cable screen and contact spring
- Turn to shut ... and it is ready for use!

3. When routing the cable screen to another connection

- Expose the screen braid approx. 10 mm
- Guide the cable through the cable gland until the connection is made between the cable screen and contact spring
- Turn to shut ... and it is ready for use!

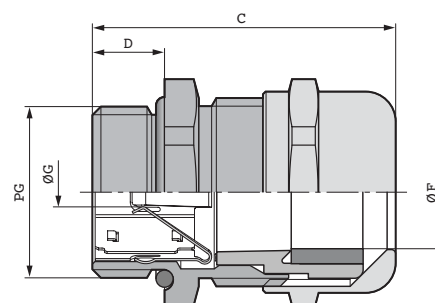
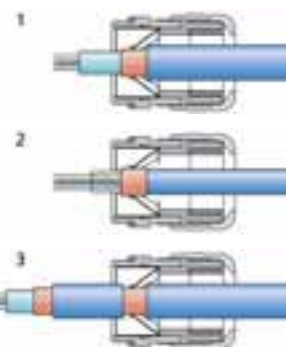

Technical Data

Material:

Temperature range:

Protection class:

Note:

Attention

SKINTOP® MS-SC

Body: Brass, nickel-plated
Insert: polyamide
Sealing ring: CR/NBR
O-ring: NBR

-30 °C to +100 °C

IP 68

Data sheet on request

Installation dimensions and tightening torque values see T21 a+b

Optimized screening

Article by Dr.-Ing. U. Bochler and Dipl.-Ing. M. Jacobsen
EMC problems with the use of cable glands

In industrial environments, motors, controls and automatic welding machines can seriously impair electromagnetic compatibility (EMC). Particular problems are caused in industrial installations by long cable runs for power supply or data transmission between individual components; appropriate preventive measures are therefore essential.

Due to the antenna radiation effect of such cables, radio interference can be picked up and the useful signal (for example, temperature sensor or shaft encoder) blanketed. Result: functional disturbances of the connected equipment – from undetected false readings to the breakdown of an entire production line. Conversely, cables can function as transmitters causing radio interference. Installation of electronic components in an earthed switch cabinet and the simultaneous use of screened cables has proved to be an effective countermeasure. In practice, however, the location of the cable duct frequently constitutes a weak point in the switch cabinet. Insufficient contact between the cable screening and the metal housing often destroys the desired screening effect. It is here that the SKINTOP® and SKINDICHT® cable glands from Lapp prove their worth. The newly developed SKINTOP® MS-SC in particular is distinguished by its excellent EMC characteristics in addition to ease of handling. It enables the use of various different cable designs within a large diameter range.

Screening concepts

With the interference phenomena typically found in the industrial environment, we must distinguish principally between cable-linked and field-linked interference. Field-linked interference emissions which, for example, are radiated directly from a circuit board or, conversely, exercise an effect upon it, can be effectively checked by installing electrical or electronic assemblies in closed metal housings such as switch cabinets. If the housing does not have any particularly large apertures, a Faraday shield is produced which affords efficient protec-

tion against electromagnetic interferences. In practice, this type of screening is generally extremely expensive and is hardly practicable in the case of moving machine components. An alternative solution is provided by cables with screening braid. In this case, the quality of the screen effect depends to a great extent on the texture and thickness of the braiding. In addition, optimum attachment of the the cable screening to the housing must be ensured by suitable mechanical elements in order to prevent penetration of the interference conducted on the cable screening. Of decisive importance is the derivation resistance, i.e. the resistance which a guide wave „sees“ upon the cable screening when it meets the point of intersection cable / housing.

Practical requirements

Thus, in terms of EMC, we have a series of practical requirements for optimum contact:

- The connection between the cable screening and the housing potential must be of low impedance. To ensure this, the contact surfaces must be as large as possible. Under ideal conditions the cable screening, together with the housing wall, constitute a closed connection and form a continuation of the housing, without permitting any openings to be formed.
- The connection must be of low induction. This means that the cable screening must be led to the housing wall via the shortest possible path and with the widest possible cross-section. Preferably a type of contact should be chosen which completely surrounds the internal conductor. The procedure frequently practised, namely first leading the cable into the housing and placing the screening somewhere inside the housing, whereby the screen braiding is often extended by means of a thin cable strand, makes effective screening almost impossible.
- For practical application, simplicity of handling and instal-

lation are desirable. An electrician must be able to carry out installation without difficulty.

SKINTOP® and SKINDICHT®

The cable glands SKINTOP® and SKINDICHT® guarantee, in addition to perfect mechanical contact, the necessary low impedance and low induction connection. These glands, which are simple to install, are available in different versions and sizes. With SKINDICHT® SHVE, the cable screen is pressed between an earthing sleeve and a conical seal, thus permitting all-round contact over a wide area. In the case of SKINTOP® MS-SC, the contact is produced by means of cylindrically arranged contact springs. Only the cable sheathing in the area of the contact springs must be removed, and it is not necessary to open the screen braiding.

For the sake of clarity, this article focuses upon the cable gland SKINTOP® MS-SC. In a number of tests, excellent screening properties were demonstrated. Since the appropriate standard for cable glands does not define a particular set-up of test equip-

ment, two possible measuring procedures and their evaluation are described below:

Derivation impedance, derivation attenuation: as a characteristic quantity for evaluating the quality of a cable connection to the wall of the housing (reference potential), the derivation resistance RA is documented via the frequency. This provides information as to what extent charges on the cable screening can be derived against the potential of the housing. To determine the screen attenuation factor of a cable, the derivation attenuation is calculated: the potential at the derivation resistance is related to the maximum available potential in a 50 W reference system. The derivation attenuation is obtained as follows:

$$\alpha_A \text{ (in dB)} = 20 \log (2RA / (2RA + 50 \text{ W})).$$

Triaxial Method: In the Triaxial Method, measurement is carried out in accordance with the German Defence Equipment Standard VG 95373 Pt 40 or 41. These set-ups, using a coaxial structure in a graduated tube (hence the term triaxial), are designed for a male / female

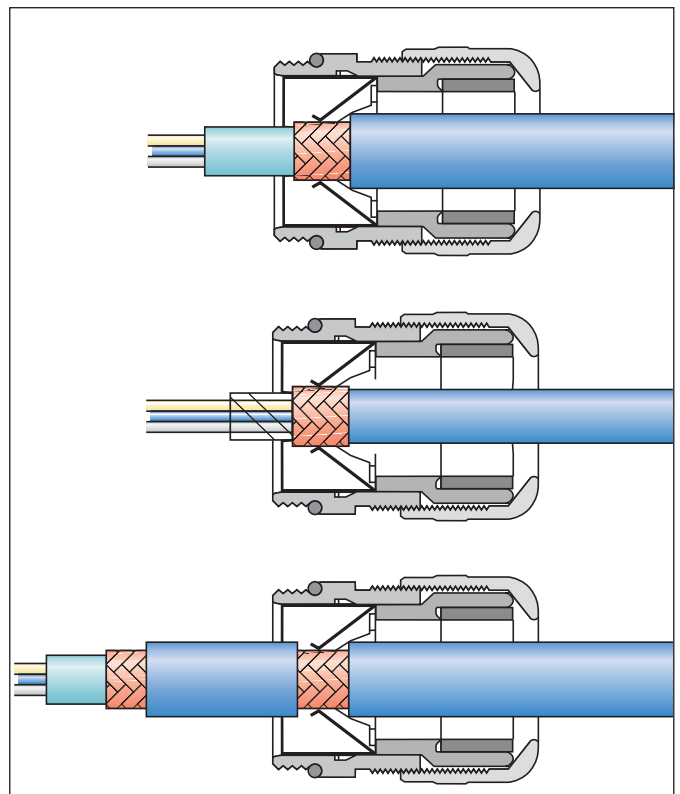

	Triaxial Method	Measurement of the derivation impedance
Application	Pairs of connectors and screened cables	Cable glands
Measurement	Screen attenuation mass from which the interaction impedance is calculated	Derivation impedance is determined directly
Reference to later application	Description of the screening efficiency: how effectively is the re-radiation of irradiation suppressed by field-linked interferences.	Description of how effectively interferences on the screening can be derived to an earthing mass (e.g. wall of switch cabinet)

socket pair, or employ a piece of cable of defined length for the purpose of qualifying a cable. The values of the screen attenuation mass a_S and the coupling impedance Z_K are determined for evaluation of the screening effect of the connectors depending upon their material characteristics and their construction, according to the formula:

$$AS = 20 \log(50 W / ZK).$$

A precondition for measurement according to these standards is a solid sheathing of the supply cable used (generally by means of a tube). However, this results in screen attenuation values of almost 100 dB; for practical applications on a switch cabinet wall, depending upon the conditions, these can be achieved only with difficulty or not at all.

Comparison of both methods: In order to provide by means of the measured values a description of practical use of the a/m products, the measurement procedure of the derivation impedance and conversion into screen attenuation have been used (see Table)

Measurement Results

Measurements were made upon glands of type Skintop MS-SC in various sizes with screened cables Öflex CY in diameters of

6 – 22 mm, by both methods, in order to test and compare the validity of the results for cable glands obtained by each method.

Measuring the derivation impedance: in order to determine the derivation impedance, the cable glands were in each case connected to a piece of cable of approx. 10 cm length. At frequencies up to 10 MHz, all glands reveal a derivation impedance of <1W. This results in attenuation values of 30 – 50 dB (assuming a 50 W reference system). The amplitudes of high-frequency spurious components which are located in this frequency range are thus reduced at least by the factor 30, maximum by the factor 300. Only at frequencies above 3 – 4 MHz does the achievable attenuation sink to values <40 db (factor 100). At higher frequencies (100 MHz), derivation impedance values in the range of 5 – 10 W are obtained. The measurement values

confirm the assumed favourable EMC characteristics. Even up to high frequencies, low derivation impedance – or high derivation attenuation values can be obtained. Thus together with effective cable screening, optimum protection against cable-conducted interference signals can be achieved.

Triaxial measurement:

Measurements were performed as described above, in accordance with the German Defence Equipment Standard VG 95373, Procedure KS 01 B. The DC resistance of the glands equals 1 mW; this produces screening attenuation values which, depending upon the size and type of the gland, can amount to >100 dB.

Comparison of results: The results reveal a clear difference between derivation attenuation and the screening attenuation in a system with identical components cable / gland. The curve for derivation attenuation is shifted upwards by approx. 40 dB almost parallel to the screening attenuation curve, i.e. shifted to lower attenuation values.

Nevertheless, these values are more meaningful with regard to cable-conducted interference, because in reality, attenuation values of between 80 and 100 dB can hardly be achieved.

Conclusion

The different measurement methods give different values for the attenuation rate and, with these values, different characteristics are expressed. On the one hand, the value „screening attenuation” expresses how effectively the re-radiation or the irradiation is suppressed by field-linked interferences (Triaxial Method); the value „derivation attenuation”, on the other hand, expresses how effectively interferences on the screening can be derived to an earthing mass (measurement of derivation impedance). This means that attenuation values cannot be simply compared without reservation. It can however be assumed that values for „derivation attenuation” are more meaningful for glands, because the results of the Triaxial Method (screen attenuation) are dependent on the screening of the supply cable used.

