

ECN Symbol	ECN No.	Descriptions	Date
			July 2003

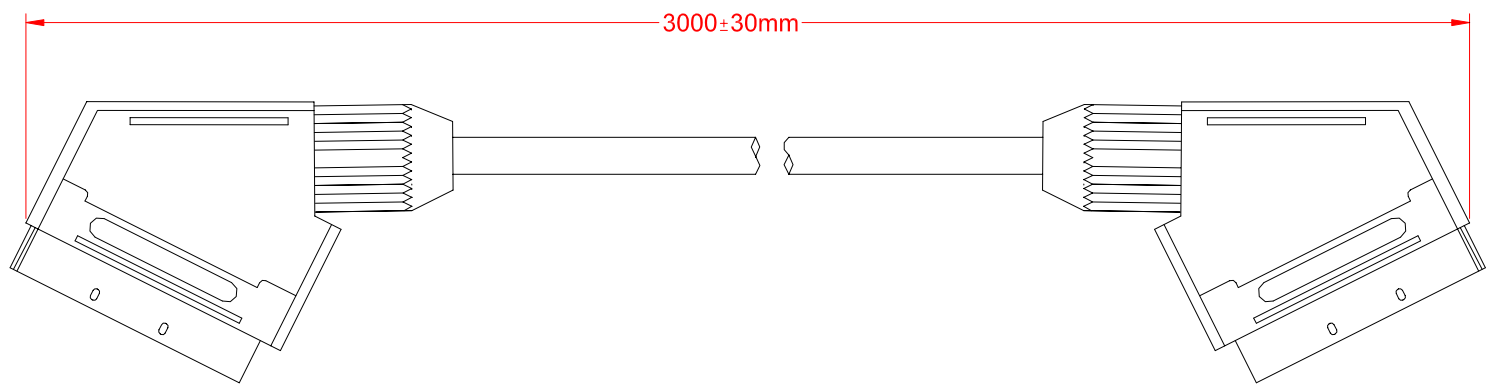

CRIMP TYPE 21PIN(P-P)

SECTION

WIRING DIAGRAM

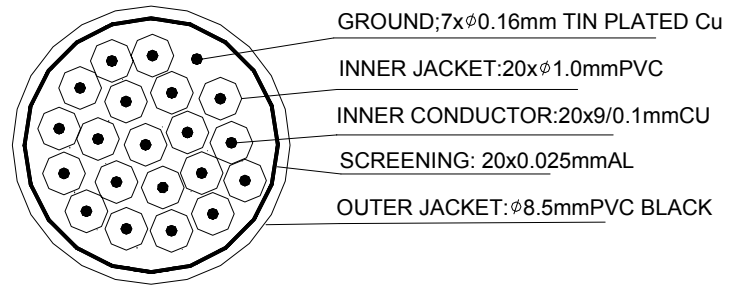
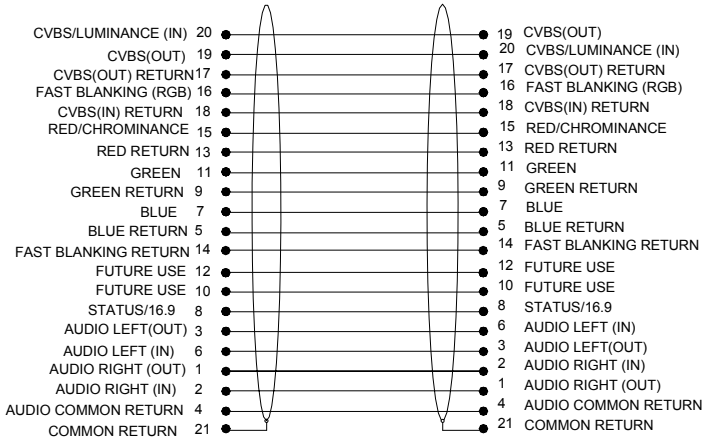

Prepared	Neil Tang	Material		Scart(p) to Scart(p)
Checked		Finish		Model
Approved		Q'ty	VER.	Scale
Unit mm			A-1	Parts
Ref/No.		Page		JESMAY

Model AVVCL16

JESMAY