

December 1993

10-Bit, 12-Bit Multiplying D/A Converters

Features

- AD7520/AD7530 10 Bit Resolution; 8, 9 and 10 Bit Linearity
- AD7521/AD7531 12 Bit Resolution; 8, 9 and 10 Bit Linearity
- Low Power Dissipation of 20mW (Max)
- Low Nonlinearity Tempco at 2ppm of FSR/°C
- Current Settling Time 1.0μs to 0.05% of FSR
- ±5V to +15V Supply Voltage Range
- TTL/CMOS Compatible
- Full Input Static Protection
- /883B Processed Versions Available

Description

The AD7520/AD7530 and AD7521/AD7531 are monolithic, high accuracy, low cost 10-bit and 12-bit resolution, multiplying digital-to-analog converters (DAC). Harris' thin-film on CMOS processing gives up to 10-bit accuracy with TTL/CMOS compatible operation. Digital inputs are fully protected against static discharge by diodes to ground and positive supply.

Typical applications include digital/analog interfacing, multiplication and division, programmable power supplies, CRT character generation, digitally controlled gain circuits, integrators and attenuators, etc.

The AD7530 and AD7531 are identical to the AD7520 and AD7521, respectively, with the exception of output leakage current and feedthrough specifications.

Ordering Information

| PART NUMBER | NONLINEARITY | TEMPERATURE RANGE | PACKAGE |
|-------------------------|----------------|-------------------|---------------------|
| AD7520JN, AD7530JN | 0.2% (8-Bit) | 0°C to +70°C | 16 Lead Plastic DIP |
| AD7520KN, AD7530KN | 0.1% (9-Bit) | 0°C to +70°C | 16 Lead Plastic DIP |
| AD7521JN, AD7531JN | 0.2% (8-Bit) | 0°C to +70°C | 18 Lead Plastic DIP |
| AD7521KN, AD7531KN | 0.1% (9-Bit) | 0°C to +70°C | 18 Lead Plastic DIP |
| AD7520LN, AD7530LN | 0.05% (10-Bit) | -40°C to +85°C | 16 Lead Plastic DIP |
| AD7521LN, AD7531LN | 0.05% (10-Bit) | -40°C to +85°C | 18 Lead Plastic DIP |
| AD7520JD | 0.2% (8-Bit) | -25°C to +85°C | 16 Lead Ceramic DIP |
| AD7520KD | 0.1% (9-Bit) | -25°C to +85°C | 16 Lead Ceramic DIP |
| AD7520LD | 0.05% (10-Bit) | -25°C to +85°C | 16 Lead Ceramic DIP |
| AD7520SD, AD7520SD/883B | 0.2% (8-Bit) | -55°C to +125°C | 16 Lead Ceramic DIP |
| AD7520TD | 0.1% (9-Bit) | -55°C to +125°C | 16 Lead Ceramic DIP |
| AD7520UD, AD7520UD/883B | 0.05% (10-Bit) | -55°C to +125°C | 16 Lead Ceramic DIP |

Pinouts

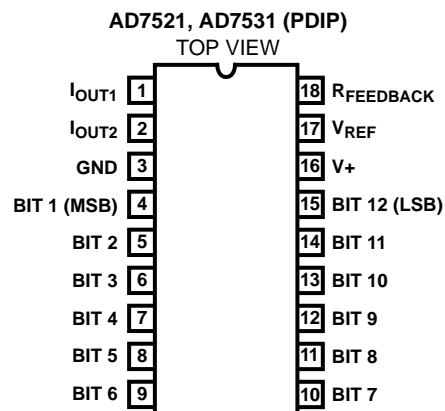
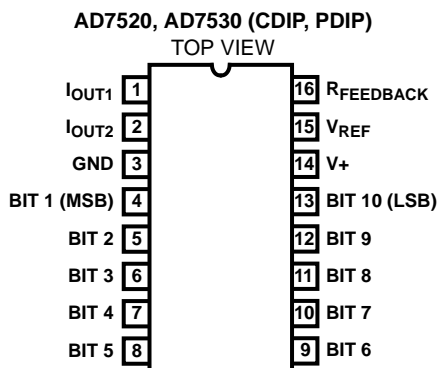

Specifications AD7520, AD7530, AD7521, AD7531

Absolute Maximum Ratings

| | |
|---------------------------------------|-----------------|
| Supply Voltage (V+ to GND)..... | +17V |
| V _{REF} | ±25V |
| Digital Input Voltage Range | V+ to GND |
| Output Voltage Compliance | -100mV to V+ |
| Storage Temperature | -65°C to +150°C |
| Lead Temperature (Soldering 10s)..... | 300°C |

Thermal Information

| | | |
|---------------------------|------------------------------|---------------|
| Thermal Resistance | θ_{JA} | θ_{JC} |
| 16 Lead Plastic DIP | 100°C/W | - |
| 18 Lead Plastic DIP | 90°C/W | - |
| 16 Lead Ceramic DIP | 80°C/W | 24°C/W |
| Maximum Power Dissipation | | |
| Up to +75°C..... | 450mW | |
| | Derate Above +75°C at 6mW/°C | |
| Operating Temperature | | |
| JN, KN, LN Versions | 0°C to +70°C | |
| JD, KD, LD Versions | -25°C to +85°C | |
| SD, TD, UD Versions | -55°C to +125°C | |

CAUTION: Stresses above those listed in "Absolute Maximum Ratings" may cause permanent damage to the device. This is a stress only rating and operation of the device at these or any other conditions above those indicated in the operational sections of this specification is not implied.

The digital control inputs are zener protected; however, permanent damage may occur on unconnected units under high energy electrostatic fields. Keep unused units in conductive foam at all times.

Do not apply voltages higher than V_{DD} or less than GND potential on any terminal except V_{REF} and R_{FEEDBACK}.

Electrical Specifications V+ = +15V, V_{REF} = +10V, T_A = +25°C Unless Otherwise Specified

| PARAMETER | TEST CONDITIONS | AD7520/AD7530 | | | AD7521/AD7531 | | | UNITS | |
|---|--|--|-----|------|----------------|-------------------|------|-------------------|-------------------|
| | | MIN | TYP | MAX | MIN | TYP | MAX | | |
| SYSTEM PERFORMANCE (Note 1) | | | | | | | | | |
| Resolution | | 10 | 10 | 10 | 12 | 12 | 12 | Bits | |
| Nonlinearity | J, S | S Over -55°C to +125°C (Notes 2, 5) (Figure 2) | | - | - | ±0.2 (8-Bit) | - | ±0.2 (8-Bit) | % of FSR |
| | K, T | T Over -55°C to +125°C (Figure 2) | | - | - | ±0.1 (9-Bit) | - | ±0.1 (9-Bit) | % of FSR |
| | L, U | -10V ≤ V _{REF} ≤ +10V U Over -55°C to +125°C (Figure 2) | | - | - | ±0.05 (10-Bit) | - | ±0.05 (10-Bit) | % of FSR |
| Nonlinearity Tempco | -10V ≤ V _{REF} ≤ +10V (Notes 2, 3) | | - | - | ±2 | - | - | ±2 | ppm of FSR/°C |
| Gain Error | | | - | ±0.3 | - | - | ±0.3 | - | % of FSR |
| Gain Error Tempco | | | - | - | ±10 | - | - | ±10 | ppm of FSR/°C |
| Output Leakage Current (Either Output) | Over the Specified Temperature Range | | - | - | ±200 (±300) | - | - | ±200 (±300) | nA |
| DYNAMIC CHARACTERISTICS | | | | | | | | | |
| Output Current Settling Time | To 0.05% of FSR (All Digital Inputs Low To High And High To Low) (Note 3) (Figure 7) | | - | 1.0 | - | - | 1.0 | - | µs |
| Feedthrough Error | V _{REF} = 20V _{p-p} , 10kHz (50kHz) All Digital Inputs Low (Note 3) (Figure 6) | | - | - | 10 | - | - | 10 | mV _{p-p} |
| REFERENCE INPUT | | | | | | | | | |
| Input Resistance | All Digital Inputs High I _{OUT1} at Ground | | 5 | 10 | 20 | 5 | 10 | 20 | kΩ |
| ANALOG OUTPUT | | | | | | | | | |
| Output Capacitance | I _{OUT1} | All Digital Inputs High (Note 3) (Figure 5) | - | 200 | - | - | 200 | - | pF |
| | I _{OUT2} | | - | 75 | - | - | 75 | - | pF |
| | I _{OUT1} | All Digital Inputs Low (Note 3) (Figure 5) | - | 75 | - | - | 75 | - | pF |
| | I _{OUT2} | | - | 200 | - | - | 200 | - | pF |

Specifications AD7520, AD7530, AD7521, AD7531

Electrical Specifications $V_+ = +15V$, $V_{REF} = +10V$, $T_A = +25^\circ C$ Unless Otherwise Specified (Continued)

| PARAMETER | TEST CONDITIONS | AD7520/AD7530 | | | AD7521/AD7531 | | | UNITS |
|------------------------------------|---|----------------------|----------------------------|---------|---------------|----------------------------|---------|----------------------|
| | | MIN | TYP | MAX | MIN | TYP | MAX | |
| Output Noise | Both Outputs (Note 3) (Figure 4) | - | Equivalent to 10k Ω | - | - | Equivalent to 10k Ω | - | Johnson Noise |
| DIGITAL INPUTS | | | | | | | | |
| Low State Threshold, V_{IL} | Over the Specified Temperature Range $V_{IN} = 0V$ or $+15V$ | - | - | 0.8 | - | - | 0.8 | V |
| High State Threshold, V_{IH} | | 2.4 | - | - | 2.4 | - | - | V |
| Input Current, I_{IL} , I_{IH} | | - | - | ± 1 | - | - | ± 1 | μA |
| Input Coding | See Tables 1 & 2 | Binary/Offset Binary | | | | | | |
| POWER SUPPLY CHARACTERISTICS | | | | | | | | |
| Power Supply Rejection | $V_+ = 14.5V$ to $15.5V$ (Note 2) (Figure 3) | - | ± 0.005 | - | - | ± 0.005 | - | % FSR/% ΔV_+ |
| Power Supply Voltage Range | | +5 to +15 | | | +5 to +15 | | | V |
| I_+ | All Digital Inputs at 0V or V_+ Excluding Ladder Network | - | ± 1 | - | - | ± 1 | - | μA |
| | All Digital Inputs High or Low Excluding Ladder Network | - | - | 2 | - | - | 2 | mA |
| Total Power Dissipation | Including the Ladder Network | - | 20 | - | - | 20 | - | mW |

NOTES:

1. Full scale range (FSR) is 10V for Unipolar and $\pm 10V$ for Bipolar modes.
2. Using internal feedback resistor $R_{FEEDBACK}$.
3. Guaranteed by design, or characterization and not production tested.
4. Accuracy not guaranteed unless outputs at GND potential.
5. Accuracy is tested and guaranteed at $V_+ = 15V$ only.

Functional Diagram

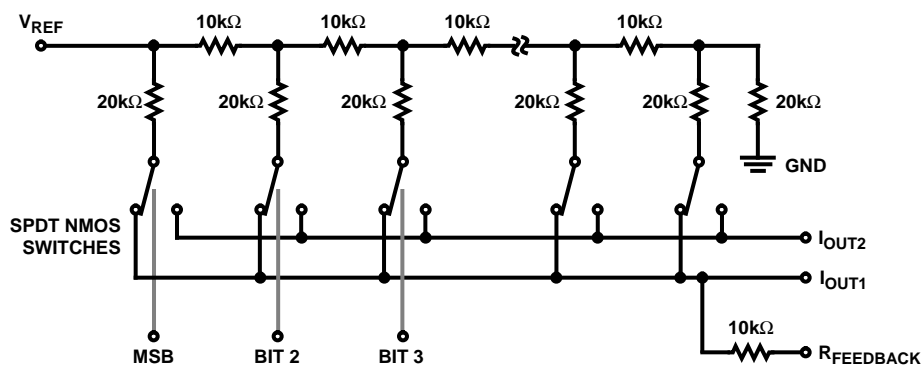

Switches shown for Digital Inputs "High".

Resistor values are typical.

Pin Descriptions

| AD7520/30 | AD7521/31 | PIN NAME | DESCRIPTION |
|-----------|-----------|-----------------------|---|
| 1 | 1 | I _{OUT1} | Current Out summing junction of the R2R ladder network. |
| 2 | 2 | I _{OUT2} | Current Out virtual ground, return path for the R2R ladder network |
| 3 | 3 | GND | Digital Ground. Ground potential for digital side of D/A. |
| 4 | 4 | Bits 1(MSB) | Most Significant Digital Data Bit |
| 5 | 5 | Bit 2 | Digital Bit 2 |
| 6 | 6 | Bit 3 | Digital Bit 3 |
| 7 | 7 | Bit 4 | Digital Bit 4 |
| 8 | 8 | Bit 5 | Digital Bit 5 |
| 9 | 9 | Bit 6 | Digital Bit 6 |
| 10 | 10 | Bit 7 | Digital Bit 7 |
| 11 | 11 | Bit 8 | Digital Bit 8 |
| 12 | 12 | Bit 9 | Digital Bit 9 |
| 13 | 13 | Bit 10 | Digital Bit 10 (AD7521/31), Least Significant Digital Data Bit (AD7520/30) |
| - | 14 | Bit 11 | Digital Bit 11 (AD7521/31) |
| - | 15 | Bit 12 | Least Significant Digital Data Bit (AD7521/31) |
| 14 | 16 | V+ | Power Supply +5 to +15 Volts |
| 15 | 17 | V _{REF} | Voltage Reference Input to set the output range. Supplies the R2R resistor ladder. |
| 16 | 18 | R _{FEEDBACK} | Feedback resistor used for the current to voltage conversion when using an external OP-Amp. |

Definition of Terms

Nonlinearity: Error contributed by deviation of the DAC transfer function from a "best straight line" through the actual plot of transfer function. Normally expressed as a percentage of full scale range or in (sub)multiples of 1 LSB.

Resolution: It is addressing the smallest distinct analog output change that a D/A converter can produce. It is commonly expressed as the number of converter bits. A converter with resolution of n bits can resolve output changes of 2^{-N} of the full-scale range, e.g. $2^{-N} V_{REF}$ for a unipolar conversion. Resolution by no means implies linearity.

Settling Time: Time required for the output of a DAC to settle to within specified error band around its final value (e.g. 1/2 LSB) for a given digital input change, i.e. all digital inputs LOW to HIGH and HIGH to LOW.

Gain Error: The difference between actual and ideal analog output values at full-scale range, i.e. all digital inputs at HIGH state. It is expressed as a percentage of full-scale range or in (sub)multiples of 1 LSB.

Feedthrough Error: Error caused by capacitive coupling from V_{REF} to I_{OUT1} with all digital inputs LOW.

Output Capacitance: Capacitance from I_{OUT1}, and I_{OUT2} terminals to ground.

Output Leakage Current: Current which appears on I_{OUT1}, terminal when all digital inputs are LOW or on I_{OUT2} terminal when all digital inputs are HIGH.

Detailed Description

The AD7520, AD7530, AD7521 and AD7531 are monolithic, multiplying D/A converters. A highly stable thin film R-2R resistor ladder network and NMOS SPDT switches form the basis of the converter circuit, CMOS level shifters permit low

power TTL/CMOS compatible operation. An external voltage or current reference and an operational amplifier are all that is required for most voltage output applications.

A simplified equivalent circuit of the DAC is shown in the Functional Diagram. The NMOS SPDT switches steer the ladder leg currents between I_{OUT1} and I_{OUT2} buses which must be held either at ground potential. This configuration maintains a constant current in each ladder leg independent of the input code.

Converter errors are further reduced by using separate metal interconnections between the major bits and the outputs. Use of high threshold switches reduce offset (leakage) errors to a negligible level.

The level shifter circuits are comprised of three inverters with positive feedback from the output of the second to the first, see Figure 1. This configuration results in TTL/CMOS compatible operation over the full military temperature range. With the ladder SPDT switches driven by the level shifter, each switch is binarily weighted for an ON resistance proportional to the respective ladder leg current. This assures a constant voltage drop across each switch, creating equipotential terminations for the 2R ladder resistors and highly accurate leg currents.

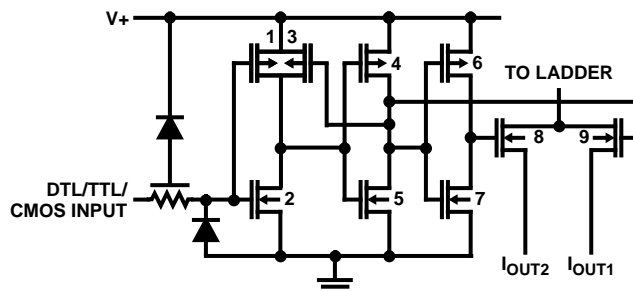

FIGURE 1. CMOS SWITCH

Test Circuits The following test circuits apply for the AD7520. Similar circuits are used for the AD7530, AD7521 and AD7531.

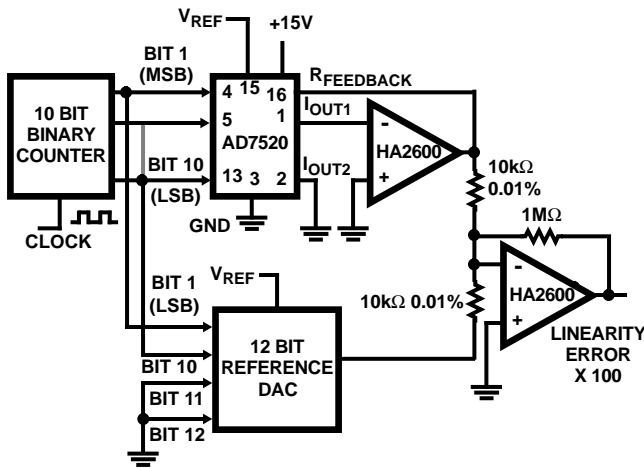

FIGURE 2. NONLINEARITY

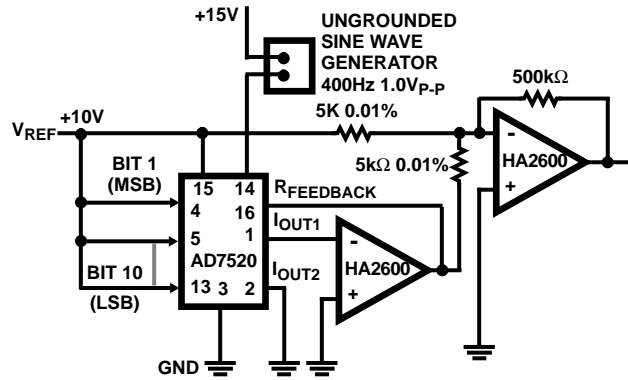

FIGURE 3. POWER SUPPLY REJECTION

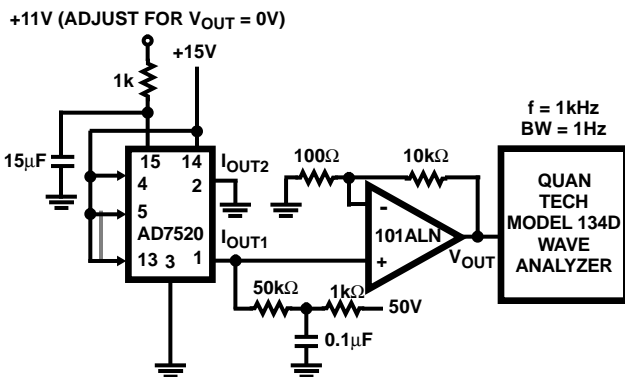

FIGURE 4. NOISE

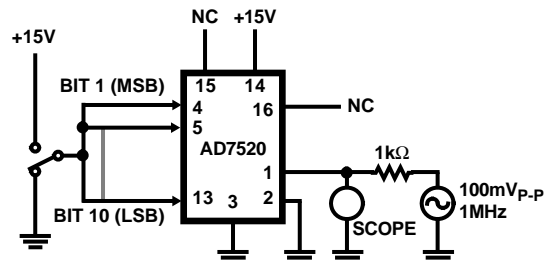

FIGURE 5. OUTPUT CAPACITANCE

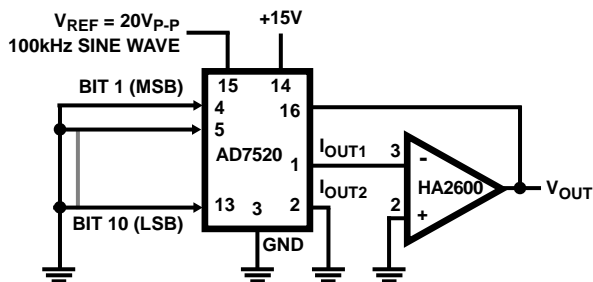

FIGURE 6. FEEDTHROUGH ERROR

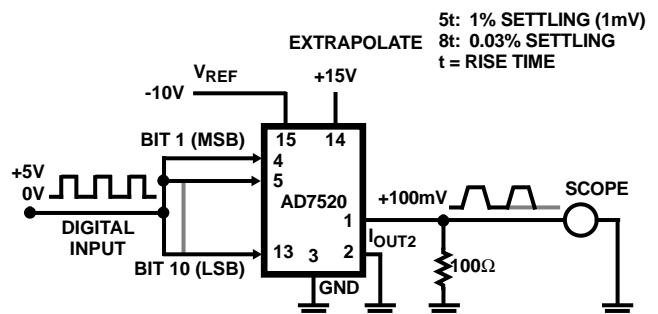

FIGURE 7. OUTPUT CURRENT SETTLING TIME

Applications

Unipolar Binary Operation

The circuit configuration for operating the AD7520 in unipolar mode is shown in Figure 8. Similar circuits can be used for AD7521, AD7530 and AD7531. With positive and negative V_{REF} values the circuit is capable of 2-Quadrant multiplication. The "Digital Input Code/Analog Output Value" table for unipolar mode is given in Table 1.

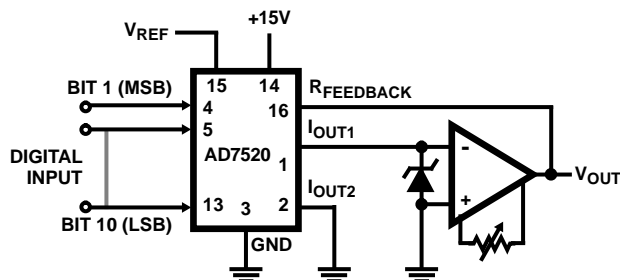

FIGURE 8. UNIPOLAR BINARY OPERATION (2-QUADRANT MULTIPLICATION)

TABLE 1. CODE TABLE - UNIPOLAR BINARY OPERATION

| DIGITAL INPUT | ANALOG OUTPUT |
|---------------|-----------------------------------|
| 1111111111 | $-V_{REF} (1-2^{-N})$ |
| 1000000001 | $-V_{REF} (\frac{1}{2} + 2^{-N})$ |
| 1000000000 | $-V_{REF}/2$ |
| 0111111111 | $-V_{REF} (\frac{1}{2} - 2^{-N})$ |
| 0000000001 | $-V_{REF} (2^{-N})$ |
| 0000000000 | 0 |

NOTES:

1. $LSB = 2^{-N} V_{REF}$
2. $N = 10$ for 7520, 7530
 $N = 12$ for 7521, 7531

Zero Offset Adjustment

1. Connect all digital inputs to GND.
2. Adjust the offset zero adjust trimpot of the output operational amplifier for 0V at V_{OUT} .

Gain Adjustment

1. Connect all digital inputs to $V+$.
2. Monitor V_{OUT} for a $-V_{REF} (1-2^{-N})$ reading. ($N = 10$ for AD7520/30 and $N = 12$ for AD7521/31).
3. To decrease V_{OUT} , connect a series resistor (0 to 250 Ω) between the reference voltage and the V_{REF} terminal.
4. To increase V_{OUT} , connect a series resistor (0 to 250 Ω) in the I_{OUT1} amplifier feedback loop.

Bipolar (Offset Binary) Operation

The circuit configuration for operating the AD7520 in the bipolar mode is given in Figure 9. Similar circuits can be used for AD7521, AD7530 and AD7531. Using offset binary digital input codes and positive and negative reference voltage values, 4-Quadrant multiplication can be realized. The

"Digital Input Code/Analog Output Value" table for bipolar mode is given in Table 2.

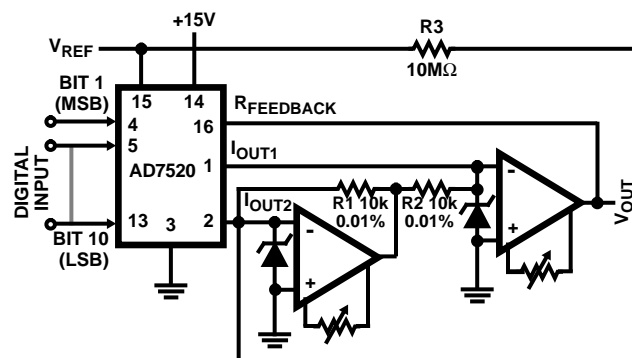

FIGURE 9. BIPOLAR OPERATION (4-QUADRANT MULTIPLICATION)

TABLE 2. BIPOLAR (OFFSET BINARY) CODE TABLE

| DIGITAL INPUT | ANALOG OUTPUT |
|---------------|---------------------------|
| 1111111111 | $-V_{REF} (1-2^{-(N-1)})$ |
| 1000000001 | $-V_{REF} (2^{-(N-1)})$ |
| 1000000000 | 0 |
| 0111111111 | $V_{REF} (2^{-(N-1)})$ |
| 0000000001 | $V_{REF} (1-2^{-(N-1)})$ |
| 0000000000 | V_{REF} |

NOTES:

1. $LSB = 2^{-(N-1)} V_{REF}$
2. $N = 10$ for 7520, 7521
 $N = 12$ for 7530, 7531

A "Logic 1" input at any digital input forces the corresponding ladder switch to steer the bit current to I_{OUT1} bus. A "Logic 0" input forces the bit current to I_{OUT2} bus. For any code the I_{OUT1} and I_{OUT2} bus currents are complements of one another. The current amplifier at I_{OUT2} changes the polarity of I_{OUT2} current and the transconductance amplifier at I_{OUT1} output sums the two currents. This configuration doubles the output range. The difference current resulting at zero offset binary code, (MSB = "Logic 1", All other bits = "Logic 0"), is corrected by using an external resistor, (10M Ω), from V_{REF} to I_{OUT2} .

Offset Adjustment

1. Adjust V_{REF} to approximately +10V.
2. Connect all digital inputs to "Logic 1".
3. Adjust I_{OUT2} amplifier offset adjust trimpot for 0V \pm 1mV at I_{OUT2} amplifier output.
4. Connect MSB (Bit 1) to "Logic 1" and all other bits to "Logic 0".
5. Adjust I_{OUT1} amplifier offset adjust trimpot for 0V \pm 1mV at V_{OUT} .

Gain Adjustment

1. Connect all digital inputs to $V+$.
2. Monitor V_{OUT} for a $-V_{REF} (1-2^{-(N-1)})$ volts reading. ($N = 10$ for AD7520 and AD7530, and $N = 12$ for AD7521 and AD7531).
3. To increase V_{OUT} , connect a series resistor of up to 250 Ω between V_{OUT} and $R_{FEEDBACK}$.
4. To decrease V_{OUT} , connect a series resistor of up to 250 Ω between the reference voltage and the V_{REF} terminal.

AD7520, AD7530

Die Characteristics

DIE DIMENSIONS:

101 x 103mils (2565 x 2616micrms)

METALLIZATION:

Type: Pure Aluminum
Thickness: $10 \pm 1\text{k}\text{\AA}$

GLASSIVATION:

Type: PSG/NITRIDE
PSG: $7 \pm 1.4\text{k}\text{\AA}$
NITRIDE: $8 \pm 1.2\text{k}\text{\AA}$

PROCESS: CMOS Metal Gate

Metallization Mask Layout

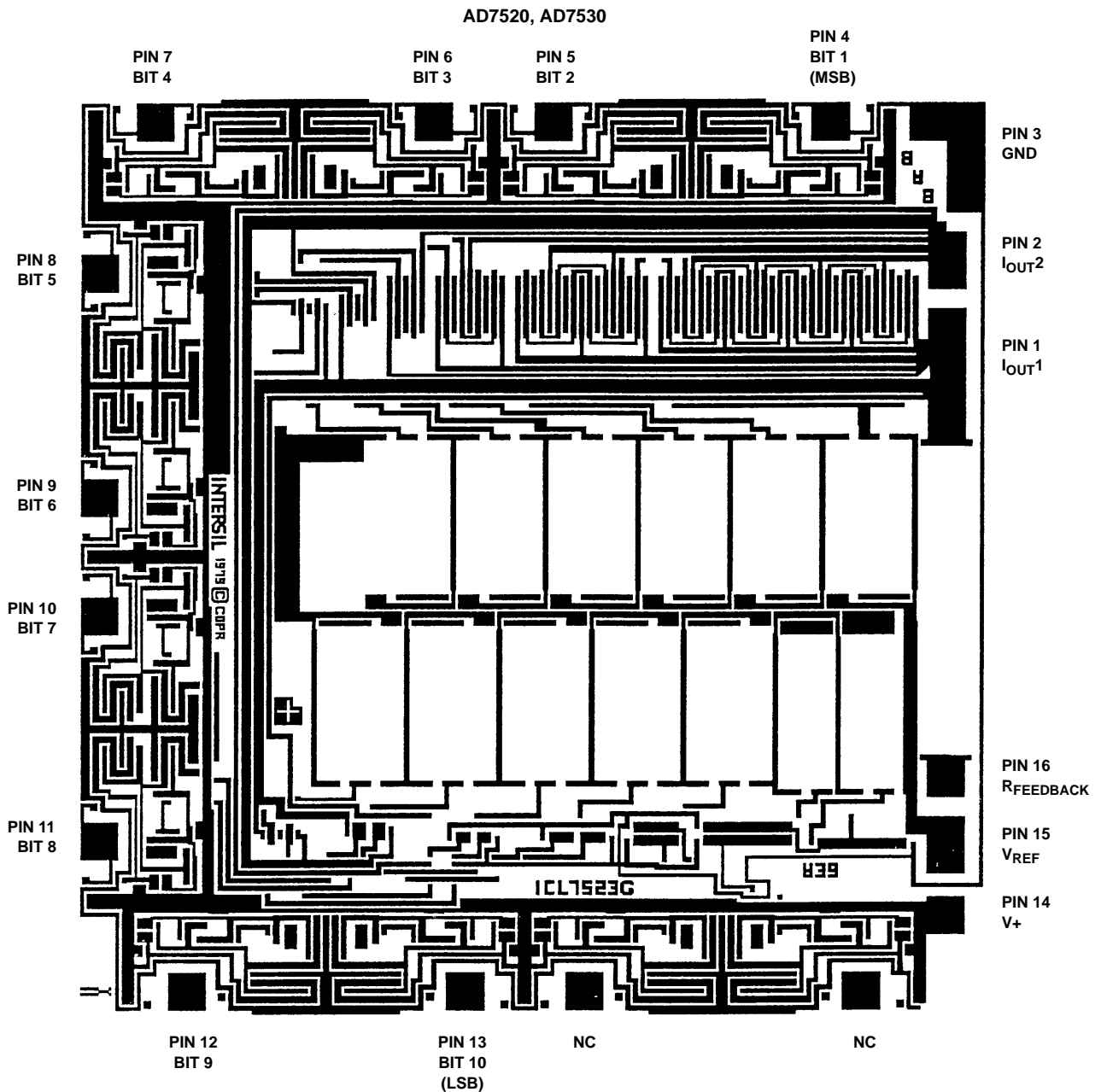

AD7521, AD7531

Die Characteristics

DIE DIMENSIONS:

101 x 103mils (2565 x 2616micrms)

METALLIZATION:

Type: Pure Aluminum
Thickness: $10 \pm 1\text{k}\text{\AA}$

GLASSIVATION:

Type: PSG/NITRIDE
PSG: $7 \pm 1.4\text{k}\text{\AA}$
NITRIDE: $8 \pm 1.2\text{k}\text{\AA}$

PROCESS: CMOS Metal Gate

Metallization Mask Layout

