

DI100/150 THRU DI1010/1510

DUAL-IN-LINE GLASS PASSIVATED SINGLE-PHASE BRIDGE RECTIFIER
VOLTAGE - 50 to 1000 Volts CURRENT - 1.0-1.5 Ampere

 **Recognized File #E111753**

FEATURES

- Plastic material used carries Underwriters Laboratory recognition 94V-O.
- Low leakage.
- Surge overload rating—30-50 amperes peak.
- Ideal for printed circuit board.
- Exceeds environmental standards of MIL-S-19500/228

MECHANICAL DATA

Case: Reliable low cost construction utilizing molded plastic technique results in inexpensive product.

Terminals: Lead solderable per MIL-STD-202, Method 208.

Polarity: Polarity symbols molded or marking on body.

Mounting position: Any.

Weight: 0.02 ounce, 0.4 gram.

DIP

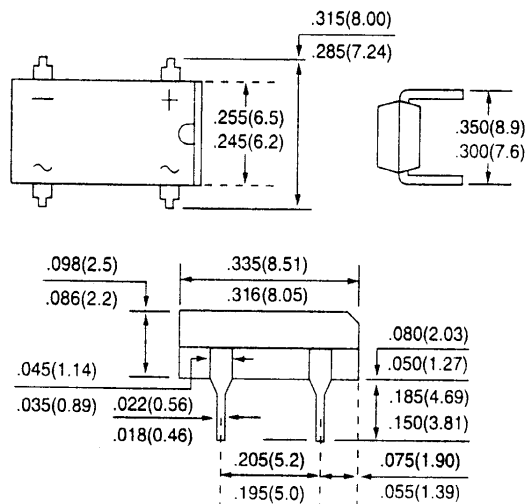

Dimensions in inches and (millimeters)

MAXIMUM RATINGS AND ELECTRICAL CHARACTERISTICS

Ratings at 25°C ambient temperature unless otherwise specified.

Single phase, half wave, 60 Hz, resistive or inductive load.

For capacitive load, derate current by 20%.

	DI100 DI150	DI101 DI151	DI102 DI152	DI104 DI154	DI106 DI156	DI108 DI158	DI1010 DI1510	UNITS
Maximum Recurrent Peak Reverse Voltage	50	100	200	400	600	800	1000	V
Maximum RMS Bridge Input Voltage	35	70	140	280	420	560	700	V
Maximum DC Blocking Voltage	50	100	200	400	600	800	1000	V
Maximum Average Forward Current T _A = 40°C	DI100 DI150			1.0 1.5				A
Peak Forward Surge Current, 8.3 ms single half sine-wave superimposed on rated load	DI100 DI150			30.0 50.0				A
I ² t Rating for fusing (t < 8.35 ms)				10.0				A ² t
Maximum Forward Voltage Drop per Bridge Element at 1.0 A				1.1				V
Maximum Reverse Current at Rated DC Blocking Voltage per element				5.0 0.5				μA mA
Typical junction capacitance per leg (NOTE 1) C _J				25.0				pF
Typical thermal resistance per leg (NOTE 2) R _{θJA}				40.0				°C/W
Typical thermal resistance per leg (NOTE 2) R _{θJL}				15.0				
Operating Temperature Range T _J				-55 to 125				°C
Storage Temperature Range T _A				-55 to 150				°C

NOTES:

1. Measured at 1.0MHZ and applied reverse voltage of 4.0 volts.
2. Thermal resistance from junction to ambient and from junction to lead mounted on P.C.B with 0.5 x 0.5" (13 x 13mm) copper pads.

RATING AND CHARACTERISTIC CURVES
DI100/150 THRU DI1010/1510

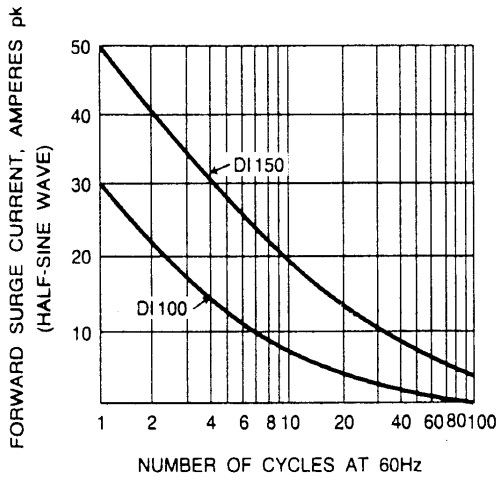

Fig. 1 - MAXIMUM NON-REPETITIVE SURGE CURRENT

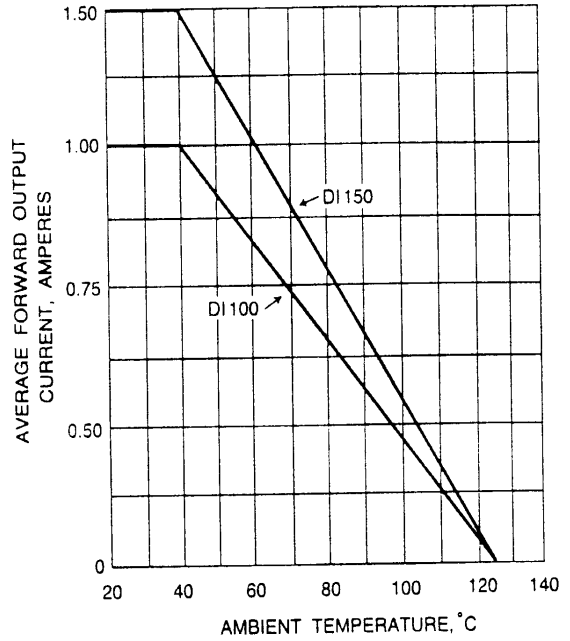

Fig. 2 - DERATING CURVE FOR OUTPUT RECTIFIED CURRENT

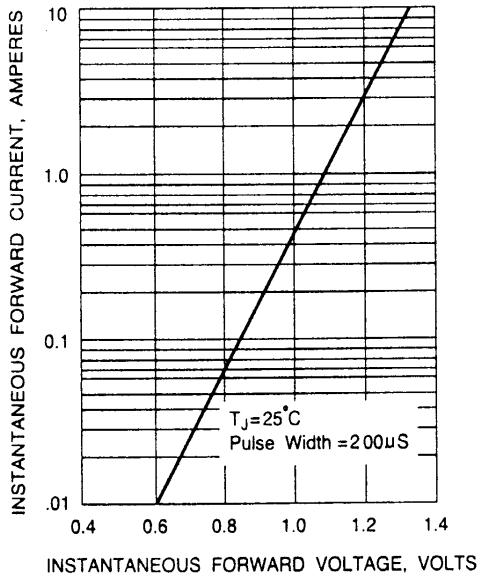

Fig. 3 - TYPICAL FORWARD CHARACTERISTICS

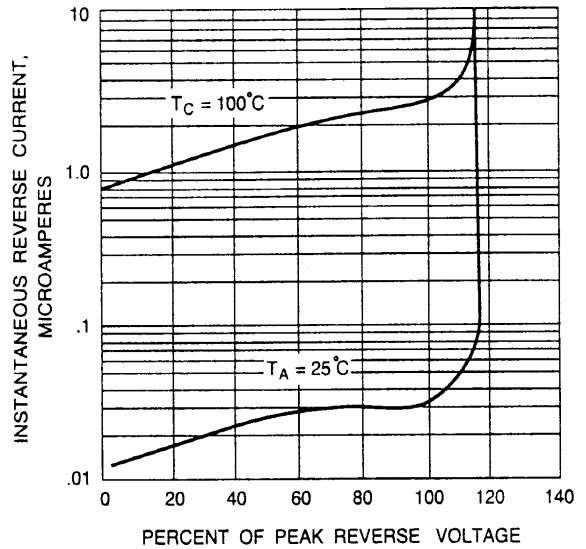

Fig. 4 - TYPICAL REVERSE CHARACTERISTICS