

Displacement measuring device



- Complete measuring system as kit or as single parts
- Holding device for encoder for perfect pressure
- With rack and pinion
- 1 turn around of the pinion is exact 50 mm easy to use

Description and application:

The holding device for the encoder (8.0010.7000.0004) is a movable support for encoders, to the shaft of which, for instance, a measuring wheel or pinion can be attached. Due to the fact that it is movable, optimum contact pressure is ensured and overload on the bearings of the encoder prevented. When used in conjunction with a pulse generating unit, the rack and pinion combination (8.0010.7000.0001 and ...0002)

serves as a simple length and displacement measuring system. One rotation of the pinion on the rack corresponds to a displacement of 50 mm. Moreover the racks are designed in such a way that they can be butt-mounted without pitch error. The absolute accuracy is 0.5 mm per meter. The resolution / repetition accuracy is 0.1 mm. Holding device, rack and pinion are available as a set for the purpose of displacement measurement (8.0010.7000.0005).

The installation aid (8.0010.7000.0003) is required to maintain exact pitch when buttmounting racks.

Typical areas of application are:

- Wood working industry
- Textile industry
- Handling and automation technology
- Mechanical engineering / Special machines

Holding device for encoders:

Material:
Guide rods: stainless steel
Bracket: Al

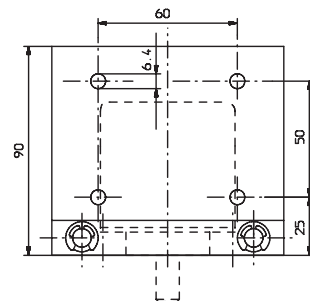
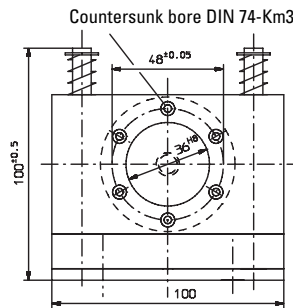
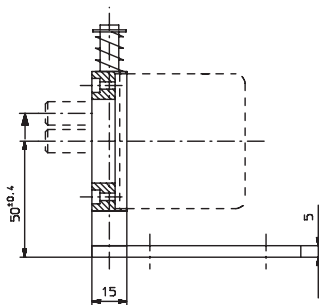

Ord.-No.
8.0010.7000.0004

Rack

Material: St 37
Surface: uncoated
Module pitch: approx. 1

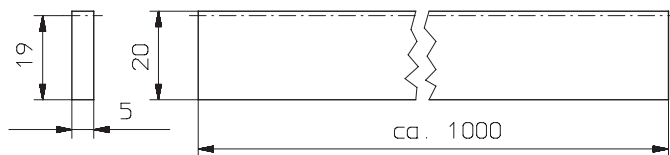

Ord.-No.
8.0010.7000.0001

Pinion

Material: free-cutting steel
Surface: burnished
Module pitch: approx. 1
No of teeth: 16

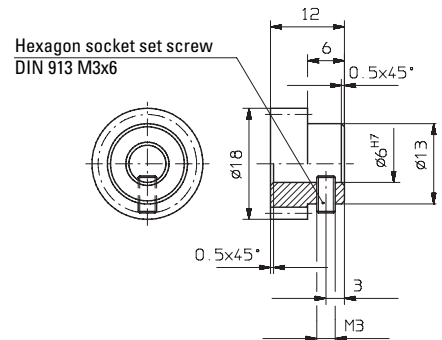

Ord.-No.
With bore diameter \varnothing 6 mm
8.0010.7000.0002
With bore diameter \varnothing 10 mm
8.0010.7000.0006

Installation aid

Material: St 37
Surface: uncoated
Module pitch: approx. 1

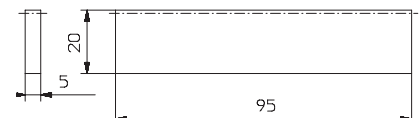

Ord.-No.
8.0010.7000.0003

Linear Measuring Technology

Length measuring kits

Length measuring kits

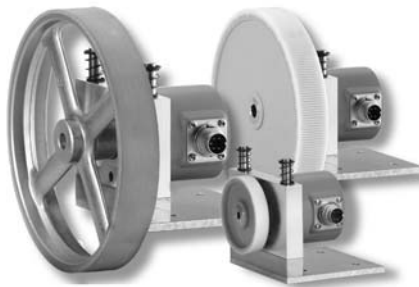

- Length measuring kit (metric) for length measurement of a measuring object that is moving; a complete solution, which can quickly and easily be implemented!
- Measuring wheels (Hytrel plastic for the textile industry, Vulkollan for the wood, paper, metal and plastics industries).
- Resolution of 1 mm for measuring wheels.
- Because of the encoder holding device, an optimal loading of the encoder shaft on the rack is achieved.
- An additional power supply for the encoder is not required, as the encoder can be powered directly from the preset counter.

Technical data:

Measuring wheels: Circumfer. 0.2 m:	Standard bore 6 mm, measuring width 12 mm, wheel body made of plastic, weight 35 g.
Circumfer. 0.5 m:	Standard bore 10 mm, measuring width 25 mm, wheel body made of plastic (Hytrel) or aluminum (Vulkollan). Weight 260 g (Hytrel), 320 g (Vulkollan).

Encoder holding device:

Bracket 100x100 mm Al,
Guide rod: stainless steel, Countersunk bore DIN74-Km3,

Encoders, cable assembly:

See detailed technical specifications in this catalogue.

Counter:

See catalogue Counting Technology

Ordering information:

6.716.010.000	716 LED preset counter 90-260VAC, 1 preset
8.0000.3291.0010	0.2 m measuring wheel, plastic (Hytrel) corrugated
8.0000.3552.0010	0.5 m measuring wheel, plastic (Vulkollan) smooth
8.0000.3592.0010	0.5 m measuring wheel, plastic (Hytrel) corrugated
8.0000.6201.0003	Cable assembly for measuring wheel-length measuring kit
8.0000.6311.0003	Cable assembly for rack and pinion-length measuring kit
8.0010.7000.0004	Flexible holding device for encoders
8.5802.1275.0200	5802 encoder for 0.2m measuring wheel, 1 mm resolution
8.5802.1275.0500	5802 encoder for 0.5m measuring wheel, 1 mm resolution
8.5810.1145.0500	5810 encoder for rack and pinion, 0.1 mm resolution