

ECL Series



- Ultra Compact Size
- Single Outputs from 3.3 to 48 V
- PCB Mount, Open Frame & Chassis Mount
- Encapsulated PCB & Chassis Mount
- Class II Construction
- Peak Load Capability
- 3 Year Warranty

Specification

Input

Input Voltage	• 85-264 VAC (120-370 VDC)
Input Frequency	• 47-63 Hz
Input Current	• ECL05: 0.1 A rms at 230 VAC ECL10: 0.2 A rms at 230 VAC ECL15: 0.3 A rms at 230 VAC ECL25: 0.4 A rms at 230 VAC
Inrush Current	• 20 A at 115 VAC, 40 A at 230 VAC,
Earth Leakage Current	• Class II construction no earth
Input Protection	• ECL05/10: Internal T1 A/250 VAC fuse ECL15/25: Internal T2 A/250 VAC fuse

Output

Output Voltage	• See tables
Output Voltage Trim	• $\pm 5\%$ (not '-E' or '-S' versions)
Initial Set Accuracy	• $\pm 1\%$
Minimum Load	• No minimum load required
Start Up Delay	• 2 s max
Start Up Rise Time	• 14 ms max
Hold Up Time	• 16 ms typical at full load & 115 VAC
Line Regulation	• $\pm 0.5\%$ max
Load Regulation	• $\pm 1\%$ max
Transient Response	• 4% max deviation, recovery to within 1% in 500 μ s for a 25% load change
Ripple & Noise	• 3.3-5 V versions: 50 mV pk-pk, 12-15 V versions: 120 mV pk-pk, 24-48 V versions: 200 mV pk-pk, 20 MHz bandwidth
Overvoltage Protection	• 115-135% Vnom, recycle input to reset
Overload Protection	• ECL05/10/15: 120-150% ECL25: 120-170%
Short Circuit Protection	• Trip and restart (Hiccup mode)
Temperature Coefficient	• 0.05%/ $^{\circ}$ C

General

Efficiency	• See tables
Isolation	• 3000 VAC Input to Output
Switching Frequency	• 70 kHz typical
Power Density	• ECL05: 2.25 W/In ³ (PCB Mount version) ECL10: 5.50 W/In ³ (PCB Mount version) ECL15: 4.80 W/In ³ (PCB Mount version) ECL25: 5.60 W/In ³ (PCB Mount version)
MTBF	• ECL05/10: >450 kHrs to MIL-HDBK-217F ECL15/25: >400 kHrs to MIL-HDBK-217F at 25 $^{\circ}$ C, GB

Environmental

Operating Temperature	• -20 $^{\circ}$ C to +70 $^{\circ}$ C, derate linearly from 100% at +50 $^{\circ}$ C to 50% at +70 $^{\circ}$ C
Cooling	• Convection-cooled
Operating Humidity	• 95% RH, non-condensing
Storage Temperature	• -40 $^{\circ}$ C to +85 $^{\circ}$ C
Operating Altitude	• 3000 m
Vibration	• 2 g, 10 Hz to 500 kHz, 10 mins/cycle, 60 mins each cycle

EMC & Safety

Emissions	• EN55022, level B conducted & radiated
Harmonic Currents	• EN61000-3-2, EN61000-3-3
ESD Immunity	• EN61000-4-2, level 3 Perf Criteria A
Radiated Immunity	• EN61000-4-3, 10 V/m 80% mod Perf Criteria A
EFT/Burst	• EN61000-4-4, level 3 Perf Criteria A
Surge	• EN61000-4-5, level 3 Perf Criteria A
Conducted Immunity	• EN61000-4-6, 10 Vrms Perf Criteria A
Magnetic Fields	• EN61000-4-8, 10 A/m Perf Criteria A
Dips & Interruptions	• EN61000-4-11, 30% for 10 ms, 60% for 100 ms, 100% for 5000 ms Perf Criteria A, B, B
Safety Approvals	• EN60950, UL60950, CSA22.2 No. 234 per cUL

Models and Ratings

Output Power	Output Voltage	Output Current		Efficiency	Model Number ⁽²⁾
		Nominal	Peak ⁽¹⁾		
4.3 W	3.3 VDC	1.30 A	1.69 A	72%	ECL05US03
5.0 W	5.0 VDC	1.00 A	1.30 A	75%	ECL05US05
5.0 W	9.0 VDC	0.55 A	0.71 A	78%	ECL05US09
5.0 W	12.0 VDC	0.41 A	0.54 A	78%	ECL05US12
5.0 W	15.0 VDC	0.33 A	0.44 A	80%	ECL05US15
5.0 W	24.0 VDC	0.21 A	0.27 A	82%	ECL05US24
5.0 W	48.0 VDC	0.10 A	0.13 A	82%	ECL05US48
8.6 W	3.3 VDC	2.60 A	3.38 A	72%	ECL10US03 [†]
10.0 W	5.0 VDC	2.00 A	2.60 A	75%	ECL10US05 [†]
10.0 W	9.0 VDC	1.10 A	1.43 A	78%	ECL10US09 [†]
10.0 W	12.0 VDC	0.83 A	1.08 A	78%	ECL10US12 [†]
10.0 W	15.0 VDC	0.67 A	0.87 A	80%	ECL10US15 [†]
10.0 W	24.0 VDC	0.42 A	0.55 A	82%	ECL10US24 [†]
10.0 W	48.0 VDC	0.21 A	0.27 A	82%	ECL10US48 [†]

Notes

1. Peak load lasting <30 s with a maximum duty cycle of 10%, average output power not to exceed nominal.
2. Add suffix to model number to define type: add '-P' for PCB mount, add '-T' for chassis mount, add '-E' for encapsulated.

[†] Available from Farnell. See pages 266-269.

[^] Available from Newark. See pages 270-272.

Mechanical Details

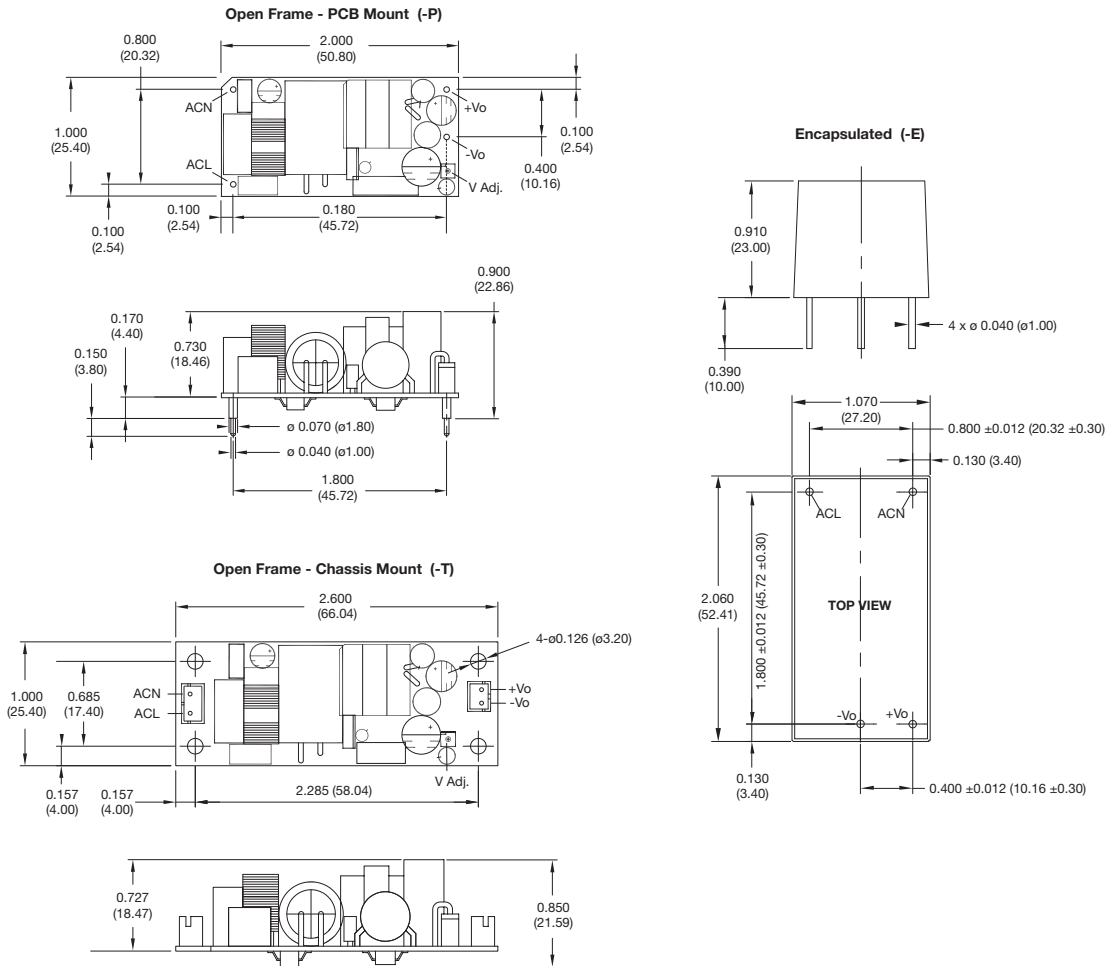

Notes

1. Dimensions in inches (mm).
2. Weight: ECL05/10 (P Version): 0.057 lbs (26 g)
ECL05/10 (T Version): 0.057 lbs (26 g)
ECL05/10 (E Version): 0.13 lbs (60 g)
3. Tolerances: x.xx = ± 0.02 (x.x = ± 0.5)
x.xxx = ± 0.01 (x.xx = ± 0.25)

Mating Connectors (Chassis mount only)

Input Connector: JST PHR-3
Output Connector: JST PHR-2
Crimps: SPH-002T-P0.5S
Cable harness with 300 mm wire available, order part no. ECL10 LOOM KIT



Output Power	Output Voltage	Output Current		Efficiency	Model Number ⁽²⁾
		Nominal	Peak ⁽¹⁾		
10 W	3.3 VDC	3.00 A	3.90 A	75%	ECL15US03†^
15 W	5.0 VDC	3.00 A	3.90 A	78%	ECL15US05†^
15 W	9.0 VDC	1.67 A	2.17 A	80%	ECL15US09†^
15 W	12.0 VDC	1.25 A	1.62 A	80%	ECL15US12†^
15 W	15.0 VDC	1.00 A	1.30 A	80%	ECL15US15†^
15 W	24.0 VDC	0.63 A	0.82 A	82%	ECL15US24†^
15 W	48.0 VDC	0.32 A	0.41 A	82%	ECL15US48†^

Notes

1. Peak load lasting <30 s with a maximum duty cycle of 10%, average output power not to exceed nominal.
2. Add suffix to model number to define type: add '-P' for PCB mount, add '-T' for chassis mount, add '-E' for encapsulated, add '-S' for screw terminals.
3. For medically-approved 15 W power supplies contact sales or see www.xppower.com for details of CU15-M Series.

† Available from Farnell. See pages 266-269.

^ Available from Newark. See pages 270-272.

Mechanical Details

Open Frame - PCB Mount (-P)

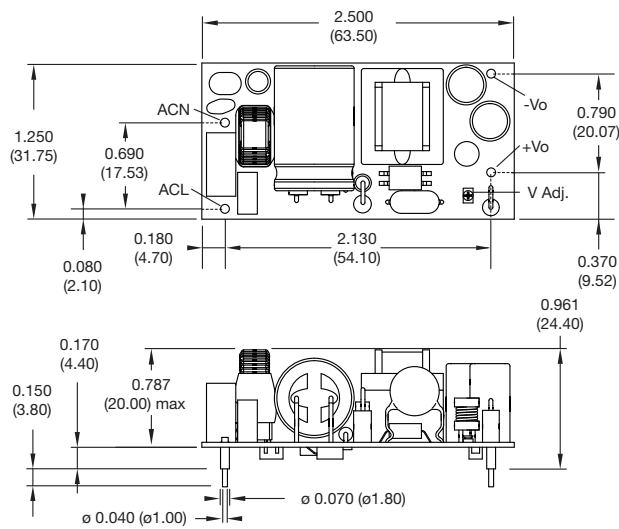

Encapsulated (-E)

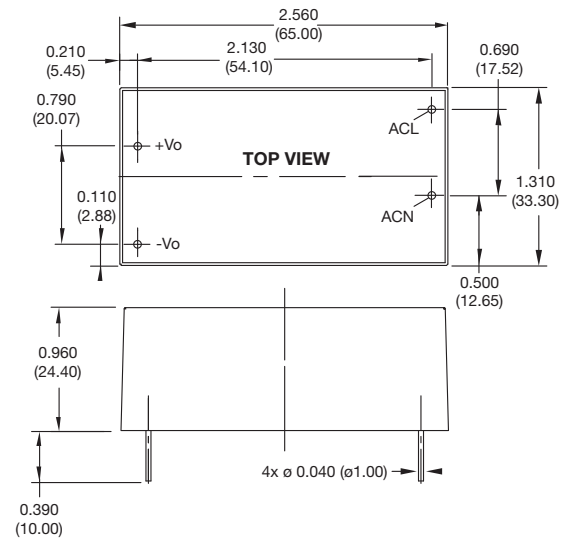

Open Frame - Chassis Mount (-T)

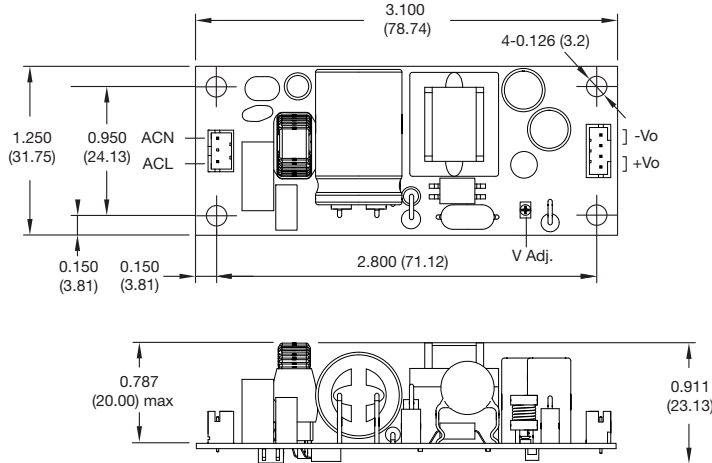

Screw Terminal (-S)

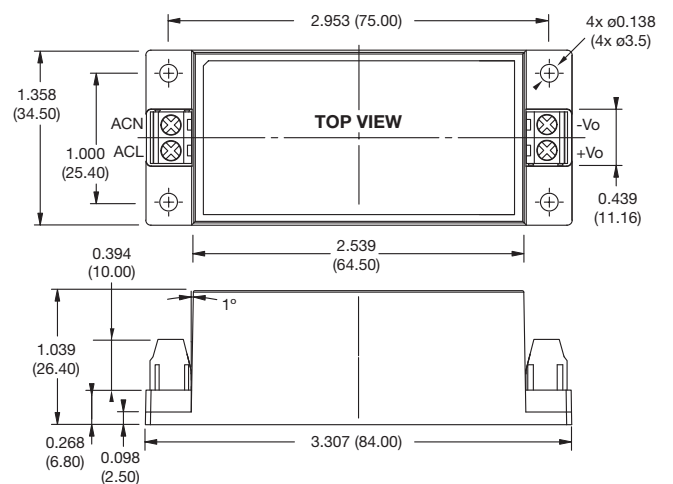

Notes

1. Dimensions in inches (mm).
2. ECL15 (P Version): 0.07 lbs (35 g)
ECL15 (T Version): 0.07 lbs (35 g)
ECL15 (E Version): 0.20 lbs (90 g)
ECL15 (S Version): 0.24 lbs (110 g)
3. Tolerances: x.xx = ± 0.02 (x.x = ± 0.5)
x.xxx = ± 0.01 (x.xx = ± 0.25)

Mating Connectors (-T version only)

Input Connector: JST PHR-3
Output Connector: JST PHR-4
Crimps: SPH-002T-P0.5S
Cable harness with 300 mm wire available, order part no. ECL15 LOOM KIT

Output Power	Output Voltage	Output Current		Efficiency	Model Number ⁽²⁾
		Nominal	Peak ⁽¹⁾		
20 W	3.3 VDC	6.00 A	7.80 A	75%	ECL25US03†^
25 W	5.0 VDC	5.00 A	6.50 A	78%	ECL25US05†^
25 W	9.0 VDC	2.80 A	3.64 A	80%	ECL25US09†^
25 W	12.0 VDC	2.10 A	2.73 A	80%	ECL25US12†^
25 W	15.0 VDC	1.67 A	2.17 A	80%	ECL25US15†^
25 W	24.0 VDC	1.04 A	1.35 A	82%	ECL25US24†^
25 W	48.0 VDC	0.52 A	0.68 A	82%	ECL25US48†^

Notes

- Peak load lasting <30 s with a maximum duty cycle of 10%, average output power not to exceed nominal.
- Add suffix to model number to define type: add '-P' for PCB mount, add '-T' for chassis mount, add '-E' for encapsulated, add '-S' for screw terminals.

† Available from Farnell. See pages 266-269.

^ Available from Newark. See pages 270-272.

Mechanical Details

Open Frame - PCB Mount (-P)

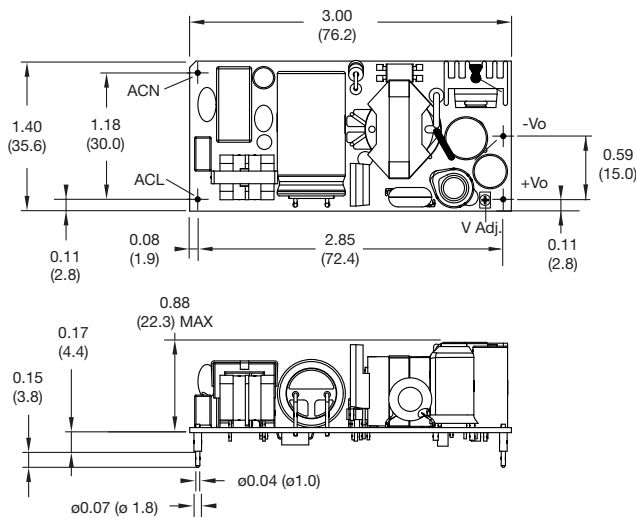

Encapsulated (-E)

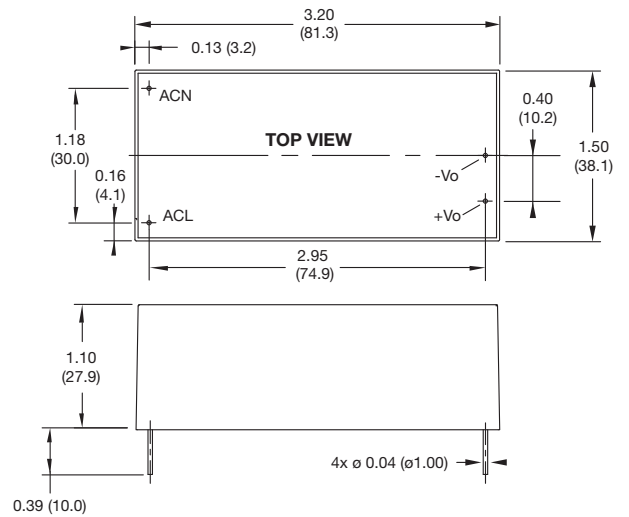

Open Frame - Chassis Mount (-T)

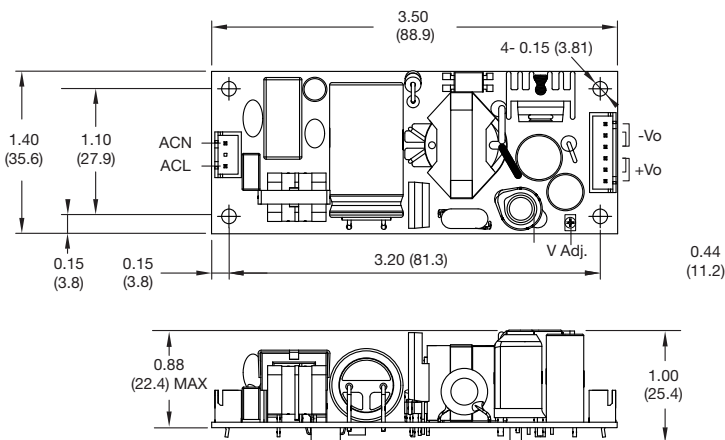

Screw Terminal (-S)

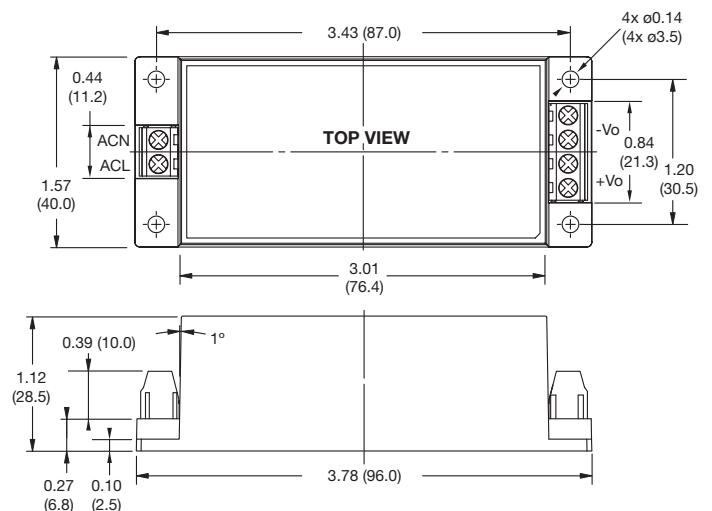

Notes

- Dimensions in inches (mm).
- Tolerances: x.xx = ± 0.02 (x.x = ± 0.5)
x.xxx = ± 0.01 (x.xx = ± 0.25)
- Weight: ECL25 (P Version): 0.14 lbs (66 g)
ECL25 (T Version): 0.14 lbs (66 g)
ECL25 (E Version): 0.33 lbs (150 g)
ECL25 (S Version): 0.37 lbs (170 g)

Mating Connectors (-T version only)

- Input Connector: JST XHP-3
- Output Connector: JST XHP-6
- Crimps: SXH-002T-P0.6
- Cable harness with 300 mm wire available, order part no. ECL25 LOOM KIT