

LOC	DIST	REVISIONS			
P	LTR	DESCRIPTION	DATE	DWN	APVD
E	B	A	RELEASE FOR PRODUCTION	18.12.00	RS RG

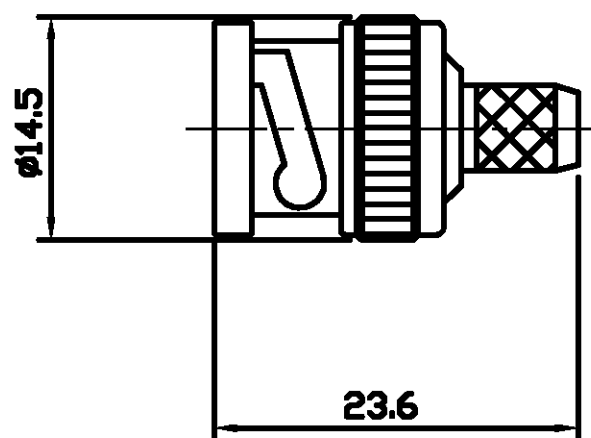

△ SUPPLIED SEMI-ASSEMBLED (PACK CONTAINS LOOSE PIECES)
 VIEW SHOWS ASSEMBLED CONNECTOR (CABLE OMITTED)
 FOR CABLE TO CONNECTOR ASSEMBLY GUIDANCE
 REFER TO TYCO INSTRUCTION SHEET I.S 411 - 3247

ALL DIMENSIONS ARE NOMINAL. FOR REFERENCE ONLY.

DIE SET PART NUMBER	9-1478242-0
HANDTOOL PART NUMBER	9-1478240-0
FOR USE ON CABLES	URM70
CONNECTOR PLATING DETAIL	SILVER
CONTACT PLATING DETAIL	SILVER
DIELECTRIC MATERIAL	TEFLON
GASKET MATERIAL	WHITE SILICONE RUBBER

BAG	SINGLE ITEM	1-1478103-0
PACK TYPE	DESCRIPTION	PART NUMBER

THIS DRAWING IS A CONTROLLED DOCUMENT.		DWN	R SMITH	18.12.00	Tyco Electronics Corporation Stanmore, Middlesex, HA7 4RS	
DIMENSIONS: MM		CHK	R GOODALL	18.12.00	NAME BNC STRT PLUG CRIMP URM70 75 OHM	
TOLERANCES UNLESS OTHERWISE SPECIFIED:		APVD	R GOODALL	18.12.00	PRODUCT SPEC 108-3435	
0 PLC ± -		APPLICATION SPEC		SIZE		CAGE CODE
1 PLC ± -		WEIGHT		DRAWING NO		RESTRICTED TO
2 PLC ± -		CUSTOMER DRAWING		A3 00779		©-1478103
3 PLC ± -		SCALE		SHEET		REV
4 PLC ± -		NTS		1 OF 1		A
ANGLES ± -						
MATERIAL	FINISH					
-	-					