

- ① HOUSING MATERIAL: GLASS-FILLED POLYMER.
- ② POST MATERIAL: COPPER ALLOY.
- ③ POST FINISH: DIN 41612 CLASS 2 IN CONTACT AREA. TIN PLATE ON POSTS.
- ④ MARKING ON THIS SIDE.
- ⑤ RECOMMENDED HOLE SIZE FOR MANUAL APPLICATION OF CONNECTOR ONTO PC BOARD.
- ⑥ PART NUMBER, DATE CODE MARKED THIS APPROXIMATE AREA.

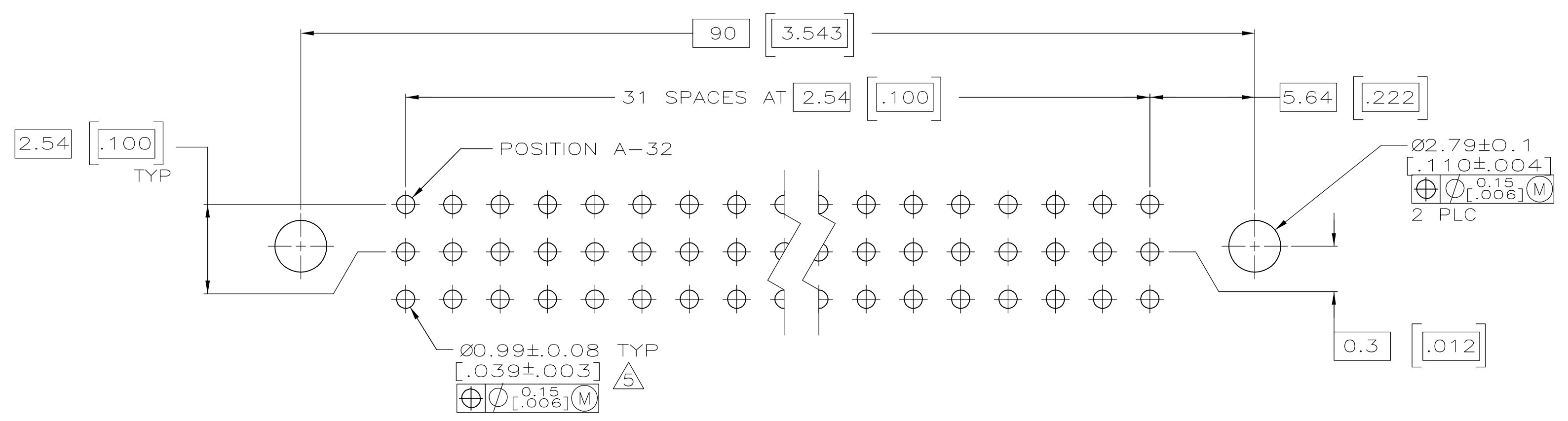
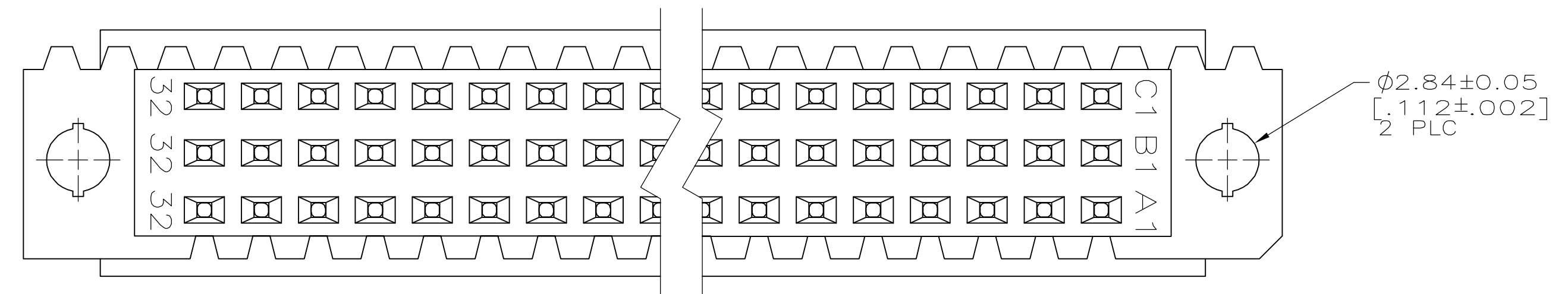
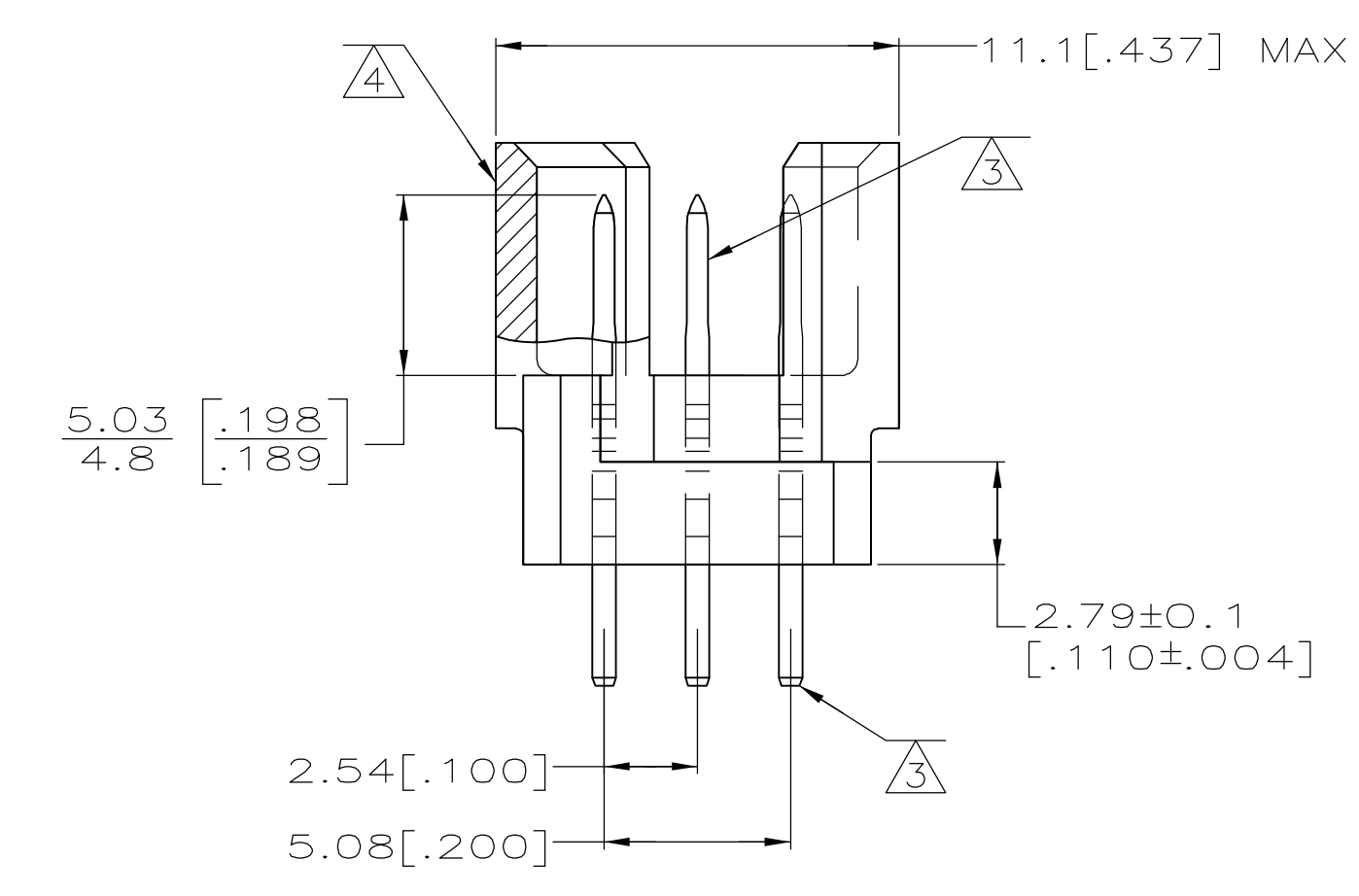
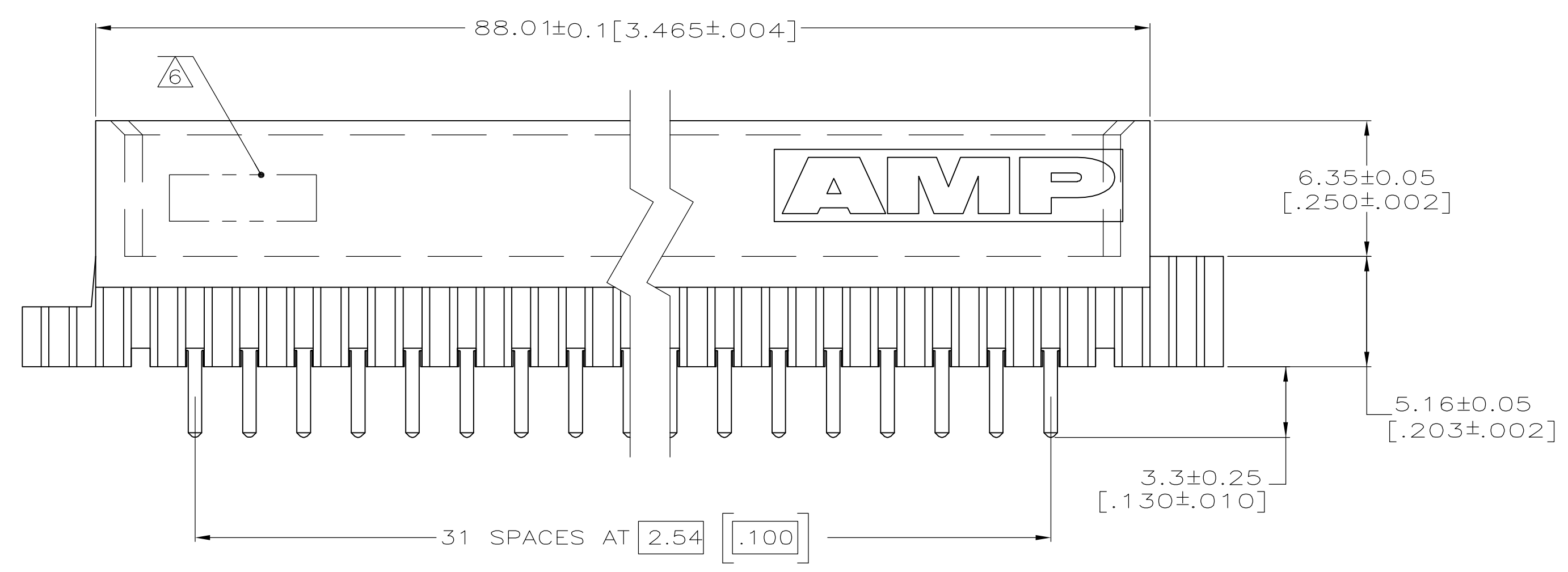
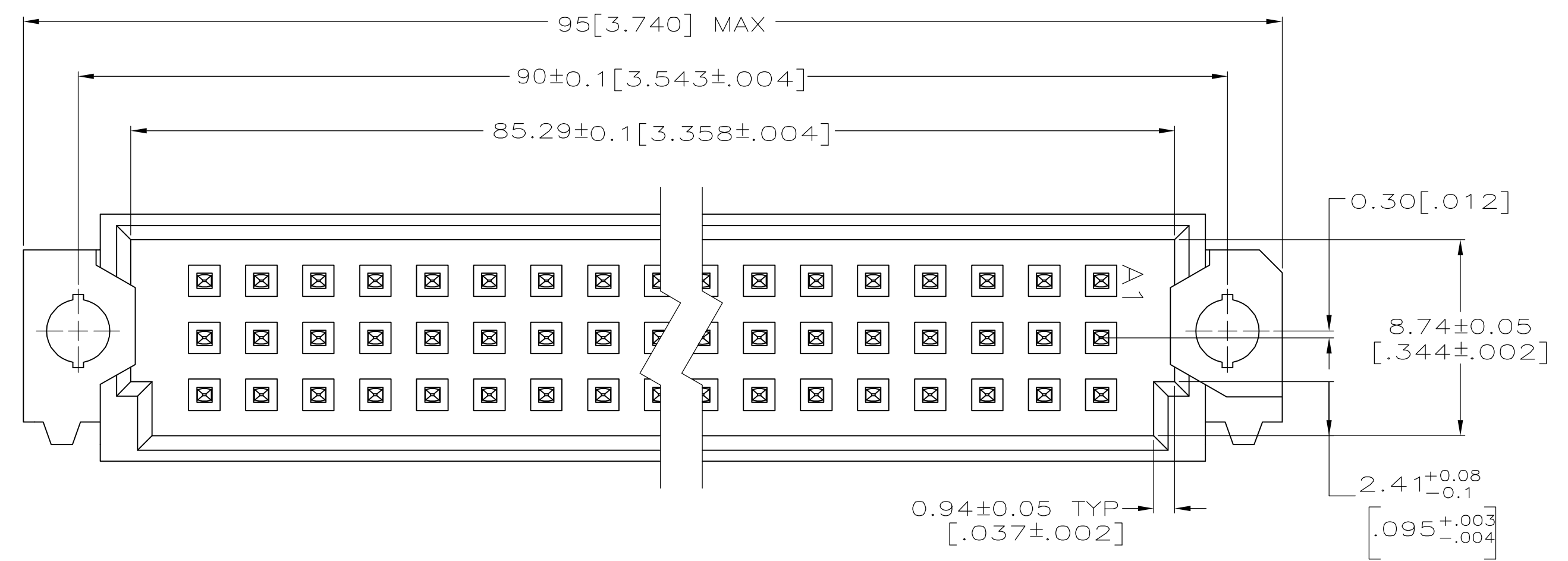

1-32	X	X	X	96	5650908-5
POSITIONS LOADED	C	B	A	NO. OF LOADED POSITION	ASSY PART NUMBER
	ROWS LOADED				

THIS DRAWING IS A CONTROLLED DOCUMENT.

DIMENSIONS: mm [INCHES]	TOLERANCES UNLESS OTHERWISE SPECIFIED:	DWN J. POLIGNONE	OSMAYOS	tyco Electronics	Tyco Electronics Corporation Harrisburg, Pa 17105-3608
0 PLC ± -	1 PLC ± -	CHK A. SHARPE	OSMAYOS	NAME	ASSEMBLY, PIN, EUROCARD, TYPE R, LEAD-FREE
2 PLC ± -	3 PLC ± 0.15[.005]	APPD A. SHARPE	OSMAYOS	PRODUCT SPEC	96 POSITION, 3.30[.130] SOLDER POST
4 PLC ± -	ANGLES ± -	APPLICATION SPEC		SIZE	A1
MATERIAL	FINISH	WEIGHT		CAGE CODE	00779
				DRAWING NO	5650908
				RESTRICTED TO	
				CUSTOMER DRAWING	SCALE 5:1 SHEET 1 OF 1 REV 0