

FEATURES

- COMPLETE ENCODER/TRANSMITTER MODULE.
- 1 - 4 SWITCH TRANSMITTER HOUSING.
- "CODE HOPPING" PROTOCOL FOR HIGH SECURITY.
- LOW POWER CONSUMPTION (>1 MILLION TRANSMISSIONS FROM A PP3 BATTERY).
- SUPPLIED AS COMPLETE ENCLOSURE, OR PCB MODULE WITH INTEGRAL ANTENNA.
- SUPPLIED WITH 9V PP3 BATTERY.
- DIRECTLY COMPATIBLE WITH R.F. SOLUTIONS FM DECODER UNITS.
- 418MHz 0.25mW ERP
- 433MHz 10mW ERP

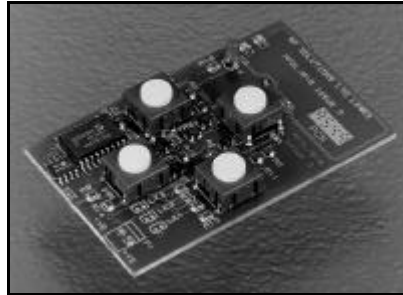

DESCRIPTION

The FM-EH4-XXX Transmitter/Encoder can be used to transmit R.F. Data to the RF Solutions range of FM Decoders. (see RF Solutions FM Decoder FM-DH4-XXX, or FM-DH1-XXX data sheet). As a system it enables the user to "bolt on" a remote control system to an application with a simple interface and minimal configuration set-up. When paired with one of the Receiver/Decoder Boards, a complete high security "code hopping" remote control system is achieved, with comprehensive interfacing capabilities.

Benefits of FM transmission include high reliability, long range, and low power, thus lending itself to many applications that cannot be implemented with an AM system. (A range of up to 200m in direct line of sight may be achieved).

It is supplied as either a pcb module or as a complete enclosed, hand held, remote control. As a complete remote control, the case may be supplied as a 1,2 or 4 switch transmitter. The case also has an integral battery compartment for a PP3 battery.

Up to eight Transmitter/Encoders can be taught to any one Decoder board. Additional Transmitter/Encoders and outputs may be added to the system using Expander Boards (see R.F Solutions FM Expander FM-EXP-1 data sheet for more details).

Custom solutions may also be supplied unique to customer specific requirements. Please contact R.F. Solutions for further information.

BLOCK DIAGRAM

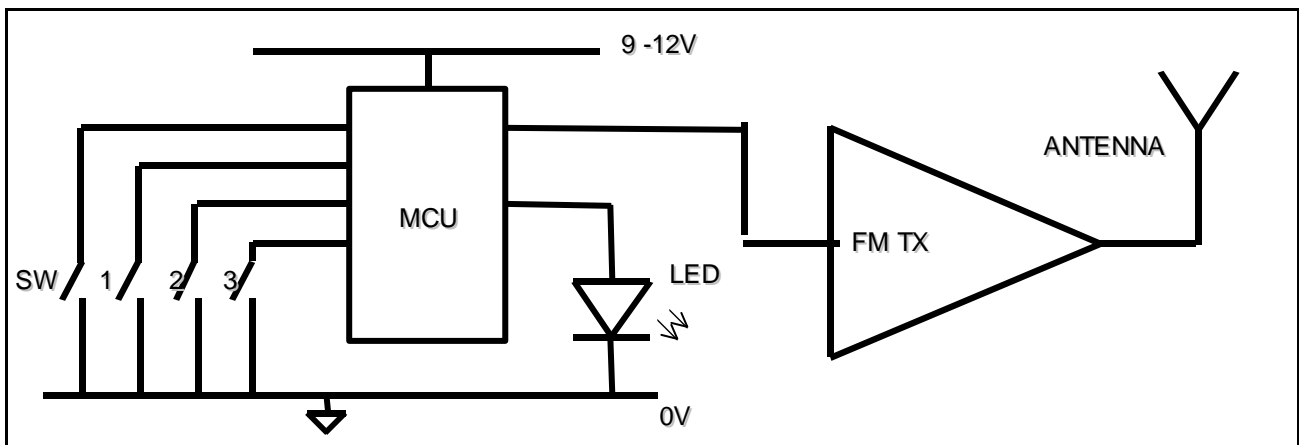

OPERATION

The transmitter transmits the code for as long as any push-button switch is depressed. Operation of the transmitter buttons will cause either a momentary action or a latching action at the decoder, depending on the configuration of the decoder or expander board

MECHANICAL DETAILS

When supplied as a complete remote control, in a plastic enclosure, one, two or four switch options are available. The overall dimensions of the case are

Length : 110mm, Width : 65mm, Depth :24mm

When supplied as a PCB level product the following mechanical details apply,

Length : 66mm, Width : 55mm

Note: reverse polarity connection will cause damage to the circuit.

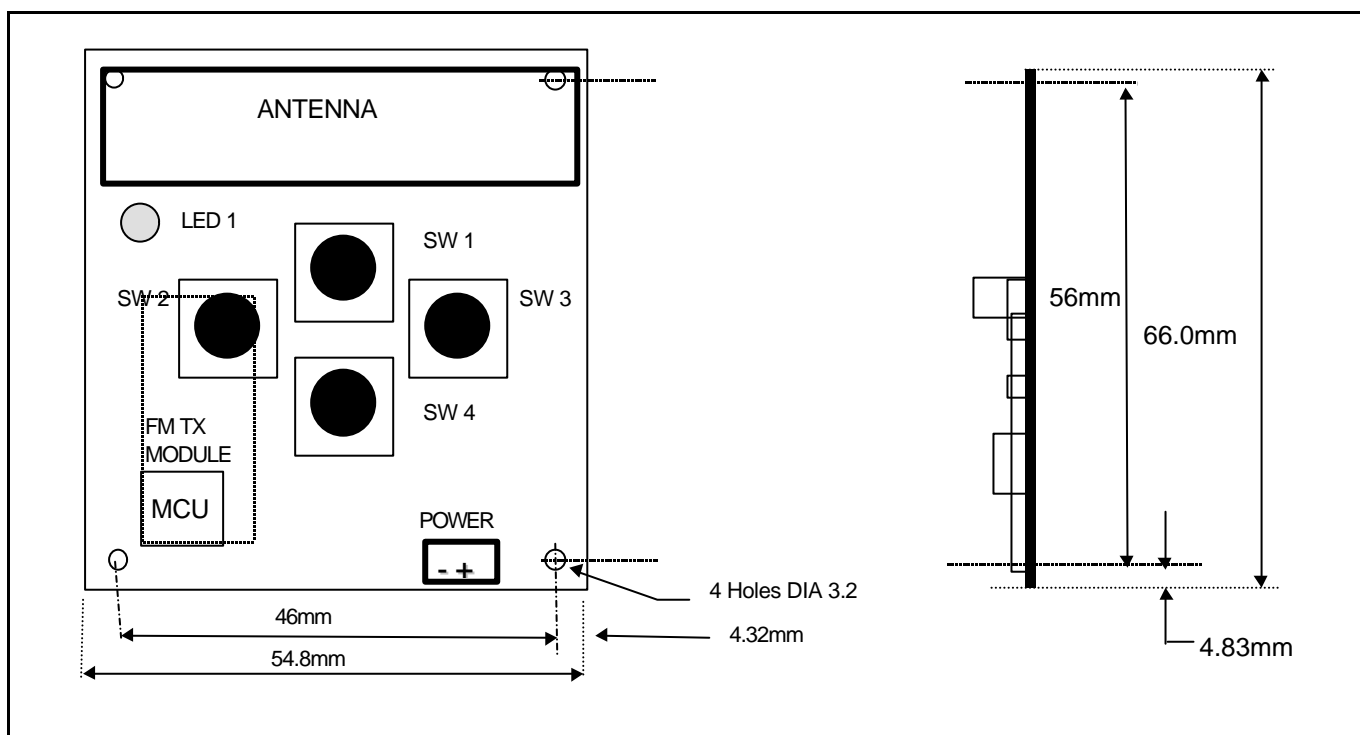

ANTENNA

The antenna has been included in the pcb tracking. This should provide adequate range for most applications. The range achieved from the system is dependent on the position of the antenna. If a custom antenna is required, for optimum range, follow these general rules;

- The space around the antenna is as important as the antenna itself.
- The optimum position is to locate the antenna so that it protrudes directly out the top of the transmitter box.
- If this is not possible due to other design constraints, try to keep the antenna away from other metal in the system such as transformers, batteries and PCB tracks, especially ground planes.
- In particular, the 'HOT' end of the antenna should be kept as far away as possible from these.

LICENCE EXEMPTION

This range of Radio transmitters is approved by the Department of Trade & Industry (D.T.I. Specification MPT1340) in the U.K., and therefore the user requires no radio operating licence in the U.K.

Please note however the following requirements to comply with MPT1340;

1. All transmitters shall use integral antennas only. Receivers may use an external or integral antenna. An integral antenna is defined as one which is designed to be connected permanently to the transmitter or receiver without the use of an external feeder.
2. The equipment in which the module is used must carry an inspection mark located on the outside of the equipment which is clearly visible. It shall state "MPT1340 W.T. Exempt". The minimum dimensions of the mark shall be 10 x 15mm and the figure height shall be not less than 2mm.

ABSOLUTE MAXIMUM RATINGS

Supply Voltage (Vcc to GND).....-0.3 to +13 Volts.
 Storage Temperature.....-10 to +70° Celcius.
 Operating Temperature.....0 to +55° Celcius.

TECHNICAL SPECIFICATION

Ambient temperature = 20° Celcius. Supply Voltage Vcc = 9 Volts.

ELECTRICAL CHARACTERISTICS	MIN	TYPICAL	MAX	DIMENSION	NOTE
Supply Voltage	8.5	9	12	V	
Supply Current					
Quiescent		0		mA	
Active		18		mA	
Operating Frequency	-	418.0	-	MHz	
RF Output Power (ERP)	-		0.25	mW	418MHz version
RF Output Power (ERP)	-		10	mW	433MHz version
Overall Frequency Accuracy	-100	0	+100	KHz	

ORDERING INFORMATION FM TRANSMITTERS

PART No	DESCRIPTION
FM-EH4 - XXX	Transmitter/Encoder, 4 Channel. PCB Only.
FM-EH1C - XXX	Transmitter/Encoder, 1 Channel. Supplied in Enclosure
FM-EH2C - XXX	Transmitter/Encoder, 2 Channel. Supplied in Enclosure
FM-EH4C - XXX	Transmitter/Encoder, 4 Channel. Supplied in Enclosure
XXX = FREQUENCY; 418MHz OR 433MHz.	

Should you require further assistance, please call;

**R. F. Solutions Ltd.,
 Unit 21, Cliffe Industrial Estate,
 South Street,
 Lewes,
 E Sussex, BN8 6JL. England.**

Tel +44 (0)1273 898 000. Fax +44 (0)1273 480 661.

Email : sales@rfsolutions.co.uk <http://www.rfsolutions.co.uk>

RF Solutions is a member of the Low Power Radio Association.



Information contained in this document is believed to be accurate, however no representation or warranty is given and no liability is assumed by R.F. Solutions Ltd. with respect to the accuracy of such information. Use of R.F.Solutions as critical components in life support systems is not authorised except with express written approval from R.F.Solutions Ltd.