

CUSTOMER Y02

Approval Sheet



DESIGNED NO.: SWITCHING POWER SUPPLIES

MODEL NO.: 3A-181WP18

ENG NO.: @3A-181WP18-027

APPROVAL		

Remark: 1).Please approve and sign back to ENG ELEC.
 2).If there is no signing back,this Approval sheet will be regarded as being approved automaticly once the first P.O. of the model specified in the sheet is issued.

SUPPLIER		
DESIGN	CHECKED	APPROVED
		



英格爾

英格爾科技股份有限公司
 ENG ELECTRIC CO., LTD.

台灣省桃園縣龜山鄉民生北路1段536號5樓
 5F,NO.536,Sec.1.Min Sheng N.Rd;Kweishan Hsiang,Taoyuan Hsien,Taiwan,R.O.C.
 TEL: 886-3-2121133, 886-3-212199
 FAX: 886-3-2121561

深圳英格爾電子有限公司
 SHENZHEN ENG ELECTRONICS CO., LTD.

深圳市寶安區福永鎮白石廈中核集團B棟
 Block B, Nuclear Group Industrial District, Baishixia, Fuyong Town, Bao'an, Shen Zhen China
 TEL: 86-755-27307512,27307515,27308750,27308755,27307208,27308202
 FAX: 86-755-27308049

SHENZHEN ENG ELECTRONICS CO., LTD.

FILE NO.: EN-RDS-6227

FILE: @3A-181WP18-027

產品承認書

SHEET: 01

1 Product Characteristics:

1.1 General Description

Model 3A-181WP18 is a universal switching-mode power supply, operating at input voltage 90VAC to 255VAC and output voltage of 18VDC with 1A DC load

1.2 Electric Characteristics

1.2.1 Input

No	ITEM	SPECIFICATION
1.	Rated input Voltage	AC100V-240V
	Vibration input Voltage Range	AC90V-255V
2.	Frequency Rated	50-60Hz
	Frequency Vibration	47-63Hz
3.	Input Rated Current	600mA RMS Max
	Inrush Current	30A Max .at 115vac cool start
		60A Max. at 230vac cool start
4.	Leakage current	0.25mA

SHENZHEN ENG ELECTRONICS CO., LTD.

FILE NO.: EN-RDS-6227

FILE: @3A-181WP18-027

產品承認書

SHEET: 02

1.2.2 Output:

No	ITEM	V1
1.	output Voltage	18VDC
2.	output max. current	1A
3.	output min. Current	0A
4.	Line regulation	$\pm 1\%$
5.	Load regulation	$\pm 5\%$
6.	Over voltage protection	19V to 21V DC(output shut down)
7.	Short circuit protection	Output shut down and auto restart
8.	Ripple Voltage (L.F.)	180mv (p-p) (100V-240VAC Input)

1.2.3 HI-POT SPECIFICATION

Input to output : 3000VAC or 4242VDC 10mA 1 minute.

1.2.4 Insulation resistance:

Input to output: 500vdc to test the input to output resistance not be less 100M ohm

1.2.5 Safety approval UL,CUL;TUV,CE;

1.3 Mechanical Characteristics

1.3.1 AC Plug : Interchangeable PII BS,UL,VDE,SAA,)

1.3.2 DC cord:

(1) Bending test: Life 1000 times 100% guarantee. Swings 120 from

Left to right loading weight 500g , 40 cycle/minute.

(2) Pull test : DC cord and plug ,weight 6kg for 1 minute.

1.3.3 Cord length and output plug: See Reference Att.4

1.3.4 Weight : _____ g

1.3.5 Case Size: (L)74 X (W) 43.5X (H) 34mm

1.3.6 Normal operating temperature and humidity

1.3.7 Temperature

Operating: 0°C to 40°C

Storage : -10°C to 70°C

1.3.8 Humidity

Operating : 20% to 80%.

Storage: 10% to 90%

SHENZHEN ENG ELECTRONICS CO., LTD.

FILE NO.: EN-RDS-6227

FILE: @3A-181WP18-027

產品承認書 SHEET: 04

2.Attachment:

- (Att.1) Label
- (Att.2) Outdrawing
- (Att.3) Package
- (Att.3.1) Package flow chart
- (Att.4) Dc cord drawing
- (Att.5) Material list
- (Att.6) Electrical test report

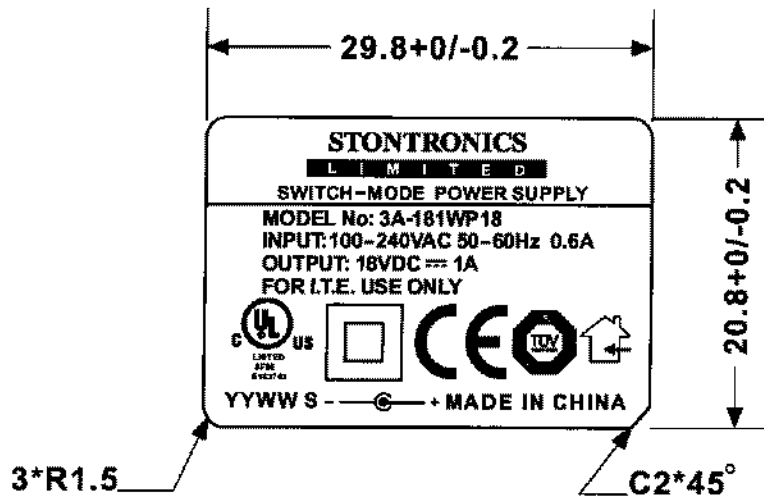

UNIT: mm

YYWW S YY:YEAR WW:WEEK S:FU YONG

ALUMINUM NAMEPLATE: ○ BLACK WORD ON SILVER BASE

○ SILVER WORD ON BLACK BASE

METALIZED POLYESTER: ● BLACK WORD ON SILVER BASE

(SILVER MATTE)

○ SILVER WORD ON BLACK BASE

@3A-181WP18-027

TOLERANCE				

DESIGNED	CHECKED	APPROVED	TITLE		DATE
Lipf			LABEL		05/01/17
			UNITS	mm	DRAWING No.
			SCALE	2:1	N0Y02-0063
ENG ELECTRICS CO., LTD.			DRAWING NAME		REVISION
			1007		01

Att.2

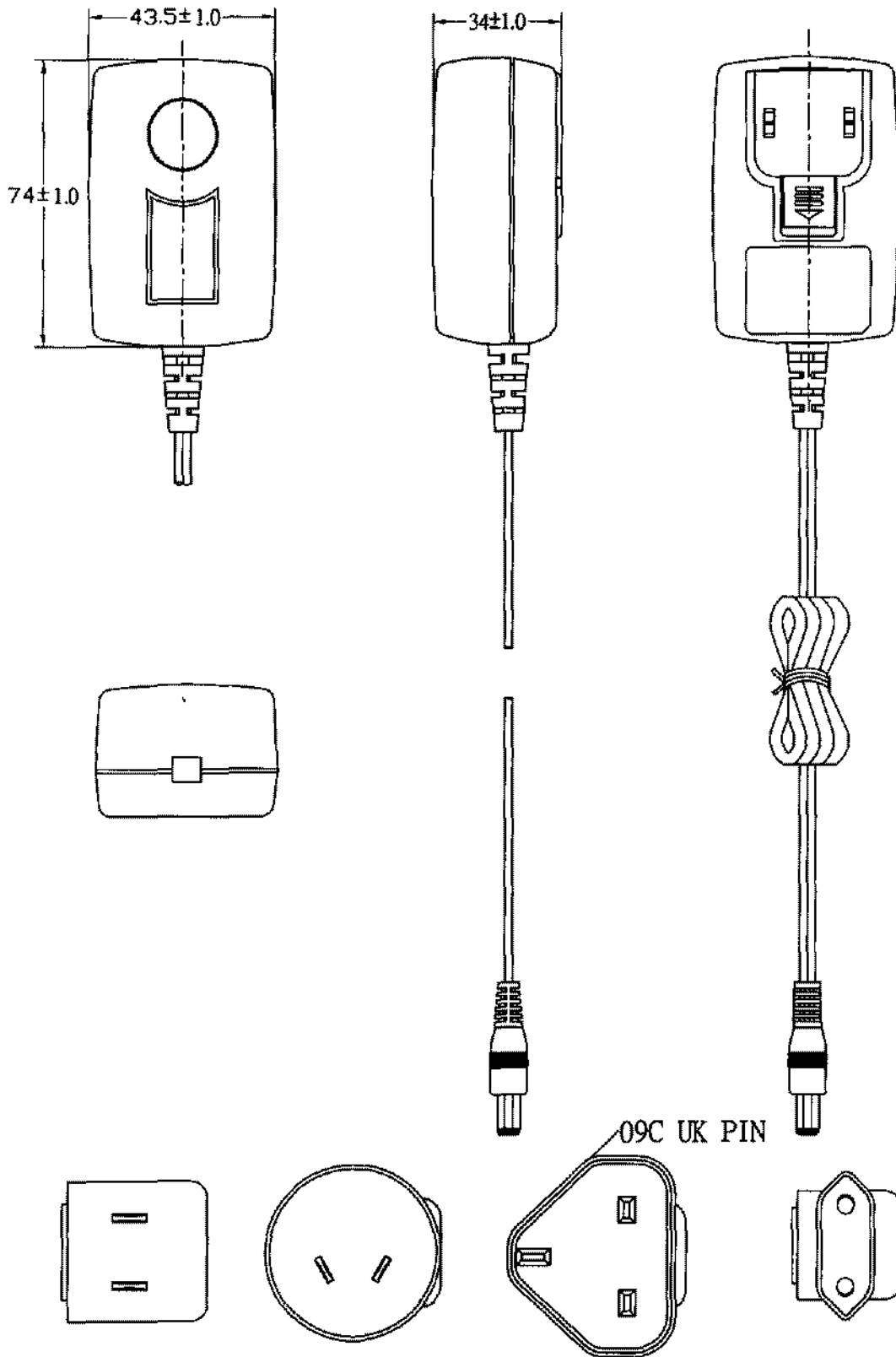

TOLERANCE				

DESIGNED	CHECKED	APPROVED		TITLE	DATE
<i>Lipf</i>				UNITS	OUTDRAWING
ENG ELECTRIC CO; LTD			mm	DRAWING No.	REVISION
			SCALE	@3A-181WP18-027	
				DRAWING NAME	
				100721	

Att.3

CARTON SIZE: 478X421X200mm

外箱尺寸 478X421X200mm

Q'TY: 60pcs(20x3)

数量 60pcs(20x3)

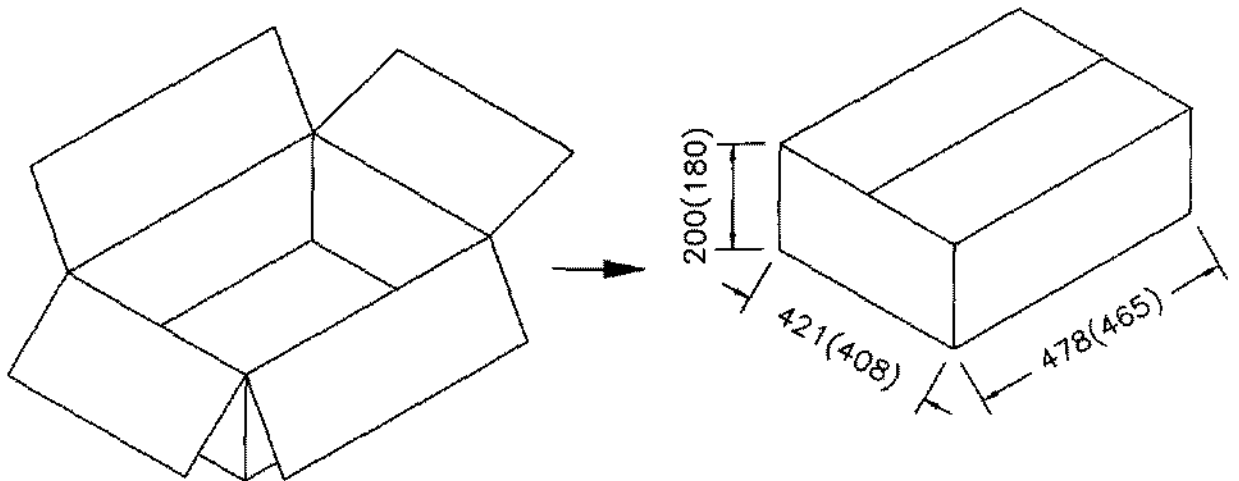
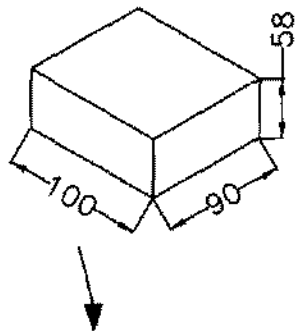

The tolerance of the internal dimensions of the carton is +7/-0
 纸箱内度尺寸公差为+7/-0

TOLERANCE				

DESIGNED	CHECKED	APPROVED			TITLE	DATE
<i>Lip</i>			UNITS	mm	PACKAGE	
			SCALE		DRAWING No.	05/01/17
ENG ELECTRIC CO; LTD					DRAWING NAME	REVISION
					13-2030-H-50	01

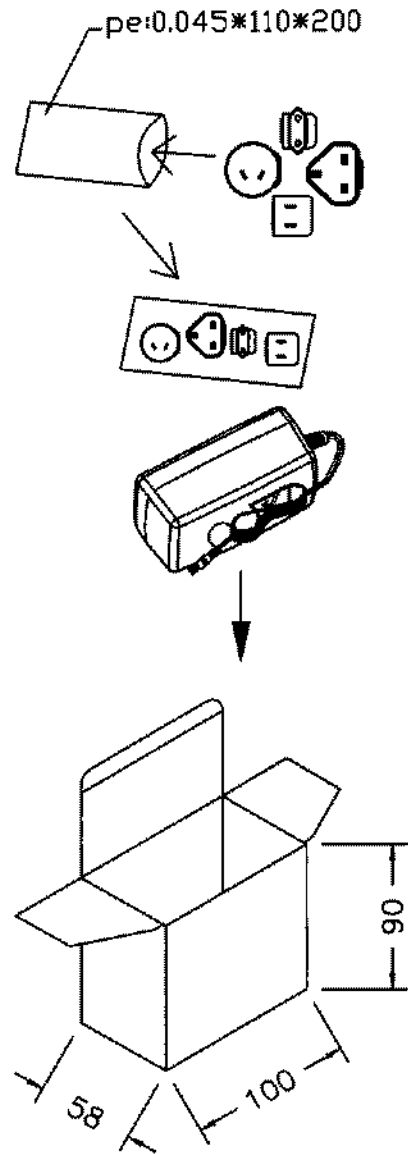

White Box: NO.13

小礼盒号码 13#

The tolerance of the external dimensions of the white box is ± 1
 小礼盒外度尺寸公差为 ± 1

TOLERANCE				

DESIGNED	CHECKED	APPROVED		TITLE	DATE
Lipf				PACKAGE FLOW CHART	05/01/17
			UNITS	DRAWING No.	
			SCALE	@3A-181WP18-027	
ENG ELECTRIC CO; LTD				DRAWING NAME	REVISION
				13#	01

Att.4

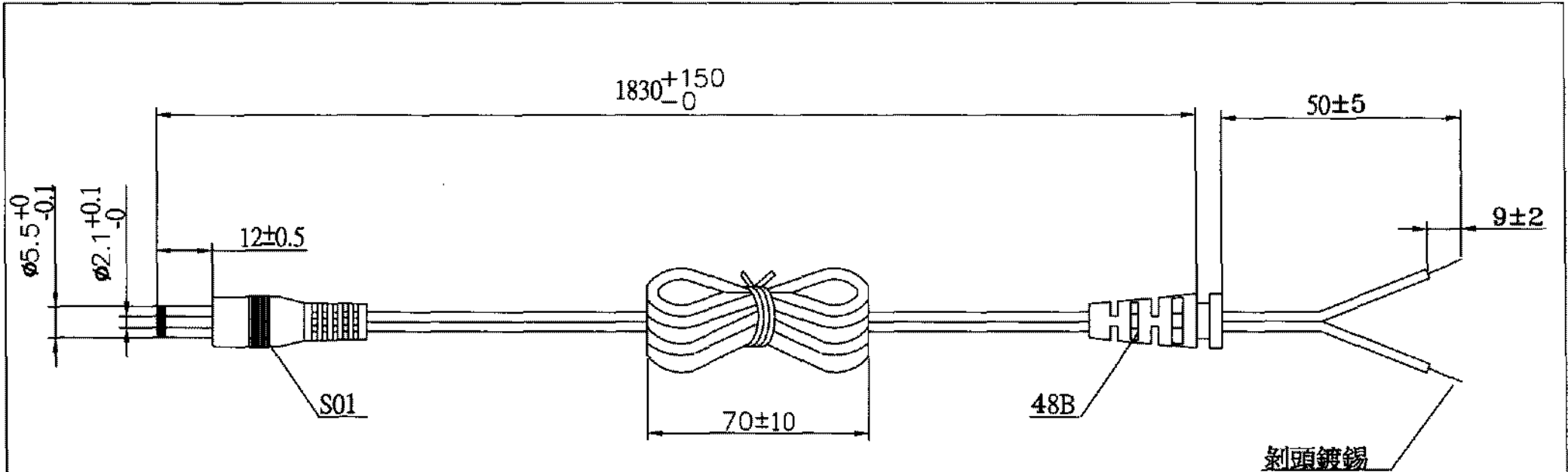

#20AWG X2C UL2468

有字接外 無字接內

線材OD: Ø1.9*3.8



TOLERANCE

制作參數要求

搖擺測試 VIBRATION TEST	a. ±60°
	b. 吊重200g WEIGHT 200g
	c. 40回/分 40 ROUND/MINUTE
	d. 1000次/最少 OVER 1000 COUNT MIN

DESIGNED	CHECKED	APPROVED		TITLE	DC CORD	DATE
<i>Lip</i>				UNITS	mm	DRAWING No.
ENG ELECTRIC CO; LTD			SCALE	DRAWING NAME	@3A-181WP18-027	REVISION
				31-48BS01-03B-00	01	