

PART NO.	ENG. NO.
02-09-1142	1433-A(P90 I)
02-09-1144	1433-A(P90 II)
02-09-5146	1433-A(P550)
02-09-5147	1433-A(P550)IL
02-09-5165	1433-A(P563)

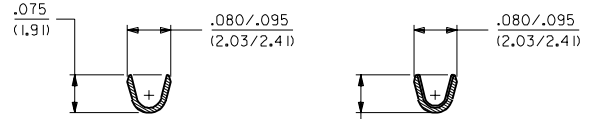
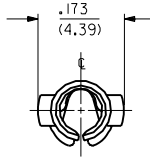

SECT. "A-A" SECT. "B-B"

**LEGEND**

1433-A(\*\*\*\*)\*  
 \* FORM  
 BLANK=CHAIN  
 L=LOOSE  
 P=PREPLATE  
 BLANK=POSTPLATE  
 FINISH CODE

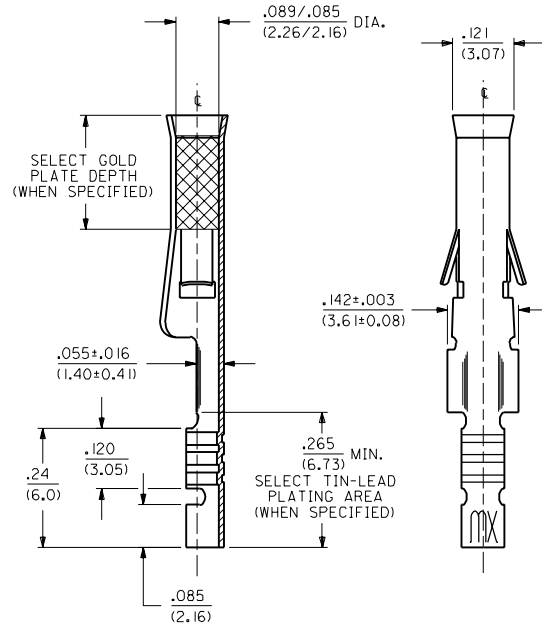
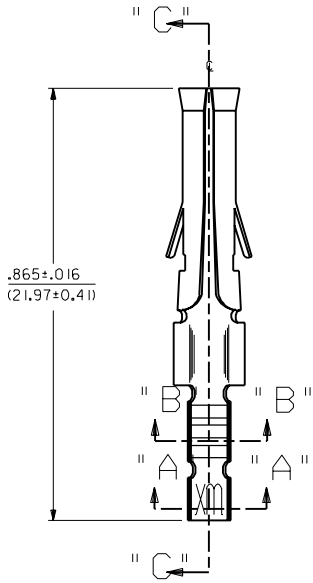

SECT. "C-C"

- NOTES:
1. TERMINAL FOR USE WITH .093/(2.36) SERIES HOUSINGS AND WILL ACCEPT 24 THRU 30 AWG WIRE.
  2. INSERTION FORCE: 3.5 LBS. MAX. WHEN TERMINAL IS INSERTED INTO AN .093 SERIES HOUSING.
  3. CONTACT RETENTION: 20 LBS. MIN.
  4. THIS PART CONFORMS TO PROD. SPEC. 02-09.

- FINISH CODES:
- 901 HOT TIN DIP .000020/(0.00051) MIN.
  - 903 HOT TIN-LEAD DIP .000050/(0.00127) MIN.
  - 550 SELECT GOLD PLATE .000015/(0.00038) MIN. IN CONTACT AREA, OVER .000030/(0.00076) MIN. NICKEL OVERALL WITH .000010/(0.00025) MAX. GOLD FLASH OVERALL.
  - 563 SELECT GOLD PLATE .000030/(0.00076) MIN. IN CONTACT AREA, SELECT TIN-LEAD PLATING .000100/(0.00254) MIN. IN CRIMP AREA OVER .000050/(0.00127) NICKEL OVERALL.

MATERIAL:  
 CARTRIDGE BRASS, ALLOY #C26000,  
 .010/(0.25) THICK, SPRING TEMPER

AA	REVISE PER ECR US 0799	ECR	2/13/95	RW
Z	FINAL RELEASE ECR 11/04/54	ECR	2/20/91	RW

MFG. SH. REV. LTR. REVISIONS

DIMENSIONS SHOWN METRIC (INCH)		▽=0	▽=0	REVISE ONLY ON CAD SYSTEM	
UNLESS OTHERWISE SPECIFIED TOLERANCES ANGULAR ± 1/2°		TITLE			
3 PLACE ± .010		CRIMP TERMINAL, FEMALE			
2 PLACE ± .014 ± 0.25		.093/(2.36) DIA. FOR			
1 PLACE --- ± 0.36		24 THRU 30 AWG WIRE			
DRAFT WHERE APPLICABLE MUST REMAIN WITHIN DIMENSIONS		MOLEX INCORPORATED		SHEET NO. 1	DATE 2/20/91
DRWG. BY CWF		CHKD. BY RW		PART NO. SD-1433-*	
APP'D. BY GWF		SCALE 6 : 1		FILE NAME S1433X1.DWG	
THIS DRAWING CONTAINS INFORMATION THAT IS PROPRIETARY TO MOLEX INC. AND SHOULD NOT BE USED WITHOUT WRITTEN PERMISSION.					

1433